



Proceedings of the  
**4<sup>th</sup> Virtual International Conference**  
**Path to a Knowledge Society -**  
**Managing Risks and Innovation**

---

Editors:

Stanković, M. and Nikolić, V.

Publishers:

Complex System Research Center, Niš, Serbia

Mathematical Institute of the Serbian Academy  
of Sciences and Arts, Belgrade, Serbia

December 08-09, 2022



Editors  
Stanković, M.  
Nikolić, V.

# **PaKSoM 2022**

4th Virtual International Conference  
Path to a Knowledge Society-Managing Risks and  
Innovation  
Proceedings

Publishers  
Complex System Research Centre, Niš, Serbia  
Mathematical Institute of the Serbian Academy of Sciences and Arts

Serbia, Niš, December 08-09, 2022



Proceedings of  
**4<sup>th</sup> Virtual International Conference**  
**Path to a Knowledge Society-Managing Risks and Innovation**

Serbia, Niš, December 08-09, 2022

Editors:

Prof. Dr. Miomir Stanković and Prof. Dr. Vesna Nikolić

Technical Editor:

Dr. Lazar Z. Velimirović

Published by:

Complex System Research Centre, Niš, Serbia, and  
Mathematical Institute of the Serbian Academy of Sciences and Arts

Printed by:

Copy House, Niš, Serbia

Number of copies printed: 100

The publishing year: 2023

Printing of this edition has been financially supported by  
Serbian Ministry of Education, Science and Technological Development

ISBN 978-86-82602-00-2

CIP - Katalogizacija u publikaciji  
Narodna biblioteka Srbije, Beograd

005.94(082)(0.034.2)

005.591.6(082)(0.034.2)

007:004(082)(0.034.2)

**VIRTUAL international conference Path to a Knowledge Society-Managing Risks and Innovation (4 ; 2022 ; Niš)**

Proceedings [Elektronski izvor] / 4th Virtual international conference Path to a Knowledge Society-Managing Risks and Innovation PaKSoM 2022, Serbia, Niš, December 08-09, 2022; [organizer] Mathematical Institute of the Serbian academy of sciences and arts; [co-organizers Research and Development Center "IRC ALFATEC" [and] Complex System Research Centre]; editors Stanković, M. [Miomir], Nikolić, V. [Vesna]. - Niš : Complex System Research Centre: Mathematical Institute of SASA, 2023 (Niš: Copy house). - 1 elektronski optički disk (DVD); 12 cm

Sistemski zahtevi: Nisu navedeni. - Nasl. sa naslovne strane dokumenta. - Tiraž 100. - Bibliografija uz svaki rad.

ISBN 978-86-82602-00-2 (CSRC)

a) Знање -- Менаџмент -- Зборници б) Предузећа -- Пословање -- Иновације -- Зборници  
в) Информациона технологија -- Зборници

COBISS.SR-ID 111014665

# **PaKSoM 2022**

## **4<sup>th</sup> Virtual International Conference Path to a Knowledge Society-Managing Risks and Innovation**

**Organizer:**

Mathematical Institute of the Serbian Academy of Sciences and Arts

**Co-organizers:**

- Research and Development Center “IRC ALFATEC”
- Complex System Research Centre

**Supported by:**

Serbian Ministry of Education, Science and Technological Development







## **Program Committee**

### **Chair:**

**Prof. Dr. Miomir Stanković**

Mathematical Institute of the Serbian Academy of Sciences and Arts, Serbia

### **Members:**

**Prof. Dr. Zoran Stajić**

Faculty of Electronic Engineering, Serbia

**Prof. Dr. Vesna Nikolić**

Faculty of Occupational Safety, Serbia

**Dr. Lazar Z. Velimirović**

Mathematical Institute of the Serbian Academy of Sciences and Arts, Serbia

**Prof. Dr. Bojan Srđević**

Faculty of Agriculture, Serbia

**Prof. Dr. Ilija Hristoski**

Faculty of Economics Prilep, Republic of North Macedonia

**Prof. Dr. Constantin Ilie**

Universitatea OVIDIUS din Constanta, Romania

**Prof. Dr. Aleksandar Janjić**

Faculty of Electronic Engineering, Serbia

**Prof. Dr. Radomir Stanković**

Mathematical Institute of the Serbian Academy of Sciences and Arts, Serbia

**Prof. Dr. Constantinos Challoumis**

National and Kapodistrian University of Athens, Greece

**Prof. Dr. Gabrijela Popović**

Faculty of Applied Management, Economics and Finance, Serbia

**Prof. Dr. Maja Đurović**

Faculty of Mechanical Engineering, Serbia

**Prof. Dr. Francisco Leandro**

City University of Macau, Macau SAR, China

**Prof. Dr. Marko Serafimov**

Faculty of Mechanical Engineering, North Macedonia

**Prof. Dr. Detelin Markov**

Faculty of Power Engineering and Power Machines, Bulgaria

**Prof. Dr. Zoltán Szira**

Faculty of Economics and Social Sciences, Szent István University, Hungary

**Prof. Dr. Milena Stanković**

Faculty of Electronic Engineering, Serbia

**Prof. Dr. Oleg Sergeevich Sukharev**

Institute of Economics of the Russian Academy of Sciences, Moscow, Russia

**Dr. Ivana Marinović Matović**

Addiko Bank AD, Serbia

**Prof. Dr. Snajay Kumar Mangla**

Maharaja Agrasen Institute of Management Studies, India

**Prof. Dr. Mustafa Yasan**

Sakarya University Faculty of Law, Turkey

**Prof. Dr. Sraboni Dutta**

Birla Institute of Technology, Mesra, Ranchi, India

## **Organizing Committee**

### **Chair:**

**Dr. Lazar Z. Velimirović**

Mathematical Institute of the Serbian Academy of Sciences and Arts, Serbia

### **Members:**

**Prof. Dr. Zoran Stajić**

Faculty of Electronic Engineering, Serbia

**Dr. Petar Vranić**

Mathematical Institute of the Serbian Academy of Science and Arts, Serbia

**Dr. Dušan Tatić**

Mathematical Institute of the Serbian Academy of Sciences and Arts, Serbia

**Dr. Radmila Janković Babić**

Mathematical Institute of the Serbian Academy of Science and Arts, Serbia

**M.Sc. Jelena Velimirović**

Mathematical Institute of the Serbian Academy of Sciences and Arts, Serbia

**M.Sc. Ivana Veličkowska**

Mathematical Institute of the Serbian Academy of Sciences and Arts, Serbia

**M.Sc. Ljubiša Stajić**

Research and Development Center “IRC ALFATEC”, Serbia

**M.Sc. Biserka Mijucić**

Research and Development Center “IRC ALFATEC”, Serbia

**M.Sc. Danijela Protic**

Serbian Armed Force, Serbia



## Table of Contents

<b>Green Bonds: Novel Opportunity for the Serbian Capital Market? .....</b>	<b>3</b>
Vladimir Mirković, Marina Iliev Matić	
<b>Digital Transformation of Public Administration and Services in Hungary .....</b>	<b>11</b>
Edit Soós	
<b>Contemporary Tendencies and Barriers in Knowledge Management in Tourism .....</b>	<b>19</b>
Borislav Kolarić, Goran Stojićević, Jelena Ignjatović, Aleksandra Đorđević	
<b>The Foundations for the Future Innovation Ecosystem - A Digital Twins Framework Approach .....</b>	<b>27</b>
Branko Perišić, Ana Perišić	
<b>The Managerial Prerogative of Employer and Internal Labour Mobility: Where are the Boundaries? .....</b>	<b>35</b>
Tijana Kovačević	
<b>Risk Management during Storing of Hazardous Substances .....</b>	<b>43</b>
Goran Tepić, Nina Ivanović, Mihaela Tarakčija	
<b>The Simulation of Stable Systems for Fire Extinguishing as Advance Step in Fire Protection .....</b>	<b>51</b>
Radoje B. Jevtić, Ivana D. Janković, Momčilo B. Randjelović	
<b>Blockchain as a Methodology in the Implementation of Sustainable Tourism ..</b>	<b>57</b>
Vladimir Živanović, Marko Živanović	
<b>Transportation Problem with Additional Bounded Capacity .....</b>	<b>65</b>
Bratislav Lukić, Goran Petrović	
<b>Using the MCDM Approach to Evaluate Smart and Sustainable Cities .....</b>	<b>73</b>
Ibrahim Badi, Željko Stević, Muhammad Lawan Jibril	
<b>Multimedia Systems in Education .....</b>	<b>79</b>
Marko Marković, Neda Ilić, Ana Kresović Kolundžić, Maja Đurović-Petrović, Jasmina Lozanović	
<b>Mitigating COVID-19 Crisis Effects in SMEs by Knowledge Management .....</b>	<b>85</b>
Ivana Marinović Matović, Andela Lazarević	

<b>The Significance of Sustainability and the Management of the Green Economy using Modern Technology</b> .....	<b>93</b>
Biljana Ilić, Zorica Djurić	
<b>The Importance of Innovation and Creativity of Employees in Modern Organizations</b> .....	<b>101</b>
Dragana Kovač, Edit Terek Stojanović, Mihalj Bakator, Mila Kavalić, Verica Gluvakov, Maja Gaborov	
<b>Education for Perception and Interpretation of Reality in the Digital Environment</b> .....	<b>107</b>
Branko Marković	
<b>Open Innovation Paradigm</b> .....	<b>113</b>
Vanja Vukojević, Milenko Tanović	
<b>The Role of Innovation Capital in Developing Youth Entrepreneurship</b> .....	<b>117</b>
Dragan Čočkaló, Mihalj Bakator, Sanja Stanisavljev, Edit Terek Stojanović, Miloš Vorkapić	
<b>Development through Social Entrepreneurship: Perspectives and Evidence from Croatia</b> .....	<b>123</b>
Tihana Sudarić, Ivana Hrg Matušin, Jadranka Deže	
<b>The Impact of Blockchain Technology on the Accounting Information Systems</b> .....	<b>129</b>
Tanja Janačković, Marko Janačković	
<b>Family Business Management in the Knowledge Era</b> .....	<b>137</b>
Sandra Stojadinović Jovanović, Bojan Krstić, Violeta Domanović	
<b>Digital Transformation in the Field of Education using an Innovative Solution</b> .....	<b>143</b>
Aleksandra Tašković, Angela Fajsi, Slobodan Morača	
<b>Innovation Management in the Concept of Smart Cities</b> .....	<b>151</b>
Bojan Krstić, Milica Jovanović Vujatović, Marija Jovanović	
<b>Role of Artificial Intelligence for Promoting Financial Inclusion</b> .....	<b>159</b>
Reena Agrawal	

<b>Modeling the Time-based Maintenance Strategies with Petri Nets</b> .....	<b>165</b>
Ilija Hristoski, Tome Dimovski	
<b>Basel 3.1 – New Regulatory Framework for Banks</b> .....	<b>173</b>
Vesna Martin	
<b>Research and Development of Human Resource Management in Serbian Organizations</b> .....	<b>181</b>
Tijana Krušković, Biljana Ilić, Slavica Anđelić	
<b>Measurement of Innovation in Economic Growth Research</b> .....	<b>187</b>
Nataša Stanojević, Slobodan Kotlica, Katarina Zakić	
<b>The Way to Understand the Use of Technology for the Purpose of Developing Gastronomic Tourism</b> .....	<b>195</b>
Drago Cvijanović, Tamara Gajić, Dragan Vukolić	
<b>Analysis of the Influence of Types of Multimedia Content in Posts on Social Networks on the Success of Posting</b> .....	<b>203</b>
Đorđe Petrović, Ivan Pantelić, Dejan Beljić	
<b>Education and Knowledge about Sustainable Development Goals</b> .....	<b>209</b>
Milica Stanković, Jovana Džoljić, Tiana Anđelković, Suzana Stojković	
<b>Naïve Bayes Classifier Model for Predicting Admission in Master’s Program Based on Academic Grades</b> .....	<b>217</b>
Kavita Gupta	
<b>Knowledge Management Strategy, Resources and Competences</b> .....	<b>223</b>
Milošan Rogan	
<b>Funding Models in the European Startup Ecosystem</b> .....	<b>229</b>
Aleksandar Vekić, Jelena Borocki, Ana Ivanić, Galina Žižakov	
<b>Intellectual Capital and Emergencies</b> .....	<b>237</b>
Jelena Malenović-Nikolić, Uglješa Jovanović	
<b>Performance Quality: A Measure of Organizational Complexity</b> .....	<b>245</b>
Dragoljub Šarović	
<b>Digital Transformation of the Teaching Process using Mobile Devices and Dedicated Software</b> .....	<b>249</b>
Momčilo B. Randelović, Radoje B. Jevtić, Ivana D. Janković	



<b>The Importance of the Evaluation of Investment Projects in Local Government Units .....</b>	<b>257</b>
Dragan Dokić, Vesna Gantner	
<b>Bankruptcy Proceeding as a Result of Fraud: Characteristics and Consequences .....</b>	<b>265</b>
Zorica Jović	
<b>Commercializing University Knowledge in Serbia – An Empirical Evidence ..</b>	<b>273</b>
Viktorija Petrov, Zoran Drašković, Đorđe Čelić, Zorica Uzelac	
<b>Understanding Employee Innovative Behavior in Serbia: A Comparison with EU Country .....</b>	<b>281</b>
Bojana Milić, Milan Lečić, Jelena Spajić, Dunja Bošković, Danijela Lalić	
<b>Problems of Quantitative Measurement Technological Level of the Economy .....</b>	<b>287</b>
Oleg Sukharev	
<b>Competencies for the Knowledge Economy and Reducing Unemployment .....</b>	<b>291</b>
Milica Stanković, Tiana Anđelković	
<b>The Legal Interpretation as a Decision-Making Algorithm .....</b>	<b>299</b>
Živorad Rašević, Marko Čitić	
<b>Remote Working in the Digital Age: Benefits and Potential Negative Effects ..</b>	<b>307</b>
Jelena Lukić Nikolić	
<b>The Role of Social Media in Coups d'État .....</b>	<b>313</b>
Tanja Milošević, Nina Milošević	
<b>Nexus between Intellectual Capital and Organizational Learning Capability .....</b>	<b>321</b>
Matea Zlatković Radaković	
<b>Choice of Methodology for Management IoT Project .....</b>	<b>329</b>
Maja Gaborov, Jelena Grujić, Dragana Kovač, Mila Kavalić, Stefan Ugrinov	
<b>Consumer Behavior and its Influences in 2022 .....</b>	<b>337</b>
Lenka Veselovská	

<b>Investigating Digital Divide in European Rural Areas as a Barrier to Knowledge Sharing .....</b>	<b>343</b>
Anđelka Stojanović, Aleksandra Radić, Sanela Arsić, Isidora Milošević	
<b>Quis custodiet ipsos custodes: Ethical Dilemmas of the KM Governed by AI .....</b>	<b>351</b>
Željko Bjelajac, Aleksandar M. Filipović, Lazar Stošić	
<b>Industrial Property Rights as Types of Capital in Commercial Companies in Turkish Law .....</b>	<b>359</b>
Mustafa Yasan	
<b>Advantages and Limitations of the Implementation of Intelligent Inventory Management Systems in the Supply Chain .....</b>	<b>365</b>
Nebojša Zorić, Violeeta Vrhovac, Stevan Milisavljević, Dejan Ilić, Stana Vasić	
<b>Crises and Innovations in Tourism - Development of Creative Tourism .....</b>	<b>373</b>
Snežana Štetić, Igor Trišić	
<b>Web Scraping Analysis: Gender Differences in Local Online Media Mentions .....</b>	<b>381</b>
Bojan Baškot, Maja Barišić	
<b>Improving Digital Competences of Persons with Disabilities as a Precondition for an Inclusive Digital Economy: Evidence from Serbia .....</b>	<b>389</b>
Milena Lazić, Valentina Vukmirović	
<b>Comparative Analysis of Human Development at the Global Level .....</b>	<b>395</b>
Suzana Stojković, Milica Stanković, Tiana Anđelković	
<b>School Culture as a Predictor of School Identity .....</b>	<b>403</b>
Dinko Jukić	
<b>Data Protection in Innovation under the European Union Legislation .....</b>	<b>411</b>
Iris Bjelica Vlajić	
<b>Metaverse and its Impact in Healthcare .....</b>	<b>419</b>
Sayani Ghatak, Sayan Chakraborty, Radha Debal Goswami, Hrithik Paul	
<b>The Influence of Mobile Phones on Children and Youth - General Overview .....</b>	<b>427</b>
Nenad Perić, Olja Arsenijević	

<b>Knowledge Management in the Hotel Industry as a Relevant Contribution to the Development of the Tourism Sector</b> .....	<b>433</b>
Borislav Kolarić, Jelena Ignjatović, Goran Stojićević, Aleksandra Đorđević	
<b>Legal Issues in Managing and Sharing Research Data</b> .....	<b>441</b>
Jelena Banović, Aleksandra Bradić-Martinović	
<b>Simulation of Evacuation of Immobile Persons as a Modern Evacuation Problem</b> .....	<b>449</b>
Radoje B. Jevtić, Ivana D. Janković, Momčilo B. Randjelović	
<b>A Multiple-Criteria Approach to RFID Solution Provider Selection</b> .....	<b>457</b>
Gabrijela Popović, Goran Milovanović, Đorđe Pucar	
<b>The Moderating Role of Employee Commitment and its Impact on Employee Involvement and Organizational Productivity</b> .....	<b>465</b>
Soumi Majumder	
<b>Importance of Reverse Logistics on Green Supply Chain Performance: An Empirical Study</b> .....	<b>471</b>
Saniye Yıldırım Özmütlu, Korhan Arun	
<b>Nature Prefers Sustainable Structures: Implications for Large-Scale Political Self-Organization</b> .....	<b>477</b>
Jacob C.W. Billings	
<b>Mediating Role of Knowledge Management Process in Turning Intellectual Capital and Social Capital into Innovation Capability and Sustainable Performance of SMEs</b> .....	<b>481</b>
Anh Tuan Pham, Quoc Trung Pham	
<b>How Did the Slovak Labour Market Change during the Coronavirus Crisis?</b> .....	<b>489</b>
Lucia Bartková	
<b>History of Statistical Thinking: From Uncertainty to Uncertain Knowledge</b> ..	<b>497</b>
Jan Kalina, Lubomír Soukup	
<b>Impact Factor of the Rest Rewarding Taxes</b> .....	<b>505</b>
Constantinos Challoumis	

<b>Innovative Management based on the Application of Internal Audit in the Public Sector of the Republic of Serbia .....</b>	<b>513</b>
Jelena Vitomir, Sonja Tomas-Miskin, Goran Vitomir, Slobodan Popović	
<b>Features of Preschoolers' Use of Digital Media: New Socio-Cultural Context .....</b>	<b>519</b>
Rubtsova Olga, Klopotova Ekaterina, Smirnova Svetlana, Sorokova Marina	
<b>Training Pre-service Teachers for using Educational Software in Order to Improve the Quality of the Mathematics Teaching in Primary Education .....</b>	<b>521</b>
Radoslav Božić, Ivica Nikolić, Violeta Petković	
<b>Organizations of the Planetary Civilization: Change between the Organization of 2022 and 2092 .....</b>	<b>523</b>
Sergey Ivanov	
<b>The Human Development Index as a Function of the Measure of Human Development in Serbia with Reference to the Countries of the Region .....</b>	<b>525</b>
Mirjana Štaka	
<b>The Elaboration of Computer Game System for the Measurement of Higher-Order Cognitive Skills by Middle-School Students .....</b>	<b>527</b>
Evgeniya Gavrilova, Elena Shepeleva, Yulia Tokarchuk	
<b>Profitability of Pakistan's Banking Sector and COVID-19 .....</b>	<b>529</b>
Syed Ahsan Ali Gardazi, Shumaila Zeb	
<b>Impact of Financial Technology on Financial Inclusion and Financial Performance: Empirical Evidence from Financial Sector of Pakistan .....</b>	<b>531</b>
Sehar Saleem, Shumaila Zeb	
<b>Teens' Communication via Social Media: Risks vs Opportunities .....</b>	<b>533</b>
Tatiana Poskakalova, Margarita Khusnutdinova, Olga Salomatova	
<b>Education in Antimicrobial Stewardship: Awareness of Antibiotics in Drinking Water .....</b>	<b>535</b>
Nikola Puvača, Svetlana Ignjatijević, Jelena Vapa Tankosić, Radivoj Prodanović	



# Green Bonds: Novel Opportunity for the Serbian Capital Market?

Vladimir Mirković<sup>1</sup>, Marina Iliev Matić<sup>2</sup>

<sup>1,2</sup>Economists Association of Belgrade, Belgrade, Serbia

<sup>1</sup>vladamirkovic@orion.rs, <sup>2</sup>marina.matic25@gmail.com

**Abstract**—Indisputable role of capital markets in global economic and financial system and their significant impact on a country's overall level of development, especially could be highlighted in those countries which experienced transition period toward an open market economy. Among those countries is the Republic of Serbia, which made an extraordinary effort in establishing an efficient and effective capital market, but reached results could be assessed as quite below expectations. Despite generally unfavorable evaluation of Serbian capital markets, the segment of the government bond market functions relatively comparatively. This paper presents an overview of the current situation in the Serbian bond supported by relevant figures, which comprehensively describe achieved level of development. Furthermore, in the context of increasing importance of ESG investing on a global level, some countries (and the Republic of Serbia among them) participated in the issuance of green bonds, as a type of climate-related financial instruments. This type of ESG bond could be assessed as a novel opportunity for revitalization of the Serbian capital market, upgrading both sides, supply and demand. Paper is analyzing potential impact of green bonds on prospective financial market development. Additionally, authors emphasized constraints related to the current level of development in the bond market segment and past experiences with the inclusion of certain bonds categories in the market, such as corporate bonds and covered bonds.

**Keywords** – green bonds, capital markets, ESG, circular economy

## I. INTRODUCTION

Regulation and supervision of the Serbian capital market is in the jurisdiction of Republic of Serbia Securities Commission (hereinafter:

SC). In the accession process toward EU, SC has a very important function through adoption of regulatory rules which are already well known and established in EU countries. The main purpose of adopted regulatory framework is promotion of transparency, as well as protection of shareholders' rights and investors' interest. All active participants in the Serbian capital market should possess valid license, approved by the SC.

At the end of 2021, new Law on Capital Market was adopted in Serbia to reflect the major priorities which are defined by Strategy for Development of the Capital Market for the period 2021-2026. Adoption of new Law on Capital Market represents important step in the process of further harmonization with legal and institutional framework valid within EU country members. The former Law on Capital Market, introduced in 2011, was partially aligned with EU framework, whilst this new legislation which entered into force on 5 January 2022 is more detailed and tailored to EU framework.

Additionally, it should be noted that implementation of the Law will start with delay of one year, i.e., 6 January 2023. Market participants, which operate due to license approved by SC, are obliged to harmonize, and align operations within proscribed deadline counting from the date of their entry into the force. In the meantime, on 16 July 2022 new Law on the Capital Market bylaws with set of 20 rulebooks came into force. The bylaws were published in the Official Gazette of RS No 77, on 8 July 2022 [1].

The "golden age" for domestic capital market was marked after the period of mass

privatization at the beginning of XXI century which is simultaneously the period of economy transition toward open economy principles. In that period, accelerated mass privatization and a positive global economic situation enabled a great expansion of the capital market. But it does not mean that the capital market was placed on neither a sound basis nor that capital market development in the Republic of Serbia was in the line with similar markets in regulated, open economies. The excess of capital available at that time covered up all anomalies of non-matured, young market, which were completely exposed in the later years of the global financial crisis.

Starting from the point that the consensus of economic policy makers is necessary for creation of efficient capital market, it was obvious that above mentioned consensus is much more difficult to establish in transition economies (such as Serbia) that are moving from non-market to open economies. The absence of politicians' will is the most common explanation for the Serbian capital market poor development, because in the vicious circle of dominant political and economic elites there was no place for some kind of equality, in which clear and predictable rules would be established.

Despite generally unfavorable evaluation of Serbian capital markets, the segment of the government bond market functions relatively comparatively [2]. This paper briefly described the major events in the Serbian capital market emphasizing the bond market and its infrastructure.

## II. OVERVIEW OF THE BOND MARKET

Debt financial instruments in the form of so-called "old savings bonds" were the first high-quality financial instruments listed on Belgrade Stock Exchange (hereinafter: BSE). Those bonds appeared when Serbian government recognized the debt of state-owned banks regarding savings in foreign currency and for that purpose government issued bonds with maturity dates at the end of year marking May from 2002 till 2016. Converted old saving bonds in the period August 2002 – November 2022 are shown in Table I.

The face value of issued bonds was EUR 4.2 billion and there was brought some measures to make trading with this type of debt

TABLE I. VOLUME OF CONVERTED SAVINGS BONDS [3].

Bonds RS – Series Ticker	ISIN	Volume of conversion (EUR)
ARS2002	RSMFRSD60544	111,991,622
ARS2003	RSMFRSD38805	187,026,202
ARS2004	RSMFRSD62078	203,273,235
ARS2005	RSMFRSD64033	236,160,910
ARS2006	RSMFRSD40710	223,854,487
ARS2007	RSMFRSD60130	219,560,225
ARS2008	RSMFRSD60916	221,111,483
ARS2009	RSMFRSD31842	227,400,888
ARS2010	RSMFRSD14186	237,551,554
ARS2011	RSMFRSD18757	251,346,140
ARS2012	RSMFRSD93024	267,788,152
ARS2013	RSMFRSD68018	287,956,819
ARS2014	RSMFRSD73810	311,577,665
ARS2015	RSMFRSD79726	335,047,901
ARS2016	RSMFRSD70279	350,252,954
<b>TOTAL:</b>		<b>3,671,900,237</b>

instrument more attractive, e.g., exclusion from tax burden [4].

Old savings bonds played a great role in Serbia as an instrument that brings back confidence into the Serbian financial system, especially the most prominent part, the banking sector.

As global financial crisis emerged and the spillover effect was obvious even in Serbia, the government of the Republic of Serbia issued government Treasury bills and bonds in 2009. This issuance of government bonds was part of a wider strategy intended for debt market development, but it also was not successful. Concretely, issued bonds were not traded frequently and even when trading was realized those deals were not based on market principles, already through direct contract with in advance known counterparty. Furthermore, debt securities of municipalities and cities were not affirmed yet by expectations.

The most quality segment of the Serbian bond market makes government bonds. According to Serbian legislation, government debt securities are instruments denominated in domestic or foreign currency, where the issuer is government or competent ministry. Mentioned bonds are registered in electronic form in Central Securities Depository and Clearing House [5]. Financial stability of the issuer determines the rating of bonds which is also a crucial indicator of bond's riskiness.

With emerging of Covid-19 pandemic in 2020, National bank of Serbia (hereinafter: NBS) introduces several measures which could have the connotation of reform. As part of

measures to support liquidity in domestic currency (dinar), the NBS included dinar-denominated corporate bonds from the non-financial sector (with a maximum maturity of up to 10 years and a creditworthiness rating of D “Acceptable creditworthiness” and higher assigned by the Serbian Business Registry) to the list of securities that can be used in monetary operations, i.e., repo and other permanent transactions.

The maximum investment amounts in corporate bonds are defined by the NBS and SC regulations. Total amount of corporate bonds which the NBS can accept in monetary operations is RSD 55 billion, while the maximum exposure related to individual issuer is RSD 11 billion. The highest total nominal amount of an individual issue or tranche of corporate bonds that can be accepted in monetary operations is 70% of the total nominal value of the issue of individual issuer [6]. The key point in the development of corporate bond market is personified in attempt of the NBS inclusion as a buyer of these securities on the secondary market.

According to Table II, it is evident that the largest amounts of corporate bonds are concentrated in public companies or companies in which the state is the majority owner (e.g., Telekom Srbija with RSD 23.5 billion, JP Jugoimport SDPR RSD 15.3 billion with its related parties Complex Combat Systems and PMC - Inženjering RSD 5.405 billion and RSD 2.82 billion, respectively). By analyzing the structure of the issuers which mostly participate in the total issue of dinar corporate bonds, critical opinions, that strengthening and developing the capital market was not achieved, gain even more importance. The only side that benefits from this type of bond was state and para-state systems that obtained the necessary liquidity, which they certainly could not have achieved through regular means e.g., through the bank’s loan [7]. The former NBS governor Dejan Šoškic very convincingly proved that the issuance of illiquid corporate bonds “practically represents a completely non-transparent state subsidy to certain private or state-owned enterprises”, adding that it is “funding of enterprises through primary issuance based on discretionary decisions of the central bank” [8].

Types of corporate bond that bear slightly higher fixed returns than government bonds are

TABLE II. CORPORATE BONDS OVERVIEW [9]

Issuer	Nominal value (in 000 RSD)	Maturity Date
A&M Solution Team	2,860	01.09.2023
Mlekara Šabac	60,000	21.06.2024
Anador Konsalting	6,240	23.12.2022
Borbeni složeni sistemi	5,405,000	09.09.2027
Energoprojekt Holding	3,300,000	30.12.2025
Graditelj-Beograd	35,000	16.03.2023
JP Jugoimport SDPR	15,275,000	10.09.2025
Mediolanum Invest	235,200	20.09.2026
PMC - Inženjering	2,820,000	09.09.2025
RT Consulting	3,300	16.10.2023
Sagittarius Project System	2,860	26.05.2023
Telekom Srbija	23,500,000	25.09.2025

known as covered bonds. Their main characteristic is personified in twofold collateralization for investors. “Investor in covered bonds possesses collateral in the equity of issuer (i.e., financial institution or bank) or priority right over cash flow derived from loan that was a basis for issuance of covered bond (in the case of issuer bankruptcy)” [10].

Recognizing the importance of covered bonds and the opportunity to include them in the numerator of liquidity coverage ratio as a part of highly liquid assets, NBS defined the role of covered bonds and main preconditions for their inclusion in documents such as: “Decision on Capital Adequacy of Banks” (RS Official Gazette, No 103/2016, 103/2018, 88/2019, 67/2020, 98/2020, 137/2020, 59/2021 and 67/2022) and “Decision on Liquidity Risk Management by Banks” (RS Official Gazette, No 103/2016). In most countries, the area of covered bond is regulated by special acts (“lex specialis”) or by general legislative framework. Despite efforts of NBS and precise definition of provisions related to the covered bonds regulation (which are more than solid ground for primary issuance and active trading in the secondary market), results in practice could be assessed as unsatisfactory.

Poor development in the segment of covered bonds market is one more missed opportunity for improvement of the Serbian capital market. Neither good legislative basis nor general interest in a widening number of financial alternatives has influenced dramatically on the potential positive movements in the Serbian capital market.



Apart from the bond market, which is in detailed elaborated in this paper, it should be pointed on several facts about the equity market as an important part of the capital market in the Republic of Serbia. The equity market was developed parallel with the mass privatization program, one of the main characteristics of all transition countries in the process of adjustment to the open economy. Privatization was realized in four stages in a period between 1991 as the first stage and 2010 as the final stage.

After the mass privatization of companies, the equity market became more liquid and came into the sphere of interests of domestic mutual funds and foreign investors. Instead of affirmative development of the stock market, there was a grotesque situation: business is controlled by politicians and manipulated in the manner that avoids appearing in the stock market is acceptable behavior, even if citizens of the Republic of Serbia are massively represented in the ownership structure of those companies. Undoubtedly, authors of this paper have a long-lasting feeling that none of the interests' groups has any interest in developing the equity market and collecting capital through BSE.

It is a very devastating fact that the initial public offering (hereinafter: IPO) of Serbian private company Fintel Energija realized at the end of October 2018, was the first completed Serbia's IPO since 1940. In Fintel's IPO, more than 1.5 million shares were issued, which was the minimum threshold for a successful process. The company raised EUR 6.3 million for the development of business and expansion of network of wind parks in Serbia. Shares of Fintel Energija have been added to the Prime Listing section on BSE [11].

BSE suffers from several shortcomings such as: the small number of high-quality listed companies in the equity market, the lack of IPOs and the absence of liquidity. Until above mentioned isolated case of Fintel Energija IPO, Serbia has not recorded any IPOs for almost the whole century. The government has never used IPOs for mass privatization purposes, whilst private companies have not raised capital through IPOs either.

Those facts explain why the Serbian equity market is in a very difficult situation for a decade and a half. Together with the high number of delisting companies in recent years, BSE is suffering from the absence of attractive

investment alternatives. It is characterized by the absence of large scale institutional investors and existence of fewer financial instruments in comparison with developed markets, i.e., tighter options among several investment alternatives. Insufficient level of development in terms of financial instruments available in the Serbian capital market and unawareness of domestic investors regarding investment opportunities (as well as the absence of the politicians' will) together influenced on inadequate deployment of the capital market.

Transition period in Serbia lasts too long, so necessary changes were not realized in terms of adequate adjustment to the major principles of an open market economy. Missed opportunities and experiences from the past could give another impulse for development of the Serbian capital market. From the point of view of everyday life, the circular economy topic became one of the most interesting topics.

The importance and necessity of orientation on the circular economy are well understood and recognized by international financial institutions (e.g., EBRD, EIB, etc.) which place their investment projects in the green economy on target markets based on cooperation with local banks interested in this type of lending. Nowadays, all market participants should act in the favor of "green" behavior. As green behavior became the standard for our civilization, new sources of funding emerged and became important. Some of the novel funding sources could have a great impact on the prospective development of capital markets.

Currently, when the acronym ESG (consisting of words: Environmental, Social and Governance) is widely used and recognized as a mainstream holistic approach worldwide, understanding green bond securities and the importance of the green bond market is more than desirable. "ESG helps stakeholders to understand how an organization is managing risks and opportunities related to environmental, social, and governance criteria" [12]. The definition of ESG issues is dynamic due to the fact that society applies different classification criteria over time, resulting from new information (e.g., the impact of carbon dioxide emissions) or changing perceptions. Certainly, ESG concept is based on three pillars: environmental, social and governance with the prevailing orientation

on health and safety issues, pollution reduction, and corporate philanthropy.

The introduction of green bonds changed the outlook of bond markets worldwide, creating new opportunities for financial market participants as well as society as whole, and simultaneously contributing to healthier and cleaner environment. The central part of this paper is dedicated to the topic of green bonds.

### III. GREEN BONDS: NOVEL OPPORTUNITY

Green securities support the financing of activities and projects primarily aimed at environment protection. This is specifics and innovation inherent for green securities, making a crucial difference in comparison with traditional securities, considering that the issuer of green securities is obliged to collect funds that are used for financing of green projects or business activities. Collected funds could be directed to: energy efficiency (including construction of energy efficient buildings); sustainable waste management; sustainable agriculture and forestry; sustainable water management; preservation of biodiversity; clean transport and adaptation to climate changes [13].

In the absence of unique definition, in this paper is cited the World Bank quotation regarding green bonds. “A green bond is a debt security that is issued to raise capital specifically to support climate-related or environmental projects” [14]. It is characterized with the specific usage of the collected funds, for the purpose of financing projects which are aligned with environmental standards. Although green bonds are distinguished from regular bonds by their main purpose, when it comes to the analysis of the major features, green bonds have the same characteristics as any other type of bond, such as: maturity, coupon, price, and credit quality of the issuer. From the risk management point of view, green bonds are less riskier than regular bonds and shares as well as less dependent upon unpredictable macroeconomic events. It is generally accepted that green bonds are priced very close to regular bonds; meaning that investors are not willing to give up a return or pay extra for the green aspect of the bond and related reporting.

Among the first issuers of green bonds were multilateral development banks. For example, The European Investment Bank (EIB) issued a

€600 million Climate Awareness Bond in 2007 that focused on renewable energy and energy efficiency sectors. The main feature of these bonds is reflected in the linkage of returns with an equity index (instead of a fixed coupon) giving them the character of so-called “structured bonds”. At the end of 2020, EIB is a world leader in green bonds issuing over EUR 33.7 billion raised across 17 currencies, of which the EUR equivalent of 6.8 billion is reached in 2020 [15].

The International Bank for Reconstruction and Development (IBRD) issued its first green bond in 2008 in the amount of approximately US\$ 440 million for several reasons. The first reason is related to the support of climate-focused projects meeting demand from Scandinavian pension funds. Second, this is a part of World Bank's strategy to introduce innovation in climate finance and third, this help regarding raising awareness among investors and the financial community about climate change actions and their global consequences. As of the end of June 2015, the IBRD has issued US\$ 8.5 billion in over 100 green bond transactions in 18 currencies, supporting about 70 climate mitigation and adaptation projects around the developing world [16]. The process of green bonds issuing is very similar worldwide so in this paper is presented the World Bank process that encompasses four stages (Fig. 1).

The Republic of Serbia is among the countries in Europe which are heavily affected by the impact of climate change. In the spirit of successful tackle with potentially devastating effects, Serbia has joined the global efforts intended to movement toward a green economy. Initially, Green Bond Framework is

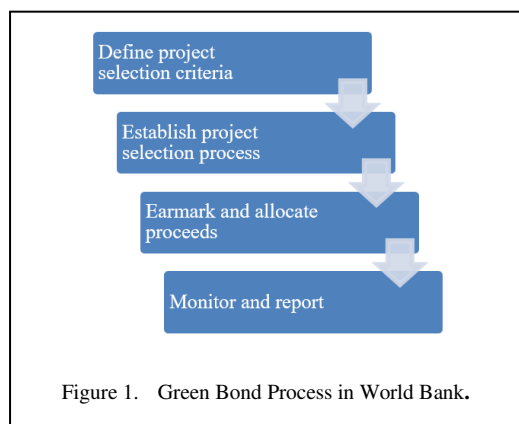

created to support environmental protection and raise funds from the international capital markets [17]. Through the green bonds agenda, the level of awareness regarding sustainable financing will increase, while Serbia takes the responsibility for the promotion of green behavior in capital markets.

In March 2021, Serbia adopted the Law on Climate Change, which establishes a system for reducing greenhouse gas (hereinafter: GHG) emissions and contributing to the achievement of necessary GHG emissions in order to avoid adverse effects of climate change. The law harmonizes domestic legislation with EU regulations and directives and it is planned to be implemented with following strategies: 1) Low Carbon Development Strategy; 2) Action Plan for the Implementation of the Strategy; and 3) Programme of Adaptation to Changing Climatic Conditions. Later, in April 2021, the Law on the Use of Renewable Energy Sources was adopted with the purpose to accelerate the decarbonization of Serbia's energy sector.

The Republic of Serbia signed the Sofia Declaration on the Green Agenda for the Western Balkans in November 2020. By signing, Serbia committed to implementing of the following five pillars: 1) Climate, energy, mobility; 2) Circular economy; 3) Depollution; 4) Sustainable agriculture and food production; and 5) Biodiversity. The Green Bond Framework has been established to present details on obligations that the government intends to fulfill as an issuer of green bonds. The Framework is tailored to align with the Green Bond Principles, published in June 2021 by the International Capital Market Association (ICMA) and its four core components: use of proceeds; process for expenditure evaluation and selection; management of proceeds and reporting [18].

In September 2021, for the first time the Republic of Serbia issued a green Eurobond worth EUR 1.0 billion (issue date: 23 September 2021), with a maturity of seven years (i.e., 23 September 2028). The coupon rate was set at 1.00%, which is the lowest coupon rate ever, whilst a yield rate stood at 1.262%. Investor demand in the auction exceeded EUR 3 billion. Bonds are listed for trading on London Stock Exchange Regulated Market. The following ratings are assigned to these bonds: Standard & Poor's Global Ratings Europe Limited ("S&P"): BB+; Moody's

Investors Service, Inc. ("Moody's"): Ba2; Fitch Ratings Limited ("Fitch"): BB+. For comparative purposes, it is interesting that at the same time a conventional 15Y Eurobond was issued in amount of EUR 750 million (coupon rate 2.05% and a yield rate of 2.3%), while the demand for longest maturity Serbian Eurobond exceeded EUR 2.5 billion [19].

This green bond issuance established the Republic of Serbia as the only non-EU country which issued a green debt financial instrument. According to accepted obligations, collected funds will be used to finance or refinance expenditures aimed at the even more sustainable growth of the Serbian economy. Namely, it means that Serbia will be focused on investments in the following areas: renewable energy, energy efficiency, transport, sustainable water management and pollution, prevention, and control [20].

According to the Institutional Shareholder Services (hereinafter: ISS) ESG Country Rating the Republic of Serbia shows a medium sustainability performance on key ESG issues faced by sovereign issuers. The overall ISS ESG rating methodology is graded on a twelve-point scale from A+ (excellent performance) to D- (poor performance or country fails to demonstrate commitment). The country rating assigned to Serbia is C, which is marked as a moderate performance [21].

Successful issuance of green bonds is another important step in the recognition of the Republic of Serbia as a credible country in the eyes of reputable investors. It should be noted that since July 2021, dinar denominated bonds of the Republic of Serbia have been included in the J.P. Morgan GBI-EM Global Diversified index, one of the benchmark indices of bonds issued in local currencies of emerging economies. J.P. Morgan indices included three benchmark issues of dinar bonds with the original maturity of 7, 10 and 12.5 years, maturing in 2026, 2028 and 2032 respectively. The weight of dinar bonds in the GBI-EM Global Diversified index equals 0.3%. Additionally, these bonds are included in GBI-Aggregate (GBI-AGG) and GBI-AGG Diversified indices, which cover government bonds in domestic currencies of advanced and emerging economies, as well as in J.P. Morgan ESG (JESG) GBI-EM index, which incorporates ESG factors in decision-making on investment in fixed income assets [22].

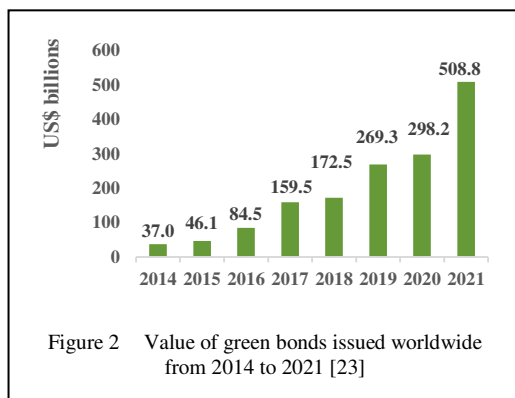

The growing popularity of green bonds as a financial instrument worldwide is justified with annual issuance in 2021 which exceeds US\$ 500 billion (see Fig. 2), with volume growth to hit US\$ 1 trillion. There was recorded significant growth in green bond issuance from financial and non-financial corporates, where both together represent 44% of cumulative green bond volume.

Among financial institutions, the largest single deal during 2021 was related to China Development Bank (valued at US\$ 6 billion), whilst in the non-financial sector the largest transaction was the issuance of the green bond by Ford Motor Company in the amount of US\$ 2.5 billion [24].

#### IV. CONCLUSION

There is no segment of society that is isolated from the climate changes and environmental protection which are taking place in our everyday life. Thus, it is wrong to present the tackle against climate change as something that only concerns the aspect of energy and the environment. Truly, above mentioned issue is a matter of achieving inter-generational justice as well as recognition of the future generations' right to a cleaner and better quality of life. Perhaps the most important segment is establishing cooperation between civil society organizations and the economy, as well as achieving the widest possible social consensus in the tackle against climate changes.

The transition toward the green economy is not something that can be postponed and wait for several decades or election cycles. In this sense, there is a high degree of social awareness in the Republic of Serbia that there may be material damage, financial

consequences, and loss of human life because the continuation of the environment destruction. On the wave of the global moment created by acceptance of the Paris Agreement, Serbia should use all advantages and define the directions of economic development for the next few decades.

Focusing on healthier life and consequently leading to the survival of our planet, one of the most actual segments of green behavior is ESG investing, particularly investing in green bonds. The green bond market worldwide experiences significant growth and a positive trajectory is continued despite of current Russia-Ukraine conflict and changes in the geopolitical sphere. The Republic of Serbia recognized the opportunities by widening the offer of financial instruments with issuance of the green Eurobond at a face value of EUR 1 billion on the London Stock Exchange in Q3 2021. Making a debut in the growing green bond market, which is primarily led by the engagement of European countries, Serbia made a huge step and gave optimism to the public and stakeholders that the Serbian capital market will be back on the positive path after almost one and a half decades of stagnation.

In this paper is given a comprehensive overview of the circumstances in the Serbian bond market during XXI century, with a general conclusion that almost all aspects (except government bonds) failed to crucially influence on capital market revival. Likewise, the equity market shared the destiny of the bond market, so the absence of IPOs and shallow liquidity are a burden for more than a decade. In described, not an idyllic picture, there is an upcoming phenomenon in the form of green bonds as a novel opportunity and new chance for the Serbian capital market development. Despite failures and negative past experiences in the bond market, Serbia has one more opportunity to develop its capital market. Certainly, green bond issuance will not be another fallacy in the market. On the contrary, authors' express the attitude that focusing on green bonds will create necessary preconditions for financing or refinancing projects which are primarily intended for environmental protection as an ultimate objective. Green bonds, as an innovative type of bonds, could be very useful tool for prospective green innovations and extension of green behavior in all spheres of business and life.

## REFERENCES

- [1] Republic of Serbia Securities Commission (2022). *New Law on the Capital Market bylaws come into force*. Available at: <https://sec.gov.rs/index.php/en/news/actual/780-new-law-on-the-capital-market-bylaws-come-into-force>.
- [2] World Bank (2019). *Capital market Development – Technical note*. Available at: <https://documents1.worldbank.org/curated/en/475341562570095897/pdf/Serbia-Capital-Market-Development-Technical-Note>.
- [3] Central Securities Depository and Clearing House (2022). *Review of frozen foreign currency savings deposits into the bonds of the Republic of Serbia and OTC trading*. Available at: <http://www.crhov.rs/index.cfm?Opcija=13&jezik=en>.
- [4] Miladinovski, S. (2012). *Razvoj tržišta dužničkih hartija od vrednosti – iskustvo i perspektive*. Available at: <http://www.belex.rs/k12/prezentacije/miladinovski.pdf>.
- [5] Uprava za javni dug, Ministarstvo finansija RS (2013). *Vodič za investiranje u državne hartije od vrednosti Republike Srbije*. Beograd.
- [6] National bank of Serbia (2020). *Korporativne obveznice u okviru monetarnih operacija – istine i zablude*. Available at: <https://www.nbs.rs/sr/scripts/showcontent/index.html?id=15796&konverzija=no>.
- [7] Mirković, V. & Andonović Brmalj, D. (2020). Uticaj pandemije koronavirusa na stabilnost finansijskog sistema Republike Srbije. *Ekonomski vidici, XXVI* (1-2), 169-187.
- [8] Danas (2020). *Šta znači kupovina korporativnih obveznica od strane NBS?* Available at: <https://www.danas.rs/vesti/ekonomija/sta-znaci-kupovina-korporativnih-obveznica-od-strane-nbs/>
- [9] Central Securities Depository and Clearing House (2022). *Aktivni FI registrovani u CR HoV – Korporativne obveznice*. Available at: <http://www.crhov.rs/?Opcija=5&TipHartije=kratkoročne>.
- [10] Mirković, V. & Lukić, J. (2017). Covered bonds: new opportunity for recovery of Serbian capital market. *FACTA Universitatis Series: Economics and Organization, 14*(4), 359-372.
- [11] Balkan Energy Green News (2018). *Fintel Energija uspešno zaključila prvi IPO u Srbiji nakon 80 godina – trgovanje počinje 20. novembra*. Available at: <https://balkangreenenergynews.com/rs/fintel-energija-uspesno-zakljucila-prvi-ipo-u-srbiji-nakon-80-godina-trgovanje-pocinje-20-novembra/>.
- [12] Peterdy, K. (2022). *What is ESG (Environmental, Social, and Governance)?* Available at: <https://corporatefinanceinstitute.com/resources/esg/esg-environmental-social-governance/>.
- [13] Vella, H. (2018). *Global Green Bond Partnership: reinvigorating green energy investment, again*. Available at: <https://www.power-technology.com/analysis/global-green-bond-partnership/>.
- [14] World Bank (2015). *What are green bonds?* Available at: <https://documents1.worldbank.org/curated/en/400251468187810398/pdf/99662-revised-wb-green-bond-box393208b-public.pdf>.
- [15] European Investment Bank (2022). *Climate Awareness Bonds*. Available at: [https://www.eib.org/en/OLD-investor\\_relations/cab/in dex.htm](https://www.eib.org/en/OLD-investor_relations/cab/in dex.htm)
- [16] World Bank (2022). *Environmental and Social Policies*. Available at: <https://www.worldbank.org/en/projects-operations/environmental-and-social-policies>.
- [17] Public Debt Administration (2021). *Green Bond Framework*. Available at: [http://javnidug.gov.rs/static/uploads/1438\\_Serbia%20Green%20Bond%20Framework\\_vf.pdf](http://javnidug.gov.rs/static/uploads/1438_Serbia%20Green%20Bond%20Framework_vf.pdf).
- [18] International Capital Market Association (2022). *Green Bond Principles (GBP)*. Available at: <https://www.icmagroup.org/sustainable-finance/the-principles-guidelines-and-handbooks/green-bond-principles-gbp/>.
- [19] Martin, V. (2021). Public Debt Management in Serbia. In *Proceedings of 3<sup>rd</sup> Virtual International Conference Path to a Knowledge Society-Managing Risks and Innovation* (pp. 117-123).
- [20] National bank of Serbia (2021). *Another Serbia's success in international market – lowest rate of financing and first green instrument*. Available at: <https://www.nbs.rs/en/scripts/showcontent/index.html?id=17355&konverzija=no>.
- [21] Public Debt Administration (2021). *Second Party Opinion (SPO)*. Available at: [http://javnidug.gov.rs/static/uploads/1439\\_Serbia\\_SPO\\_final.pdf](http://javnidug.gov.rs/static/uploads/1439_Serbia_SPO_final.pdf).
- [22] National bank of Serbia (2021). *Longstanding goal achieved – Serbia's dinar bonds included in renowned J.P. Morgan index family*. Available at: <https://www.nbs.rs/en/scripts/showcontent/index.html?id=17113&konverzija=no>.
- [23] Statista (2022). *Value of green bonds issued worldwide from 2014 to 2021*. Available at: <https://www.statista.com/statistics/1289406/green-bonds-issued-worldwide/>
- [24] The Global Treasurer (2022). *Green bond issuance soars as sustainable debt tops \$1trn in 2021*. Available at: <https://www.theglobaltreasurer.com/2022/05/06/green-bond-issuance-soars-as-sustainable-debt-tops-1trn-in-2021/>.

# Digital Transformation of Public Administration and Services in Hungary

Edit Soós<sup>1</sup>

<sup>1</sup>University of Szeged Faculty of Law and Political Sciences, Szeged, Hungary

<sup>1</sup>soos.edit@gmail.com

*Abstract*—The Government of Hungary launched the state territorial administration reform in 2010. The study examines the structural changes affecting territorial public administration under the influence of digitalisation. The anticipated trends of territorial administration development since 2010 are included in public policy strategic documents with designated intervention areas, which intended to create a public administration that is highly professional, and efficient with short administrative deadlines, thus creating service-oriented state operations enjoying the confidence of the public. Since 2010 the state administration and IT legislation have expanded and changed with the objective to replace paper-based administration with electronic administration. Digitalisation of public administration provides both public servants and citizens with a multitude of advantages. The process of digitalisation should give significant attention to citizens' needs. The latest developments show that clients have become very demanding in terms of public administration and require simple, fast, and transparent services. Efficient digitalisation must be an integrated process that creates a context favorable to the reviewing of administrative procedures and to makes them simpler. The paper presents the results of the Hungarian e-administration in the context of EU developments. To evaluate the performance of e-administration, the analysis uses the Digital Economy and Society Index (DESI), the data and reports of the e-Government Benchmark, which focuses on e-public administration, and the data of Eurostat.

**Keywords** - public administration, customer-friendly services, digital administration, front-office systems, back-office systems

## I. INTRODUCTION

The Government of Hungary (2010-2019) fundamentally reconstructed the central state system. The reforms launched in 2010, aiming at the central state administration, resulted in centralisation, further strengthening the role of the Prime Minister and further broadening the competence of its apparatus, organisational integration, and the reduction of the number of central authorities.

After the 2010 change of government, a complex public administration development programme was introduced, which is aimed at the renewal of public administration on a completely new basis. The directions of public administration development and the operating framework of Hungarian public administration were formalised in strategic documents. The goal of these documents is to improve the efficiency of the operation of the state and the quality of administrative services and to create an effective national public administration.

Public administration is concerned with the organisation, activities, and behaviour of administrative agencies and officials in the conduct of governance. It was an important strategic goal for Hungary to modernize its public administration and to increase the use of modern information and communication technologies in the interactions between state institutions themselves as well as between state institutions and citizens.

The objective of the study is to approach digitalisation transformation processes in public administration between 2010 and 2020. The

strategic governmental goal meets the expectations and challenges of the European Union towards Hungary to modernise its public administration and to increase the use of modern information and communication technologies (ICT) in the interactions among the state institutions themselves and between the state institutions and citizens.

The development process of the European integration prioritises answering the question of how public administration can be understood in the European standardisation process, especially at organisational-institutional level and with regard to the activities and operations of public administration. The deepening European integration brings forward the institutional harmonisation of the government systems of the EU Member States, particularly from a functional and value-oriented point of view. This process is about the unification of the member states' administrative authorities and their administrative procedures [1]. With all these taken into account a development of the European Administrative Space, as an informal entity, is a harmonized synthesis of values realized by the EU institutions and the Member States' administrative authorities through creating and applying the EU law [2]. This effort will result in the approximation of the national administrations of the Member States, bringing closer the administrative cultures and models on national administrations. These states have to take into consideration common values and administrative principles, such as reliability and predictability, accountability, openness and transparency, effectiveness and efficacy.

But, different countries need different governance systems in terms of both principles and structure. However preferable redesigns of governance depend significantly on specific conditions and problems. Before identifying the tasks of governance and working out required redesigns, we need to look at the environments within which governance will have to operate in the foreseeable future and the problem domains with which it will have to cope [3].

Member States are modernising their public administrations by introducing digital public services. "Development of the information society is not possible without a well-functioning electronic government (e-government)" [4]. The foundation of e-government are systems of electronic customer support (i.e. front-office systems) and systems responsible for supporting

internal processes and administrative procedures (i.e. back-office systems). Front-office is the outer sphere, providing customer service and customer contact with units of public administration. Front-office systems are therefore systems for electronic communication of clients with public administration units [5]. The structure of the article is as follows. The first part of the article describes the types of existing systems in public administration and briefly characterizes them. The author gives best practices and their use in Hungary with the following divisions: front-office systems, back-office systems, and integration of these systems. The last part of the article presents the findings of the study, as well as the achievements related to the use of ICT in public administration.

## II. REFORMS OF THE STATE ADMINISTRATION (2010-2020)

The Fundamental Law of Hungary, adopted on 25 April 2011, brought about radical changes in state administration [6]. The reform process has brought the effectiveness of the central government's decision-making system to the forefront in European terms, and without this, it would have been impossible to implement changes in the public administration system.

The directions of public administration development were formulated in the public policy strategic documents, the Magyary Zoltán Public Administration Development Programmes (MP 11.0, MP 12.0). In the Government Decree No. 1602/2014. (XI. 4.) [7] on the setting up of the State Reform Committee, the Government decided on the reform of state services, the reform of state administration services (in the framework of this, the creation of the national network of government windows), and the continuation of the transformation of the territorial public administration [8].

### A. *Reforms of the Territorial Public Administration (2011-2020)*

The territorial administration reform is part of the overall reform of public administration which was primarily triggered by a diagnosis of the weaknesses, inefficiencies, and bottlenecks in the structure of Hungarian public administration at all levels of government. As a result, the public administration lacked stability, predictability, certainty, and uniformity of process across the country and among the administrative actors involved in policy formulation, regulatory

decision-making and administrative service delivery [9].

As part of the operational and organizational renewal of the public administration, in accordance with Act CXXVI of 2010 (XI.19.) and the Government Decree No. 66/2015 (III. 30.), the capital and county government offices were established.<sup>1</sup> The altogether 20 government offices are located in the county seat cities and in the case of the capital city and Pest county in Budapest [10,11]. In accordance with Article 17(3) of the Fundamental Law, *'the capital or county government offices are the territorial state administration organs of the Government with general competence'*.

The tasks of government offices are to coordinate the implementation of government policies at the territorial level. They exercise coordinative, authority-type, proposing and consultative powers, allowing the adjustment of central decisions, and policies to territorial characteristics. The government offices are strictly controlled by the central government, and integrate a diverse set of special and general administration services [12]. With the establishment of capital and county government offices on the 1<sup>st</sup> of January 2011 the first phase of the integration of territorial state, the administration was completed.

An important step towards a less bureaucratic public administration was the setting up of the system of physical points of single contact. In January 2011, in accordance with Government Decree No. 288/2010 (XII.21.), Government Windows, an integrated network of service contact centres was established. The Government Windows started to operate as the front offices of Government Offices. The one-stop shops provide information and other administrative services from initiating and handling to closing a procedure to citizens in 3,000 different types of administrative cases. The delegated tasks show various pictures and embrace almost all public sector services (e.g. agriculture, employment and welfare benefits, personal document services (passport, ID card, driving license), vehicle administration, customer protection, national register tasks, etc.) For the general public, the Government

Windows represent a customer-friendly, single-window administration system. By 2019 there are altogether 295 Government Windows in Hungary which make it easier for citizens to personally administer their affairs, served by 36,000 civil servants.

In the second phase of systemic integration, on the 1<sup>st</sup> of January 2013, districts were established [13]. The administrative district offices comprise the lowest-level territorial units of state administration.

In accordance with Act XCIII of 2012 (VI.25) and Government Decree No. 218/2012. (VIII. 13.) on the district (capital's district) offices, there are 174 provincial offices and 23 in the capital were established [13,14]. Their function is to carry out administrative tasks below the county level. The districts grant the vast majority of public services to all Hungarian citizens. With the establishment of district offices, the goal of the Government is to create a customer-friendly administration, and modern administrative districts in order to help reduce costs to society and to operate more effectively and with more attention to the needs of the public.<sup>2</sup>

### III. DIGITAL TRANSFORMATION OF PUBLIC ADMINISTRATION AND SERVICES

In December 2020, the Hungarian government signed the Berlin Declaration on Digital Society and Value-Based Digital Government, thus reaffirming its commitment – together with other EU Member States – to foster digital transformation in order to allow citizens and businesses to harness the benefits and opportunities offered by modern digital technologies. The Declaration aims to contribute to a value-based digital transformation by addressing and strengthening digital participation and digital inclusion in European societies.

Technology is bringing innovative opportunities into the public sector and has the potential to improve interactions between governments and citizens through the simplification of procedures, as well as contribute to customer-friendly administration. The digital transformation of government means

<sup>1</sup>The capital and county government offices are led by government officials whose task is to coordinate and help the implementation of governmental tasks at a territorial level.

<sup>2</sup>The settlement structure of Hungary is laid down in the Constitution. Settlement-level units are villages, towns and

the capital, which necessarily cover the whole area of Hungary. Out of the 3,155 settlements of the country 346 are towns (1 of which is the capital and 23 are towns of county rank), and 2809 are villages.



the modernisation of public administration and enhanced digital interactions. There is growing interest in digital transformation that provides benefits for society at large.

The modernisation and transformation of electronic public administration in Hungary and the development of the necessary legal environment have been greatly influenced by EU requirements. The expectations of the EU are the informatisation, modernisation, and alignment of public administration.

Hungary has made decisive steps towards fostering interoperability and improving its e-Government systems within the framework of the comprehensive New Széchenyi Plan (2007-2013). Between 2007 and 2013 Hungary used European Union co-financed projects to develop the back office and front office functions of electronic public administration. These funds were available through the Electronic Administration Operational Programme (EAOP) and the State Reform Operational Programme (SROP).

Nevertheless, the use of e-services by its citizens was still below the EU average. In order to improve citizens' life quality, the competitiveness of businesses and the efficiency of the state a better understanding of public processes is needed in order to improve the networks, tools, services, and competences of public administrations.

The obligation to register companies online was announced in 2008 with the aim of reducing the number of paper forms. This obligation was preceded by the adoption of a Decree on intelligent e-Forms and a new Act on the e-Acknowledgement form. In addition, company registration was eased through the implementation of a simplified procedure that reduced the time needed for this process to a single hour.

The purpose of the Government is to accelerate procedures, reduce administrative burdens, more widely computerise state-to-citizen relations, ensure the cooperation of the bodies of e-administration, and provide the public with more modern and efficient public service. (During the deregulation process around 200 outdated e-Government-related regulations have been removed.)

The new legal framework gradually introduced after 2012 is open and technology neutral, thus can better adapt to changing

conditions caused by the fast development of ICT technologies. In April 2012 [15]., with the amendment of Act CXL of 2004 on the General Rules of Administrative Procedures and Services by Act CLXXIV of 2011, and the introduction of the so-called regulated electronic administration services, the legal preconditions for e-Government services were established [16]. In July 2015 a new law on the Hungarian e-ID card has been adopted, and the new card was issued at the beginning of 2016, replacing three different cards, hence further simplifying the lives of citizens.

One of the most important elements of the Hungarian e-Government strategy is the National Info-communication Strategy (NIS) 2014-2020 [17]. The purpose of this strategy was to give a comprehensive overview of the situation of the Hungarian information society and the ICT market, to define the ideal target situation, and to identify professional trends, and development targets in info-communications.

I made interviews with administrators and executives in public administration to reveal the relationships between public administration and customers with the aim of identifying problems arising when customers conduct their administrative affairs. The areas covered in the interviews – the digital infrastructure and digital competences – overlap the governmental intervention areas of the National Info-communication Strategy.

Based on their experience, civil servants identified several weaknesses of the transforming e-administration.

1. According to the opinion of civil servants it is necessary to organize IT training for administrators, organize e-administration training, improve technical conditions, operate a unified professional system, and provide information to customers.
2. The authority cannot expand beyond its sphere of competence, so problem-solving must be the most important aspect of decision-making. Therefore, it is important to have customer-friendly communication with the client. The most important expected behaviour for solving an emerging problem is professionalism, simplicity, and proper communication with customers by the agent after determining whether the client represents

a direct, definite, distant, or uncertain style.

3. There is a huge backlog with regard to digital illiteracy, the use of interactive technologies is still limited among the Hungarian population, and they do not have competitive knowledge. The same statement applies also to the employees and managers of enterprises, and there is also some backlog in the digital competencies of public administration employees.
4. It was important to develop electronic offices and systems which provide direct services to customers. The separation of front and back office functions began on a standardised basis and this helped to improve user satisfaction.
5. During the administration several e-interfaces are used: a General Form Filler Program (ÁNYK), Customer Access Portal (KRID Identifier), Document Management System (Poseidon, KÉR), Hungarian National Chamber of Civil Law Notaries (MOKKIT), Hungary's courts of law, e-KAT (document signing, verification, extension).
6. The use of e-interfaces requires different access codes; many e-systems have to be used; e-interfaces do not have a uniform datasheet; the filing system constantly changes (uploading and downloading documents, document management) in many cases the lack of proper technical background (computers are outdated).
7. There are more than 300 professional systems in Hungary that are not compatible with each other. The ongoing projects aim to create IT connections between them, making the administration simpler and faster, and becoming more customer-friendly.
8. The use of e-interfaces requires different access codes and, in many cases, there is a lack of technical background (computers are outdated).

During the 2014-2020 programming period, particular attention has been paid to the implementation of e-government projects co-financed by the European Union. In order to achieve this goal, the Public Administration and Public Service Development Operational

Programme (PADOP) invested over 935 million euros, including nearly €795 million from EU funding (75.7 % from the European Social Fund and 24.3 % from the Cohesion Fund), to reinforce the services provided by the public authorities.

The PADOP is in line with the Public Administration and Public Services Development Strategy 2014-2020 and the National Info-communication Strategy 2014-2020 of Hungary. In both of the strategies, the "Digital State" concept appears as one of the key areas that need to be developed. Both of these strategies emphasize the primary importance of interoperability. Therefore, the development of interoperability on the legal, organisational, semantic, and technical levels is an important objective within the projects financed by the PADOP.

As part of the implementation of strategic interoperability objectives of the European Union, the Hungarian Parliament adopted a law on interoperability, Act No. CCXX of 2013, on the general rules of cooperation between registries of the national and local governments. The intention of this law was to establish and increase cooperation between registries of national and local governments. The expected benefits were to increase the competitiveness of the state, increase the cost-efficiency of public administration operations, and promote cross-sector cooperation.

In order to create efficient digital services interoperability is required between IT systems and services. In 2015, the specific legislation on digital public administration was provided by Act No CCXXII of 2015 on the General Rules for Electronic Administration and Trust Services (e-Administration Act). The strategy aims at the development of the infrastructure required for the electronic services (IT, back office), the development of e-administration services, and their connection at an adequate level, with the greatest possible interoperability.

The e-Administration Act regulates cooperation in the field of information technology between bodies providing electronic administrative services, as well as interoperability. The e-Administration Act aims to achieve interoperability and cooperation between State registries. More specifically, it strongly encourages bodies to obtain information, decisions, and statements from cooperating bodies if the information, decisions,

or statements are made or already obtained by these cooperating bodies by electronic means. The cooperation includes government bodies, local authorities, other legal entities vested with administrative competence, court, public notaries, court bailiffs, public prosecutors, most of public utility companies, public service providers, and public sector companies. The legislation also allows the entities of the private sector to join this cooperation by considering themselves to be bound by the regulations of the Act.

#### IV. BEST PRACTICES

##### A. *Interoperability Platforms for Public Administrations and Local Governments*

The Hungarian Central Government Service Bus (KKSZB) is an interoperability platform that aims to ensure a service-oriented and standardised connection between national base registries and the different specific public administration information systems by unifying communication methods. More specifically, the KKSZB makes it possible to connect systems with different technological, operational, and integrational levels, as well as to reduce redundant data storage and data integrity errors resulting from former practices. The KKSZB ensures electronic communication, interoperability, and secure data exchange of authentic data among public administrative authorities.

The KKSZB may be joined by a service provider and client at the same time, making it technically possible for applications targeted at citizens and businesses to reach all services provided by the connected service providers via the KKSZB, as long as they have permission to do so. The KKSZB service bus will be a “plug-in” based system, to which any kind of service can be connected. In the year 2021 on the client side, 570 organisations or services are connected (175 in the live environment and 345 in the test environment).

According to the e-Administration Act, all public administration bodies providing e-Government services are obliged to publish their services on the SZÜF Portal. The new custom-friendly electronic administration user interface, SZÜF, has replaced the former magyarorszag.hu (hungary.hu) Portal is the point of the single contact portal of Hungary. The SZÜF Portal features a more modern design as well as a life-

event-based approach for publishing existing e-Government services.

##### B. *The Central Application Service Provider (ASP)*

Due to the need of spreading unified technical quality standards and ensuring optimal use of investment and operational resources, a centralised application service-providing model has been applied to promote local government digitalisation. The Central Application Service Provider (ASP) pilot was launched in 2015. The Hungarian Municipality ASP is a good practice of local government digitalisation aligned with the European Interoperability Framework which is a key instrument for establishing interoperable digital public services at all levels of public administration.

Based on the Application Service Provider’s central hardware and software infrastructure, the e-service provides integrated back-office systems (financial management software, municipal document management software, industrial and commercial management software, property cadastre, inheritance registration system, e-Administration web portal and online form management) for the daily tasks of the municipalities, as well as client-side e-Government services, on a single platform for all 3,155 municipalities connected. Another important benefit of the platform is that improves interoperability and reuse of existing solutions such as the regulated electronic administrative services provided by the state (the “building blocks” of electronic administrative processes), and fosters the once-only principle.

##### C. *The e-ID Cards for User Authentication*

A good example of reusing existing solutions is the use of e-ID cards for user authentication. As a result, the local government employees can only access the Municipality ASP’s applications by using their own electronic identity cards. Another example of reuse to highlight is the electronic administration service provision process, where the project has integrated the centrally provided regulated electronic administrative services to comply with e-Government policy criteria and the relevant legal provisions. It was also an important requirement that interconnection with external systems and base registries had to be done via the Central Governmental Service Bus (KKSZB) technical interoperability platform.

## V. CLOSING REMARKS

By 2018, the majority of public administration bodies providing digital public services had implemented at least the minimum level of provision of e-Government services, in accordance with the e-Administration Act. Throughout 2019 and 2020, the growing tendencies continued, as several developments have taken place leading to more modern, user-friendly electronic services.

The e-Government services provided access for citizens to the most important administrative affairs and the digital public services have played a key role in maintaining public trust in the state during the crisis.

The European Commission's European Interoperability Framework Monitoring Mechanism presents the overall good performance of Hungary, with particularly positive results within the Interoperability layers. Among the Priority areas of the e-Government Action Plan (2016-2020) is the User-Centricity. This indicates the extent to which a service is provided online, its mobile-friendliness, and the usability of the service (in terms of available online support and feedback mechanisms) (See Table I).

Civil servants argue that the electronic management of cases is a constraint, an unreasonable burden on customers who do not have the right competencies or sufficient background. The measure becomes customer-oriented when the concerned target groups – citizens, micro and small enterprises – have the appropriate IT skills (See Tables II and III.).

This process is promoted by the Superfast Internet Programme which was started in 2015 with the goal of providing at least 30Mbps broadband connection in every part of Hungary. As part of the Programme, 500,000 new network

TABLE I. E-GOVERNMENT PERFORMANCE ACROSS POLICY PRIORITIES IN THE FIELD OF USER-CENTRICITY.

User-centricity	EU average (2019)	Hungary (2019)	EU average (2020)	Hungary (2020)
online availability	86,8	83	87,2	91
usability	90,5	87	88,4	73
mobile friendliness	76,3	84	91,2	89

Source: *e-Government Benchmark Report Country Factsheets*

termination points were established by the end of 2018, with further developments underway. The Superfast Internet Programme 2.0 was launched in January 2019, aiming to further develop the networks, raise the capacity to at least 100Mbps available anywhere in the country, and further develop optical networks with Gigabit capabilities to expand the Gigabit broadband network coverage. In 2020, the Hungarian government plans to adopt the Gigabit Hungary Strategy that, in line with EU goals, aims to cover the whole territory of the country with at least 1Gbps per household and enterprise by 2030.

In sum, Hungary ranks 22nd out of the 27 EU Member States in the Digital Economy and Society Index (DESI) 2022 [18]. On Human capital, the country ranks 23rd, scoring 38 compared to the EU average of 46. 49% of individuals have at least basic digital skills, below the EU average of 54%. 3.1% of graduates studied ICT (EU average: 3.9%), and ICT specialists still represent a relatively low share of the workforce (3.9% versus 4.5% in the EU).

Although there was progress in the digitalization of enterprises in 2021, most Hungarian enterprises do not exploit the opportunities offered by digital technologies. 21% of the companies use enterprise resource planning software to share information electronically (EU average: 38%), and 13% rely

TABLE II. PERCENTAGE OF INDIVIDUALS USING THE INTERNET FOR INTERACTION WITH PUBLIC AUTHORITIES.

	2012	2013	2014	2015	2016	2017	2018	2019	2020	2021
Hungary %	42	37	49	42	48	47	53	53	60	73
EU average %	44	42	46	46	48	49	52	55	57	58

Source: *Eurostat Information Society Indicators*

TABLE III. INTERNET USE: SUBMITTING COMPLETED FORMS.

	2012	2013	2014	2015	2016	2017	2018	2019	2020	2021
Hungary %	20	18	24	24	24	29	37	39	37	66
EU average %	22	21	25	25	27	29	33	36	38	44

Source: *Eurostat Information Society Indicators*

on social media (EU average: 29%) or send e-invoices (EU average: 32%) [18].

Hungary can only perform well if the obstacles blocking the further upswing of the sector are considerably and consistently dismantled in the future.

#### ACKNOWLEDGMENT

The research was supported by the ICT and Societal Challenges Competence Centre of the Humanities and Social Sciences Cluster of the Centre of Excellence for Interdisciplinary Research, Development and Innovation of the University of Szeged. The author is a member of the Digitalization and Democracy research group.

#### REFERENCES

- [1] Torma, A. (2011). The European Administrative Space (EAS). *European Integration Studies*, (9)1, 149–161.
- [2] Csatlós, E. (2016). Perspectives of the Cooperation of National Administrative Authorities in the EU. *Jogelméleti Szemle*, (3), 45-55.
- [3] Dror, Y. (2002). *The capacity to govern. A report to the Club of Rome*. London-Portland-Or: Frank Cass Publishers.
- [4] Ziemia, E. (2012). *Miejsce e-administracji w kreowaniu społeczeństwa informacyjnego – teoria i praktyka*. Roczniki Kolegium Analiz Ekonomicznych SGH, (24), Oficyna Wydawnicza SGH, Warszawa.
- [5] Descours, D. (2015). Front-office and back-office systems in public administration units in Silesian voivodship. *Studia Ekonomiczne. Zeszyty Naukowe Uniwersytetu Ekonomicznego w Katowicach*, (278), 120-140.
- [6] The Fundamental Law of Hungary. (2010). (25 April 2011)
- [7] Government Decree 1602/2014.(XI. 4.) on the setting up of the State Reform Committee.
- [8] Horváth, I. L. (2017). The reform of the territorial public administration from 2010 to the present, with special emphasis on the re-interpretation of the customer-service model. *Új Magyar Közigazgatás*, (10)1, 22-31.
- [9] Magyary Zoltán Public Administration Development Programme. Ministry of Public Administration and Justice, Government of Hungary, Budapest, 10 June 2011.
- [10] Act CXXVI of 2010 (19. XI. 2010) on the capital and county government offices, the amendment of territorial integrity, and the establishment of the capital and county government offices.
- [11] Government Decree No. 66/2015. (III. 30.) on the capital and county government offices and the district (capital's district) offices.
- [12] Hajnal, Gy. & Kovács, É. (2013). *Coordination practice. Government windows: One-stop shops for administrative services in Hungary*. Budapest: Corvinus University, COCOPS.
- [13] Act XCIII of 2012 (25. VI. 2012) on the formation of the districts and on the necessary amendments of the related acts.
- [14] Government Decree No. 218/2012. (VIII. 13.) on the district (capital's district) offices.
- [15] Act CXL of 2004 on the General Rules of Administrative Proceedings and Services
- [16] Act CLXXIV of 2011 on the amendment of the Act CXL of 2004 on the General Rules of Administrative Procedures and Services.
- [17] National Infocommunication Strategy (2014-2020). Development Strategy of the Infocommunications Sector (2014-2020).
- [18] European Commission. (2022). *Digital Economy and Society Index (DESI)*. Hungary.

# Contemporary Tendencies and Barriers in Knowledge Management in Tourism

Borislav Kolarić<sup>1</sup>, Goran Stojićević<sup>2</sup>, Jelena Ignjatović<sup>3</sup>, Aleksandra Đorđević<sup>4</sup>

<sup>1,2,3,4</sup>Academy of Applied Studies Šabac, Šabac, Serbia

<sup>1</sup>kayak@mts.rs, <sup>2</sup>csugoran@mail.com, <sup>3</sup>jignjatovic985@mail.com, <sup>4</sup>aleksandradj993@mail.com

**Abstract**—The modern business environment is changing rapidly, creating unpredictable competitive challenges. The tourism and hospitality industries are particularly susceptible to such unplanned changes and are forced to react quickly in order to resolve adverse business situations. In a rapidly changing global business, knowledge management has become an integral part of business strategy. Knowledge is recognized as a rather powerful tool that supports organizations and the entire tourism industry in creating an effective model for achieving competitive advantage and achieving the desired business performance. Many business organizations have implemented these strategies or are in the process of implementing them. The purpose of the paper is to present the importance of knowledge management in the modern challenges of tourism business, as well as to propose the conditions necessary for successful implementation. In addition to the introduction, the paper consists of three parts. The first part of the paper points out the importance of knowledge management both in the global context and as a contribution to the development of tourism. The second part of the paper is focused on the barriers that may appear in knowledge management processes, while the third part presents some methods that can be used to avoid the mentioned barriers and thereby create conditions for the successful implementation of knowledge management. At the end, the concluding considerations of the author are given.

**Keywords** – tendencies, barriers, knowledge management, tourism.

## I. INTRODUCTION

Changes in the business world and the modern market environment impose the need for changes in organizational management. Business processes are changing the focus from industrial production to knowledge and information, with the help of information technologies that support them. The intellectual capital of the company includes the intellect of the employees, "know-how", as well as the processes of creating knowledge. Generating and using new knowledge to encourage innovation, in the function of developing a new product or service, plays one of the key roles for competitiveness in all spheres of business operations, including the tourism sector. Although the key role of knowledge as a competitive tool has long been recognized, the emergence of knowledge management as an academic field is much more recent. The more significant role of knowledge management, in the function of increasing organizational performance and gaining competitive advantage, dates to the beginning of the 80s. As a competitive tool, process fundamentals include the identification of relevant knowledge and its collection, transfer and sharing, as well as provision, in the sense that organizations are designed to optimize flows and manage them effectively. This requires an open decentralized environment where individuals are empowered to see knowledge as a resource to be shared, not hoarded. The knowledge of employees, who are able to use it, generates new ideas that are essential for gaining a competitive advantage.

The role of knowledge management in the tourism sector is reflected in providing employees with easy access to the latest, specialized knowledge. This is especially important in the hospitality industry because the success of the facility depends on providing guests with an excellent experience. If employees are slow to provide accurate information or solutions, the customer is less likely to return, or may even show their dissatisfaction through negative “word of mouth” or negative reviews on social media. A knowledge management solution is a system that enables a tourism institution to store and organize the collective knowledge of its employees. This enables the collection of individual employee knowledge and its transformation into organizational knowledge, which remains even if the employee leaves the organization. This creates a centralized source of knowledge that employees can easily access to learn company policies, procedures, best practices, and other relevant job information.

The goal of modern business is the development of an organizational structure and culture, in which knowledge is easily shared among the members of the organization, both through social and electronic networks. In contrast to the transfer of explicit knowledge, there is the issue of sharing implicit knowledge among organizational members. The degree of its disclosure and sharing within the organization can largely determine the level of competitive advantage. For an organization that wants to successfully adopt knowledge management (KM), the practice of knowledge sharing must be integrated into the daily routines of the organization's employees. However, there are many factors that can have a negative impact on the successful exchange of knowledge within an organization, known as KM barriers. They most often appear as a product of the imperfection of the organizational structure and organizational culture, but they can also come from sources that are not directly under the control of the organization.

## II. IMPORTANCE AND CHARACTERISTICS OF KNOWLEDGE MANAGEMENT

Knowledge can be defined as a fluid mixture of framed experiences, values, contextual information, and expert insight, which provide a framework for evaluating and incorporating new experiences and information [1]. In an

organization, it is embedded in the minds of employees, as well as in organizational routines, processes, practices, and norms, which are sometimes called socially constructed patterns [2]. Knowledge represents a well-organized combination of information, assimilated within a set of rules, procedures, and operations, learned through experience and practice [3]. The literature has classified knowledge into two main types: tacit and explicit. Explicit knowledge is knowledge that can be seen, shared, and easily communicated to others. It is often referred to as “know-what” and can be represented in both words and numbers and as such could be shared in manuals, specifications, and data science [4]. In support of the above, Smith adds that knowledge can be stored in a codified form in databases on different types of media so that [5]:

- can easily be transferred to the recipient without any misunderstandings;
- can be reused for different purposes within organizations.

The most explicit knowledge is in the form of raw data, such as documents containing staff work experiences, descriptions of events, interpretations of data, beliefs, guesses, hunches, ideas, opinions, judgments, and proposed actions [6].

On the other hand, Nonaka describes tacit knowledge as “know-how” knowledge, which depends on personal skills, expertise and develops through training and experience, while it is difficult to transfer through communication with others [7].

Tacit knowledge is harder to share because it is embedded in a person's memory. DeLong and Fahey (2000) described tacit knowledge as what we know but cannot explain [8]. These authors indicate that tacit knowledge is:

- embodied in mental processes;
- derives from practice and experience;
- expressed through applications of abilities;
- transmitted in the form of learning by doing and watching.

Knowing how to solve a problem using tacit knowledge refers to personal interpretation, abilities, and skills [9]. Tacit knowledge depends on personal skills, expertise and is developed

through training and experience, and is difficult to transfer through communication with others.

The realization of organizational knowledge depends on the people who interpret, organize, plan, develop and execute those socially constructed templates. Most importantly, organizational knowledge depends on specific situations and does not always depend on absolute truths or quantitative facts.

Therefore, it can be concluded that organizational knowledge has some characteristics. They refer to the subtle, implicit, built-in, sometimes invisible knowledge, assumptions, values, and mindset that pervade an employee's behavior, decisions, and actions.

### III. THE ROLE OF KNOWLEDGE MANAGEMENT IN TOURISM

The structural complexity and integration of different service sectors means that tourism needs to be constantly renewed in order to compete with the diversity of options and competitors in the world. Tourism, as an industry that provides services to a large extent, depends on the quality of human capital and the key competencies and knowledge they possess.

The importance of knowledge in tourism is becoming greater, due to the specificity it possesses, the characteristics of the products and services it offers, as well as the clients themselves and the services they use [10].

In an economy characterized by experience and knowledge, tourists are looking for more personal and transformational experiences, which requires constant innovation and adaptation to attract new customers and retain existing ones. Kirillova (2016) state that the knowledge economy shifts the axis of wealth to sectors where products and processes are intensive in knowledge, intelligence, and technology [11]. Show and Williams (2009) emphasize the importance of knowledge as one of the most powerful drivers of innovation, productivity, and competitiveness in tourism [12].

Knowledge management and its dimensions are essential for the sustainability of organizations [13]. The role of knowledge is recognized as a relevant factor for planning sustainable activities in tourism [14]. Knowledge management has been analyzed in various studies, which enabled the determination of the impact of KM on innovation constructions [15].

It is an input for the development of innovative products and processes. Knowledge is a highly sought-after resource in the present time, because there is a lot of volatility and fluidity, which forces tourism destinations and their businesses to become dynamic and innovative [16]. In such an environment, Tussiadiah (2014) understands that it is necessary to offer differentiated and exclusive products and services, which cause unforgettable experiences, to stand out and survive in the market [17].

Tourism is very specific in terms of the balance between client expectations and reality, as well as the balance of "supply and demand". It is necessary to create a well-organized system of knowledge and management in the destination, so that subjects can:

- create knowledge about the destination (for its economic, cultural, historical, and ecological values);
- collect and analyze existing knowledge (especially knowledge about good practice);
- ensuring access to knowledge to all interested parties and the public, etc.

### IV. BARRIERS IN KNOWLEDGE MANAGEMENT PROCESSES

Knowledge sharing is defined as a process in which individuals exchange knowledge, which includes their work experience, expertise, know-how, information, ideas, and suggestions that jointly create new knowledge [18]. The existence of informal and formal mechanisms in knowledge exchange strategies, within organizations, is necessary for such strategies to be implemented.

The absence of these mechanisms is considered one of the relevant barriers for knowledge sharing and acquisition. In addition, the process of codifying knowledge in databases is often complicated and unclear, creating difficulty when attempting to access or retrieve knowledge from databases [19]. On the other hand, employees often do not have time to communicate with each other due to workload, which is an inhibiting factor in the knowledge exchange process [20].

An organization rarely has a unique culture because each employee has a subculture, which differs from the subcultures of other employees, which makes it difficult to build collective



practices and procedures [21]. The boundaries of functional departments and the arrangement of work activities by premises greatly influence knowledge exchange activities among employees [20]. A motivational moment must be added to all the above. Motivation is considered one of the main factors needed in the development of the organization, in the direction of knowledge exchange, which should be designed and formulated considering the different needs and expectations of employees. Motivation can be provided through the recognition and inclusion of knowledge performance in performance evaluation systems [22]. When motivated, employees share knowledge easily. If there is a lack of management and leadership, who will only expect their employees to share their thoughts and ideas, just because it is the right thing to do, the processes and exchange of knowledge within the organization will not come to life [23]. Long (1997) sees the main sources of barriers in KM processes within organizational culture and technological infrastructure [24]. Singh and Kant (2007), expand on the potential causes of barriers in KM processes, emphasizing the importance of motivation and rewards [25]. To the above, Črnjar and Dlačić (2014) add the factor of human resources as a significant barrier in the implementation of KM [26]. They concluded that potential HR barriers are cultural effects, personal anxiety, resistance to change and inadequate motivation policies.

Technological infrastructure provides great support in KM processes. A wide range of

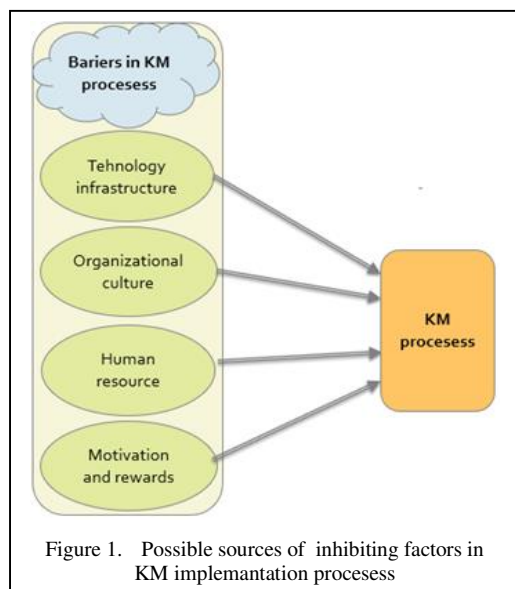

technologies such as business intelligence, knowledge base, collaboration, portals, user management systems, data collection, workflow support KM activities, while the choice of appropriate technology improves company performance [25]. Technological infrastructure enables data collection, definition, storage, indexing and linking of data and digital objects to support management decisions [27]. The lack of technological infrastructure is one of the obstacles in the implementation of KM.

Riege (2005) hypothesized that technological barriers to KM can be summarized as follows [23]:

- legacy systems cause a lack of integration between systems and operational processes;
- faulty business software system;
- lack of maintenance and updating of software and hardware;
- technical support of the IT system hinders communication flows and knowledge exchange;
- employees are unable to predict what the new technology can and cannot do;
- the mismatch between integrated IT systems and the needs of individuals limits the sharing process;
- lack of understanding, training, familiarization, and experience of the objectives, uses and benefits KM;
- increase resistance to the use of new KM systems.

Organizational culture defines basic beliefs, value norms and social customs, which govern the way individuals act and behave in the organization. It is the sum of shared philosophies, assumptions, values, expectations, attitudes, and norms that bind organizations together [28]. McDermott and O'Dell (2001) place culture as one of the key inhibitors of KM implementation [21]. A good organizational culture implies cooperation and trust. Trust is one of the aspects of knowledge-friendly cultures, which fosters the relationship between individuals and groups, thus enabling a more proactive and open exchange of knowledge [29].

The absence or minimal level of cooperation hinders the transfer of knowledge between individuals and groups. Also, if the organization

does not have an appropriate organizational culture, which includes a reward system for knowledge exchange, methods of encouraging cooperation among employees and management support, the implementation of the knowledge management process will not have adequate support [30]. In most cases, employees are reluctant to share their knowledge with others because they fear losing their jobs. In the last case, they will share it only with selected employees [31]. Similarly, some managers are afraid of sharing their partial or more complex knowledge because it could affect the rate of growth and promotion of their subordinates, relative to themselves, which could lead to them losing their position. They believe that knowledge is the source of power and success. All the above causes a loss of willingness and motivation to share knowledge among employees, which leads to limited knowledge sharing and which results in the obstruction of the knowledge management process [32]. Organizational goals cannot be achieved if organizations do not integrate the concept of motivation and rewards for their employees. Motivation can be provided through recognition, visibility, and inclusion of knowledge performance in assessment systems and incentives [22]. Motivation can be internal or external. Rewarding and recognizing an employee, in tangible form for their efforts to share knowledge, is extrinsic motivation, while intrinsic motivation is intangible in nature [33]. Employees easily share their knowledge when they are motivated. It is crucial for the exchange of both types of knowledge, tacit and explicit knowledge. Lack of motivation and reward system is also an obstacle, as it discourages people to create, share and use knowledge. Without establishing organizational reward and recognition systems, it is very difficult to align KM with the business needs of organizations.

#### V. METHODS OF SUCCESSFUL IMPLEMENTATION OF KNOWLEDGE MANAGEMENT

There is a great benefit to knowledge, which flows freely through the organization. However, various cultural, social, and technological barriers often limit the effective flow of knowledge among workers. Organizational culture affects the level of cooperation within the organization, and good cooperation is the key to successful knowledge exchange. As noted by Sveibi and Simmons (2002), a collaborative climate was one of the main factors affecting the

effectiveness of knowledge programs, as it improves knowledge sharing and organizational effectiveness [34]. To achieve high innovation performance, in service tourism organizations, a better team culture, which supports the exchange of knowledge, must be developed. The literature related to the implementation of KM indicates that certain factors such as a climate of trust and openness, a smoother organizational structure, management support for multifunctional cooperation and teamwork, as well as the application of modern information technologies play a very important role in the success of a KM project.

Widen-Wulff and Suomi (2007) developed a framework for creating an organization-wide knowledge sharing information culture that includes knowledge sourcing, organizational learning, and business process reengineering [35]. They are of the opinion that the organization must provide basic resources such as technology. When resources become available, the organization should ensure that basic resources are converted into competence, that is, that employees know how to use these resources. The authors also argue that the concept of organizational learning must be embedded in the organization. Most importantly, recognize that an organization's workforce is more than just a collection of skilled individuals. These experts must adapt their skills to be able to distribute their expertise through formal and informal networks.

Cross et al. (2001) suggested mapping knowledge flows across different boundaries in an organization to gain critical insight into where management should focus efforts to promote collaboration [36]. Knowing what someone else knows (knowledge) is a precursor to looking for a specific person, when faced with a problem that needs a solution. However, knowing who to contact is only useful if that person can be reached in time. Access is influenced by the closeness of one's relationship, as well as physical proximity, organizational design, and use of collaborative technology. Once access is available, knowledge can only be shared if the expert understands the problem, as experienced by the person seeking help (engagement). At this point, the expert can shape his knowledge to help solve the problem. Finally, the safety of the person seeking the knowledge is of utmost concern. Being able to admit a lack of knowledge and ask for help results in creativity and learning.

Cross et al. (2001) believe that it is particularly important to identify the points of creation and exchange of knowledge that have strategic importance [36]. Examples of domains that could yield this type of benefit include senior management networks, collaborative initiatives, joint ventures, alliances, and communities of practice. Communities of practice are a common knowledge sharing or transfer technique. In a Community of Practice, groups of individuals share knowledge of common work practice over a period of time, even though they are not part of a formally constituted work team. Communities of practice often cut across traditional organizational boundaries. The purpose of this organizational structure is to enable individuals to acquire new knowledge more quickly [37].

Speaking about social groups, it should be understood that the collective knowledge of teams or groups represents the intellectual wealth of many institutions. In this direction, knowledge management can be viewed as a harmonious working environment in which employees [38]:

- store best practices in knowledge repositories;
- talk to colleagues;
- write reports and analyses;
- openly express their comments and give suggestions and answers;
- document their insights into problems,
- use the existing knowledge base to accomplish their tasks.

## VI. CONCLUSION

Progress, not only of companies but also of society, is based on knowledge, its sharing, transfer, and reuse. Management of strategic, key knowledge in an enterprise becomes a critical factor in achieving sustainable business development in the time of a rapidly changing world.

Effective and active knowledge management requires a new perspective and tools that should consider almost all factors in the enterprise. Tourism, as one of the most dominant economic branches today, requires high quality, accuracy in the exchange of information and constant work and investments. The development of tourism and hospitality is continuously influenced by a wide range of different economic, social, political, environmental, and

technological challenges and opportunities such as: the constant development and growth of tourism, the development and transformation of visitor demand, the increase in travel mobility and the rapid development of technologies. In this sense, the adoption of a knowledge perspective in the tourism sector is one of the prerequisites (along with investments and financing) for the transformation of the tourism sector into a sustainable, resource-efficient, and socially inclusive environment.

A culture must be created, which will improve the exchange of knowledge and the acceptance of knowledge management. It is necessary to find the best way to implement knowledge into the company's business strategy. Also, an effective knowledge management system must include all employees in a kind of knowledge community, which uses, shares and transfers knowledge. The key is that management cannot just expect knowledge sharing to happen on its own. Instead, management must be the driver of knowledge sharing within the organization.

## REFERENCES

- [1] Davenport, T. H., & Prusak, L. (2000). *Working knowledge: How organizations manage what they know*. Boston: Harvard Business School Press.
- [2] Guzman, G. A. C., & Wilson, J. (2005). The "soft" dimension of organizational knowledge transfer. *Journal of Knowledge Management*, 9(2), 59-74.
- [3] Keskin, H. (2005). The relationships between explicit and tacit oriented knowledge management strategy, and firm performance. *Journal of American Academy of Business*, 7(1), 169-175.
- [4] Nonaka, I., Toyama, R., & Nagata, A. (2000). A firm as a knowledge-creating entity: A new perspective on the theory of the firm. *Industrial and Corporate Change*, 9(1), 1-20.
- [5] Smith, R. (2001). The role of tacit and explicit knowledge in the workplace. *Journal of Knowledge Management*, 5(4), 311-321.
- [6] Choo, S. W. (2000). Working with knowledge: How information professionals help organizations management what they know. *Library Management*, 21(8), 395.
- [7] Nonaka, I. (1994). Dynamic Theory of Organizational Knowledge Creation. *Organization Science*, 5(1), 14-37.
- [8] DeLong, D. & Fahey, L. (2000). Diagnosing cultural barriers to knowledge management. *Academy of Management Executive*, 14(4), 113-127.
- [9] Abdullah, F., Ingram, A. & Welsh, R. (2009). Managers' perceptions of tacit knowledge in Edimburgh's Indian restaurants. *International Journal of Contemporary Hospitality Management*, 21(1), 118-127.

- [10] Vujić, V., Črnjar, K. & Maškarin, H. (2009). Knowledge and education of human resources in the Croatian hospitality industry. In *4th International Scientific Conference: Planning for the Future, Learning from the Past*. Rhodes Island, Greece.
- [11] Kirillova, K., Lehto, X., & Cai, L. (2016). Existential Authenticity and Anxiety as Outcomes: The Tourist in the Experience Economy. *International Journal of Tourism Research*, 19(1), 13-26.
- [12] Shaw, Gareth, & Allan Williams. (2009). Knowledge transfer and management in tourism organizations: an emerging research agenda. *Tourism Management* 30, 325-335.
- [13] Kavalić, M., Nikolić, M., Radosav, D., Stanisavljev, S. & Pečujlija, M. (2021). Influencing factors on knowledge management for organizational sustainability. *Sustainability*, 13, 1497.
- [14] Gloet, M.; Samson, D. (2020). Knowledge and Innovation Management to Support Supply Chain Innovation and Sustainability Practices. *Inf. Syst. Manag.*, 1–16.
- [15] Ode, E. & Ayavoo, R. (2020). The mediating role of knowledge application in the relationship between knowledge management practices and firm innovation. *J. Innov. Knowl.* 5, 210–218.
- [16] Tuominen, P. P., & Ascenção, M. P. (2016). The hotel of tomorrow: A service design approach. *Journal of Vacation Marketing*, 22(3), 279-292.
- [17] Tussyadih, I. P. (2014). Toward a theoretical foundation for experience design in tourism. *Journal of Travel Research*, 53(5), 543-564.
- [18] Kim, T. T., & Lee, G. (2013). Hospitality employee knowledge-sharing behaviors in the relationship between goal orientations and service innovative behavior. *International Journal of Hospitality Management*, 34, 324–337.
- [19] Santos, V., Goldman, A., & Souza. (2012). *Fostering inter-team knowledge sharing effectiveness in agile software development*, Technical Report: RT-MAC-2012-02.
- [20] Awang, M., Kareem, O., & Ismai, R. (2014). Sharing is Caring. Why do we have Barriers in Knowledge Sharing. *Journal of Distance Education and e-Learning*, 2 (2), 25-33.
- [21] McDermott, R., & O'Dell, C. (2001). Overcoming cultural barriers to sharing knowledge. *Journal of Knowledge Management*, 5 (1), pp. 76–85.
- [22] Hariharan A. (2002). Knowledge management: A strategic tool. *Journal of Knowledge Management Practice*, 2002, 3, 50-59.
- [23] Riege, A. (2005). Three-dozen knowledge-sharing barriers managers must consider. *Journal of Knowledge Management*, 9(3), 18–35.
- [24] Long, D. D. (1997). *Building the Knowledge-Based Organization: How Culture drives Knowledge Behaviors*. Working paper, Center for Business Innovation.
- [25] Singh M., Kant.R. (2007). Knowledge management enablers: An interpretive structural modeling approach. In: *Proc. Of the 8th European Conference on Knowledge Management* (pp. 915–923), Barcelona, Spain, 6-7 September.
- [26] Črnjar K. & Dlačić, J. (2014). Critical success factors for knowledge management Implementation in hotel enterprises. Human capital without boarder: knowledge, and learning for quality of life. *Management, knowledge and learning. International conference* (pp. 25-27), Portoroz, Slovenia.
- [27] Carneiro, A. (2001). The role of intelligent resources in knowledge management. *Journal of Knowledge Management*, 5(4), 358–367.
- [28] Lemken, B. Kahler H. & Rittenbruch. M. (2000). Sustained knowledge management by organizational culture. In *Proc. Of the 33rd Hawaii International Conference on System Sciences* (pp. 64).
- [29] Alawi A., Marzooqi A. & Mohammed Y. (2007). Organizational culture and knowledge sharing: critical success factors. *Journal of Knowledge Management* 11(2), 22–42.
- [30] Khajouei, H., Jamshidi, M.J.; & Nasrabadi, H. (2016). Investigation and prioritization of cultural barriers against implementation of knowledge management in Kerman Regional Electric Company. *International Journal of Knowledge Management Studies*, 7(3-4), 257-269.
- [31] Uriarte, F.A., (2008). Introduction to knowledge management. *ASEAN Found.*, 45–65.
- [32] Yih-Tong, S.P. & Scott, J. (2005). An investigation of barriers to knowledge transfer. *Journal of Knowledge Management*, 9(2), 75-90.
- [33] Bhirud, S. Rodrigues, L. & Desai P. (2005). Knowledge sharing practices in km: A case study in indian software subsidiary. *Journal of Knowledge Management Practice*, 6.
- [34] Sveiby, K. E., & Simons, R. (2002). Collaborative climate and effectiveness of knowledge work. *Journal of Knowledge Management*, 6(5), 420-433.
- [35] Widen-Wulff, G., & Suomi, R. (2007). Utilization of information resources for business success: The knowledge sharing model. *Information Resources Management Journal*, 20(1), 46-67.
- [36] Cross, R., Parker, A., Prusak, L., & Borgatti, S. P. (2001). Knowing what we know: Supporting knowledge creation and sharing in social networks. *Organizational Dynamics*, 30(2), 100-120.
- [37] Jakobson, L. (2008). Save the knowledge. *Incentive*, 182(2), pp 42-43.
- [38] Disterer, G. (2001). Individual and social barriers to knowledge transfer. *Proceedings of the 34th Hawaii international conference on system sciences*.



# The Foundations for the Future Innovation Ecosystem - A Digital Twins Framework Approach

Branko Perišić<sup>1</sup>, Ana Perišić<sup>2</sup>

<sup>1</sup>Singidunum University, Belgrade, Center Novi Sad, Novi Sad, Serbia

<sup>2</sup>Faculty of Technical Sciences, University of Novi Sad, Novi Sad, Serbia

<sup>1</sup>bperisic@singidunum.ac.rs, <sup>2</sup>anaperisic@uns.ac.rs

**Abstract**—Innovations are the main drivers of overall social progress that exhibits its value delivery mission in the contemporary context, where the term ecosystem attributes that particular context. The innovation ecosystem is a composite entity encapsulating structural and behavioral dimensions of participating systems, integrated into a hyper-system-of-systems space. Its inherent complexity demands the specification, modeling, and development of appropriate *digital twin*. This work presents the conceptual model of the digital twin as a software-empowered framework. It assumes the creative interoperability of two essential innovations domain driving forces learning and performing as innovations reflections.

**Keywords:** innovation ecosystem, digital twins, software frameworks, system-of-systems, hyper-heli-model

## I. INTRODUCTION

Innovation is an old and traditional area of social research that has shaped society through every historical epoch or stage. Modern, post-industrial edge is mainly driven by constant change as the origin of all known progress. The innovation thereby appears as a mutable hyper-dimensional concept. Currently, it is dominantly reflexive on its knowledge foundations. Innovation is decentralized and depersonalized through a group rather than individual endeavors, heterogeneous due to widespread over global performing networks, and ubiquitous by its very essence [1]. In published articles and conference papers, the innovation definition and modeling aspects, have been elaborated in different contexts. The empirical

work analysis shows that the majority of innovations emerge from Science and Technology Studies, Economics, and Economics geography [2].

The inherent complexity of individual problem domains induces a model-driven approach. Modeling is a well-established paradigm for coping with complexity. The abstraction level of model ingredients directs its expressiveness and usability regarding particular context structure and behavior. The popularity of combinatorial complexity representation by biological helix-based models (DNA) has founded the concept of sustainable ecology in the innovations domain. The introduction of the innovation ecosystem concept directly influenced past, current, and future research and development activities and emerged with the establishment of different innovation ecosystem frameworks.

The proliferation of information and communication technologies has dramatically changed the innovation domains transposing them into digital transformation. Mapping between problem domains and corresponding digital transformation solution domains emerged throughout the “digital twin” concept promoting an innovation ecosystem paradigm as problem domain abstraction. It ultimately leads to the model-based software framework specification and development as a driving idea of our research directions. The rest of the paper has the following structure:

- The conceptual background section elaborates on the relevant referent



research and concepts that influenced it;

- Framework foundations are discussed in section III, while section IV contains the proposed software framework concepts, principles, and model fundamentals;
- The concluding section summarizes the fundamental framework advantages and opens further research and development directions.

## II. CONCEPTUAL BACKGROUND

The conceptual background of innovation ecosystem framework development has a long tradition in publications concerning the technology's impact on social development. The cross-reference analysis of representative publications distinguishes several mainstream directions:

- The first is the transition from an innovation system to an innovation ecosystem through extensive concept formulations and definitions or redefinitions while raising the importance level of organizational context and structure;
- The second mainstream focuses on the role of modeling and conceptual models of the innovation ecosystem;
- The third mainstream focuses on the framework concepts at different abstraction levels;
- The fourth follows the evaluation principles and techniques that established ecosystem metrics while enforcing sustainability;
- The fifth elaborates on domain-specific aspects of innovation ecosystem development through the institutionalized driving forces.

During the early 1990s, national innovation programs referenced innovations through a system concept. A system is an organized collection of elements that closely collaborate to achieve a mutually agreed set of goals. Engineering assumes a skilled movement through an unknown environment. Reference [3] describes systems engineering as a transdisciplinary approach to successful systems

development and operation where the term “*successful*” assumes systems that satisfy their stakeholder's needs. The term innovation ecosystem appeared in the early 2000s as a challenging shift toward meeting the emerging growth of knowledge-based approaches in economics, organizational sciences, research, development, industry, education, and engineering. The further justification of the innovation ecosystem paradigm, elaborated in [4], considers it a “*smart system*” explained by the characteristics of complex adaptive systems. It emerges from a deep understanding of the agents' dynamics, relationships, interactions, and results disseminated among social system layers (cultural, political, and economic). In [5], based on the comparison of selected references, the authors emphasize three newly introduced details concerning novel dimensions of future innovation positioning: the enlarged scope of innovation, the innovation-conductivity environment (ecosystems connected over a network), and different studies concerning ecosystems. Innovation ecosystems, as a metaphor for collaborative innovation networks, perfectly align with the 21st-century concept of co-creation networks. That is why the term innovation system demands an upgrade to an innovation ecosystem that better suits current and future effective worldwide policymaking. Engineering an innovation ecosystem roughly includes process and product dimensions. As a complex, dynamic, communication-based, discrete system (product), its building assumes a systematic, disciplined, and measurable process. In [6], the authors elaborate on an attempt to systematize stages and phases of ecosystem development as a contribution to framework-based approaches. They define the innovation ecosystem as a multidimensional business environment, a strategic macro-level social actor whose role is to catalyze or mediate all other heterogeneous stakeholders (actors). In [7], the author focuses on definitions, concepts, relationships, and boundaries as critical influencers. The elaboration suggests two general views of innovation ecosystem *structural* (multilateral collaboration subject's metaphor) and *affiliation* (a metaphor for macro-level interactions). Contemporary research and development activities elaborated on and discussed in [8,9] have opened further refinements of innovation ecosystem fundamentals. The aspects of transformation from innovation systems to innovation ecosystems are discussed in [10]. The

systematization of tangible and intangible dimensions and the openness principle involvement have firmly influenced our approach to innovation ecosystem fundamentals modeling.

Considering the second research and development mainstream conceptual background references cluster over Helix models ranging from the initial triple (*university–industry–government relations*), through quadruple (*triple + media-and-culture-based public*), and to quintuple (*quadruple + natural environment*) Helix models, discussed in [11-15]. Model-driven development and model-driven software development are still challenging disciplines [16]. Combining generic modeling principles with different helix models has influenced the selection of an open, hyper-helix model as a foundation for innovation ecosystem model building.

The framework concept emerged from theoretical discussions and digital transformation aspects of sustainable innovation ecosystem development. Digital transformation of complex real-world systems is generally a business process transformation in an enterprise architecture context powered by the appropriate framework. A framework may be defined as a physical or conceptual foundation that supports or guides building a particular artifact or performing a particular activity. It is similar to a skeleton that gives shape, form, and strength to the basic structure of observed objects or phenomena. Framework favors reusability by managing overall control flow and orchestration of dynamically configured components in an inversion of control manner. According to the abstraction level, frameworks cluster into three main categories: conceptual, theoretical, and operational.

Theoretical frameworks encapsulate a single formal theory as a context in which underlining domain understanding is gained and investigated. Conceptual frameworks are analytical tools focused on the segregation of concepts and ideas that, entirely or partially, integrate one or more formal theories with other related concepts and heuristics. Operational frameworks are digital twins of either or both of their counterparts. The representative references dominantly address theoretical and conceptual innovation ecosystem frameworks. In [17], the authors elaborate on an open systems model adapted as a framework powered by

extensibility features. In [18], the author presents and discusses several software aspects of innovation frameworks. The sustainability aspects of conceptual framework development and its foundation in innovation ecosystem standardization have been the focus of [19] elaboration. In [20], the author introduces an orchestrating ecosystem through the multi-layered framework. The institution-developed approach to the conceptual framework, examining the impacts of innovation ecosystems, and formulation on the national level has been the focus of [21]. In [22], the author introduces the foundations of an information ecology theory as the theoretical framework for digital innovation ecosystems. The authors put particular emphasis on answering the following two main questions. How are the efforts of autonomous actors embedded in the ecosystem's architecture integrated into a coherent whole? What role do digital technologies play in this integration? The authors claim that the presented theory can inspire the development of next-generation information systems for ecosystems as a new organizational form. In [23], the authors formulate a circular model of four main mechanisms that drive ecosystem transformations through disruptive innovations as an ordered set (*transformation forces, opportunity identification, value alignment, and revitalization*). In the concluding section, the authors raise four groups of challenging questions. The first group addresses ecosystem transformation forces/changes, among which the inclusion of novel technologies, like Artificial Intelligence and Blockchain, seems promising. The second group introduces ecosystem opportunity identification and its impact on ecosystem transformations (actors' role and position change, new strategies and substitutes, and disruptive technology changes). In the ecosystem value alignment phase, the authors claim that the orchestration foundation and orchestrators' directing abilities are crucial too. The final challenging group focuses on ecosystem revitalization aspects. The main focus is on how the new capabilities appear in the ecosystem context and influence its transformation. Considering the complete framework elaboration the presented vision is an example of an operational category. The lack of published work on the operational framework category justifies our approach to software-empowered innovation ecosystem framework specification and development. The analytical



framework for comparison and evaluation of different innovation strategies is the main topic of [24] elaboration. The analytical framework runs on simple rules and a four-dimensional model (*objectives, scope, advantages, and flaws*). The generic approach to complexity visualization and reduction, supported by a software framework [25], drives and directs our approach to its incorporation, as a plug-in, in the future innovation ecosystem software framework.

Domain-specific aspects of innovation ecosystem formulation and development are the mainstream in published literature. The main reason for such a situation is the long-lasting domination of structural vs. behavioral aspects of innovation ecosystem architecture specification. The recent publications elaborate on actors that are the building blocks of the innovation ecosystem architecture and direct its behavior. In [26], the authors present a sublimating discussion on joint forces to “*create value*”, as a fundamental goal of any organizational system. In [27], open innovations concepts are re-discussed and revitalized. In [28], the authors elaborate on the open hub concepts in transforming fundamental principles of propriety-based innovations. In [29], the authors address industrial endeavors, while [30] focuses on a so-called forgotten sector (innovation medium and low technology sectors). In [31], the authors address small and medium size enterprises' role in India's innovation ecosystem context, while [32] elaborates on inter-firm knowledge transfer as an innovation incubating force. In [33], the authors focus on Big Science organizations' role in innovation ecosystem architecture. The essential impact of high education is elaborated in [34,35], while Smart knowledge management is at the core of [36] content.

The most influencing mainstream, the digital transformation towards software-supported interoperability innovation ecosystem framework, is currently inadequately elaborated. In a software framework-empowered innovation ecosystem, the mainstream challenges are the interoperability paradigm and the information technologies that support it.

### III. THE INNOVATION ECOSYSTEM DRIVERS

The main origins of all innovations (Fig. 1) are learning (formal, non-formal, and informal) and performing (education, teaching, training,

researching, practicing, meditating, specifying, and generally doing). The interoperability of future innovation ecosystem actors' strategies assumes the forward-looking approach accenting the methods and techniques that would appear and closely collaborate or cooperate. Future interoperability addresses past, current, and future heterogeneous component integration in an interoperable manner.

Learning refers to an intellectual process of acquiring knowledge, skills, values, and virtues, through experience, study, or education. It is inherently informal and may, consciously or unconsciously, occur through education, personal improvement, schooling, training, or experience. Education is a process-oriented, well-structured, and formal approach to learning. Change is the root of all learners, learning is the root of all changes, and changes are the driving forces of all innovations (Fig. 1).

This blending and reflexive context incrementally builds an actor's mindset (collective or individual) and improves the overall cognitive abilities. For the quite long time, all the relevant innovation influencers (researchers, educators, policymakers, and business leaders) struggled over knowledge and skills compliance with the overall work processes mantra. At the same time, knowledge is rapidly expanding. Technologies and work processes are dramatically changing and demanding more sophisticated skills. Education and learning disciplines, as they are inherently inert but rational in their very nature, desperately need a lifelong foundation. The embedded timeline splits into appropriate segments (stages or states) that usually appear like marathons rather than sprints. They need a fundamentally new global approach compliant with the Science of Learning and Development

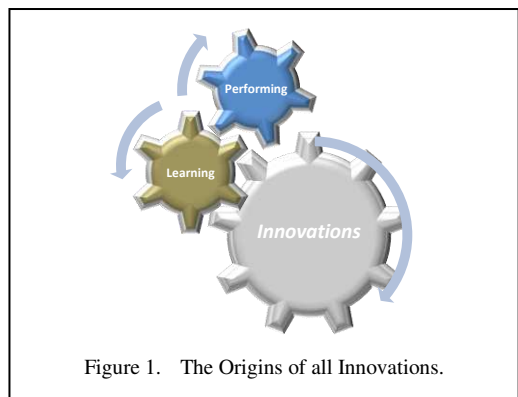

Figure 1. The Origins of all Innovations.

(SoLD) principles and practices. The result is a cooperative and collaborative education, learning, and performing ecosystem that is the foundation for an innovation-based society.

#### IV. THE DIGITAL TWIN - A SOFTWARE FRAMEWORK MODEL

Digital transformation of complex real-world systems is generally a business process transformation in an enterprise architecture context powered by the appropriate framework. Artificial intelligence (AI) applications and massive dataset-handling technologies radically change the digital transformation process, methods, and tools. The multidisciplinary and interdisciplinary study contents, better aligned to the society's well-being and sustainability, appear as a must. It assumes total support framework openness and collaboration between all relevant actors of the entire social community. Creating a digital twin is a contemporary modeling strategy for the sustainable transformation of complex, operational, real-world systems into a collaborative network of all relevant actors (stakeholders). The process of engineering System-of-systems addresses these aspects from theoretical and practical angles. The inherent complexity of such an endeavor assumes raising the level of abstraction and suppressing all underlining details until relevant context-dependent information or data is available upon the elicitation and analysis activities. The hyper-framework modeling paradigm delegates the final decision on the concrete platforms or technologies until appropriate.

Fig. 2. presents The Generic Ontology Meta Model of the system of systems abstraction. It represents a static meta-structure of an arbitrary complex actor in the innovation ecosystem framework model.

Two-folded composite mechanisms, defined by the *InternalTopology* and the *ExternalCollaboration* associative meta-classes, enable the creation of hyper-structures as the main characteristic of the collaborative systems model. The role of the rest of the meta-classes is straightforward regarding the naming convention used in the above ontology model.

Fig. 3 presents a multilevel and multidimensional meta-model of framework-

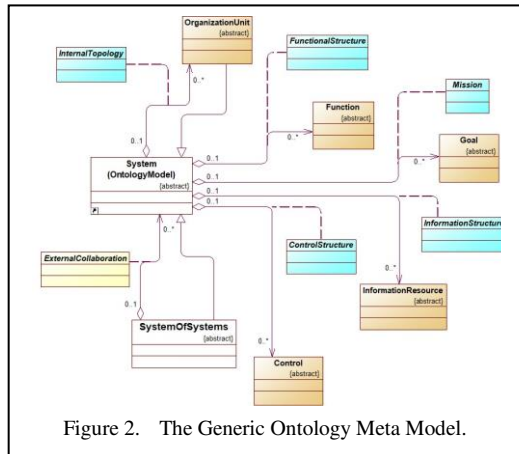

Figure 2. The Generic Ontology Meta Model.

handled dimensions. The innovation ecosystem abstraction aggregates the collection of Dimension abstractions over an associative meta-class designated as the *Configuration*. The crucial association enabling multi-level representations of arbitrary dimension represents a recursive aggregation supported by the *InternalStructure* associative meta-class and the *ExternalLinking* interface. The Dimension abstract meta-class specializations declare an open set of main meta-class groups with different tangibility levels. They range from highly tangible (Actors, Capital, and Infrastructure) to mostly intangible (Ideas and Knowledge) and context-tangible (Regulations, Interfaces, Culture, and ArchitecturalPrinciple).

The highest abstraction level assumes the enterprise architecture (EA) modeling approach. Fig. 4 presents a starting model of the highest abstraction granularity level actors participating in the innovation ecosystem integration model. Each actor is an abstract entity capable of storing, processing, servicing related users, and

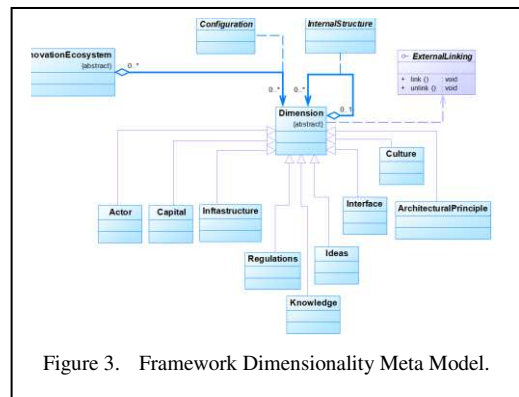

Figure 3. Framework Dimensionality Meta Model.



- introduction, *Historical Social Research*, 40(3), 7-29.
- [3] *Guide to the Systems Engineering Body of Knowledge (SEBoK)*, version 2.7, [https://www.sebokwiki.org/wiki/Guide\\_to\\_the\\_Systems\\_Engineering\\_Body\\_of\\_Knowledge\\_\(SEBoK\)](https://www.sebokwiki.org/wiki/Guide_to_the_Systems_Engineering_Body_of_Knowledge_(SEBoK)), Accessed on 23 November 2022.
- [4] Jucevičius, G. & Grumadaite, K. (2014). Smart development of innovation ecosystem, 19<sup>th</sup> International Scientific Conference; Economics and Management 2014, ICEM 2014, 23-25 April 2014, Riga, Latvia. *Procedia - Social and Behavioral Sciences*. 156(2014), 125 – 129.
- [5] Smorodinskaya, N., Russell, M. G., Katukov, D. & Still, K. (2017). Innovation Ecosystems vs. Innovation Systems in Terms of Collaboration and Co-creation of Value, *In the Proceedings of the 50<sup>th</sup> Hawaii International Conference on System Science*.
- [6] Rabelo, J. R. & Bernus, P. (2015). A Holistic Model of Building Innovation Ecosystems, *IFAC-PapersOnLine*. 48(3), 2250-2257.
- [7] Adner, R. (2016). Ecosystem as Structure. *Journal of Management*.
- [8] Granstrand, O. & Holgersson, M. (2020). Innovation ecosystems: A conceptual review and a new definition. *Technovation*, 90–91, 102098.
- [9] Fischer, B., Gomes, L., Bernardes, R.C. & Facin, K.(2022). Guest editorial Innovation ecosystems: new perspectives and the way forward. *Innovation & Management Review*, 19(1), 2-11.
- [10] Xiaoran, Z. & Cai, Y. (2022). Transforming Innovation Systems into Innovation Ecosystems: The Role of Public Policy. *Sustainability*, 14(12), 7520.
- [11] Carayannis, E. G. & Campbell, D. F. J. (2010). Triple Helix, Quadruple Helix and Quintuple Helix and How Do Knowledge, Innovation and the Environment Relate To Each Other?: A Proposed Framework for a Trans-disciplinary Analysis of Sustainable Development and Social Ecology. *International Journal of Social Ecology and Sustainable Development (IJSESD)*, 1(1), 41-69.
- [12] Etzkowitz, H. & Leydesdorff, L. (2000). The dynamics of innovation: from National Systems and “Mode 2” to a Triple Helix of university–industry–government relations, *Research Policy*, 29(2), 109-123.
- [13] Raimondi, F., Comon, P., Michel, O. & Spagnolini, U. (2017). Multidimensional factorization through helical mapping. *Signal Processing*, 131, 171-180.
- [14] Jonas, K., Lech, S. & Colin, D. (2020). Helix Models of Innovation and Sustainable Development Goals, In: Leal Filho, Walter Azul, Anabela Marisa Brandli, Luciana Lange Salvia, Amanda Wall, Tony (Ed.): *Industry, Innovation and Infrastructure. Encyclopedia of the UN Sustainable Development Goals*, Springer, Berlin, Heidelberg, (pp. 1-15).
- [15] Chekanov, A. (2022). The Triple Helix in transition economies and Skolkovo: a Russian innovation ecosystem case. *Journal of Evolutionary Studies in Business*, 7(2), 160-183.
- [16] Perisic, B. (2014). Model Driven Software Development – State of The Art and Perspectives (Invited paper), *In Proceedings of INFOTEH-JAHORINA Vol. 13, March 2014*. (pp. 1237-1248).
- [17] Wallner, T. & Menrad, M. (2011). Extending the Innovation Ecosystem Framework, <https://www.researchgate.net/publication/268006642>, Accessed on November 17 2022.
- [18] Bulgacs, S. (2013). The first phase of creating a standardized international innovative technological implementation framework/software application. *International Journal of Business and Systems Research*, 7(3), 250.
- [19] Zheng, L. & Stephens, V. (2019). Exploring Innovation Ecosystem from the Perspective of Sustainability: Towards a Conceptual Framework. *Journal of Open Innovation: Technology, Market, and Complexity* 5,(3) 48.
- [20] Autio, E. (2022). Orchestrating ecosystems: a multi-layered framework. *Innovation*, 24(1), 96-109.
- [21] Laasonen, V., Nyman, J., Fornaro, P., Lähteenmäki-Smith, K., Kolehmainen, J., Koski, H. & Ranta, T. (2021). Impacts and indicators of Innovation Ecosystems A Framework for Analysis, In *Finnish Government publications of the government's analysis, assessment and research activities* 23 (pp. 69-74).
- [22] Ping, W. (2021). Connecting the Parts with the Whole: Toward an Information Ecology Theory of Digital Innovation Ecosystems. *MIS Quarterly*, 45(1), 397-422.
- [23] Oghazi, P., Parida, V., Wincent, J. & Rana Mostaghel, R. (2022). Ecosystems transformation through disruptive innovation: A definition, framework and outline for future research. *Journal of Business Research*, 147, 16-26.
- [24] Sheth, A. & Sinfield, J. V. (2022). An analytical framework to compare innovation strategies and identify simple rules. *Technovation*, 115, 102534.
- [25] Perišić, A. & Periši, B.(2022). The Foundation for Open Component Analysis: A System of Systems Hyper Framework Model. In *Advances in Principal Component Analysis*, edited by Fausto Márquez. London: Intech Open, 2022.
- [26] Pushpanathan, G. & Elmquist, M. (2022). Joining forces to create value: The emergence of an innovation ecosystem. *Technovation*, 115, 102453.
- [27] Wikhamn, R. B. & Styhre, A. (2022). Open innovation ecosystem organizing from a process view: a longitudinal study in the making of an innovation hub. *R&D Management*.
- [28] Alam, M. A., Rooney, D. & Taylor, M. (2022). From ego-systems to open innovation ecosystems: A process model of inter-firm openness. *Journal of Product Innovation Management*, 39, 177– 201.
- [29] Xiaohua, Y., Qi, Y., Yu, L. & He, Y. (2022). Temporal and Spatial Evolution of Coupling Coordination Degree of Industrial Innovation Ecosystem—From the Perspective of Green Transformation. *Sustainability* 14,(7) 4111.
- [30] Muhammad, N., Yunis, M . S., Atiq, M., Owais Mufti, O. & Qadus, A. (2022). The 'Forgotten Sector': An Integrative Framework for Future Research on Low- and Medium-Technology Innovation. *Sustainability* 14(6), 3572.

- [31] Rakshit, S., Islam, N., Mondal, S. & Paul, T. (2022). Influence of blockchain technology in SME internationalization: Evidence from high-tech SMEs in India. *Technovation*, 115, 102518.
- [32] Majuri, M. (2022). Inter-firm knowledge transfer in R&D project networks: A multiple case study. *Technovation*, 115, 102475.
- [33] Li-Ying, J., Sofka, W., & Tuertscher, P. (2022). Managing innovation ecosystems around Big Science Organizations. *Technovation*, 116, 102523.
- [34] Cai, Y., Ma, J., & Chen, Q. (2020). Higher Education in Innovation Ecosystems. *Sustainability*, 12(11): 4376.
- [35] Taxt, R. E., Douglas K. R., Robinson, A. S. & Arnt Fløysand, A. (2022). The embedding of universities in innovation ecosystems: The case of marine research at the University of Bergen. *Norsk Geografisk Tidsskrift - Norwegian Journal of Geography*, 76(1), 42-60.
- [36] Magyari, J., Zavarkó, M., & Csedő, Z. (2022). Smart knowledge management driving green transformation: A comparative case study. *Smart Energy*, 7, 100085

# The Managerial Prerogative of Employer and Internal Labour Mobility: Where are the Boundaries?

Tijana Kovačević<sup>1</sup>

<sup>1</sup>Faculty of Law, University of Belgrade, Belgrade, Serbia

<sup>1</sup>tijanarkovacevic@gmail.com

**Abstract**—The managerial prerogative of an employer is manifested in the right of an employer to manage the work of employees on a daily basis. It implies that an employer determines in which way employees shall perform work by giving them specific working assignments. However, the content of work and duties that fall under a job description can only be tentatively stated in the employment contract. This is for the reason of an impossibility of foreseeing all the details related to the execution of the performance during the course of employment. Hence, the employment contract as a continuous contract places more emphasis on modifications related to terms and conditions of employment. Since changes can be made to the detriment of the weaker party in the employment relationship, it is necessary to ensure protection of employees while recognizing the right of employers to manage the company in order to achieve best business results.

**Keywords** - contract of employment, right to manage, internal labour mobility

## I. INTRODUCTION

The term “prerogative” is typically used with the meaning of a special right or privilege exclusively granted to a particular individual, class or establishment [1]. Also, it is defined as the power to make decisions or influence the behavior of others. For the first time, it was used in Roman law under the name *praerogativa*, which means the prior right [2]. Historically, in the decision-making process, holders of the right to vote, who belonged to a certain group, were the first to vote and, in that sense, were considered privileged [3]. Since they had preferential treatment they actually expressed their opinions before others, which made them

more important members of the society. As Kahn-Freund in his capital work noted, regardless of a type of society there will always be those who will have more social power [4]. Social power is defined as the capacity to assert control and give orders. It was very present between the master and the servant from which modern employment relationship was derived [5]. In that respect, the employee is subordinated to the employer who has the power to command.

The category of social power is inherent in the employment relationship where employers issue work assignments which employees should properly accomplish. Hence, at the heart of the employment contract lies the act of submission of one contracting party to another. It can be said that the employee’s duty to obey and the employer’s right to manage are two sides of the same coin. Thus, the employer’s right to manage arises from the relationship of subordination in which the employee acts under the authority of the employer. Hence, “not only does the contract of employment constitute the foundation of the employment relationship, but it also provides the legal basis for the employer’s right to manage an employee” [1].

Based on that premise, the employment contract is characterized as the prerogative contract, which reflects the power imbalance of the contractors. Alternatively, it is also described as a transaction between two qualitatively distinct parties, for the reason that the employee and the employer are legally and economically unequal subjects of law [6]. There are two main arguments that confirm this statement.

First, the employee-employer relationship is governed in accordance with the unilateral pre-determined terms and conditions of employment. If truth be told, the employee cannot influence the working conditions but may or may not accept the working conditions predetermined by the employer. [7]. Thus, the employer has the right to draft the employment contract, while the employee has the choice to sign off or give up on the job. The unequal negotiating power between the employer and the employee is considered to be the most significant characteristic of this type of contract [8].

In theory, the content of the contract of employment is determined by mutual consent of the employer and the employee, while in practice the interest of the employer prevails. Namely, the employee and the employer have different interests, since the employer wants to reduce costs and maximize profits, while the employee, on the other hand, wants more favorable working conditions and higher earnings. In connection with that, the ownership of capital as the basis of economic and social power provides the employer with the legal entitlement to dictate the terms of the employment contract [9]. Second, the contract of employment is a legal instrument under which the employee undertakes to perform work for the benefit of the employer follow its directives. Hence, by entering into an employment contract, the employee voluntarily waves part of his autonomy and submits himself to the authority of the employer [10].

## II. THE CONTENT OF THE MANAGERIAL PREROGATIVE OF EMPLOYER

From a theoretical standpoint, the managerial prerogative of employer is a legal concept which strives to explain the position of the employer in workplace governance. Actually, it represents the distribution of power within the workplace where the dominant position is taken by the employer who unilaterally makes decisions [11]. In a practical sense, the employer prerogative is reflected in the legitimacy to delegate work tasks and instructions for the performance of certain work.

Thus, managerial authority can be manifested in a number of ways. The first is exercising control over the personnel in order to gain more control over their work-related activities. Precisely, personal control entails that the employer issues work guidelines, organizes the work of employees by choosing time and place of work as well as determining the manner and

conditions of work performance [1,12]. To ensure the best possible organization of work the employer has the right to continuously manage their employees.

Beside that, employers are authorized to make decisions concerning the implementation of individual and general policies of the organization with the aim of gaining extra profit. Furthermore, employers make decisions regarding the dynamics of production, usage of tangible assets and the mode of performance in the market [13]. In fact, the activities of planning, organizing, coordinating and controlling the working environment are typical managerial activities exercised by the employer in the course of running a business. It means that an employer has the right to organize, manage, control and distribute the work in the enterprise. Indeed, without those functions the employer would not be able to successfully carry out his commercial activities [14].

On the other hand, the employee makes his work skills available to the employer in the production process [13]. In other words, after an employment relationship is created, the employee automatically becomes obliged to participate in the company's activities by performing his working duties [12,15]. This stems from the statement that both the employee and the employer are responsible for achieving economic goals. Consequently, employees are seen as a human capital that helps the organization to fulfil its business objectives. In light of that, it is important to prevent exploitation of the employees, but at the same time it is important to give the employer some amount of power in order to get the work done [16]. On the whole, protection of the employees from abuse of the employer's power has equal value for the employment relationship as providing the employer with the right to manage the company. "To state in right duty parlance, the employer must have the right to determine how his concern shall operate, what should be the optimal unit labour ratio that fits his enterprise, what should be the working environment of his enterprise and other decisions which incur costs and thus are a part of strategic decision making exercise" [14].

Moreover, the managerial right of an employer is a right by default, not guaranteed by the contract or law. In accordance with the freedom to conduct a business, the employer is free to organize his activities in the way he

considers most effective. Trying to find the best possible solution to earn profit and increase the value of the enterprise the employer is performing managerial functions, such as hiring, firing, leading, organizing and controlling [16]. Thus, the employer is empowered to direct employees, inputs, capital, equipment to fulfill the company's plans and target [17]. The managerial prerogative of employer is a broad category that covers all aspects of employment, which means that the employer has the right to transfer employees from one job to another or from one workplace to another [15].

In that sense, the employer is allowed to make some relevant changes within the working process. Of course, changes may be caused *inter alia* by the development of information and communications technologies, knowledge economy and global integration. Thus, whether to increase productivity or adhere to technological innovations, the employer may wish to introduce changes in the organization and performance of work [18]. But what happens when the employer wants to enhance or further their prerogative beyond the established ambit. There are several ways in which the employer can expand the boundaries of their authority. The most common way is to strengthen its bargaining power in the process of collective bargaining or to impose on employees unilaterally changed working conditions. In respect of that, Strydom concludes correctly that "where an employer cannot further its prerogative through collective bargaining or participative management, it may endeavour to achieve this by unilaterally changing the terms and conditions of employment of its employees in accordance with its aims" [1].

In one of the leading Asian cases, managerial prerogative is roughly defined as an unlimited right of the employer to select, transfer, promote, demote, dismiss and reemploy the employees according to his free judgment [19]. That is to say, the employer is authorized to determine any and all working conditions based on its business assessment. For this reason, by some accounts, the employer power is more entrenched than ever before, which raises the question of the denial of the employees rights at the workplace [20]. This position is taken because, in broad terms, employer's right to manage is limited by the principle of good faith and employee rights. In relation to that, a strong argument has been presented that strengthening of the managerial prerogative makes it more difficult for

employees to uphold their rights, which counteracts democratization [18].

This further means that the contract of employment as a product of consensus can only be changed in the same manner, by mutual assent of the employer and the employee [20]. Therefore, changes to the contract of employment should also be decided by both interested parties through their own discussions and dialogs [21]. However, consensual theory in labour law has been called into question due to the trend of expanding the employer authority in regard to contractual amendments while at the same time encouraging the employee mobility.

When it comes to labour mobility, we can differentiate two types of mobility: internal and external. However, the analysis in the present paper shall be limited only to internal labour mobility, both functional and geographical.

### III. IS THE TRANSFER OF EMPLOYEES EMPLOYER SPECIFIC PREROGATIVE?

The employer has the right to run his business and organize his workforce in the way he thinks appropriate to achieve business goals. In other words, in order to increase revenue the employer may vary content of work in relation to the changing demands of production. Also, the employer has the prerogative to transfer an employee from one job to another or from one place of work to another for the sake of production maximization. With the purpose of giving deep insight into the complex nature of the employer prerogative to transfer employees within the same business establishment prominent legal theorist emphasize the fact that changes in working conditions must not affect the amount of wages earned by the employee [22].

Actually, some authors define transfer as "a lateral shift causing movement of individuals from one position to another usually without involving marked change in duties, responsibilities, skills needed or compensation" [23]. There are both positive and negative aspects of internal transfers. For instance, the positive aspect is that internal transfers can offer employees new opportunities and the potential to learn new skills and gain new experiences. For employers, transfers provide the ability to move employees into positions where they may be more successful and productive [24].



Moreover, the managerial right of employer cannot be exercised in a way that employees suffer losses of their guaranteed level of legal protection. Simply stated, achieved employees' rights must be maintained in case of transfer within the enterprise. That is to say the employer has a legal entitlement to transfer the employee from one office to another as a part of his right to organize his business provided that earned income, benefits or other privileges are preserved. In that matter, employee transfer is the process of horizontal movement of the employee, wherein there is a change in the job, without any changes or revision in the remuneration, pay and other financial benefits. Actually, it is a form of internal mobility, in which the employee is shifted from one job to another usually in a different location, department, or unit [24].

Besides horizontal labour mobility which is considered as a regular type of mobility there is also vertical labour mobility. To be precise vertical labour mobility is that in which there is the movement of labour from one occupation to another in the different grade or level. Hence, "occupational mobility can be lateral (within a broad class of jobs similar in socioeconomic status) or vertical (from one job to a better or worse job)" [25].

In the Spanish legal system, after the last reform implemented to promote internal flexibility, the employer prerogative to vary substantial contractual provisions has been significantly expanded. The regulatory framework has introduced a unique model of internal flexibility through which a signed agreement between the employer and the employee is more "adaptable" to the business needs and economic changes [26]. The Spanish system contemplates the existence of two types of functional mobility: the horizontal, also called ordinary to be the most common in companies, which is characterized by the change of activity of the worker within the same professional group, according to the decision of the management of the company [27]. It means that transfer occurs as a result of the employer unilateral decision and consists of assigning the employee tasks or functions different from those originally established in the employment contract [28].

In regard to vertical mobility or extraordinary mobility, contractual changes are permitted under certain conditions (notification of the modification, existence of justifying reason, the

dignity of the employee is not violated etc.). The problem here is that the changes are made by a unilateral decision of the employer and not through an annex, which casts doubt on the contractual nature of the employment relationship. In conclusion, depending on an employer's business decision, employees may be obligated to perform all functions corresponding to one professional group, or only some of them, or functions belonging to more than one professional group [29].

From a comparative perspective, the judicial practice (including Spanish employment courts) is inclined to implement the principle "solve et repete" in the labour law system. Actually, this principle has found its place in labor law in the context of reviewing the managerial prerogative of employer [27]. Namely, "solve et repete" is a Latin aphorism which can be understood as comply and then complain. Within the labour law, it would mean that the employee can question the validity of the employer's order only after he or she has acted on it. That being the case, the employee breaches her duty to obey when he or she questions the employer's decision on the occupational or geographical transfer. Thus, the employer's right to transfer employees and to assign them new and different tasks and the employee's corresponding duty to work stand out as the central legal issues [18].

The transfer of an employee is the most common reason for concluding an annex to an employment contract in Serbian law. The Serbian legislator assigns a broad meaning to the term relocation, which implies both functional and geographical mobility [30]. In any case, the transfer introduces changes in the existing work schedule in order to meet new needs and fulfill the interests of the working environment. Internal transfer can either be temporary or permanent depending on the decision of the organization and the conditions under which the transfer is made [31].

On the other hand, transfer on the grounds of harassment and discrimination is considered as a abusive employer practices since there are no real technical, structural or organizational need nor other objectively established reasons which make it necessary to change the terms of the contract. The change of the contract does not include the change of the parties to the contract. Changes to the terms of the employment contract, especially those ones which are essential as content of work or place of work is

related to the protection of labor interests. Taking that into consideration, in Serbian law the employer and the employee may change the content of the employment contract only through mutual agreement [32].

However, an exception exists only in the case of jobs that are urgent when the transfer is temporary for a maximum of 45 working days in a period of 12 months [32]. In this case temporarily transfer to another suitable job is based on the employer's unilateral decision. Hence, there is only one extraordinary situation when the employer may introduce changes in the contract unilaterally without offering an annex to the employee.

Thus, changes to the previously agreed working conditions shall be made in the form of an annex to the employment contract. In regard to the procedure for changing the employment contract the employer shall deliver to the employee with an annex of employment contract a written notice that contains the reasons for changing the employment contract, the time period in which the employee should take a stand whether to accept or not the offered annex and the legal consequences which may arise if the annex of the employment contract is rejected [33].

“Along with other basic principles, the principle of job stability is the one which concerns the performance of the contract, which implies that the latter's modification and termination may occur in cases clearly set out by the legislator” [34]. Further, the employer is obliged to explain to the employee in more detail what changes in the work process and organization are reason for offer the annex to the employment contract (e.g. increased volume of work, rational use of working capacity of the employee, change in the regulations on organization and systematization of workplaces). Pointing out the legal basis for concluding the annex to the employment contract is considered insufficient. Instead, it is necessary to state the specific reason why certain changes are needed [35]. Therefore, it is not enough that employer indicates in the annex that changes are made because of the “needs of the process of organization” rather different formulation shall be used with more precise wording [36]. Yet, the employer himself determines when it is necessary to transfer an employee from one job to another. In other words, the employer is the one who evaluates when the process and

organization of work requires changes in that sense. However, the reasons for the transfer must be real, i.e. they need to really exist and to be objective [37].

Furthermore, transfer to another place of work can only occur if the employer's activity is carried out in different locations. Consequently, the employee may be transferred to different organizational unit of the employer, branch, and representative office. Due to the specific nature of the employer's activity (such as construction, telecommunications, electricity distribution, traffic etc.) the employee may be transferred to another place of work with the same employer without his or her consent [38]. This is prescribed in order to prevent obstruction of the performance of business activity. It is important to emphasize that in this context it is irrelevant the distance between the old and new place of work.

On contrary, the second paragraph of the article 173 Labour Act regulates that in case of internal geographical mobility the distance from the place where the employee had worked to the place where he is transferred shall be less than 50 km [30]. Besides that, transportation shall be organized that enables timely arrival to work and return from work. In addition, compensation for transportation costs shall be provided in the amount of the price of a public transportation passenger ticket [31]. Hence, an employee may be transferred to another place of work in the cases not prepecified only after his consent. However, the Serbian legislator failed to clarify whether these conditions are alternatively or cumulatively set. Instead, used terminology leads to the conclusion that the second exception applies to all employers and not only to those who perform specific activities.

Similar to Serbian law, in Romanian labour legislation as an exception, unilateral modification of the individual employment contract is possible only in the cases and under the conditions presented in the Labour Code. Moreover, changes may affect the essential elements of the employment contract, such as type of work and place of work [34].

#### IV. LIMITATIONS OF AN EMPLOYER'S *IUS VARIANDI*

At a time when the global economy is in a downturn companies often use structural adjustments, layoffs, and the employment contract amendments to reduce costs or tide over

difficulties [38]. Therefore, employers may change the originally established working conditions in order to ensure the survival of the enterprise. Consequently, the flexible adjustment of the contract to the circumstances that have changed is particularly important in this case. However, the managerial prerogative of employer must be subjected to legal limitations.

In principle, two approaches are possible. One that allows the employer to make unilateral changes under certain conditions, and the other that prohibits it. Changing the essential elements of the employment contract by the employer is banned in Serbian law. On the contrary, the consent of the employee and the employer represent condition sine qua non for changing the basic obligations from the employment contract. On the other hand, the employer has the power to vary working conditions which is not considered as a modification of the employment contract despite the fact that changes have an effect on its non-essential elements [31].

In connection with that, modification of the contract do not exist if the employee is requested to perform tasks which are related to the tasks that he or she regularly performs. The same counts for the temporary changing in the form and modality of the provision of work. It is noted that changing the job by modifying the job description does not constitute a change of employment contract unless the nature of the work performed changes. In that sense, the employer power to order transfers is denied since changes to the workplace and work content are all changes to the contract, which require the express consent of the worker before they can take effect. Finally, only permanent modifications of the essential elements of the contract shall be considered employment contract modifications, while modifications of the working conditions outside of the essential elements of the contract are regarded as an expression of an employer's *ius variandi* [33].

In Spanish law, quite reverse, *ius varianti* is used to denote "a breach of consensus in an employment contract" which allows the stronger contracting party, within the limits set by law, to unilaterally change the contract [28,38]. Although the terminology is different, the problems are essentially the same, and such problems have become increasingly prominent in the context of the current global economic crisis. Nevertheless, *ius variandi* is subject to limitations which are reflected in the

socioeconomic requirements and morality. Namely, the nature of the change must be such that it does not harm or imperil honor, safeness, dignity, interests or minimum rights of employees [38]. For instance, if transfer is not reasonable and necessary in terms of business, or if it brings serious disadvantages to the employee's life, it will be deemed invalid. Therefore, the decisions made by the employer in course of its *ius variandi* shall be build on a rational basis and indicated with the objective business needs [39].

In order for the employer to unilaterally change the employment contract, it is necessary that the test of proportionality is applied. Moreover, for the validity of unilateral changes to the employment contract, the principle of progression is developed alongside the proportionality test. Abovementioned principle prohibits leaving the minimum threshold of guaranteed rights. In short, the application of the principle of progression means the prohibition of business policies or measures that threaten acquired social rights. Taken together, the employer can not arbitrarily and capriciously determine the existence of grounds for changing essential elements of the employment contract [27].

Also, changes to the employment contract must not be such as to cause material or non-material damage to the employee [28]. Material damage is reflected in wage reduction or transportation costs increase, while non-material damage is manifested in diminution of free time [27]. It is important to mention that the conditions are set cumulatively, so the absence of one of them is considered abusive *ius varianti*.

## V. CONCLUSION

In recent years, the concept and scope of the employer's management authority has become the subject of analysis by numerous experts. This is due to the fact that economic changes has been affecting the mode of business operation. In connection with that, internal labour mobility has become an increasingly common phenomenon as a source of gaining competitive advantage. There are two types of internal labour mobility which are interrelated since the employee may move to a different role, a different location, or both while remaining employed by the same employer. As described above, the functional mobility is ability of the employer to assign different tasks or functions to the employee in comparison to

work content previously stated in the employment contract.

Additionally, in situations where the execution of the contract extends over time the elements of the contract must be flexible and adaptable. Since the employment relationship is continuous in its nature the existing obligations may no longer correspond to the interest of at least one contractual party. Thus, at the time of concluding the employment contract, it is not possible to determine ab initio the exact development of the planned activities. Therefore, the employment contract as a continuous contract places more emphasis on contractual modification. In regard to contractual modifications two main issues arise that is limitation of the employer's right to change the employment contract within a reasonable and fair boundary and finding the proper balance between the employer's right to manage and the protection of employee's rights.

#### REFERENCES

- [1] Strydom Louise, M. E. (1997). *Employer prerogative from a labour law perspective*. Doctoral dissertation. South Africa: Prof Pak le Roux.
- [2] Garner, A. B. (Ed.) (2009). *Black's Law Dictionary*. USA: West.
- [3] Reddy, P. K. (2014). Limitations upon managerial prerogatives under Industrial Disputes Act, 1947. *International Journal of Law and Legal Jurisprudence Studies*, 6(1), 1-19.
- [4] Davies, P., & Freedland, M. (1983). *Kahn-Freund's Labour and the Law*. London: Stevens & Sons.
- [5] Young Nayak, S. (2015). Revising the roles of master and servant: A theory of work law. *Pennsylvania Journal of Business Law*, 17(4), 1223-1255.
- [6] Baudry, B. & Chassagnon V. (2018). The Analysis of Employment Relationship in Contract Economic Theories: A Critical Review Based on the Nature of American and French Labor Laws. Available at: <https://journals.openedition.org/ei/6127>.
- [7] Kovačević, Lj. (2013). *Legal subordination in the employment relationship and its limitations [Pravna subordinacija u radnom odnosu i njene granice]*. Pravni fakultet, Univerzitet u Beogradu
- [8] Orakwue, E., Adeafie-Gyambrah N., Hammond Kweku A. (2006) Employment relationship and management control of labour process. *Journal of Business and Retail Management Research*, 1(1), 14-27.
- [9] Davies, L. C. A. (2015). *Employment Law*. Great Britain: Pearson Education Limited.
- [10] Collins, H. & Ewing, D. K. (2012). *Labour Law*. New York: Cambridge University Press.
- [11] Racabi, G. (2021) Abolish The Employer Prerogative, Unleash work law. Available at: [https://papers.ssrn.com/sol3/papers.cfm?abstract\\_id=3800910](https://papers.ssrn.com/sol3/papers.cfm?abstract_id=3800910)
- [12] Shooter, R.C. (2010) Managerial prerogative: a cosseted preserve of our labour system or a fool's safe haven? *SA Mercantile Law Journal*. 22(4), 532-558.
- [13] Barnard, C. (2004). Reconsidering the Mechanism to Regulate Working Conditions in the Light of Diversified and Individualised Employees and the Declining Labour Unions In *The Mechanism for Establishing and Changing Conditions of Employment/The Scope of Labor Law and the Notion of Employees* (pp. 51-58)
- [14] Jain, T. (2005). Employer's prerogative to change conditions of service: how far regulated? Available at: <https://www.researchgate.net/publication/228226271>
- [15] Clapp, A. R. (1953) Management's Prerogatives vs. Labor's Rights, *Case Western Reserve Law Review*, 4(2), 169-179.
- [16] Kovačević, Lj. (2021). *Establishment of an employment relationship [Zasnivanje radnog odnosa]*. Pravni fakultet, Univerzitet u Beogradu
- [17] Kanamugire, C. J. (2014). The Concept of Managerial Prerogative in South African Labour Law. *Mediterranean Journal of Social Sciences*, 5(20), 424-437
- [18] Rönmar, M. (2004). The managerial prerogative and the employee's duty to work: a comparative study of functional flexibility in working life, *The International Journal of Human Resource Management*, 15(3), 451-458
- [19] Shahrilnizam, M., Balakrishnan, P., & Murshamsul, M. K. (2015). Employer's Managerial Prerogative Right: An Evaluation of its Relevancy to the Employer-Employee Relationship, *Social Sciences & Humanities*, 23(5), 227-238
- [20] Kiss, G. (2018) Transition of a Contract of Employment: from the *Locatio Conductio* to the *Relational Contract*. *New Zealand Journal of Employment Relations*, 43(3), 75-90
- [21] Tintić N. (1972). *Labour and social law. First book: Labour relations (II) [Radno i socijalno pravo. Knjiga prva: radni odnosi (II)]*, Narodne novine, Zagreb
- [22] Sales, O. E. Management Prerogatives and Employees' Rights (A General Overview). (2002). *Business & Economics Review*, 13(1), 1-20
- [23] Yoder, D. (1958). *Handbook of personnel management and labor relations*. New York: McGraw-Hill
- [24] Nejad, B. A., Khyareh, M. & M. Firoozjaei, A. B. (2021). Interactions of Entrepreneurship, Economic Growth and Employment in Developing Countries. In *Proceedings of the 4<sup>th</sup> Virtual International Conference Path to a Knowledge Society - Managing Risks and Innovation - PaKSoM 2022* (pp. 493-494)
- [25] Long, J. & Ferrie, J. Labour Mobility. Available at: <https://faculty.wcas.northwestern.edu/fe2r/papers/Labour%20Mobility.pdf>
- [26] Lara S. C. (2012). Medidas de flexibilidad interna: movilidad funcional, geográfica y modificaciones sustanciales de condiciones de trabajo. *Temas Laborales*, 11(5), 221-248
- [27] Castro Pacheco, L. H. (2016). El Derecho de resistencia como mecanismo de control ante el uso desmedido o abuso del ius variandi. Available at: <https://dspace.unitru.edu.pe/handle/UNITRU/5873>

- [28] Guzmán, V. K. (2011) Ejercicio del ius variandi: aplicación, límites y efectos. Available at: [https://repositorio.uchile.cl/bitstream/handle/2250/111615/de-Velasquez\\_k.pdf?sequence=1](https://repositorio.uchile.cl/bitstream/handle/2250/111615/de-Velasquez_k.pdf?sequence=1)
- [29] Gíron Ramos, B. Á. (2002). Casos-Guía de laboral individual: Principose de derecho laboral y jus variandi. Universidad de la Sabana, Facultad de derecho, Shía, Puente del Común
- [30] Lazarević, A. (2015). *Amendments to employment contract - key legal aspects* [Izmene ugovora o radu – ključna pravna pitanja], preddoktorski rad (neobjavljen), Pravni fakultet, Univerzitet u Beogradu
- [31] Kovačević, Lj. (2016). *Valid reasons for termination of the employment contract* [Valjani razlozi za otkaz ugovora o radu], Pravni fakultet, Univerziteta u Beogradu
- [32] Dimitrijević, S. (2014). Amendments to employment contract [Izmjena ugovora o radu], *Pravo i privreda*, 1(3), 59-72
- [33] Kovačević, Lj. (2015). Legal consequences of referring an offer to amend elements of an employment contract with a focus on employee relocation or transfer to another job [Pravne posledice upućivanja ponude za izmenu elemenata ugovora o radu, sa posebnim osvrtom na premeštaj zaposlenog]. *Pravo i privreda* 4(6), 823-850
- [34] Nicolescu, A. (2021). Implications of modifying individual employment contracts in the light of current Romanian legal provisions. *Revue des Sciences Politiques*, 70, 56-65
- [35] Perić Kovačević, S. (2015). Annex to the employment contract – changes of working conditions [Aneks ugovora o radu – Izmjena ugovorenih uslova rada], *Pravo i privreda*, 7(9), 358-371
- [36] Živković, B. 2006. Employment contract and amendments to employment contract [Ugovor o radu i izmena ugovora o radu], *Pravna praksa*, 10, 4-15
- [37] Wilfredo Soria, Y. S. W. B. (2019). El ius variandi como potestad facultativa del empleador y los criterios de razonabilidad en los trabajadores de las empresas del sector privado, Universidad Andina del Cusco Facultad de derecho y ciencia política escuela profesional de derecho, Perú
- [38] Araki, T. (2004). The System of Regulating the Terms and Conditions of Employment in Japan, In *The Mechanism for Establishing and Changing Conditions of Employment/The Scope of Labor Law and the Notion of Employees* (pp. 3-20).
- [39] Castillo Alameda, T. M., & Agudo Blázquez, M. E., Modificación sustancial de condiciones de trabajo: un análisis retrospectivo. *Trabajo y derecho*, 14, 25-49

# Risk Management during Storing of Hazardous Substances

Goran Tepić<sup>1</sup>, Nina Ivanović<sup>2</sup>, Mihaela Tarakčija<sup>3</sup>

<sup>1,2,3</sup>University of Novi Sad, Faculty of Technical Science, Novi Sad, Serbia

<sup>1</sup>gtepic@uns.ac.rs, <sup>2</sup>nina.ivanovic.ace@gmail.com, <sup>3</sup>mihaela.tarakcija01@gmail.com

**Abstract**—The paper shows the classes of dangerous substances as well as the accidental events that occur during their storage. According to the literature, VCE is the main hazard in industrial complexes where an enormous amount of flammable substances are stored (e.g. hydrocarbons). The storage capacities of the process industry are integral units of the logistics system of hazardous substances and represent an inevitability in the normal development of production processes. Storage capacities have the role of compensating for spatial and temporal inconsistencies between delivered raw materials and spatial capacities, that is, final products and market requirements in the hazardous substances system. The storage of hazardous substances is classified as a high-risk logistics operation, the capacity of which can be the source of major accidents.

**Keywords** – risk, hazardous substances, VCE, organization and management

## I. INTRODUCTION

Depending on the type and their class (Fig.1), hazardous substances can belong to different production and logistics systems. There are frequent cases when one type of hazardous substance passes from one system to another, as well as through several subsystems within one system (e.g. transport, storage and distribution within the logistics system). Although the majority of hazardous substances are in the form of substances, those hazardous materials that manifest through the physical field in the form of radiation (radioactivity, electromagnetic field, etc.) should not be neglected. When these facts are taken into account, as well as the pursuit of new technologies, the constant increase in hazardous substances becomes inevitable. The layman's









Class	Type	Hazard subclass	GHS
1	Explosive	1	
		2	
		3	
		4	
		5	
		6	
2	Poisons and gases	1	
		2	
		3	
3	Flammable liquids	-	
4	Flammable solids, Self igniting substances	1	
		2	
		3	
5	Oxidizing substances and organic peroxides	1	
		2	
6	Toxic substances and infectious substances	1	
		2	
7	Radioactive	-	
8	Corrosive	-	
9	Various dangerous substances	-	

Figure 1. Classes of hazardous substances.

understanding that modern innovations bring clean (green) technologies is contradicted by the fact that the number of dangerous substances is increasing day by day. Modern innovations only shift the focus of application of dangerous substances from the sphere of substances to the physical field, thus creating the illusion that new

technologies contribute to the reduction of hazards.

Risk is a measurable hazard parameter to which a process or phenomenon is exposed. Risk is not a physical quantity, but an abstract concept that unites the threat, the probability of the occurrence of an undesirable event (uncertainty), vulnerability, exposure and consequences. Considering that risk unites different physical categories, it cannot be a classic physical quantity by its nature. Threat, uncertainty, vulnerability, exposure and consequences are different categories related to the hazard of an event and if the risk were a physical quantity, these parameters would require special scales for implementation in the form of risk.

However, if risk is viewed as an abstract concept, then the aforementioned risk factors (threat, uncertainty, vulnerability, exposure and consequences) can be simply multiplied and expressed in a normalized form via a risk matrix. The greatest difficulty in risk analysis is caused by the uncertainty of the occurrence of some events.

## II. STORAGE CAPACITIES

The storage capacities of the process industry are integral units of the logistics system of hazardous materials and represent an inevitability in the normal development of production processes. Storage capacities have the role of compensating for spatial and temporal inconsistencies between delivered raw materials and spatial capacities, that is, final products and market requirements in the hazardous materials system. The storage of hazardous materials is classified as a high-risk logistics operation, the capacity of which can be the source of major accidents. This fact is best illustrated by the fact that 17% of major accidents in the chemical industry were related to storage processes [1].

Fire is the most common cause of warehouse accidents, which, due to its escalating characteristics, easily spreads to a larger part of the warehouse complex, causing explosions, additional fires, gas clouds, etc. That is why storage capacities are very sensitive to the occurrence of domino effects, where fire is generally the initial event in the escalation process of an accident. This attitude is also justified by data from the National Fire Protection Association (NFPA), according to

which 13% of major fire accidents in the USA in 2009 occurred inside hazardous materials storage facilities, causing total losses of 69,98 billion \$. Statistical data clearly show that in the field of design, exploitation and maintenance of storage capacities there are considerable gaps that must be the subject of improvement in future research related to increasing safety working conditions.

The storage capacities of refinery complexes and chemical plants are intended for the storage of a huge amount of hazardous substances, the hazard class of which depends on the type of processing processes. Minor accidents of the storage capacity of large process complexes can lead to material damage that is measured in millions of dollars, while major accidents are accompanied by significant storage devaluation. Major accidents are most often characterized by a significant number of injured and dead, damage to buildings located in the immediate vicinity of the plant and endangering the environment, which, due to court rulings on compensation for damages, creates additional financial pressure on companies and can be the main cause of their bankruptcy. Since major warehouse accidents have been recorded in the past, many trade organizations and engineering associations have learned from this experience and over the past 60 years have made great efforts to define strict engineering guidelines and standards for design, operation management, maintenance, installation of safety systems and safety procedures, management of storage capacities within the chemical process industry complex. Current standards in the field of storage installations for hazardous materials in the USA are prescribed by leading institutions, such as:

- American Petroleum Institute – API,
- American Institute of Chemical Engineers – AIChE,
- American Society of Mechanical Engineers – ASME, and
- National Fire Protection Association – NFPA.

The standards and instructions prescribed by the mentioned organizations go beyond the national framework of the USA, because they served as a starting point for the legal regulation of the area of storage of hazardous materials in many countries around the world. Experiences built into such regulations have paid dearly for

huge human casualties and immeasurable material damage, and their purpose is to prevent accidents, especially those of a larger scale, through their compliance. The historical review of accidents enables classification according to the type of process complexes and storage installations for a certain class of hazardous materials, with the aim of valid categorization of the accident causes. Statistical processing of accident data is a much more complex task than it seems at first glance, because the basic issue of such a procedure is related to the relevance of the analyzed causes and the used sources of information, i.e. databases. The use of accident information from a larger number of sources certainly contributes to a better quality of the statistical sample, and this should be the basic guideline for the statistical analysis of all accidents, including those related to the storage of hazardous materials. Information that is used exclusively from one source is always accompanied by a certain degree of uncertainty about the validity of the statistical cause, especially if such databases are of a more national character (such as FACTS, MARS, ZEMA, etc.).

The first indicator of the poor quality of a statistical sample of a database is a relatively small number of data on a certain type of accident for a class of dangerous substances. The fact that some accidents with dangerous substances are not recorded in a database cannot be an excuse for researchers not to draw valid conclusions. Also, it should be borne in mind that the degree of accuracy of statistical analysis directly depends on the size of the statistical sample, because statistics work according to the law of large numbers. The historical review of accidents is only a necessary and not a sufficient condition for an adequate risk assessment in the hazardous materials system. The proof of this attitude is best illustrated by the large accidents involving hazardous materials that have occurred in the last few years.

### III. RISKS OF STORING HAZARDOUS SUBSTANCES

The basic direction in the systematic analysis of storage risks with hazardous substances includes a classified and categorized historical review of accidents. In this sense, a study that analyzes 242 process industry accidents in the period from 1960 to 2003, whose actors were storage tanks around the world [2], can be highlighted. The results of this

research show that 74% of accidents occurred in oil refineries, while fires and explosions were present in 85% of the considered cases. The main causes of these accidents were lightning strikes in 33% of cases, human factor errors due to inadequate handling and maintenance (30%), while the rest of the accidents were marked by equipment failures, sabotage, cracks and breaks in installations, static electricity, open flames, etc. The analysis of the considered accidents unequivocally showed the possibility of the absence of the majority of these accidents if adequate engineering procedures and procedures had been followed. The overview of storage capacity accidents is focused on tanks with dangerous substances [3]. In addition, Chang and Lin report that almost  $\frac{3}{4}$  of the accidents happened within refinery complexes, where the actors were storage tanks [2]. Common types of accidents that can occur with tanks containing hazardous substances include:

- Vapor Could Explosion – VCE and
- Boiling Liquid Expanding Vapor Explosions – BLEVE.

Accidental events that include the formation of toxic cloud, jet flame, fireball, fire flash and weak fire are mainly directly related to VCE and BLEVE accidents through a cause and effect. Individual occurrences of these events can represent potential accidents only if they are not causally or consequentially related to VCE and BLEVE effects (release of a toxic substance due to a valve leak or a weak fire with a small amount of spilled flammable liquid). However, it should be noted that a jet flame is an indication of a forced release of a flammable substance from a vessel (BLEVE) or stratified vapor cloud (VCE). A fireball occurs as a consequence of the escalation of accident events during the occurrence of BLEVE accidents with flammable substances and the ignition of an explosive mixture during the initiation of VCE. Based on this, it can be concluded that BLEVE and VCE are complex accidents, since their potential occurrence is coupled with the initiation and occurrence of several accidental events, such as the release of a flammable substance, the formation of a jet flame, fireball, etc.

### IV. VAPOR COULD EXPLOSION – VCE

Vapor Could Explosion – VCE (Fig 2.) is the main hazard in industrial complexes where enormous amounts of flammable substances





Figure 2. Illustrative presentation of VCE.

(hydrocarbons) are stored. During the last few decades, quite a number of these accidents have been recorded, which led to significant damage or complete destruction of industrial complexes, mostly in fuel storage facilities.

VCE are extremely complex phenomena with the nature of their origin not yet elucidated, and whose destructive potential depends on the affected combustible mass, cloud dispersion and reactivity of the gas mixture.

In order for VCE accidents to occur, the following conditions must be met:

- the spilled (discharged) substance must be flammable;
- there must be some ignition delay;
- the range of the vapor cloud must be of minimal size;
- hydrocarbon vapors with air must form a flammable mixture, that is, their concentrations must be within the upper and lower flammability limits, as well as
- necessary presence of turbulence.

In the context of the development of a gas cloud, special attention should be paid to the conditions under points b) and e). The necessity of a delay in ignition affects the generation of a larger amount of fuel vapor, and therefore the mass of the explosive (combustible) mixture, i.e. the gas cloud, is greater. Turbulence is necessary for the formation of an adequate mixture of vapor of the released substance and air, which is achieved by means of fuel jet discharge from installations and/or interaction of the gas cloud with obstacles that exist to contain it (walls, trees, buildings, etc.). The main components of the vapor cloud formed as a result of spilling gasoline include butane and

pentane, so their prominence in the explosive effect should not be ignored when assessing the risk and when it comes to a small degree of evaporation. The size, concentration and location of the gas cloud play a significant role in these parameters, which was evident in the example of an accident in 2009 in a large fuel storage facility (capacity of 110,000 m<sup>3</sup> for the storage of gasoline, kerosene and diesel) managed by the Indian Oil Corporation Jaipur [4]. The assessment of accidents of this type in order to identify the possible consequences of the explosion includes two steps:

- analysis of the first (initial) event in the form of an accidental spill of a flammable substance and
- modeling the processes that precede the emergence of VCE as an end-event.

The sequential development of events at the occurrence of a VCE accident includes the release of gasoline from the tank, filling of the pool with spilled contents within the tank embankment, continuous evaporation of the spilled substance, formation of a dense vapor cloud stratified at the ground, dispersion of the vapor cloud, ignition and its explosion. Releases of hazardous substances inside the HPI plant are in most cases of a limited nature, thanks to the presence of certain obstacles. The contours of the gas clouds are determined by the configuration of the installations, the depth of which varies in the range of 1-2 m. However, the release of petroleum products in open space, as well as in the case of storage terminal accidents, creates a cloud of hydrocarbon vapors that can cover a large area (in the example of the Jaipur accident, it was about 18 ha). Experiences from previous accidents show that gas clouds can move several kilometers in relation to the location of evaporation. The literature states that a fiery flash is a very likely accidental phenomenon that leads to an explosion in cases of delayed ignition of a vapor cloud [5].

The Jaipur accident was caused by the spill of 2116 t of gasoline containing 63.5% hexane and 36.5% pentane, at an ambient temperature of 30 °C, covering an area of 0.64 ha in an interval of 80 min [4]. The accident occurred as a result of a jet of gasoline from a damaged Hammer Blind valve, which caused a cloud of gasoline vapors weighing approximately 81 t, sufficient to cause an explosion equivalent to 38 t of TNT [4]. Research conducted by the

Independent Commission of Inquiry shows that the most likely source of igniting the gasoline vapor cloud and causing the explosion is fire-resistant electrical equipment or vehicle starting located in the immediate vicinity of the installations [6]. The Jaipur accident was marked by several specifics, and they concern the inadequately performed risk assessment and the appearance of white clouds that preceded the occurrence of powerful explosions. The previous authors report that the considered storage terminal is not significantly overloaded, and therefore it was not considered as a potential location for the occurrence of a vapor cloud explosion, nor was a more serious risk assessment performed. Another specificity of the accident is related to the appearance of white clouds at a low height from the ground. Most hydrocarbons in an accidental spill are initially cold and condensed, bearing in mind that such liquids are under pressure or in a cooled state. The state of hydrocarbons immediately after a release is similar to the behavior of a heavy gas, although at normal (atmospheric) pressure and temperature the released substance may be lighter than air. The reason for such a situation can be the result of three situations [7]:

- the initially low temperature of hydrocarbons leads to the condensation of fuel vapors (e.g. gasoline) that are trapped inside the droplets of the spilled substance under normal atmospheric conditions;
- vapors of spilled hydrocarbons in conditions of increased humidity affect their condensation, whereby they are trapped in the water mist, forming aerosols, and
- high density of spilled substance (hydrocarbons) regardless of weather conditions.

The conditions that lead to the formation of vapor clouds are most often a compilation of the above situations, among which the influence of increased air humidity should be highlighted. Aerosols formed from a mixture of hydrocarbon vapor and water mist manifest as a white cloud that reaches a relatively low height with stratified development near the ground. The vapor cloud formed under such conditions has a slow movement and rise, especially if the wind speed is low, which is a consequence of the

higher density of the gas cloud. This potential despite the loss from the so-called wastage. of cold gasoline results in the VCE effect [8]. In the general case, the immediate ignition of the gas cloud is manifested by a jet flame, a fiery flash or an ascending fireball leading to its dispersion. Sufficiently delayed and strong ignition initiates the occurrence of a VCE accident followed by a very powerful explosion with the potential to cause extensive damage. The basic elements that must be taken into account when analyzing accidents caused by the release of flammable substances include the analysis of similar accidents and incidents that occurred in the previous period, the implementation of risk assessment techniques with a focus on QRA methods, existing models and software packages for accident simulation, as well as an overview of previous research in this area. These elements on the example of the Jaipur accident show [4]:

- gasoline jet spillage is characterized by the development of vapor clouds of large dimensions and significant density at low altitudes;
- buildings and trees represent potential obstacles, so if they surround a flammable vapor cloud, the appearance of the VCE effect is quite certain, and
- transition from deflagration to detonation may occur, producing characteristically directional indicators.

The authors set as the main goal of this study the quantification of the potential overpressure caused by the VCE effect, using the PHAST 6.51 software, which is based on the PHA approach, and state that the maximum estimated overpressure is about 1 bar. For the sake of illustration, the overpressure of the shock wave of the explosion that causes the car to derail has values of (0.8-1.9) bar, while the destruction of buildings occurs at an overpressure in the range of (0.8-2.6) bar. According to the established consequences of the Jaipur accident, it can be stated that the overpressure of 1 bar, created during the VCE effect, was adequately assessed. Lessons that can be drawn from this accident include [4]:

- plants and installations with inherently high hazards should incorporate redundancy within safety systems and ensure their maintenance at all times;

- management must ensure the implementation of all identified procedures relevant to the process safety aspect of industrial capacity, and
- a high degree of operational competence, which is built on a combination of knowledge and experience, should be maintained at all times by all professional groups.

A similar type of accident occurred in 2005 at the Buncefield fuel depot (UK) when there was a strong explosion and significant damage to neighboring buildings due to the overflow of gasoline from the tank [9]. This accident had a prominent potential for the formation of a very large flammable vapor cloud, given the undetected prolonged spillage of gasoline. The Buncefield incident led to significant changes in the understanding of how an explosive cloud of vapor can form from overfilled large tanks designed to store highly volatile substances. Namely, the independent commission of inquiry under the auspices of the Health and Safety Executive (HSE) and the Environment Agency (EA) concludes in its report that the magnitude of the overpressure due to the explosive shock wave is much greater than the understanding of the VCE effect that occurs at that moment could predict [9]. In order to eliminate these doubts, a working group was formed, which states that the Buncefield accident could not have been predicted by applying any significant hazard assessment during fuel storage [10]. In particular, concerns were raised regarding the fact that the scale of the Buncefield accident exceeded expectations, which was due to errors in the interpretation of the way in which hazard identification and risk assessment was undertaken within the UK.

The assessment of the occurrence of a possible explosion in industrial plants accompanied by serious accidental hazards implies the application of the following regulations [9]:

- the Control of Major Accident Hazard Regulations – COMAH,
- planning (Hazardous Substance) Regulations – P<sub>(HS)</sub>R.

## V. ASSESSMENT AND IDENTIFICATION

The assessment of the occurrence of a possible explosion in industrial plants accompanied by serious accidental hazards

implies the application of the following regulations [8]:

- the Control of Major Accident Hazard Regulations – COMAH,
- planning (Hazardous Substance) Regulations – P<sub>(HS)</sub>R.

The main objective of the COMAH assessment is to prevent or mitigate the effects of major accidents with hazardous materials that may cause a harmful impact on human life and health, as well as the environment. While P(HS)R refers to land use planning according to the Seveso III directives.

Both regulations are based on knowledge incorporated in industry standards and experiences derived from previous accidents. Under these regulations there are no clearly defined rules as to whether VCE should be considered in a particular assessment situation, but the HSE has developed some guidance which may be of use in this regard, primarily aimed at LPG. Factors that include VCE hazards in risk assessment include [9]:

- reactive fuels, i.e. unsaturated hydrocarbons;
- the presence of (semi)confined structures near the point of release of hazardous substances;
- a large amount of spilled fuel that is sufficient to generate a gas cloud containing more than 10 t of fuel vapor;
- energetic release of fuel, i.e. spills from pressurized storage tanks, and
- presence of a strong ignition source.

An important technique for identifying potential factors that can influence the induction of higher pressure during a steam cloud explosion involves a review of previously occurring incidents and accidents with a detailed analysis of their causes. However, the Buncefield accident report indicates very limited knowledge about high-pressure explosions in heavy gasoline spills, whose analysis is hampered by the specific conditions of storage locations and the lack of adequate risk assessment approaches [11].

By reviewing the previously accidents, three important aspects can be derived for improving hazard identification and risk assessment [9]:

- the explosion mechanism at the occurrence of a VCE accident must include a wider range of generating factors related to the pressure of the shock wave, such as vegetation, car parks, temporary buildings and the like;
- spilling of a flammable substance and the creation of a massive vapor cloud in future risk assessments should be considered with very low or zero wind speed so that the modeling conditions match the so-called. a floating cloud of vapor with significant potential for prolonged release of a hazardous substance, and
- all other influential factors in the event of VCE accidents are related to the prolonged release of substances due to the absence of detection of a flammable mixture.

## VI. CONCLUSION

An important technique for identifying potential factors that can influence the induction of higher pressure during a steam cloud explosion involves a review of previously occurring incidents and accidents with a detailed analysis of their causes. In addition to the regulations, aspects and factors for risk assessment mentioned in the paper there are several methods for determining the overpressure in the VCE effect, such as empirical models and Computational Fluid Dynamics, because empirical models are relatively simple, reflect the real situation only for narrowly defined conditions, while Computational Fluid Dynamics implies software simulation under different conditions with the application of a significant level of knowledge and experience.

It is necessary to develop methodologically oriented concepts based on expert systems that

would show the degree of risk for early warning of accidents through existing standards, regulations, methods, statistical analyzes and procedures with complete compatibility with available control and safety systems which would significantly contribute to reducing of the occurrence of accidents such as the VCE effect, and thus would increase the degree of safety and security of people, but also for the environment and material costs.

## REFERENCES

- [1] Vilchez, J. A., & Casal, J. (2010). El riesgo químico y el territorio. *Rev. Catalana Segur Pública*.
- [2] Tepić, G., & Kostelac, M. (2021). Accidents in the System of Hazardous Substances. In *3rd Virtual International Conference Path to a Knowledge Society-Managing Risks and Innovation*, (pp. 355-359).
- [3] Chang, J. I. & Lin, C. (2006). A study of storage tank accidents. *Journal of Loss Prevention in the Process Industries*, 19(1), 51–59.
- [4] Sharma, R., K., Gurjar, B., R., Wate, S., R., Ghuge, S., P., & Agrawal, R. (2013). Assessment of an accidental vapour cloud explosion : Lessons from the Indian Oil Corporation Ltd . accident at Jaipur , India. *J. Loss Prev. Process Ind.*, 26(1), 82–90.
- [5] Koshy, A., Mallikarjunan, M., M., & Raghavan, K., V. (1995). Causative factors for vapour cloud explosions determined from past-accident analysis, *Journal of Loss Prevention in the Process Industries*, 8(6), 355–358.
- [6] MoPNG. (2010).
- [7] Abdolhamidzadeh, B., Abbasi, T., Rashtchian, D. & Abbasi, S. A. (2010). A new method for assessing domino effect in chemical process industry. *J. Hazard. Mater.* 182(1–3), 416–426.
- [8] Kletz, T., A. (1986). Transportation of hazardous substances: The UK scene. *Plant/operations Prog.*, 5(3), 160–164.
- [9] Herbert, I. (2010). The UK Bunce field incident The view from a UK risk assessment engineer. *J. Loss Prev. Process Ind.* 23(6), 913–920.
- [10] BMIIB, (2007). Explosion Mechanism Advisory Group report, Marlowe Road, Rose Court.
- [11] BMIIB, (2008). The Buncefield Investigation, [Www. Explosionsolutions.Co.Uk](http://www.Explosionsolutions.Co.Uk)



# The Simulation of Stable Systems for Fire Extinguishing as Advance Step in Fire Protection

Radoje B. Jevtić<sup>1</sup>, Ivana D. Janković<sup>2</sup>, Momčilo B. Randjelović<sup>3</sup>

<sup>1,2</sup>School for electrical engineering “Nikola Tesla”, Niš, Serbia

<sup>3</sup>Serbia University Business Academy in Novi Sad, Faculty of Social Sciences Belgrade, Belgrade, Serbia

<sup>1</sup>milan.jvtc@gmail.com, <sup>2</sup>Ivana.etstesla@gmail.com, <sup>3</sup>mocaprof@gmail.com

**Abstract**—Fire presents current and always open problem of every day’s human life and work. Modern life demands modern and effective solutions on every field, even in the field of fire protection. One of the very effective solutions for fire extinguishing are stable systems for fire extinguishing. Design and installation of these systems can be very difficult, demanding and expensive. So, it is very good way to use the simulation software to simulate these systems and to predict some eventual failure or lack and to have insight in their efficiency. This paper was written to present the use of FDS simulation software in simulation of stable systems for fire extinguishing.

**Keywords** – fire, extinguisher, simulation, FDS

## I. INTRODUCTION

Fire has always presented great danger for human, animals and material properties since man knows about himself. Through history, many different systems for fire protection and fire extinguishing have designed and realised. No matter to constant technology development and usage of modern systems for fire extinguishing, fire presents always open problem. Modern systems for fire extinguishing present very complex systems consisted from many different elements intended to detect and extinguish fire as much effective as possible. One of those systems are stable systems for fire extinguishing. Generally, stable systems in fire protection have great appliances: as sprinkler stable systems, as drencher stable systems, as stable systems with inert gases, as smoke and heat removal stable systems, as stable systems

with aerosol, as stable systems for detection of steams and gases, as stable systems for fire detection, as stable systems for fire extinguishing with dust, as stable systems for fire extinguishing with foam, as stable systems for fire extinguishing with CO<sub>2</sub> gas etc.

It is an interesting fact, statistically determined, that number of fires in object with stable systems for fire protection is equal with number of fires in objects that don’t possess that system. But the time needed to detect fire and to start its extinguishing is much shorter with much better extinguishing results. Stable systems for fire extinguishing can be realised on different ways and with different extinguisher. Fire extinguisher in these systems can be water, CO<sub>2</sub> gas, dust, foam, inergen, halon or some of the “new fire extinguishers”.

The most important advantages of stable systems for fire extinguishing are fast reaction in the sense of extinguishing activation and at the same time fire detection. Because of these systems complexity, very important things related to stable systems are precise designing and installation so as detail maintenance and servicing. These systems must be periodically tested and examined in order to identify their functioning and correctness.

Only professional and authorized persons which possess necessary licenses and approvals from appropriate inspections can handle the design, installation and testing of stable installations [1].

## II. FDS SIMULATION SOFTWARE

FDS (Fire Dynamic Simulator) software presents very important engineering software tool intended for solving of equations related to many fire problems. This software was written in Fortran language. FDS enables visual spreading of fire and smoke with particles and lot of other things related to fire (temperature, carbon monoxide, influence of water on fire etc.). Software FDS possesses its graphic integrated environment known as PyroSim. PyroSim has great advantages related to supply of input data, input simulation model, designing of 2D or 3D simulation model with powerful driving tools etc. Very important characteristic is the possibility to import simulation model from some other software, such as Auto Cad or similar. It enables designing very complex geometrical objects.

There are many versions of FDS software on the market. FDS versions used for purposes of this paper were 6.6 and 6.7.6 [2,3].

## III. SIMULATION OF STABLE SYSTEMS FOR FIRE EXTINGUISHING - SPRINKLER TYPE SYSTEMS

Stabile systems for fire extinguishing-sprinkler type systems present stabile installations for fire extinguishing with splashing jet of water. They are used wherever is possible to use water as fire extinguisher. Fire extinguishing is realised by determined number of nozzles, in dependence of fire spreading speed. In normal, stand by regime, this type of system has closed nozzles. Very important thing is that when the nozzles are activated, at the same time, fire detection occurs. This is because every sprinkler nozzle present at the same time and thermomaximal fire detector.

Sprinkler systems and installations present the oldest and the most effective stabile installations for fire extinguishing. As an example, in America, in period from 1896 to 1970, those installations were successfully extinguishing fire in 96 % of cases, with very small number of human victims. It is interesting that in those occasions 70 % of fires were controlled with less than five nozzles, while in residential buildings only one activated nozzle extinguished fire.

The way of activation of these systems lies in the fact that increase of temperature above some specific level causes splashing or melting of ampoule located at nozzle of sprinkler system.

This enables that nozzle gap becomes open and pressure of water or air in pipe becomes low. As a consequence of pressure drop, the sprinkler valve located in sprinkler station becomes open and water in water tank, which is under air pressure, flows through sprinkler valve and supplies sprinkler nozzles. Less quantity of water flows through electrical signal device which activates mechanical bell. In the case that the first nozzle doesn't extinguish fire, so fire became spreading, the next nozzle opens in the direction of fire spreading. In the case that whole volume of water in water tank is consumed, the sprinkler pump is activated and the system is supplied with water from special water pool or water net.

In the dependence of local conditions (temperature, way of functioning etc.) sprinkler installations can be realized as dry sprinkler installations, wet sprinkler installations, combined sprinkler installations, dry fast activated sprinkler installations and dry sprinkler installations with previous management. The examples of sprinkler installations are presented on Fig. 1.



Figure 1. The example of sprinkler system installation realization [1]

Simulation object with sprinkler installations in FDS software was object with dimensions of 24.5 m x 24.5 m x 3.2 m. The object had six separated rooms. The dimensions of one room were 8 m x 3 m x 3.2 m. The whole object was simulated as object from concrete. Simulation of smoke and flame spreading and thermal presentation of sprinkler extinguishing in FDS are presented on Figs. 2,3,4 [1,4].

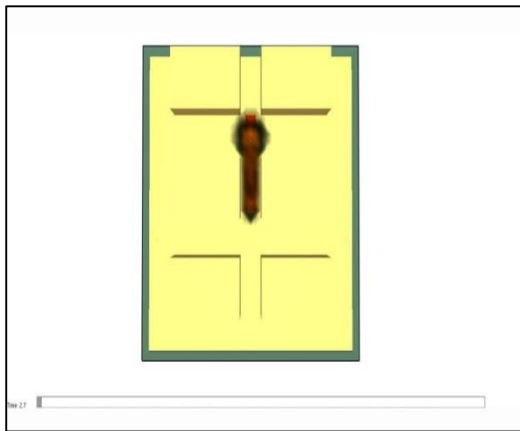

Figure 2. Simulation of smoke and flame spreading with sprinkler reaction after 2.7 seconds from fire start [4]

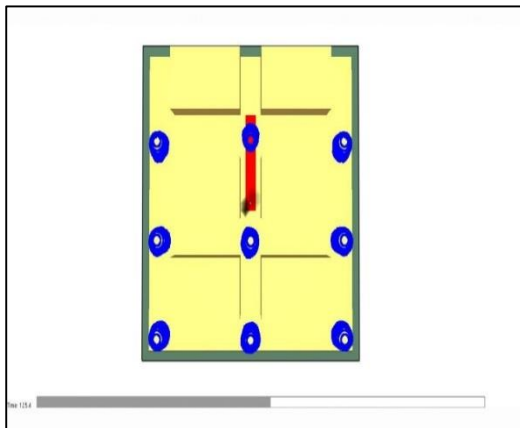

Figure 3. Simulation of smoke and flame spreading with sprinkler reaction after 2.7 seconds from fire start [4]

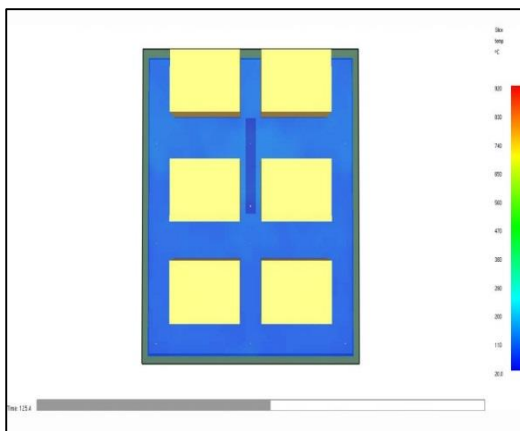

Figure 4. Thermal presentation in FDS of sprinkler reaction after 125.4 seconds from fire start [4]

#### IV. SIMULATION OF STABLE SYSTEMS FOR FIRE EXTINGUISHING - DRENCHER TYPE SYSTEMS

Stabile systems for fire extinguishing-drencher type systems present automatic stabile installations for fire extinguishing with water, similar as sprinkler systems, but with difference that after fire is detected, all nozzles installed in protected area take part in extinguishing. It is so called group extinguishing. Very often, statistically proved, occurred fires were very fast in their spreading and installed sprinkler systems couldn't extinguished fire with limited number of nozzles, although they reacted right in time. It was noted that main reason for this was in too long time needed for sprinkler systems activation.

Related to sprinkler systems, drencher systems also have long time of activation, but their advantage is in the fact that when they are activated, the whole area is being extinguishing at the same time. Because of their efficiency in extinguishing related to the sprinkler systems, drencher systems are commonly used in objects with high fire risk and in objects where high speed of fire spreading exists. Object where drencher systems must be installed are objects such as refineries, paint factories, drying plants and other similar objects that must be submerged by water in the case of fire.

Drencher installation has several technical solutions, different related to way of installation activation, way of water supply and system of activation. Because of its own characteristics, drencher installation has a special activation system with lot of different elements. That purports determined differences between this and sprinkler system, especially in nozzles. Drencher nozzles must possess nozzles with at least 8 mm diameter gaps and between distance not bigger than 3 m.

There are several ways that drencher installation can be activated: mechanic way, pneumatic way, hydraulic way, electric way and combined way. Drencher systems are often used to form so called "water curtain" in order to stop fire spreading and as cooling systems as a protection from high temperatures. In this case, water supply must be provided for at least two hours. An example of drencher installation for fire extinguishing is present on Fig. 5.



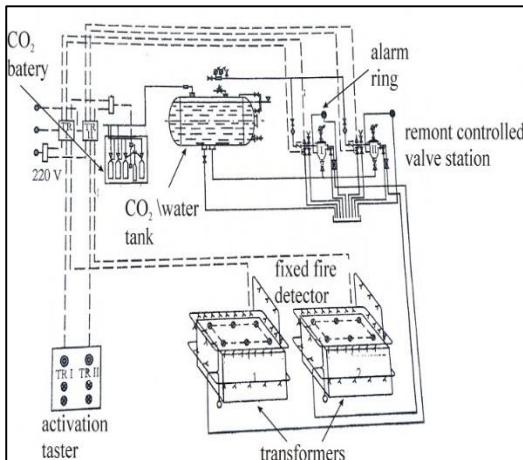

Figure 5. An example of drencher installation for fire extinguishing [1]

Simulation object with drencher installations was auto garage, with dimensions 50 m x 30 m x 3.5 m. Auto garage was built from concrete. There were 53 cars in garage. Every car had dimensions 4,2 m x 2 m x 1,5 m with the distance between cars of 1 m. Simulation model in FDS with the drencher nozzles arrangement at the auto garage and burner's position at the corner of the garage are presented on Fig. 6, while activated drencher system in auto garage above the cars and thermal presentation after 65 seconds from the fire beginning are presented on Figs. 7, 8 [1,5].

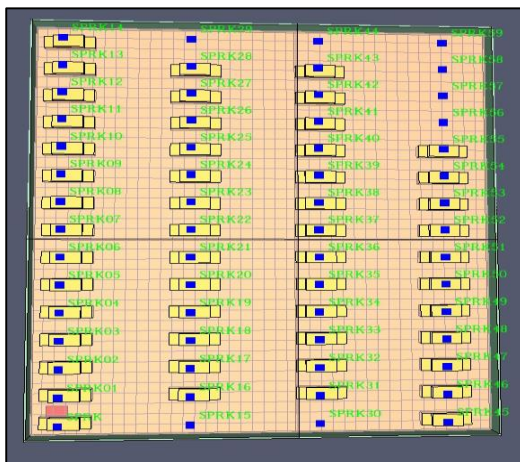

Figure 6. Simulation model in FDS with the drencher nozzles arrangement at the auto garage and burner's position at the corner of the garage [5]

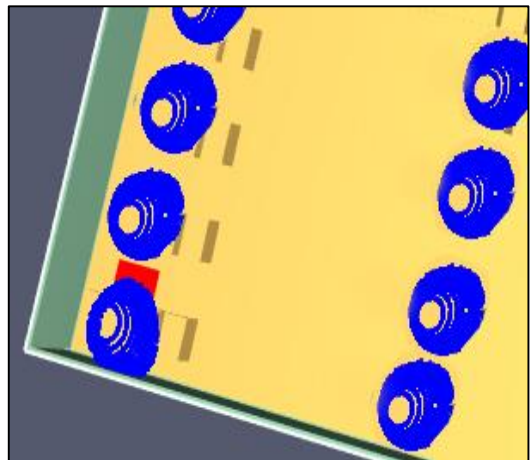

Figure 7. Activated drencher system in auto garage above the cars [5]

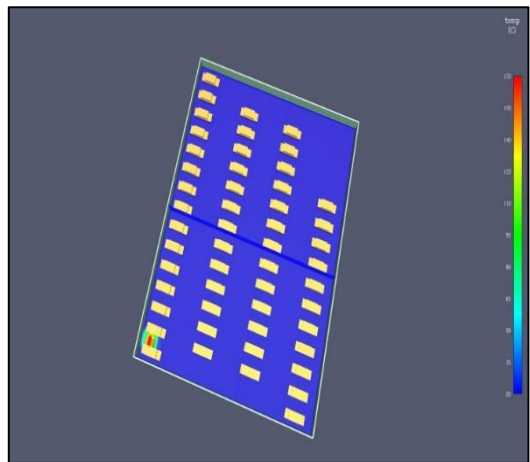

Figure 8. Thermal presentation of the auto garage after 65 seconds from activation of drencher system [5]

## V. SIMULATION OF STABLE SYSTEMS FOR FIRE EXTINGUISHING WITH CO<sub>2</sub> EXTINGUISHER

Stable systems for fire extinguishing with CO<sub>2</sub> use this gas as fire extinguisher. These installations are intended for extinguishing over whole volume-so-called three-dimensional extinguishing. It is very important to note that stable systems for fire extinguishing with CO<sub>2</sub> as fire extinguisher can be successfully used only in objects where all potential gaps don't exceed more than 3 % of room's volume. In other case, the extinguish effect will not be enough.



Figure 9. An example of activated CO<sub>2</sub> stable system in storage

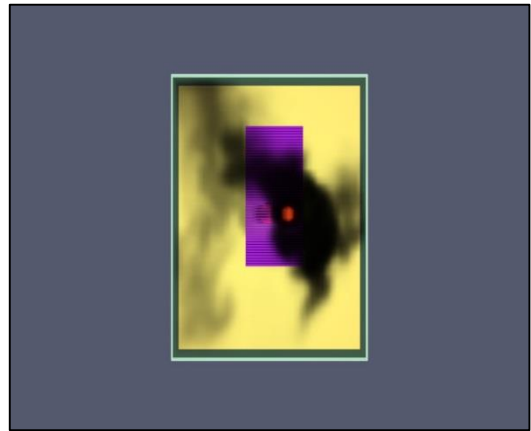

Figure 11. Simulation of fire and smoke spreading on electric transformer in FDS [6]

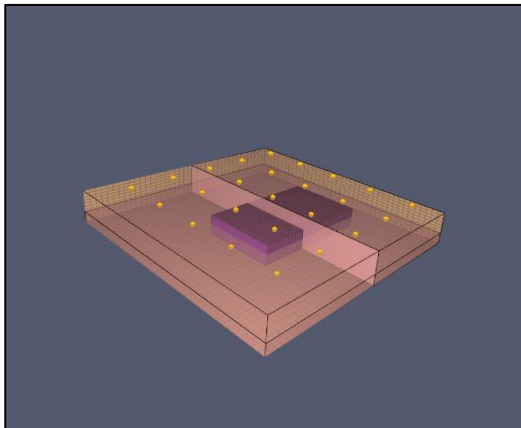

Figure 10. Simulation model of the room with electric transformer in FDS [6]

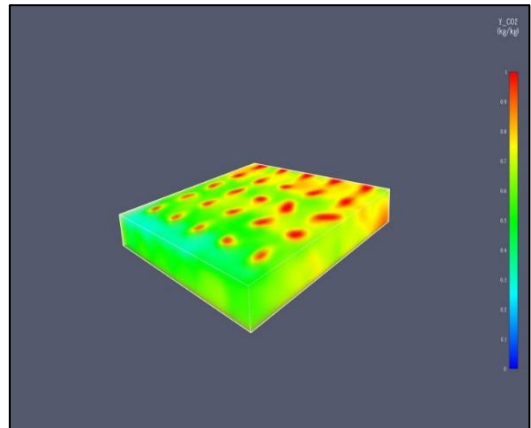

Figure 12. Simulation of activated CO<sub>2</sub> stable system in FDS [6]

Also, it is important to stop every potential technological process and airflow before the activation of stable system with CO<sub>2</sub> and to close every potential door, windows, wholes or any other kind of gaps.

The protection with these systems can be complete or partial. Complete protection purports that whole volume must be closed, while in other case protection is applied only on some particular part of the room or object and in the cases when the complete protection is not possible because of some technical reason. Of course, in the case when the partial protection is used, much bigger quantity of CO<sub>2</sub> gas is needed.

Generally, stable systems for fire extinguishing with CO<sub>2</sub> gas have next elements: bottles or tanks of CO<sub>2</sub> gas, pneumatic and mechanic valve for bottles, collection and exhaust pipes, high pressure rubber hoses

equipped with no-return valves, scale, electro-mechanical trigger, bob with micro clutch, bar of activation mechanism, battery frame with protective net and manual activation box.

The principle of activation is such that in the case of fire electromechanical trigger opens two bottles filled with CO<sub>2</sub> gas. These bottles activate pneumatic valve and open other bottles of CO<sub>2</sub> gas which is brought to the fire location by pipes and nozzles. Of course, before activation of the electromechanical trigger, partition valve that leads to the volume must be activated and opened. The activation of these systems can be different, in dependence of activation way, transfer activation commands and CO<sub>2</sub> gas guidance in the protected volume. So, it can be used next activation systems: manual systems, mechanical systems, mechanical-pneumatical systems, mechanical-electrical systems and electrical-

electrical systems. An example of activated CO<sub>2</sub> stabile system in storage is presented on Fig. 9.

The most important thing related to this system is to precisely calculate enough amount of CO<sub>2</sub> gas. The smallest possible amount of CO<sub>2</sub> gas, in dependence of different parameters and conditions is defined by technical regulation.

Simulation object was room intended for electric transformer. The room dimensions were 25 m x 25 m x 3 m, while the transformer's dimensions were 8 m x 8 m x 1,5 m. Room was built from concrete while transformer was built from steel and iron, with determinate quantity of oil. Simulation model of the room with electric transformer in FDS is presented on Fig. 10, while fire and smoke spreading simulation on electric transformer and activation of CO<sub>2</sub> stabile system are presented on Figs. 11 and 12.

## VI. CONCLUSION

Stabile systems for fire protection present very powerful installation in fire protection. These systems are designed for fast detection and extinguishing of fire. Designing, installation and testing of these systems are very complex, demanding and expensive. Any kind of mistake or inaccuracy could cause serious problems.

Noted examples showed the importance of simulation software usage in designing and testing of these systems with precise calculation of spent extinguisher and its effects and, what is also important, about potential mistakes that can be corrected immediately. The usage of simulation software in fire protection presents advanced step in the sense of safety, precision and economy. Correctly designed, installed and periodically tested stabile system is always prepared to achieve full effect. Because of that, simulation software must be obligated engineering tool in designing, calculating and testing of stabile systems for fire protection that use water and CO<sub>2</sub> gas as fire extinguisher.

## REFERENCES

- [1] Jevtić, R. B. (2019). Material for the preparation of the professional exam in the field of fire protection. *Gradski Vatrogasni Savez Niš*, 502-507.
- [2] McGrattan, K., Hostikka, S., Floyd, J., McDermott, R., & Vanella, M. (2021). Fire Dynamic Simulator. *National Institute of Standards and Technology*.
- [3] Thunderengineering. (2020). *Pyrosim User Manual*, version 20(2).
- [4] Jevtić, R. B. (2018). Stabile systems for fire protection: Sprinkler type systems. *Tehnika*, 73(4), 581-586.
- [5] Jevtić, R. B. (2019). Stabile systems for fire protection: Drencher type systems. *Tehnika*, 74(6), 903-909.
- [6] Jevtić, R. B. (2020). Stable fire extinguishing installations with CO<sub>2</sub> fire extinguishers. *Tehnika*, 75(4), 527-533.

# Blockchain as a Methodology in the Implementation of Sustainable Tourism

Vladimir Živanović<sup>1</sup>, Marko Živanović<sup>2</sup>

<sup>1,2</sup>Faculty of Business Studies, Megatrend University, Belgrade, Serbia

<sup>1</sup>vzivanovic@megatrend.edu.rs, <sup>2</sup>mzivanovic@megatrend.edu.rs

**Abstract**—The implementation of new technological solutions based on cryptocurrencies and blockchain methodology should be presented as a basic, and not as a disruptive factor in development. Within the tourism industry, there is an increasing evolution in the field of informational and communicational technologies that are introducing a revolution in travelling and choosing tourist destinations. A wide range of new services can be offered through the implementation of informational and communicational technologies. With the implementation of blockchain-based technologies, the service of central tourism intermediaries becomes redundant due to the transfer of these intermediary functions to all participants in the system which could be managed collectively through transparent rules and participants' computers. Precisely due to the decentralized management system, which offers a blockchain methodology, its popularity in the market is growing as implementation by end-users of these services. Blockchain helps in the creation of cyber-attack-resistant digital data storage systems as well as a data-sharing platform using linked data verification block structures and a reliable end-user consensus mechanism for the data synchronization process. This paper will analyze the use of blockchain methodology in the implementation of new services in the sector of tourism.

**Keywords** - blockchain, cryptocurrencies, informational technology, international financial markets, sustainable tourism

## I. INTRODUCTION

The tourism sector has undergone a transformation and improvement related to the

scope of service provision during the last years of the last century. Like all other industries, the reason for the growth and improvement of services lies in the implementation of new technological solutions, which are primarily based on new informational technology. Tourism service providers have sought to provide their services to as many users as possible by making tourism services more accessible, visible, simpler and ultimately cheaper. In this sense, the aim was to simplify the processes related to the realization of tourist services, which should be as accessible as possible to the widest possible number of end-users in all parts of the globe. One of the most important activities of tourism service providers was related to visibility. Visibility is linked to the advertising and marketing process so that information about service providers can reach end-users as easily and at the lowest possible cost. In this sense, the role of digital marketing has a primary role, and digital marketing services are available every day to an increasing number of end-users through social networks. All previous activities have led to the improvement of services at the level of the tourism industry, which has led to increased productivity, and thus lower prices of services.

The accelerated development of the tourism sector at the beginning of this century has a significant decline in the value and total number of trips and overnight stays of tourists during 2019-2022 due to extraordinary economic circumstances caused by the COVID-19 pandemic. The rise in popularity of cryptocurrencies has also led to improved blockchain services to enable an increased

volume of exchange with these new virtual currencies while raising the level of security and security of transactions between end-users. To enable the acceptance of cryptocurrencies at the level of tourism service providers, it was necessary to implement new informational services based on the blockchain methodology.

## II. LITERATURE REVIEW

The phenomenon of blockchain technology (BTC) has emerged in the last ten years as a result of the implementation of decentralized computer networking and security in the process of communication between end-users of services. Blockchain is seen as the key to informational technology innovation that can change many systems over the next decade [1]. Satoshi Nakamoto, a pseudonym for the blockchain concept inventor, wrote a white paper on bitcoin in 2008 and defined a phenomenon based on a peer-to-peer version of electronic cash without the use of financial intermediaries such as commercial banks or financial institutions [2]. In 2015, The Economist called the blockchain “the next big thing”, referring to technological advances and innovations that the blockchain could bring in several areas. [3]. In this sense, were primarily meant the revolution of electronic payment and the use of the latest forms of cryptographic protection in data transmission, which is based on the blockchain methodology.

Blockchain is based on the reproduction of large amounts of data registers through *virtual contracts* between end-users around the world, thus avoiding the use of intermediaries. In this way, *smart contracts* or *digital identification documents* (IDs) are created to support many business activities within the direct “peer-to-peer” exchange. [4]. The implementation of the blockchain methodology is different depending on several sectors of the industry. According to Kwok and Koh [5], blockchain can be applied in six domains in the tourism industry, including the exchange process, providing better processes and lower costs, and as well as improving the user experience. These activities are particularly visible in areas such as booking, which can be implemented at the hotel, car rental, insurance and airline booking.

As the second activity of implementation of blockchain methodology in the tourism industry, it appears in the part of end-user identity management, such as passenger identification, personalization and luggage tracking. The third

activity of using the new methodology is in the part of the loyalty program, such as the realization of various discounts and incentives for tourists or reward programs based on the users’ service loyalty. Digital payment for tourist services appears as the fourth activity that, in addition to traditional forms of payment, is enabled B2B model which is based on the use of cryptocurrencies and settlement processes. The fifth activity is related to the letters of credit through the authenticity of review, ranking and verification by tourism service providers. The last sixth activity of the benefits of using the new technology derives from inventory management through the process of direct distribution and the creation of a network of suppliers.

Blockchain is a decentralized database system with a strong security data protection system the series [6]. It can also be defined as a public ledger that distributes and records all user transactions online [7]. By using digital ID, blockchain technology allows passengers to no longer have to present physical ID cards, which ultimately facilitates travel and reduces waiting times when travelling. The use of blockchain technology can help interested companies to create secure digital records, and also enables secure storage of data on end-users and all related transactions. Application solutions that enable the use of cryptocurrencies in the process of paying for services can save significant funds both from the end-users of tourist services and from the position of tourism service providers. Cost savings occur in the form of no transaction costs when using payment services via the blockchain platform. In this way, end-users of services can book hotels and make reservations and purchase an airplane and other tickets for transportation without the use of intermediary companies that charge brokerage fees [8]. End-users can use blockchain technology to access all the necessary information regarding travel via peer-to-peer data transmission, which eliminates the need to use central servers for travel services. With the implementation of application solutions based on blockchain technology, it is possible to apply transparency in transactions as well as the usage of all activities that are visible to end-users without the need for third parties to conduct final transactions and activities related to tourism services [8-11].

The impact of technology and the Internet on the tourism industry is undeniable. The implementation of the new technology began

with the use of reservation systems based on networked computers. This first phase in the development of tourism services based on new technologies was followed by a phase based on the global distribution system, while the last phase of development is closely related to the development of the Internet, which together with the previously mentioned development phases significantly changed supply and demand in the sector of tourism [12]. The Internet has enabled suppliers within the tourism industry to distribute their products directly, and tourism service providers to sell services based on online services (OTA). An important advantage of using the Internet in modern tourism is the use of metadata of users who use search engines, which facilitates the process of obtaining information about the needs of end-users for the most important providers of tourist services. Blockchain is expected to become the fifth disruptive computing paradigm after mainframes, computers, the Internet and mobile/social networking [13].

Iansiti and Lakhani [14] see blockchain as a core technology, not a disruptive one, as potentially new economic and social systems can be based on blockchain. They also believe that the adoption of the blockchain will come gradually. Therefore, understanding the blockchain and considering its impact on the tourism industry is essential. The introduction of a blockchain in tourism raises several issues and problems, such as disrupting established business models, changing demand patterns, managing data or adopting technology in small and medium-sized enterprises.

### III. IMPLEMENTATION OF BLOCKCHAIN-BASED METHODOLOGY IN THE TOURISM INDUSTRY

The widest application of new technology based on blockchain methodology at the level of the tourism industry is in the form of new application platforms for organizing and scheduling travel and using services at the hospitality level, which accept cryptocurrencies as payment methods. *Winding Tree* is one example of using new information solutions based on blockchain technology. This is a decentralized distribution platform, where consumers can directly access suppliers' offers. Based on the application solution, it is possible to manage stocks in terms of displaying the inventory of accommodation and prices in real-time that can be shared between

stakeholders [15]. The second application takes the form of loyalty programs based on blockchain, which can be used by hotels, airlines and any other tourist and catering facilities. By creating a loyalty program based on the blockchain, loyalty tokens are used, which are issued as rewards to guests in the form of loyalty points. The advantage of a loyalty program based on the blockchain methodology is that the collected tokens can be sold or exchanged between other participants in the network [16]. Loyalty tokens from different companies can have different values. As a result, the implementation of blockchain-based loyalty programs can have a positive impact on increasing competition and service quality [16].

An example of a loyalty program based on the blockchain methodology is *Loyyal*, which was created for this purpose and which aims to solve the problem of the accumulation of digital tokens. All collected loyalty tokens of the user are accumulated on his user account and thus enable the collected tokens can be used to achieve benefits in any organization that has implemented a loyalty program based on blockchain. Another example of the use of the blockchain methodology can be observed at the level of the airline sector. The methodology e.g. can be used in tracking passengers' luggage. Using blockchain, airlines can create their blockchain and thus track the luggage of their passengers within their internal system. Based on the application of this new application solution, it is easier to locate luggage wherever it is during transit, and at the same time reduce the number of lost luggage.

The third positive example of using the blockchain methodology is the implementation of *smart contracts* at the level of the tourism industry as a whole. Smart contracts based on the blockchain can be created between hotels and travel agencies. This speeds up the time and volume of payments between partners as the smart contract system helps increase sales of travel arrangements by providing safer and better real-time information [16]. On the other hand, the application of smart contracts facilitates the process of supply in restaurants, as well as tracking ordered stocks. This allows you to manage orders while tracking delivery times. The implementation of blockchain-based application solutions provides an opportunity for management to monitor the entire food supply chain. In the case of malfunctions in some foods, the history of the supply chain can be easily

determined through the blockchain methodology. One of the largest tour operators, such as the TUI group, has developed an internal blockchain-based system called *BedSwaps*. *BedSwaps* application solution uses internal smart contracts that manage accommodation offers in real-time [17].

In practice, there are other potential uses of blockchain in various fields, which can be applied to tourism and hospitality. This includes the possession of digital personal documents that can replace passports and all other identification documents such as birth certificates and/or the use of driving licenses. This could reduce unauthorised usage of identity and facilitate document verification [16,18].

Some other advantages of the blockchain-based system for travellers include the function of re-booking when the price of the travel arrangement falls, the possibility of realizing transactions via cryptocurrencies [19], ticket resale such as e.g., plane tickets [20] and the availability of cheap package tours through the integration of travel and hospitality portals [21].

In general, it is expected that information technology using blockchain methodology can replace centralized systems (such as OTA) by introducing a decentralized system that would also be reliable and secure [10]. Moreover, blockchain can improve coordination between stakeholders. For example, if a passenger does not check in for a flight, blockchain-based information technology automatically adjusts and updates the inventory of car rental companies and hotel availability at the location where the non-boarding passenger should be travelling, based on the networking of all participants in the system [15].

#### A. *Economic aspects of the blockchain*

In economic terms, Catalini and Gans [22] identify two central types of costs affected by the blockchain such as verification costs and networking costs. Blockchain-based digital markets are characterized by low verification costs, and the use of common network infrastructure, without the use of an intermediary to manage the platform such as the case in traditional two-way markets. Other economic advantages of the blockchain include increased competition, low entry barriers and low privacy risk. On the other hand, some authors point out blockchain-specific inefficiencies such as the need to rely on

endogenous information and limitations within the existing legal and regulatory system [22]. Abadi and Brunnermeier [23] conclude that blockchain is not able to fulfil three qualities of an ideal ledger book at the same time, such as correctness, decentralization and cost-effectiveness. In practice, we can analyze the four main economic challenges of blockchain adoption [24]. These are the complexity of technology, the technical aspects of new technological solutions, the existence of concerns about system scalability and the need to implement supportive and effective policies. Swan concludes that the overall economic benefits of the blockchain (especially in the areas of identity verification, fund transfers, asset registers and smart contracts) will outweigh all these challenges by remodelling existing economic practices in the light of the internet revolution [24]. Arruñada and Garicano [25] state that due to the introduction of decentralized management, the blockchain can economically outperform centralized intermediaries. For blockchain-based cryptocurrencies such as Bitcoin, Ethereum, KSRP and many others, it should be noted that the term “currency” can be misleading in terms of interpreting cryptocurrencies as “money” because cryptocurrencies are not traditional forms of money issued by central banks and which are under the direct regulatory control of the central monetary authorities. Böhme [26] has previously argued that Bitcoin has the potential to disrupt payment and monetary systems, but cryptocurrencies still do not fully fulfil the traditional functions of money [27] whether used in tourism and hospitality and wider.

The functions of money as a “medium of exchange” and/or as a “common measure of value” can also be applied using cryptocurrencies. However, the use of cryptocurrencies as a traditional “value standard” or the use of value hoarding as in the classical form of money is still not fully achievable, primarily due to the lack of regulatory control and consequent high volatility of all cryptocurrencies in the financial market. The use of cryptocurrency is not accepted as a legal instrument of payment in the vast majority of countries. Japan is a pioneer in the official acceptance of cryptocurrencies such as bitcoin in payment transactions [28].

The traditional function of money, which refers to the hoarding of values, is currently



unfeasible in cryptocurrencies for two main reasons. The first reason refers to the high volatility of cryptocurrencies, i.e., the high change in the nominal exchange rates of cryptocurrencies due to the influence of most often short-term speculative demand. For these reasons, it can be said that cryptocurrencies do not have external stability. Another reason for the impossibility of using cryptocurrencies as an instrument of payment and hoarding of values lies in the fact that the supply of certain cryptocurrencies such as bitcoin is limited, which does not guarantee investors that its value will not erode due to the falling supply of new bitcoins when bitcoin-denominated prices increase due to investor distrust in the future sustainability of this cryptocurrency. All this could affect the reduction of trust and acceptance of cryptocurrencies in the future. The lack of internal stability of cryptocurrencies can also be defined as their basic shortcoming in wider international implementation.

#### IV. OPERATION OF THE BLOCKCHAIN-BASED TECHNOLOGY

The blockchain methodology is based on a combination of data and transactions that are progressively registered and monitored through a network of distributed books [29].

The advantage of blockchain technological solutions is that they are based on the formation of a decentralized network of users (peer-to-peer), which is designed to operate without a central authority in the control of data transmission and transactions between end-users. The main ledgers book is synchronized with the entire network and transactions take place without the need for third-party intervention [30,31]. The development of such a structure ensures that the system is open to anyone who wants to execute valid transactions [32].

Fig. 1 shows the different architectures of the end-user communication system, often called nodes [32]. The left figure shows a distributed system in which users communicate directly or indirectly with each other without the need to use a single centralized participant, as shown in the right figure where we have one centralized participant in communication through which communication between individual users.

In Fig. 2, in contrast to the previously shown figure, we can see two different architectures that are based on the formation of hybrid

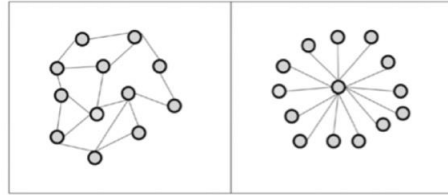

Figure 1. Arranged against the centralized system architecture.

systems [32]. On the left, we have the architecture characterized by the presence of a centralized component within the distributed system. With this system, all participants communicate with an already centralized user in the middle. It looks like this architecture of the system is evenly distributed, but in reality, it is a centralized system. The right side also shows a seemingly centralized system, but in fact, it shows a decentralized structure, as other users communicate with a previously formed central unit formed based on decentralized communication within the central component.

The use of cryptographic algorithms means that each node connected to the network provides a high level of security when performing or validating transactions [2,14,31,32]. This ensures safer, anonymous, traceable and decentralized access to users [2]. The identification code, called the “hash”, is contained in each appendix made in the further chain of data transmission. The advantage of a decentralized system based on blockchain methodology is that the exchanged data can be monitored with a higher level of accuracy [33], which further strengthens the security of the system itself.

At the lowest layer are signed transactions that are grouped into blocks. The second layer, the consensus layer, is responsible for ensuring that all nodes agree on which transactions must be stored in the blockchain, to ensure the absence of corrupt branches and divergences.

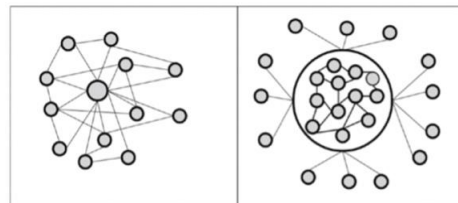

Figure 2. Mixed deployment versus centralized system architecture.



The third layer is the computer interface that is responsible for executing smart contracts. The last layer of management extends the architecture of the blockchain so that data from one process is permanently stored in the block and none of the previous users can change the structure of the information contained in it. In this way, security is achieved at the level of transactions between users and the possibility of data misuse by other participants in the network is prevented.

When the transaction is completed, a block appears. The block is then broadcast to all nodes in the network. One of the nodes validates the block and broadcasts it back to the network. If a block is verified, all nodes add it to their blockchain. Each subsequent block correctly points to the previous block. In this process, each transaction receives a unique string and timestamp, which guarantees greater accuracy in tracking data. Once a transaction is confirmed, it cannot be easily changed or deleted, and transparency is enhanced because transactions are shared across the network and everyone in the network can have access to the data in the future. At the same time, this helps to ensure security and thus creates trust between end-users.

The current scientific literature on the development of blockchain methodology claims that there are three generations in the development of blockchain technology.

The first generation is related to the emergence and development of bitcoin, which officially appears as the first digital currency. The second generation represents the introduction of smart contracts, which are based on the application of code which is made based on blockchain methodology and which facilitates the self-execution of contracts between end-users. The third generation is related to the current technology characterized by decentralized applications (DApps), which allows users to interact with new application solutions based on the blockchain methodology by directly using application solutions via smartphones or Internet browsers.

Various authors state that there are three types of blockchains in use, public, private and permitted. Public blockchains are stored in peer-to-peer networks in a completely decentralized and anonymous way, and anyone can join the network. Private blockchains are characterized by the fact that only certain private users can join

these networks. And finally, we have the allowed blockchains that require a set of trusted nodes responsible for creating blocks and only authorized users can connect to this network. Within the application solutions that can be applied at the level of tourist services, all three forms of chains can be used in the form of public chains for all potential users of tourist services, private chains that can be used at the level of tour operators or individual tourist organizations, and allowed chains that are implemented at the level of the blockchain application solution of a certain tourist organization, and which can be accessed only by authorized users who have authorizations from a specific tourist service provider. Based on previous mention application solutions, a network of users is created that enables everyone a faster and simpler way to communicate with the implementation of the highest standards in encrypted protection of data transmission or transactions, which are executed in real-time.

#### *A. Using a smart tourist destination within the sustainable tourism*

The phenomenon of smart tourism represents a new approach to the provision of tourism services through the application of new informational and communicational technologies (ICT) at the level of the tourism sector. Previous research has conceptualized a framework for smart tourist destinations based on the development of smart cities, research on the potential of smart tourist destinations to improve the tourist experience through personalization of services, developing a conceptual model for the competitiveness of a smart tourist destination and examining the effects of smart destination strategies and solutions on destination management processes and improving the tourist experience of tourists.

The main goal of a smart tourist destination is to improve the tourist experience based on the service provided and/or the content provided, as well as to improve efficiency in managing and creating a competitive advantage of a particular tourist destination and ensuring sustainability over time. All authors agree on the fact that the smart tourist destination service is based on the application of new informational and communicational technologies.

The conceptualization of ICT in the implementation of smart tourist destinations requires the interconnection of different interest groups in the realization of the final tourist

service. Finally, we can conclude that the main goal of using smart tourist destinations is to focus on and take care of the needs of end-users of tourist services through the application of ICT, intending to improve the quality of services and improve the management process in the tourism sector.

Boes [34] defines smart tourism destinations as places that use available technologies to jointly create value, satisfaction and experience for tourists, as well as provide benefits and profits for tourism organizations and destinations. On the other hand, we have the opinion of authors who define smart tourist destinations as destinations that intensively collect and use data obtained through the network to analyze and understand the needs of tourists and their behaviour so that tourism service providers can provide better services based on analyzed user experience in real-time [35,36].

Another group of authors argues that the development of smart tourism destinations would benefit the tourism industry by providing open access to data for both tourism organizations and tourists as end-users of services based on the implementation of a common platform [37-39]. The information found in the cloud service, a developed system of high-speed internet services and capacity in the information bandwidth, allows tourism service providers to create services in real-time for each potential user of the services of a particular tourist destination. Applicational and informational solutions based on blockchain methodology can help solve the challenges of real-time data processing through the use of smart tourist destinations [40].

## V. CONCLUSIONS

It can be concluded that tourism is one of the most promising sectors for the development of blockchain technology. We conceptualized the importance of blockchain technology in the implementation of smart tourism with a special focus on supporting the achievement of the implementation of smart tourism destinations. Given the highly competitive and innovative trends at the level of tourist destinations, blockchain technology can be a sustainable solution to improve the tourist experience, reward sustainable behaviour, provide benefits to local communities, and reduce privacy concerns. However, we must note that this paper does not aim to diminish the role of other

innovative technologies but to argue that combining blockchain technology with technologies such as the Internet or artificial intelligence can encourage the development of smart tourist destinations and positively contribute to achieving their goals. Blockchain technology can change the way data is collected, verified and used in the process of creating new value. New information and communication technology solutions based on the blockchain methodology enable equal, open access to data for small and medium enterprises as well as enable tourists to own and control their data. Knowing the risks associated with the adoption of blockchain technology, smart travel destination managers can help decide on the investment and implementation of new application solutions. This technology could touch on several aspects of the tourism industry, such as its business model, money transfer system, security, performance and trust. The positive impact of the blockchain methodology also enables other economic participants in the process to benefit from the adoption of this technology. It should be noted that cryptocurrencies based on blockchains such as Bitcoin, Ethereum and others are currently not generally accepted payment instruments because their issuance is not under the regulatory control of central monetary authorities. Their use in the form of traditional forms of money is not feasible due to the lack of regulatory control and the high volatility of cryptocurrencies in the international financial market. The use of cryptocurrencies is currently not accepted as a legal instrument of payment in the vast majority of countries. Their popularity is growing every day, especially among individual users and individual investors. This fact indicates that the goal of achieving sustainable tourism is to enable the use of cryptocurrencies as an instrument of payment. The development of payment in cryptocurrencies requires the use of informational and communicational application solutions based on blockchain methodology. After the implementation of these solutions, the tourism sector opens another additional space for attracting new categories of tourists who are supporting the usage of new technology and to whom the use of cryptocurrencies is not new. With the development of the system of tourist services based on the implementation of smart tourist destinations, the global tourism sector gets the possibility of direct marketing based on real-time information exchange with end

potential users of tourist services, which creates preconditions for sustainable tourism in the future.

## REFERENCES

- [1] Morabito, V. (2017). Business innovation through blockchain - The B3 perspective. Springer Publishing.
- [2] Nakamoto, S. (2008). Bitcoin: A peer-to-peer electronic cash system. *Decentralized business review*, 21260.
- [3] Economist. (2015). Blockchain, the next big thing - or is it?
- [4] Cutts, T. (2019). Blockchain and the Law: The Rule of Code.
- [5] Kwok, A. O., & Koh, S. G. (2019). Is blockchain technology a watershed for tourism development?. *Current Issues in Tourism*, 22(20), 2447-2452.
- [6] Khalifa (2018). Blockchain: The upcoming revolution in the world of management and finance. Futureuae.
- [7] Gatteschi, V., Lamberti, F., Demartini, C., Pranteda, C., & Santamaria, V. (2018). To blockchain or not to blockchain: That is the question. *IT Professional*, 62
- [8] Revfine. (2018). How blockchain technology is transforming the travel industry.
- [9] Beonprice. (2017). Blockchain's influence on tourism distribution.
- [10] Calvaresi, D., Leis, M., Dubovitskaya, A., Schegg, R., & Schumacher, M. (2019). Trust in tourism via blockchain technology: results from a systematic review. Springer International Publishing.
- [11] Malviya, H. (2019). 5 basic principals of blockchain Technology: What makes blockchain different and secure?
- [12] Buhalis, D., & Law, R. (2008). Progress in information technology and tourism management: 20 years on and 10 years after the Internet. *Tourism Management*, 29, 609–623.
- [13] Swan, M. (2015). *Blockchain: Blueprint for a New Economy*. O'Reilly Media, Inc.
- [14] Iansiti, M., & Lakhani, K. R. (2017). The truth about blockchain. *Harvard Business Review*.
- [15] Treiblmaier, H. (2020). Blockchain and tourism. *Handbook of e-Tourism*, 1-21..
- [16] Dogru, T., Mody, M., & Leonardi, C. (2018). Blockchain Technology & Its Implications for the Hospitality Industry. *Boston Hospitality Review*.
- [17] Marr, B. (2018). The awesome ways TUI uses blockchain to revolutionize the travel industry.
- [18] Davidson, S., De Filippi, P., & Potts, J. (2016). Economics of blockchain. *SSRN Electronic Journal*.
- [19] GOeureka. (2017). The next-gen solution shaping the future of online hotel booking.
- [20] Önder, I., & Treiblmaier, H. (2018). Blockchain and tourism: three research propositions. *Annals of Tourism Research*, 72, 180–182.
- [21] Varelas, S., Georgitseas, P., Nechita, F., & Sahinidis, A. (2019). Strategic innovations in tourism enterprises through blockchain technology. (pp. 885-891). Springer International Publishing.
- [22] Catalini, C., & Gans, J. S. (2019). Some simple economics of the blockchain. *NBoER*, 22952.
- [23] Abadi, J., & Brunnermeier, M. (2018). Blockchain economics. *National Bureau of Economic Research*.
- [24] Swan, M. (2017). Anticipating the economic benefits of blockchain. *TIMR*, 7, 6–13.
- [25] Arruñada, B., & Garicano, L. (2018). Blockchain: the birth of decentralized governance. *Barcelona GSE Working Paper Series*, 1038.
- [26] Böhme, R., Christin, N., & Edelman, B. (2015). Bitcoin: economics, technology, and governance. *Journal of Economic Perspectives*, 29, 213–238.
- [27] Jevons, W. S. (1875). *Money and the Mechanism of Exchange*. Appleton and Co.
- [28] Terazono, E. (2017). Bitcoin gets official blessing in Japan.
- [29] Felin, T., & Lakhani, K. R. (2018). What problems will you solve with blockchain? *MIT Sloan Management*, 32–38.
- [30] Hawlitschek, F., Notheisen, B., & Teubner, T. (2018). The limits of trust-free systems. *Electronic Commerce Research and Applications*, 29, 50–63.
- [31] Lacity, M. C. (2018). Addressing key challenges to making enterprise blockchain applications a reality. *MIS Quarterly Executive*, 17(3), 201–222.
- [32] Drescher, D. (2017). Blockchain basics: A non-technical introduction in 25 steps. Springer Publishing.
- [33] Seffinga, J., Lyons, L., & Bachman, A. (2017). *The Blockchain (r)evolution*. Deloitte.
- [34] Boes, K., Buhalis, D., & Inversini, A. (2015). Conceptualising smart tourism destination dimensions. Springer International Publishing.
- [35] Choe, Y., & Fesenmaier, D. R. (2017). The quantified traveler: Implications for smart tourism development. *Analytics in smart tourism design: Concepts and methods*, 65-77.
- [36] Xiang, Z., & Fesenmaier, D. R. (2017). Big data analytics, tourism design and smart tourism. *Analytics in smart tourism design: concepts and methods*, 299
- [37] Zhu, W., Zhang, L., & Li, N. (2014). Challenges, function changing of government and enterprises in Chinese smart tourism. *Information and communication technologies in tourism*, 10, 553-564.
- [38] Zhang, D., Hu, M., & Ji, Q. (2020). Financial markets under the global pandemic of COVID-19. *Finance Research Letters*, 36(101528).
- [39] Jasrotia, A., & Gangotia, A. (2018). Smart cities to smart tourism destinations: A review paper. *Journal of tourism intelligence and smartness*, 1(1), 47-56.
- [40] Korže, S. Z. (2019). How Smart Tourism Embrace Blockchains and Smart Contracts. *Journal of Innovative Business and Management*, 11, 32–40.

# Transportation Problem with Additional Bounded Capacity

Bratislav Lukić<sup>1</sup>, Goran Petrović<sup>2</sup>

<sup>1</sup> Ministry of Defense of the Republic of Serbia, Belgrade, Serbia

<sup>2</sup> University of Niš, Faculty of Mechanical Engineering, Niš, Serbia

<sup>1</sup>lukic.bratislav@yahoo.com, <sup>2</sup>pgoran1102@gmail.com

**Abstract**—For the data and decision parameters that are interconnected by the system of constraint functions, which affect the optimal value of the set goal, the size of the goal and the relevant factors can be said to be interrelated with the goal function. The optimal solution is the combination of conditions that gives the desired extreme value of the goal function, according to the adopted optimization criteria. The aim of this paper is to examine methods for solving a general transportation problem (TP) on solving a TP with additional capacity bounded. The definition of the TP with additional restriction and possible conditions was performed, as well as the application of three modified methods. The illustration of the numerical example represents a closed TP with additional bounded capacity from the top and bottom to determine the differences in the obtained values of the target function and show the rate of convergence of the initial base solution to the optimal solution.

**Keywords** – TP, bounded, methods, inital basic feasible solution

## I. INTRODUCTION

The main characteristic of operational research is the development of a mathematical model of the system or process being observed, on the basis of which it will be possible to predict and compare the consequences of different variants in the decision-making process [1].

A typical TP is the problem of distribution of goods from producers to consumers, provided that transportation costs are minimal. Various logistics problems in addition to the transportation of goods can also be formulated as TP. In addition, there are many tasks that are solved as TP, such as tasks of optimal placement of machines, plants, warehouses, energy

facilities, etc. with the aim of achieving greater economy of work and time [2].

As researchers have found a number of methods in order to reach the initial and optimal solution as easily and quickly as possible, so the requirements of users have expanded, so that in addition to quantities of materials - goods that need to be transported from source to destination, i.e. price transportation per unit of measure, there are additional restrictions in the form of capacity, time of transportation or a combination of these restrictions. This type of problem is called a TP with an additional bounded and is a more complex model, but the basis is to solve the TP with modifications of methods to determine the initial and optimal solution.

The TP is one of the problems of linear programming. One of the most useful methods by which the problem can be solved TP is the simplex method. However, its application is not rational due to a large number of bounded and variables, which is why various methods have been developed whose algorithms are simpler, which allow determining the initial basic solution, as well as finding the optimal solution to the TP. The trend of development and application of transportation methods has constantly being upgraded, with the increasing use of software programs with algorithms of the most efficient methods [2].

## II. LITERATURE REVIEW

The study of the transport problem using analytical methods dates back to the middle of the 20th century, when a model of the transport problem was formulated and solved, and when a study was presented in which method was

developed to solve the transport problem, which involves sending a single load from the source to a specific destination [3-5]. Since there was a need for more efficient methods, whose speed of convergence towards the optimal solution is higher than with the simplex method presented by [6], various methods for obtaining the initial basic solution are published [7-19].

The development of new methods for obtaining an initial and optimal solution is conditioned by increasing bounded in TPs. An inverse method has been proposed where no capacity bounded are known in advance, but estimates or previous experience are used [20]. Methods have been proposed where additional capacitive limitation from above is considered [21], bilateral and unbalanced capacitive bounded, bottleneck and flow bounded [22-24]. According to [25] transportation in addition to availability and demand, may have another bounded such as capacitive constraint. Then the problem becomes generalized solid TP with capacity, on the basis of which the solution procedure for find the optimal solution. In [26], modified methods for solving a TP with a capacitive constraint for obtaining an initial basic solution and simplex methods for a TP with bounded are presented.

### III. FORMULATION OF A TRANSPORTATION PROBLEM

In the TP, the problem of minimizing the total transportation costs is most often solved: resources, passengers, energy, information, etc., which in real conditions can represent a large expense for a certain economic system. Finding the optimal, i.e. the most economical transportation of a product in most cases involves finding such a plan for the transportation of one type of goods from the place of source to certain destinations [2]. At the same time, the criterion of minimizing the total costs is set, so that the best execution of the distribution of goods is achieved.

The task of the TP consists in determining the quantity of goods  $x_{ij}$  which from any point  $A_i, i=1,2,\dots,m$  should be transported to any point  $B_j, j=1,2,\dots,n$  provided that the total transportation costs are minimal. It is assumed that there is only one connection between the source  $A_i, i=1,2,\dots,m$  and the destination  $B_j, j=1,2,\dots,n$ . If transportation between  $A_i$

and  $B_j$  is prohibited for some reason, it is assumed that the price of transportation on that relation is  $c_{ij} = M$ , where  $M$  is an arbitrarily large constant. In that way, the transportation between the source  $A_i$  and the destination  $B_j$  will have an arbitrarily high price, so that route will not be the optimal solution.

The objective function is expressed through the total transportation costs that need to be minimized within the bounded set by the road network and available resources and can be represented numerically by the (1):

$$F = \sum_{i=1}^m \sum_{j=1}^n c_{ij} x_{ij} \rightarrow \min . \quad (1)$$

The set of TP bounded has  $m+n$  bounded, i.e. as many as there are production and consumption centers in total and can be written (2):

$$\sum_{j=1}^n x_{ij} = a_i , \quad (2)$$

where is  $i=1,2,\dots,m$  and  $x_{ij} \geq 0$ .

Solving the TP means setting the initial program, i.e. determining the routes by which the goods will be transported, in order to meet the needs of the destination while using the capacity of the source. The goal is to find a combination of resource allocation in which transportation costs will be minimal. In most cases, solving the TP begins with determining the basic solution, i.e. determining the initial solution using one of the known algorithms. Determining the initial solution is the first phase of solving the TP. In case the optimal solution is not obtained, we move to the second phase in which a series of iterations move from the initial solution to the basic solutions that are closer to the optimal solution [2].

There are several methods for obtaining an initial basic solution, such as the northwest angle method, the minimum cost method, Vogel approximate method, Vogel - Kordin procedure, New proximative method, Maximum allocation in demand method and other.

#### IV. ON SOLVING CAPACITATED TRANSPORTATION PROBLEM

The general transportation model consists of the target function, supply bounded, demand bounded and positive bounded. However, if the variables  $x_{ij}$  representing the quantities of the shipment have capacity limitations for various reasons, such as the capacity of the means of transportation, the capacity of the railway network, the capacity of the warehouse, etc. Then this is a specific case of a TP and it is called a TP with additional restrictions. In practice, such problems often occur, with unbalanced quantities of supply and demand. The transition from the open problem is the introduction of a fictitious source (supply) or destination (demand) with very high prices.

When solving the mentioned TP, the situation in the transportation company for the transportation of consumer goods can be considered, where there is a need for a certain amount of goods, which we call destinations and sources that represent storage places for a certain category of goods. However, the problem is also the possibility of means of transportation, i.e. the carrying capacity of goods from source and destination, which is an additional limitation that we call the limit from the top. Since the goal of each logistics or transportation task is to save human and material resources, it is necessary to consider the cost-effectiveness of using a means of transport on a particular line, i.e. it is necessary to define the minimum amount of goods needed to be transported to make use of means of economic viability and we call this the lower limit. If we look at Table I, we can see that it is a TP with an additional restriction, where there is only the upper restriction.

TABLE I. TRANSPORTATION PROBLEM WITH ADDITIONAL BOUNDED FROM ABOVE.

$S_i \backslash D_j$	$d_1$	$d_2$	...	$d_n$
$s_1$	$c_{11} \uparrow u_{11}$ $x_{11}$ $0$	$c_{12} \uparrow u_{12}$ $x_{12}$ $0$	...	$c_{1n} \uparrow u_{1n}$ $x_{1n}$ $0$
$s_2$	$c_{21} \uparrow u_{21}$ $x_{21}$ $0$	$c_{22} \uparrow u_{22}$ $x_{22}$ $0$	...	$c_{2n} \uparrow u_{2n}$ $x_{2n}$ $0$
...	...	...	...	...
$s_m$	$c_{m1} \uparrow u_{m1}$ $x_{m1}$ $0$	$c_{m2} \uparrow u_{m2}$ $x_{m2}$ $0$	...	$c_{mn} \uparrow u_{mn}$ $x_{mn}$ $0$

Obviously this is a linear programming task, which can be written mathematically [20]:

$$\min F = \sum_{i=1}^m \sum_{j=1}^n c_{ij} x_{ij} , \quad (3)$$

$$\sum_{j=1}^n x_{ij} = s_i , \quad (4)$$

where is  $i = 1, 2, \dots, m$  ,

$$\sum_{i=1}^m x_{ij} = d_j , \quad (5)$$

where is  $j = 1, 2, \dots, n$  ,

$$0 \leq x_{ij} \leq u_{ij} , \quad (6)$$

where is  $i = 1, 2, \dots, m ; j = 1, 2, \dots, n$ .

If is  $\sum_{i=1}^m s_i > \sum_{j=1}^n d_j$  it is an open problem, so a fictitious consumer is introduced  $D_{n+1}$  with

$$d_{n+1} = \sum_{i=1}^m s_i - \sum_{j=1}^n d_j , \quad (7)$$

and very high prices  $c_{i,n+1}$  ( $i = 1, \dots, m$ ). In this way, the closed transportation problem is obtained, and is mathematically represented by the following (8) and (9):

$$\min F = \sum_{i=1}^m \sum_{j=1}^{n+1} c_{ij} x_{ij} , \quad (8)$$

$$\sum_{j=1}^{n+1} x_{ij} = s_i , \quad (9)$$

where is  $i = 1, 2, \dots, m$  and apply (5) and (6).

However, the TP can be given with additional limitation from both the bottom and the top. This problem can be written in (3), (4) and (5), but in condition (10):

$$l_{ij} \leq x_{ij} \leq u_{ij} , \quad (10)$$

where is  $i = 1, 2, \dots, m ; j = 1, 2, \dots, n$ .

Whereat  $l_{ij} > 0$  represents the bounded of the variable  $x_{ij}$  from bottom, and  $u_{ij} > 0$  bounded from the top. It is assumed that this is a closed TP, i.e.  $\sum_{i=1}^m s_i = \sum_{j=1}^n d_j$  and that they are  $\sum_{i=1}^m l_{ij} \leq d_j$ ,  $\sum_{j=1}^n l_{ij} \leq s_i$ ,  $\sum_{i=1}^m u_{ij} \geq d_j$ ,  $\sum_{j=1}^n u_{ij} \geq s_i$ . TP (3), (4), (5) and (10) can be solved in following way:

$$\min F = \sum_{i=1}^m \sum_{j=1}^n c_{ij} x_{ij} + A, \quad (11)$$

$$\sum_{i=1}^m t_{ij} = s_i, \quad (12)$$

where is  $i = 1, 2, \dots, m$ ,

$$\sum_{j=1}^n t_{ij} = d_j, \quad (13)$$

where is  $j = 1, 2, \dots, n$ ,

$$0 \leq t_{ij} \leq u_{ij} - l_{ij}, \quad (14)$$

where is  $i = 1, \dots, m; j = 1, \dots, n$  and where is:

$$A = \sum_{i=1}^m \sum_{j=1}^n c_{ij} l_{ij}, \quad (15)$$

$$\hat{s}_i = s_i \sum_{j=1}^n l_{ij}, \quad (16)$$

$$\hat{d}_j = d_j - \sum_{i=1}^m l_{ij}. \quad (17)$$

Obviously, every derived value of  $t_{ij}$  from (2) corresponds to a value  $x_{ij} = t_{ij} + l_{ij}$  from (1), concerning, each value of  $x_{ij}$  from (1) corresponds to the derived value  $t_{ij} = x_{ij} - l_{ij}$  from (11). Each derived value of the goal function given by (1) is equal to the value of the goal function given by (11), i.e. a correspondence between the two specified expressions for the goal functions. Which means

that the TP given by (10) can be solved in the following (8) with constraints (5), (6) and (9).

Lemma [21]: Equation (8) with constraints (5), (6) and (9) is derived if and only if it holds:

$$\frac{s_i d_j}{d} \leq u_{ij}. \quad (18)$$

For  $(i = 1, \dots, m; j = 1, \dots, n)$ , where is:

$$d = \sum_{i=1}^m s_i = \sum_{j=1}^n d_j. \quad (19)$$

Transportation problem with additional limitation from both the bottom and the top as shown in Table II.

TABLE II. TRANSPORTATION PROBLEM WITH ADDITIONAL BOUNDED FROM THE TOP AND BOTTOM.

$D_j \backslash S_i$	$d_1$	$d_2$	...	$d_n$
$s_1$	$c_{11}$ $\uparrow u_{11}$ $x_{11}$ $\downarrow l_{11}$	$c_{12}$ $\uparrow u_{12}$ $x_{12}$ $\downarrow l_{12}$	...	$c_{1n}$ $\uparrow u_{1n}$ $x_{1n}$ $\downarrow l_{1n}$
$s_2$	$c_{21}$ $\uparrow u_{21}$ $x_{21}$ $\downarrow l_{21}$	$c_{22}$ $\uparrow u_{22}$ $x_{22}$ $\downarrow l_{22}$	...	$c_{2n}$ $\uparrow u_{2n}$ $x_{2n}$ $\downarrow l_{2n}$
...	...	...	...	...
$s_m$	$c_{m1}$ $\uparrow u_{m1}$ $x_{m1}$ $\downarrow l_{m1}$	$c_{m2}$ $\uparrow u_{m2}$ $x_{m2}$ $\downarrow l_{m2}$	...	$c_{mn}$ $\uparrow u_{mn}$ $x_{mn}$ $\downarrow l_{mn}$

TABLE III. EXAMPLE TRANSPORTATION PROBLEM WITH ADDITIONAL BOUNDED.

$D_j \backslash S_i$	41	26	23	40
36	8 $\uparrow 25$ $\downarrow 4$	6 $\uparrow 14$ $\downarrow 3$	10 $\uparrow 16$ $\downarrow 2$	9 $\uparrow 25$ $\downarrow 0$
51	9 $\uparrow 15$ $\downarrow 1$	12 $\uparrow 20$ $\downarrow 3$	13 $\uparrow 21$ $\downarrow 0$	7 $\uparrow 22$ $\downarrow 4$
43	14 $\uparrow 38$ $\downarrow 2$	9 $\uparrow 20$ $\downarrow 4$	16 $\uparrow 25$ $\downarrow 1$	5 $\uparrow 21$ $\downarrow 0$

Taking into account the derived (8) under the conditions defined in Lemma and since (8) is defined with constraints (5), (6) and (9), it can be concluded that there is at least one optimal solution. The paper discusses only the closed TP with additional capacity limitation in order to simplify the display. As with the general model of the TP, the starting point is the determination of the initial basic solution, where several

modifications of the mentioned methods will be presented on the example of the TP with an additional limitation given in Table III.

Solving the problem begins by calculating the following values  $u_{ij} - l_{ij}, s_i, d_j$ , based on (8) and (11). After the calculation, it can be seen that some of the additional restrictions are unnecessary, because they are already contained in other restrictions and they are eliminated in order to simplify Table IV.

TABLE IV. EXAMPLE REDUCED TRANSPORTATION PROBLEM WITH ADDITIONAL BOUNDED.

$D_j \backslash S_i$	34	16	20	36
27	8 ↑21	6 ↑11	10 ↑14	9 ↑25
43	9 ↑14	12	13	7 ↑18
36	14	9	16	5 ↑21

#### A. Modified Minimum Cost Method

This method is one of the most commonly used due to its simplicity and closer initial solution to the optimal one. However, the method itself in solving the problem with an additional constraint must be modified so that its algorithm consists of two phases [26].

**Phase 1:** The algorithm starts by defining the following values  $\hat{s}_i = s_i, \hat{d}_j = d_j$ .

**Step 1:** Select the cell  $(i, j)$  with the lowest unit price value in the existing table. If the selected price is not unique, then one is chosen arbitrarily and the variable gets the value

$$x_{ij} = \min \{ \hat{s}_i, \hat{d}_j, u_{ij} \} . \quad (20)$$

**Step 2:** It is established on the basis of which constraint the value of the variable  $x_{ij}$  is obtained on the basis of (12), due to which three possible cases are distinguished:

**I case:** if it is  $x_{ij} = \hat{s}_i \leq \{ \hat{d}_j, u_{ij} \}$ , then  $i$  - row does not consider further, because the offer is exhausted;

**II case:** if it is  $x_{ij} = \hat{d}_j \leq \{ \hat{s}_i, u_{ij} \}$ , then  $j$  - column does not consider further, because the demand is satisfied;

**III case:** if it is  $x_{ij} = u_{ij} \leq \{ \hat{s}_i, \hat{d}_j \}$ , then  $x_{ij}$

will be a non-basic variable with values of the upper limit of the limit, which will reduce the supply and demand for the value of the limit  $x_{ij}$ , concerning  $\hat{s}_i \rightarrow \hat{s}_i - x_{ij}, \hat{d}_j \rightarrow \hat{d}_j - x_{ij}$ . After that, the value for the newly acquired values of supply and demand is changed in the existing table and the procedure is repeated of Step 1.

**Step 3:** When one row or column remains at the end, all other variables are basic. There can be a total of  $m + n + 1$  basic variables.

**Step 4:** Assume it is the last remaining cell  $(k, l)$ , then  $x_{ij} = \min \{ \hat{s}_i, \hat{d}_j \}, (\hat{s}_k = \hat{d}_l)$

- If in one iteration both the row and the column are exhausted/ satisfied, then  $\hat{s}_i = \hat{d}_j = 0$ , then one of them is no longer considered. It would be good to keep a row or column that has a lower price  $c_{ij}$ .
- In case III, the calculation with  $\hat{s}_i$  and  $\hat{d}_j$  is repeated until one of them reaches the value zero.

**Phase 2:** Assume that  $x_{mn} > u_{mn}$ , which causes unfeasibility and we should throw  $x_{mn}$  out of the database. Then there is a unique cycle for the cell  $(m, n)$ , all angles of this cycle are basic except one. The values of the variables in this cycle are calculated for

$$\Delta = x_{mn} - u_{mn} , \quad (21)$$

according to the signs of the cells in the cycle (if the sign of the cell  $(m, n)$  is negative; the sign changes to positive for the neighboring cell and so on).

After calculating the table, if (6) is valid, the basic solution is reached, otherwise the mentioned process should be repeated.

After the realized iterations, the initial basic solution to the troubled TP, i.e. the value of the target function is  $\min F = 909$ , and can be written in the form given in Table V.



TABLE V. THE INITIAL SOLUTION TO THE TP WAS OBTAINED BY A MODIFIED MINIMUM COST METHOD.

$S_i \backslash D_j$	34	16	20	36
27	8 $\uparrow$ 21 <u>21</u>	6 $\uparrow$ 11 -	10 $\uparrow$ 14 <u>6</u>	9 $\uparrow$ 25 -
43	9 $\uparrow$ 14 <u>13</u>	12 <u>1</u>	13 <u>14</u>	7 $\uparrow$ 18 <u>15</u>
36	14 -	9 <u>15</u>	16 -	5 $\uparrow$ 21 <u>21</u>

### B. Modified New Approximate Method (NAM)

New approximation method is the method for finding the initial basic solution, which was first presented in 2013 in the journal Annals of pure applied mathematics. The research results have shown that this method provides permissible basic solutions to the TP that are very close to the optimal value [11]. The same can be applied to the TP with additional restrictions, with a slight change when determining the amount of goods to be allocated to the variable  $x_{ij}$ . Algorithm for modified NAM.

**Phase 1:** The algorithm starts by defining the following values  $\hat{s}_i = s_i, \hat{d}_j = d_j$ .

**Step 1:** The receiving station with the maximum demand is selected, and then the minimum price is found in the selected column and the maximum possible value of demand is assigned to it.

**Step 2:** A new table is formed, in the first column of which the receiving stations  $S_i$  are entered, and in the second column the dispatch stations  $D_j$ , which were identified in the previous step. A unique receiving station  $D_j$  is observed, which is assigned a minimum value of the available quantity of goods in the dispatch station  $s_i$  the required quantity in the receiving station  $D_j$  and the limit defined in the considered cell (20). The new value for the available quantity in the receiving station is obtained when the value assigned to the variable  $x_{ij}$  is subtracted from the existing value. If the available quantity in the receiving station is exhausted/satisfied, the corresponding column/row is eliminated, and if there is no

single receiving station  $D_j$ , proceed to the next step.

**Step 3:** If there is no single receiving station in the second column of the table  $B_j$ , then the sending stations that have the same receiving stations are selected. The differences between the two minimum prices  $c_{ij}$  for each row of observed receiving stations  $B_j$  in the transportation cost matrix are calculated.

**Step 4:** In this step, there is a dispatch station with the biggest difference. The variable  $x_{ij}$  is assigned the minimum value of the available quantity of goods in the dispatch station  $S_i$ , the required quantity in the receiving station  $D_j$  and the limit defined in the considered cell (20). If there are two or more stations with the same difference, then the difference between the minimum price and the next minimum price in the price matrix is determined for those dispatch stations. The dispatch station with the maximum difference is selected and the available quantity of goods (20) is assigned to the variable  $x_{ij}$ . If the available quantity in the dispatch/receiving station is exhausted/satisfied, the corresponding column/row is eliminated.

**Step 5:** Steps 3 and 4 are repeated until all quantities of goods from the dispatching stations to the receiving stations have been distributed.

**Phase 2:** When phase 1 is completed, if the condition  $x_{mm} < u_{mm}$  is satisfied, then it means that the initial basic solution is obtained, otherwise we move to phase 2 as with the modified lowest price method.

To show the practical solution of the TP, this method will use the example of the TP with an

TABLE VI. THE INITIAL SOLUTION OF THE TP OBTAINED BY THE MODIFIED NAM METHOD.

$S_i \backslash D_j$	34	16	20	36
27	8 $\uparrow$ 21 <u>16</u>	6 $\uparrow$ 11 <u>11</u>	10 $\uparrow$ 14 -	9 $\uparrow$ 25 -
43	9 $\uparrow$ 14 <u>14</u>	12 -	13 <u>14</u>	7 $\uparrow$ 18 <u>15</u>
36	14 <u>4</u>	9 <u>5</u>	16 <u>6</u>	5 $\uparrow$ 21 <u>21</u>

additional constraint given in Table III. The initial basic solution, i.e. the value of the target function is  $\min \min F = 901$  and can be written in the form given in Table VI.

### C. Modified Method Of Maximum Allocation In Demand

The method of maximum allocations was created within the research at the Center for Research in the Field of Defense Logistics of the University of Defense in Belgrade in 2017. The basic premise of this method is based on the consideration of maximum values in demand points and the allocation of resources that meet this condition. One of the main advantages of this method is its uniqueness and transportation plan, which in many cases is close to optimal [2]. Since the method itself is more recent due to its uniqueness in considering maximum values at demand points and allocating resources that meet this condition, a small modification will be made by considering the bounded that define individual variables, so that its algorithm consists of two phases.

**Phase 1:** The algorithm starts by defining the following values  $\hat{s}_i = s_i, \hat{d}_j = d_j$ .

**Step 1:** The receiving station with maximum demand  $d_j = \max\{d_j\}$  is selected, then the  $c_{ij} = \min\{c_{ij}\}$  for  $(i=1, \dots, m)$  is found in the selected column and assigned the maximum possible demand value, i.e. (20).

**Step 2:** If there are two receiving stations that require the same maximum value of goods, the receiving station with the lower price is selected. If even then there are two same receiving stations with the same minimum prices, the receiving station is selected where the difference between the minimum and the next minimum price is the largest. However, if the previous one is not fulfilled, the receiving station is selected where the sum of all prices in the observed column is higher.

**Step 3:** The row/column whose supply/demand is exhausted/satisfied is eliminated.

**Step 4:** The previous steps are repeated until all funds are allocated to the receiving stations.

**Phase 2:** If the condition  $x_{mn} < u_{mn}$  is satisfied after the end of phase 1, then it means that the initial basic solution is obtained,

otherwise we move to phase 2, which is identical to the modified lowest price method.

As in the previous methods, an example of a TP with an additional constraint given in Table II will be used to apply this method, and the initial basic solution is  $\min F = 884$  and can be written in the form given in Table VII.

TABLE VII. THE INITIAL SOLUTION TO THE TP WAS OBTAINED BY A MODIFIED METHOD OF MAXIMUM ALLOCATION IN DEMAND.

$S_i \backslash D_j$	34	16	20	36
27	8 $\uparrow$ 21 <u>16</u>	6 $\uparrow$ 11 <u>11</u>	10 $\uparrow$ 14 -	9 $\uparrow$ 25 -
43	9 $\uparrow$ 14 <u>18</u>	12 -	13 <u>10</u>	7 $\uparrow$ 18 <u>15</u>
36	14 -	9 <u>5</u>	16 <u>10</u>	5 $\uparrow$ 21 <u>21</u>

Using the simplex method for the example in Table III, the optimal solution  $\min F = 879$  was obtained, which is not quite far from the obtained initial solutions presented by the mentioned modified methods.

## V. CONCLUSION

A TP with additional bounded is a special case of linear programming. There are a number of methods used to arrive at an initial basic solution. The proposed modified methods for solving the TP with additional capacity bounded, in the examples shown with bounded from the top and bottom, provide an initial basic solution, which facilitates obtaining an optimal solution. However, the presented modification is not applicable to methods for obtaining optimal solutions in the TP, such as The potency method, i.e. the MODI method, Jumping from stone to stone, Ford Fulkerson methods, Methods of conditionally optimal plans and similarly.

Considering that the simple solution of the problem by the simplex method is extremely demanding and complicated, especially if it is a problem with several supply and demand stations and several additional restrictions, several different applications have been made to easily reach the optimal solution (LINGO, GAMS, SOLVER, WinQSB, etc.).

## ACKNOWLEDGMENT

This research was financially supported by the Ministry of Education, Science and Technological Development of the Republic of Serbia (Contract No. 451-03-68/2022-14/200109).

## REFERENCES

- [1] Stojiljković, M., & Vukadinović, S. (1984). Chapter 1. In *Operational research (Operaciona istraživanja)*. Belgrade: Military Publishing House.
- [2] Pamučar, D. (2017). Chapter 3. In *Operational research: deterministic methods and models (Operaciona istraživanja: determinističke metode i modeli)*. Belgrade: RABEK- European Center for Operational Research.
- [3] Kantorovič, L. V. (1939). *Mathematical methods in the organization and planning of production (Matematičke metode organizaciji planiranja proizvodstva)*. Leningrad
- [4] Hitchcock, F. L. (1941). The Distribution of a Product from Several Sources to Numerous Localities. *Journal of Applied Mathematics and Physics*, 40, 224-230.
- [5] Koopmans, T. C. (1947). Optimum Utilization of the Transportation System. *Econometrica*, 17, 136-146.
- [6] Dantzig, G. B. (1951). *Linear Programming and Extensions*. Princeton: Princeton University Press.
- [7] Reinfield, N.V. & Vogel, W.R. (1953). *Mathematical Programming. Englewood Cliffs*. New Jersey: Prentice Hall, (pp. 59-70).
- [8] Balakrishnan, N. (1990). Modified Vogel's approximation method for the unbalanced transportation problem. *Great Britain: Applied Mathematics Letters*, 3(2), 9-11.
- [9] Marković, D., Janošević, D., Jovanović, M., & Nikolić, V. (2010). Application method for optimization in solid waste management system in the city of Niš. *Facta Universitatis, series: Mechanical Engineering*, 8(1), 63–76.
- [10] Islam, A., Khan, A.R., Uddin M. S., & Malek M. A. (2012). Determination of Basic Feasible Solution of Transportation Problem: A New Approach. *Jahangirnagar University Journal of Science*, 35(1), 101–108.
- [11] Gaglani, M.S. (2013). A study of transportation problem, transshipment problem, assignment problem and supply chain management. PhD thesis. Saurashtra University, Department of Statistics.
- [12] Ezhil Vannan, S., & Rekha, S. (2014). A New Method for Obtaining an Optimal Solution for Transportation Problems. *International Journal of Engineering and Advanced Technology*, 2(5), 369-371.
- [13] Stojčić, M. (2018). Application of the ANFIS model in road traffic and transportation: A literature review from 1993 to 2018. *Operational research in Engineering Sciences: Theory and Applications (Oresta)*, 1(1), 40-61.
- [14] Petrović, G., Mihajlović, J., Čojbašić, Ž., Madić, M., & Marinković, D. (2019). Comparison of three fuzzy MCDM methods for solving the supplier selection problem. *Facta Universitatis, Series: Mechanical Engineering*, 17(3), 455-469.
- [15] Karagul, K., & Sahin, Y. (2020). A novel approximation method to obtain initial basic feasible solution of transportation problem. *Journal of King Saud University-Engineering Sciences*, 32(3), 211-218.
- [16] Amaliah, B., Faticah, C., & Suryani, E. (2020). A new heuristic method of finding the initial basic feasible solution to solve the transportation problem. *Journal of King Saud University-Computer and Information Sciences*.
- [17] Hussein, H. A., Shiker, M. A., & Zabiba, M. S. (2020, July). A new revised efficient of VAM to find the initial solution for the transportation problem. In *Journal of Physics: Conference Series*, 1591(1), 012032.
- [18] Mathirajan, M., & Rani, M. V. (2021). Observations on new initial basic feasible solution (IBFS) Methods published in the literature for transportation problem. In *Proceedings of the International Conference on Industrial Engineering and Operations Management. IEOM Society* (pp. 201-210).
- [19] Mathirajan, M., Reddy, S., & Rani, M. V. (2022). An experimental study of newly proposed initial basic feasible solution methods for a transportation problem. *OPSEARCH*, 59(1), 102-145.
- [20] Jain, S., & Arya, N. (2013). An Inverse Capacitated Transportation Problem. *IOSR Journal of Mathematics*, 5(4), 24-27.
- [21] Zheng, H. R., Xu, J. M., & Hu, Z. M. (1994). Transportation problems with upper limit bounded on the variables and with parameters. *Journal of Wuhan university natural science edition*, 5, 1-5.
- [22] Rachev, S. T., & Olkin, I. (1999). Mass transportation problems with capacity bounded. *Journal of applied probability*, 36(2), 433-445.
- [23] Dahiya, K., & Verma, V. (2007). Capacitated transportation problem with bounds on rim conditions. *European journal of operational research*, 178(3), 718-737.
- [24] Bazaraa, M. S., Jarvis, J. J., & Sherali, H. D. (2010). Chapter 3. *Linear programming and network flows*. New Jersey: John Wiley & Sons, (4th ed.).
- [25] Acharya, D. (2016). Generalized solid capacitated transportation problem. *South Asian Journal of Mathematics*, 6(1), 24-30.
- [26] Ahmadi, K. (2018). On Solving Capacitated Transportation Problem. *Journal of Applied Research on Industrial Engineering*, 5(2), 131-145.

# Using the MCDM Approach to Evaluate Smart and Sustainable Cities

Ibrahim Badi<sup>1</sup>, Željko Stević<sup>2</sup>, Muhammad Lawan Jibril<sup>3</sup>

<sup>1</sup>Libyan Academy, Mechanical Engineering Department, Libya

<sup>2</sup>University of East Sarajevo, Faculty of Transport and Traffic Engineering, Dobož, Bosnia and Herzegovina

<sup>3</sup>Federal University of Kashere, Mathematics and Computer Science Department, Gombe, Nigeria

<sup>1</sup>i.badi@lam.edu.ly, <sup>2</sup>zeljkostevic88yahoo.com, <sup>3</sup>mljtech@gmail.com

**Abstract**—Cities are undergoing significant transformations to become smarter and more sustainable. Therefore, utilizing evaluation frameworks, it is necessary to compare these efforts. Different criteria can be used to evaluate smart cities. In this research, the weighting of smart and sustainable city criteria is done using the Full Consistency Method (FUCOM). The findings show that while smart economy is the most crucial quality with a priority of 35.4%, smart governance comes in last with a priority of 5.7%. MARCOS method is used to make comparisons between five cities in North Africa. Rabat and Cairo are the top two cities overall, according to the analysis developed. The article's findings are intended to assist cities in understanding how they compare to other cities and to identify areas where authorities need to make improvements.

**Keywords** - Smart cities, MCDM, FUCOM, MARCOS

## I. INTRODUCTION

Due to its scale and complexity, the idea of a sustainable and smart city is one of the crucial issues in today's public policy. Since the start of the twenty-first century, the “smart and sustainable city” movement, which first gained popularity in the 1990s, has been slowly growing in acceptance. Approximately 80% of the global GDP is produced by the big cities. Additionally, they use 80% of the energy produced worldwide and are responsible for at least 70% of carbon emissions [1].

By 2050, the United Nations Population Fund predicts that 70% of the world's population will reside in urban areas. There are currently 828 million people living in substandard housing, and this number is continuously rising. Cities' development, planning, and management are complicated by these issues. Therefore, when creating their action plans, city and nation managers need to think of clever ways to improve their cities' economic activity, energy consumption, environmental circumstances, and quality of life. Because they offer services using ICT infrastructure, many cities are referred to as smart cities. Building sustainable and smart cities also entails providing its citizens with satisfying and adaptable job and business opportunities, secure and cheap housing, a more democratic society, open governance, and a successful economy. Additionally, it entails funding public transportation, expanding the amount of green space, and undertaking urban planning and governance using methods that encourage participation from all citizens.

## II. METHODOLOGY

Multi-criteria decision-making techniques are now being used more often. There have been numerous approaches developed recently and they are applied in numerous applications [2]. In this study, a hybrid model that combines the FUCOM- MARCOS methods will be applied. The weights of the criteria will be determined using the FUCOM approach, and the MARCOS method will be used to rank the cities.

One of the most recent MCDM models was developed by Pamuar et al. (2018) and is called FUCOM. This method employs the pairwise comparison strategy [3]. Compared to other MCDM methods like the Best Worst Method (BWM) and the Analytical Hierarchy Process (AHP), it necessitates fewer pairwise comparisons [4]. Additionally, it has the ability to validate results by defining the comparison's deviation from maximum consistency (DMC) and locating transitivity in paired criteria comparisons.

Assume that there are ( $n$ ) criteria to be analyzed. Each of these criteria must be given a weight in order for the decision-maker to establish its significance. The impact of each criterion  $I$  on the other criterion ( $j$ ) is identified in pairwise comparison models. The steps listed below can serve as an example of the FUCOM approach:

Step 1: Expert ranking of criteria/sub-criteria.

Step 2: Determining the vectors of the comparative significance of evaluation criteria.

Step 3: Establishing the constraints of a model for nonlinear optimization.

Constraint 1: The relative relevance of the specified criteria is indicated by the percentage of weight coefficients.

Constraint 2: The number of weights must satisfy the transitivity condition of mathematical model.

Step 4: Calculating the final weights of assessment criteria.

Step 5: Calculating the final weights of sub-criteria for appraisal.

The MARCOS technique is built on specifying how alternatives and reference values relate to one another (ideal and anti-ideal alternatives). Utility functions are used to define decision-making preferences. The location of an alternative in regard to the ideal and anti-ideal solutions is referred to as its utility function. The best solution is the one that is farthest from the anti-ideal point and the ideal point. It was developed by Stevic et al. in 2020 [5]. The methods' steps can be summarized as follows [6]:

Step 1. Creating the initial decision matrix.

Step 2. The development of an extended initial matrix. The ideal and anti-ideal solutions are defined in this step. The ideal solution is an

alternative with the best alternative for certain criteria, whereas the anti-ideal solution is the worst alternative for certain criteria. This is based on the following equations:

$$AAI = \min_i x_{ij} \quad \text{if } j \in B \quad \text{and} \quad (1)$$

$$\max_i x_{ij} \quad \text{if } j \in C$$

$$AI = \max_i x_{ij} \quad \text{if } j \in B \quad \text{and} \quad (2)$$

$$\min_i x_{ij} \quad \text{if } j \in C$$

where  $B$  represents the criterion that should be maximized and  $C$  represents the criterion that should be minimized.

Step 3: The initial matrix is normalized in step three. The following equations are used for normalization:

$$n_{ij} = \frac{x_{ai}}{x_{ij}} \quad \text{if } j \in C \quad (3)$$

$$n_{ij} = \frac{x_{ij}}{x_{ai}} \quad \text{if } j \in B \quad (4)$$

where the elements and represent the elements from the initial decision matrix.

Step 4. The weighted matrix is determined in this step. Weighting is performed by multiplying normalized matrix values by corresponding weights.

Step 5. This step involves the calculation of the utility degree of the alternatives  $K_i$ . The utility degree is determined by applying the following equations:

$$K_i^- = \frac{S_i}{S_{aai}} \quad (5)$$

$$K_i^+ = \frac{S_i}{S_{ai}} \quad (6)$$

where  $i = 1, 2, \dots, m$  represents the sum of the elements of a difficult matrix:

$$S_i = \sum_{j=1}^n v_{ij} \quad (7)$$

Step 6. The formation of the utility function of the alternatives  $f(K_i)$ . The utility function is calculated by using the following equation:

$$f(K_i) = \frac{K_i^+ + K_i^-}{1 + \frac{1 - f(K_i^+)}{f(K_i^+)} + \frac{1 - f(K_i^-)}{f(K_i^-)}} \quad (8)$$

where  $f(K_i^-)$  is the utility function versus the anti-ideal solution, while  $f(K_i^+)$  is the utility function versus the ideal solution. The utility functions are calculated by using the following equations:

$$f(K_i^-) = \frac{K_i^+}{K_i^+ + K_i^-} \quad (9)$$

$$f(K_i^+) = \frac{K_i^-}{K_i^+ + K_i^-} \quad (10)$$

Step 7. Ranking the alternatives. A rank is formed based on the final value of the utility function. It is desirable that the alternative should have the greatest value of the utility function.

### III. CASE STUDY

The concept of smart cities is still weak in most developing countries. However, there are some indicators that can be measured in these countries. In this study, the capitals of five North African countries will be compared: Rabat, Cairo, Tunisia, Tripoli, and Algeria. Seven criteria were used for the purpose of comparing these capitals, which are: Smart economy (C1), Smart environment (C2), Smart governance

(C3), Smart living (C4), Flexibility of labor market (C5), Innovative spirit (C6), and Productivity (C7).

Step 1. The decision on the ranking of the criteria is made as follows:  $C1 > C4 > C2 > C6 > C5 > C7 > C3$ .

Step 2. The decision-maker performs a pairwise comparison of the rating parameters. The comparison is done in comparison to the first ranked criterion. Therefore, the priority of the criteria ( $\varpi_{C_j(k)}$ ) were determined for all of the first-level criteria. (Table I).

TABLE I. CRITERIA PRIORITIES

Criteria	C1	C4	C2	C6	C5	C7	C3
$(\varpi_{C_j(k)})$	1	2	2.5	3	4.5	5	6

The comparative priorities of the criteria are determined using the obtained priorities of the criteria:

$$\begin{aligned} \varphi_{C_1/C_4} &= 2.0/1.0 = 2.0, \quad \varphi_{C_4/C_2} = 2.5/2.0 = 1.25, \\ \varphi_{C_2/C_6} &= 3.0/2.25 = 1.33, \quad \varphi_{C_6/C_5} = 4.5/3.00 = 1.50, \\ \varphi_{C_5/C_7} &= 5.0/4.5 = 1.11, \quad \varphi_{C_7/C_3} = 6.0/5.0 = 1.20 \end{aligned}$$

The final values of the weight constants and DFC of the results are established as  $as = 0.0$  after solving the model using MS Excel's solver and utilizing the values of the criteria marks provided. Fig. 1 shows that the first criterion, the smart economy, was the most important. The fourth criterion, demonstrated by the smart living, is also important. The aforementioned two criteria account for approximately fifty percent of the total weights of the criteria.

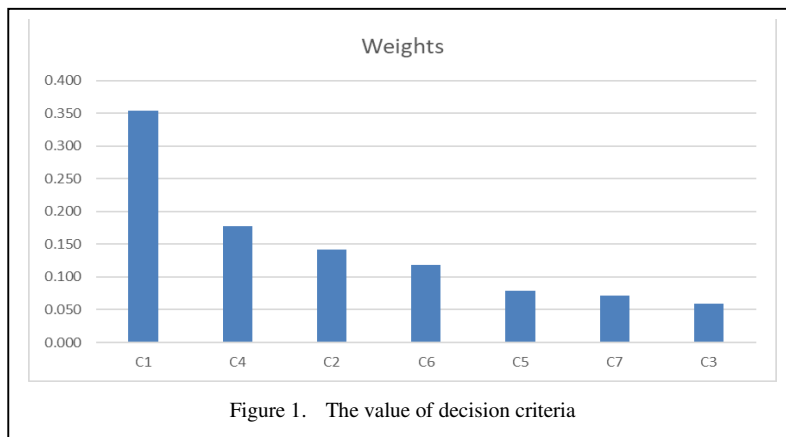

Figure 1. The value of decision criteria

After the weights of the criteria have been calculated, the five cities will now be ranked according to these criteria. Based on the opinions

of the experts, an initial decision matrix was initiated (Table II).

TABLE II. THE INITIAL DECISION MATRIX

Weights	0.354	0.142	0.059	0.177	0.079	0.118	0.071
Impact	C1	C2	C3	C4	C5	C6	C7
A1	72	78	75	65	80	70	78
A2	68	77	70	65	82	75	80
A3	65	78	70	60	80	68	75
A4	45	50	50	50	60	50	50
A5	55	60	65	65	70	68	70
MAX	72	78	75	65	82	75	80

Then, the data are normalized. Simple linear normalization is used for the normalization.

Since all criteria are of the benefit type, their maximum value is computed (Table III).

TABLE III. THE NORMALIZED DECISION MATRIX

Cities	C1	C2	C3	C4	C5	C6	C7
A1	1.000	1.000	1.000	1.000	0.976	0.933	1.040
A2	0.944	0.987	0.933	1.000	1.000	1.000	1.067
A3	0.903	1.000	0.933	0.923	0.976	0.907	1.000
A4	0.625	0.641	0.667	0.769	0.732	0.667	0.667
A5	0.764	0.769	0.867	1.000	0.854	0.907	0.933

The aggregated values are then calculated using the weighting coefficients. The following step involves calculating the utility degree. Prior to carrying out this step, it was necessary to identify the ideal and non-ideal solutions. Anti-ideal values represent the minimum value of a

particular criterion, whereas the ideal solution represents the maximum value. Then, the utility degrees were computed by adding the values for the individual alternatives, the ideal and anti-ideal solutions, and the anti-ideal solution (Table IV).

TABLE IV. THE WEIGHTED NORMALIZED DECISION MATRIX AND THE NEGATIVE-IDEAL SOLUTION

Cities	C1	C2	C3	C4	C5	C6	C7
A1	0.354	0.142	0.059	0.177	0.077	0.110	0.074
A2	0.334	0.140	0.055	0.177	0.079	0.118	0.076
A3	0.320	0.142	0.055	0.163	0.077	0.107	0.071
A4	0.221	0.091	0.039	0.136	0.058	0.079	0.047
A5	0.270	0.109	0.051	0.177	0.067	0.107	0.066
Ideal	0.354	0.142	0.059	0.177	0.079	0.118	0.076
Anti ideal	0.221	0.091	0.039	0.136	0.058	0.079	0.047

Forming the utility function of the alternatives was the sixth step of the MARCOS methodology. The utility function has been determined. To calculate the utility function of the alternatives, the utility function in relation to

the ideal and anti-ideal solutions had to be calculated. Incorporating these values produced the final value for the alternatives (Table V) and determined the cities' ranking.

TABLE V. THE RELATIVE ASSESSMENT MATRIX AND THE ASSESSMENT SCORES OF ALTERNATIVES

Measure	$K_i^-$	$K_i^+$	F(ki)	Rank
A1	1.479	0.988	0.780	<b>1</b>
A2	1.458	0.975	0.769	<b>2</b>
A3	1.392	0.931	0.734	<b>3</b>
A4	1.000	0.668	0.527	<b>5</b>
A5	1.263	0.844	0.666	<b>4</b>

The results show that the city of Rabat ranks first in terms of smart city evaluation, followed by Cairo. In last place comes the Libyan city of Tripoli.

#### IV. CONCLUSION

To increase the sustainability, productivity, and quality of life of their cities, governments and politicians are looking for new investment opportunities and policy areas. According to diverse interpretations of the term “smart and sustainable city,” numerous assessment techniques and indexes have been created. City managers and officials are showing a lot of interest in evaluation systems using quantitative data. They can choose where to spend their time and money as a result. The methodology used in this research resulted in a useful comparison of the cities. Each assessment offers very valuable

data along with the outcomes that may be applied to raise cities' performance.

#### REFERENCES

- [1] Ozkaya, G., & Erdin, C. (2020). Evaluation of smart and sustainable cities through a hybrid MCDM approach based on ANP and TOPSIS technique. *Heliyon*, 6(10), e05052.
- [2] Badi, I., & Kridish, M. (2020). Landfill site selection using a novel FUCOM-CODAS model: A case study in Libya. *Scientific African*, 9, e00537.
- [3] Pamučar, D., Stević, Ž., & Sremac, S. (2018). A new model for determining weight coefficients of criteria in mcdm models: Full consistency method (fucom). *Symmetry*, 10(9), 393.
- [4] Badi, I., Muhammad, L. J., Abubakar, M., & Bakır, M. (2022). Measuring Sustainability Performance Indicators Using FUCOM-MARCOS Methods. *Operational Research in Engineering Sciences: Theory and Applications*, 5(2), 99-116.
- [5] Stević, Ž., Pamučar, D., Puška, A., & Chatterjee, P. (2020). Sustainable supplier selection in healthcare industries using a new MCDM method: Measurement of alternatives and ranking according to COmpromise solution (MARCOS). *Computers & Industrial Engineering*, 140, 106231.
- [6] Badi, I., & Pamucar, D. (2020). Supplier selection for steelmaking company by using combined Grey-MARCOS methods. *Decision Making: Applications in Management and Engineering*, 3(2), 37-48.





# Multimedia Systems in Education

Marko Marković<sup>1</sup>, Neda Ilić<sup>1</sup>, Ana Kresović Kolundžić<sup>1</sup>, Maja Đurović-Petrović<sup>2</sup>, Jasmina Lozanović<sup>3</sup>

<sup>1</sup>Faculty of Applied Management, Economics and Finance – Belgrade, University Business Academy in Novi Sad, Serbia

<sup>2</sup>Innovation Center of the Faculty of Mechanical Engineering, University of Belgrade, Belgrade, Serbia

<sup>3</sup>Institute of Health Care Engineering with European Testing Center of Medical Devices, Graz University of Technology, Graz, Austria

<sup>3</sup>j.lozanovicsajic@tugraz.at; <sup>3</sup>jasmina.lozanovic@gmail.com

**Abstract—** This paper provides an overview of multimedia systems used in education. The advantages and disadvantages of multimedia systems for educational purposes are presented. In addition, multimedia applications used in virtual teaching and software for keeping pedagogical records are shown. The paper also contains an empirical study conducted among high school and university students that shows their evaluations of distance learning.

**Keywords** - multimedia systems, education, distance learning

## I. INTRODUCTION

The influence of the current world situation leaves a significant mark in the sphere of education and fundamentally changes the approach to learning and conceptualizing the way and type of teaching itself. We are witnessing sudden changes in the education system at all levels, and we are trying every day to overcome the steps to make the most of all available resources. Today, multimedia systems are used more and more in distance learning, and this is not about the situation but about the very way of global change in the education system, which provides lecturers and students with a range of additional opportunities, but also makes it challenging to work in some environments. The system is based on the exchange of multimedia content that contains large amounts of material for the adequate education of students. Models vary depending on the ability of the lecturer and the ability of the student. Since the 21st century has still not managed to connect

every inhabitant of this planet to the Internet, a problem arises in communication, where solutions are found in various ways. “Zapad” was the first to start with these systems and, through various studies, brought results that were more than excellent for that time, but the educators somehow did not like it, not because of the way of teaching, but because of the inexperience of the lecturers in new technologies. According to Perraton, this type of learning is also called free learning, using computers, the Internet, and other multimedia accessories for learning at home.

Learning is organized as a dialogue process in virtual classrooms, and this means the separation of the mentor from the student in space and (or) time [1].

As a whole in the education system, electronic learning includes the following items that distinguish it from the traditional way of teaching:

- distance between lecturer and student;
- structure and goal of the program being studied;
- content required for teaching;
- system of legal valuation prescribed by the Rulebook.

As this type of learning becomes a problem due to individuals who make a big difference between this way of learning and the traditional one and make bad comments, a specific rulebook is prescribed that defines the classification,

division, method, and teaching model. As multimedia is the future, experts rely on it and use all resources to improve teaching methods. The scope of learning levels, assessment methods, evaluation, and teaching accreditation are set. The professor's activity contributes to the organization of the content, and the dedication to making presentations, videos, tasks, and multimedia supplements, awakens the student in the knowledge that the lecturer cares that he acquires that knowledge.

The solutions to this type of learning can be divided and classified as follows:

- electronic books;
- educational programs;
- online courses;
- web platforms.

## II. ADVANTAGES AND DISADVANTAGES

The advantage is reflected in the flexibility of professors and students, and through activity and up-to-dateness, specific content can be viewed more than once, which makes it easier for students to master the material. The advantage is reflected in the possibility that students can study from their residence without going to another city or country, which leads to lower costs and the possibility that the student can work while studying. One of the most important advantages is the possibility that students who have a severe illness or some form of disability can follow lectures and exercises. A higher level of organization of the time spent on responsibilities related to lectures, choosing one's pace of learning, and taking exams. Another great advantage is that students can choose courses and programs as they wish, choose lecturers and the method of delivery, and the student can attend some prestigious and high-quality courses that are not from their country. The choice defines the level of interaction, from which students can choose classic written interaction, where students extract notes from the text of the presentation, interact with lecturers and colleagues via web applications, or even learn through modern multimedia systems that provide quality information in addition to quality graphics and sound. Through multimedia applications, students can acquire practical skills and all necessary knowledge through various simulations.

Disadvantages are considered to be that for this type of teaching, each participant must have basic knowledge of using computers and the Internet for learning purposes. Without specific knowledge, students will not be able to use the material they receive acceptably. In addition to all the knowledge, it is necessary to have better equipment for learning, which implies better computer specifications that will run various multimedia content. In addition, a high-quality Internet connection is required, which causes up to 80% of technical problems due to classes and inconvenience due to tests. Furthermore, an Internet connection reduces the student's concentration and creates additional pressure - deciding more independently how and when learning brings greater responsibility to students. Sometimes the credibility of the student's work is also a disadvantage because, without additional applications, the professor has no insight into whether the student has used the Izora when preparing for exercises or exams.

## III. MULTIMEDIA APPLICATIONS FOR LEARNING

For such a system to function, various supports are needed in the form of various applications, programs, and accessories that facilitate communication in the quality of teaching. The Internet is full of various systems, applications, and services for transferring knowledge, but a few fulfill all the technical aspects of an educational application. The Senate of the University of Serbia decided to conduct classes with the help of distance learning systems and with the help of web applications for meetings. Each higher education unit has its own platform solely due to work efficiency and the number of students who access the content simultaneously.

A multimedia system is a system capable of processing multimedia data and applications. The primary function of multimedia systems is processing, storing, producing, manipulating, and displaying multimedia information. A multimedia system is a computer that combines the application of telecommunications, image, sound, and video sequences [2].

The most frequently used online learning platforms are:

- Moodle;
- Zoom;
- Google Classroom;

- Google Meet;
- Microsoft Teams.

Certain higher education institutions independently develop platforms for distance learning.

#### IV. VIRTUAL TEACHING

In addition to traditional teaching, there is also virtual teaching, which awakens the desire for progress and knowledge acquisition in students. It is often a combination of state-of-the-art multimedia systems that give the impression that students are dealing with a topic in real time that students can only look at in books. American studies have shown that the feeling of learning is more awakened in young children through interactive teaching. The level of student knowledge is also based on the visual power of observation, where through various simulations, the student has the opportunity to, for example, be present in rare situations such as the launch of a rocket. A virtual classroom is a teaching environment that resides in a computer-generated communication support system. It is not built of steel and concrete but consists of a set of communication groups and workspaces with complex software.

Interactive whiteboards have been on our market for many years and have found their place in the educational system. Currently, not many schools have them, but the trend of their use is increasing. On the other hand, teachers worldwide have different opinions about using interactive whiteboards, and discussions about their effectiveness have been going on for some time. Then we mentioned the factors that affect the effectiveness of interactive whiteboards and accompanying teaching materials. We also talked to several teachers and asked them to share their skills and experience using interactive whiteboards. Publishers quickly recognized the potential of interactive whiteboards and created interactive textbooks. Today on our market, as additional textbooks, we can find interactive textbooks for learning foreign languages from foreign publishing houses. Teaching materials in foreign languages usually contain many exercises, so the accompanying software of the interactive whiteboard also contains additional video material that helps the teacher's work.

#### V. EMPIRICAL RESEARCH

The research aims to examine high school students and students about the use of online

learning platforms and to evaluate the effectiveness of online learning platforms.

High school students and students from Belgrade, Valjevo, and Novi Sad participated in the research.

The sample consists of 128 respondents, of which 99 and 29 high school students were randomly selected from all years of education online via Google questionnaire.

This research had the following tasks:

- Determine whether high school students and students consider multimedia educational platforms beneficial and to what extent;
- Determine which platforms we are talking about;
- Determine whether high school students and students are for online or traditional teaching methods;
- Determine with what grade high school students and students evaluate the online teaching model.

#### VI. RESULTS

Based on a sample of 128 students, we can conclude that 85.9% consider platforms to support distance practical learning. However, analyzing the answers, 18 respondents expressed that they were not satisfied with learning support platforms: a group of first-year high school students (12) and a group of first-year college students (6). From this analysis, we conclude that online platforms to support distance learning are helpful to a large extent.

Utility platforms for online learning are given in Fig.1. More than 85% of students consider distance learning platforms beneficial.

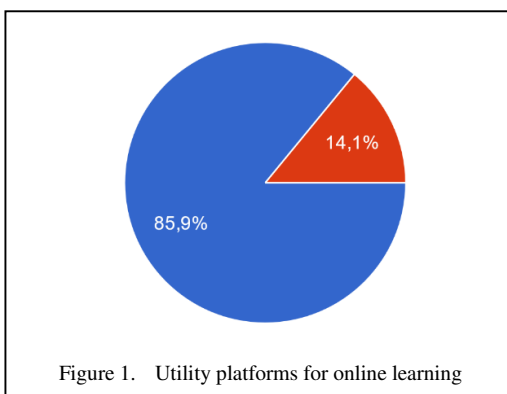

Figure 1. Utility platforms for online learning

The next item was an examination of which platforms we are talking about, and the results show platforms that we have processed to a large extent, and of course, there are other multimedia sources. For example, the diagram shows that Google Meet, Google Classroom, Zoom, and the Moodle platform are used to a large extent. In addition to them, there is also the Microsoft Teams platform, and finally, to a minor extent, there is the BigBlueButton platform, which achieved its success when it offered its services to the Moodle platform. This analysis concludes that standard and well-known platforms are in use.

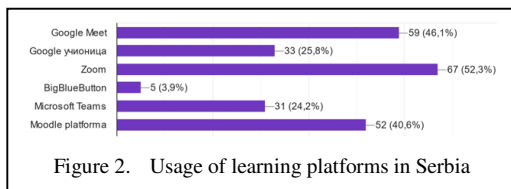

Figure 2. Usage of learning platforms in Serbia

The crucial part of the research was asking the respondents about the teaching method, we know that everyone wants to follow live teaching, but this is less and less possible due to the current situation. Of course, no platform can replace the live words of the lecturer, but the respondents' answers are different from our expectations. In fact, 43% of them think that the online form of teaching is good and that it is not a problem for them. This part includes students in the faculty's third and fourth year, for whom it is a well-known concept, while the rest of 57% is represented by high school students and first and second-year students.

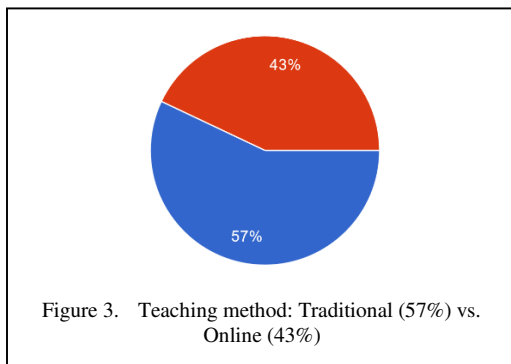

Figure 3. Teaching method: Traditional (57%) vs. Online (43%)

The last and most crucial segment of the research allows us to see how satisfied students are with online teaching. The results are mixed, but the highest percentage of responses ranges between 3 and 5, which is extremely good.

The grade itself is based on the entire lesson, where there are problems with the lecturer. The problems with the lecturers are that most of the

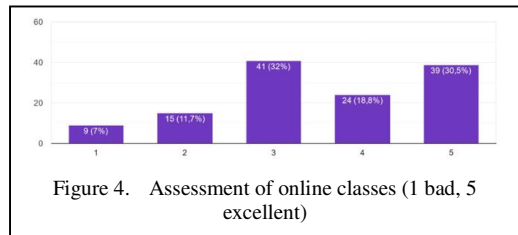

Figure 4. Assessment of online classes (1 bad, 5 excellent)

lecturers are senior professors and are not well versed in this work system, so there is a big problem with the implementation of the teaching itself. Great efforts are needed from both sides to improve the quality of teaching itself.

## VII. CONCLUSIONS

Based on the given research, we can conclude that despite all the circumstances, pupils and students support this type of teaching. It is expected that it is difficult for everyone in the beginning because they come across something utterly unknown until now. It takes a lot of patience, effort, and work to achieve great results.

The modern approach to teaching brings us one step closer to the digital revolution, and if nothing else, it encourages us that perhaps with our changes, we can participate in improving this type of teaching.

When compared to traditional teaching, teaching in a multimedia setting has a much greater positive impact on academic achievement and makes the material to be learned much easier to understand [11].

Nowadays, education has progressed in many segments, but there are still problems that can be solved by using new technologies. Education has a more challenging time accepting new and modern ways of education due to the high prices of multimedia equipment. The prices of computers and equipment prevent the teaching staff from delivering the material in the best and most efficient way possible. Although in our country, there is progress in that sphere, on the initiative of the Ministry of Education, Science and Technological Development, numerous projects of digitalization of schools have been launched. Sustainability is reflected in the implementation of dozens of digital classrooms to improve educational content.

We can conclude that it is necessary to use modern educational tools and technologies as much as possible in the teaching process. Using new modern technologies contributes to greater

motivation and engagement of students, which achieves a better way of acquiring and acquiring knowledge.

#### REFERENCES

- [1] Perraton, H (1988). *Theory and Distance Education*, . Taylor & Francis Group.
- [2] Korać, M. (2014). *Multimedija u obrazovanju*, FTN Čačak.
- [3] S. Ivanov, D. Stanujkić, & B. Đorđević. (2014). *Primena multimedije u savremenom obrazovanju*, Megatrend Univerzitet, Beograd.
- [4] Pedagoško društvo Srbije, (2022). Available at: [www.pedagog.rs](http://www.pedagog.rs)
- [5] PC Press, (2022). Available at: [pcpress.rs/zoom-za-velike-sastanke/](http://pcpress.rs/zoom-za-velike-sastanke/)
- [6] SMARTILIFE, (2002). Available at: [smartlife.mondo.rs/tech](http://smartlife.mondo.rs/tech)
- [7] Digitalna NBS, (2022). Available at: [digitalna.nb.rs](http://digitalna.nb.rs)
- [8] Google for Education, (2022). Available at: [edu.google.com](http://edu.google.com)
- [9] Virtuelna ucionica, (2022). Available at: [virtuelnaucionica.com](http://virtuelnaucionica.com)
- [10] E-Uprava, (2022). Available at: [euprava.gov.rs](http://euprava.gov.rs)
- [11] Bulut, R. (2019). An Analysis of The Effects of Multimedia Teaching on Student Achievement. *International Journal of Progressive Education*, 15(1), 1-22. doi: 10.29329/ijpe.2019.184.1



# Mitigating COVID-19 Crisis Effects in SMEs by Knowledge Management

Ivana Marinović Matović<sup>1</sup>, Anđela Lazarević<sup>2</sup>

<sup>1</sup>PUC Parking Service, Niš, Serbia

<sup>2</sup>University of Niš, Faculty of Mechanical Engineering, Niš, Serbia

<sup>1</sup>ivana.m.matovic@gmail.com, <sup>2</sup>andjela.lazarevic@gmail.com

**Abstract**—The contemporary environment is characterized by globalization, constant and rapid changes, a high degree of automation and digitization, innovation and creativity. In such conditions, the crisis causes unpredictable threats and dangers at the national, local and organizational level. The outbreak of COVID-19 crisis presented an unpredictable threat with a high degree of uncertainty. The implications of COVID-19 crisis on SME companies were very pronounced, especially considering that these companies generally do not have crisis management strategy. One of the characteristics of SMEs, insufficient knowledge and skills of entrepreneurs, further threatened their survival and sustainable development in COVID-19 conditions. This paper analyzes some of the possible measures to preserve the business continuity of SMEs, which are reflected in adequate knowledge management, especially emphasized in COVID-19 crisis conditions.

**Keywords** – SME, knowledge management, crisis management, COVID-19, entrepreneurship

## I. INTRODUCTION

Crises pose a social threat on a global, national and local level, and affect people's lives, their property and society as a whole. Crises are characterized by numerous features and events that occur violently, complexly and surprisingly, with high speed, and a lack of real information, which causes confusion and fear [1,2].

The frequency, nature and consequences of crises at the global level are constantly changing [3-5], which is a challenge for political and administrative structures. Crises pose a threat to human lives, the basic values of

society or the functioning of the system, which must be urgently addressed, in conditions of great uncertainty [6]. Society, organizations and individuals face a rapidly changing environment, affected by complex problems and difficulties [7].

Numerous theorists have tried to define the concept of crisis [8-10]. There are various definitions in the scientific literature, which are determined on the basic features of the crisis and their consequences. Reference [11] defines the crisis as a great threat, without enough time for response. Reference [12] emphasizes that the basic features of the crisis are low probability, high impact and threat to the basic goals. Reference [13] considers the crisis to be a sudden threat to priority objectives, with limited response time. Reference [14] has found that the crisis is an unexpected threat of great uncertainty, which requires urgency in decision-making. Reference [15] bases the definition of a crisis on the low probability of occurrence, ambiguous circumstances, which is a surprise and requires a quick decision to improve the situation. Reference [16] defines a crisis as an unusual event of high level of uncertainty that poses a threat.

Summarizing the above theoretical views reveals a common definition of the concept of crisis. The crisis is a sudden unpredictable problem, which must be solved immediately; a crisis is an event with great impact, which requires making critical decisions in conditions of uncertainty. Although the definitions may differ, the crisis is seen as a potential serious system threat, an unpredictable event, which places non-standard demands on the organization and the individual. In these



circumstances, critical decision making requires adequate knowledge, and real challenge is to identify knowledge necessary to make the right decisions, followed by the acquisition of this knowledge. This paper is aimed to enhance critical decision making by providing guidelines and measures to improve the SMEs body of knowledge, which is necessary for the establishment of the adequate knowledge management in company.

## II. CRISIS TYPES AND CRISIS CAUSES

Numerous theorists categorize crises, some divide them according to their character or process of formation; others classify them according to their cause or source; or crises are sorted according to their impact or consequences. There are different forms of crises, but they are generally classified into two types: industrial and natural [17]. Natural crises are caused by natural actions, while industrial (technological) crises include serious threats to human life, society and natural environment caused by industrial activities [18]. This is the oldest typology of crises, where industrial crises are caused by man and his actions, while natural crises are provoked by various natural phenomena [19]. Man-made crises are, for example: a plane or train accident, an incident at a factory plant, or a terrorist attack; while natural crises are tsunamis, avalanches, landslides, earthquakes, eruptions, typhoons, floods, etc. [20].

The causes of crisis outbreaks are numerous. Crises can be caused by various natural disasters, intentional human actions, unintentional human errors, errors in the functioning of the system. With the development of contemporary society, the causes of crises multiplied, so in the period before the industrial revolution, the main causes of crises, along with natural disasters, were international conflicts, while in modern civilization, beside natural disasters, errors in the functioning of the system become initial crisis events.

Organizational crisis is caused by various factors, which originate from internal or external organizational events, or are of a technical-economic nature, organizational-social nature, or represent an event caused by human action [21]. The different causes of each of these types of crisis are shown in Table I.

TABLE I. CAUSES OF ORGANIZATIONAL CRISIS [22]

	Internal	External
Technical/Economic	<ul style="list-style-type: none"> <li>Undetected, unanalysed or unsuspected product or service defect (in design, manufacturing, marketing, etc.)</li> </ul>	<ul style="list-style-type: none"> <li>Unanticipated and unanalysed environmental conditions (environmental issues that affect human life and society)</li> </ul>
	<ul style="list-style-type: none"> <li>Undetected plant defects (faults in machinery, etc.)</li> </ul>	<ul style="list-style-type: none"> <li>Faulty technical monitoring systems (monitoring malfunctions, disruptions etc.)</li> </ul>
	<ul style="list-style-type: none"> <li>Improper detection systems (faulty process monitoring techniques, etc.)</li> </ul>	<ul style="list-style-type: none"> <li>Improper strategic planning (of organizational goals and objectives)</li> </ul>
	<ul style="list-style-type: none"> <li>Faulty primary and backup design and control techniques</li> </ul>	<ul style="list-style-type: none"> <li>Improper social planning and global monitoring</li> </ul>
People/Social/Organizational	<ul style="list-style-type: none"> <li>Improper organizational control</li> </ul>	<ul style="list-style-type: none"> <li>Improper design and implementation of new social institutions</li> </ul>
	<ul style="list-style-type: none"> <li>Weak company culture (weak company values, improper communication, low motivation, etc.)</li> </ul>	<ul style="list-style-type: none"> <li>Improper social monitoring of criminal stakeholders (targeting and preventing incidents)</li> </ul>
	<ul style="list-style-type: none"> <li>Inadequate employee training</li> </ul>	
	<ul style="list-style-type: none"> <li>Improper contingency planning and crisis management</li> </ul>	
	<ul style="list-style-type: none"> <li>Human (unintentional) errors</li> </ul>	
	<ul style="list-style-type: none"> <li>Internal sabotages (with malicious intent)</li> </ul>	
<ul style="list-style-type: none"> <li>Improper employee screening (individual suitability)</li> </ul>		

Before a crisis occurs, there are early warning signs of a crisis, [23] sometimes very weak or hidden, and difficult to detect. Early warning signs of a crisis are not recognized in

time for several reasons, and they are usually [24]:

- weak or indistinguishable signals,
- sources of crisis signals are not considered credible,
- signals are built into routine messages,
- signals are systematically misrepresented,
- signals do not reach the adequate persons.

Timely recognition and better understanding of early crisis signs is of remarkable importance, in terms of timely detection of impending crises, so that regulators and other decision makers can plan effective measures to defend and overcome crisis impact.

### III. COVID-19 IMPACT ON SMEs

The crisis caused by COVID-19 pandemic has a strong impact on organizations, employees and the way they do business, which requires radical measures by government agencies to reduce business losses and ensure the survival of companies [25]. Working from home, almost completely canceling business trips, holding virtual meetings using various applications, high level of work engagement on digital platforms, have become part of everyday business life [26]. To manage the crisis, many companies have digitized their business processes, which at the same time has provided a safe work environment for their employees [26]. The COVID-19 crisis is characterized by a high level of inaccuracy and uncertainty, with the impossibility of organizational planning of preventive activities, which jeopardizes the survival and sustainable operation of companies, jeopardizes their goals, and requires rapid reactions [27].

Small and medium enterprises (SME) are endangered by the COVID-19 pandemic for several reasons, primarily due to limited resources and weaker market position [28]. The pandemic has altered the business conditions and has led to demand sensitivity, in relation to their products and services. The sectors most affected by restraint measures are those in which a large number of SMEs operate, and these are the sectors characterized by human contact and interaction, such as culture and the arts, fashion, tourism, and the airline industry [29].

A significant number of SMEs operated with business losses due to the COVID-19 restrictive measures. According to the results of 41 studies conducted in several countries around the world, which analyzed the pandemic effect on SME, more than half of the observed companies had worse business results, while one third predicted business closures within a month [30]. Research conducted in developing countries in Africa has shown that 4/5 of SMEs bore a considerable impact from the COVID-19 pandemic, in the form of a capacity

TABLE II. SME MEASURES IN RESPONSE TO COVID-19 PANDEMIC [33]

<b>Measures aimed at protecting the workforce</b>
<ul style="list-style-type: none"> <li>• A portfolio of protective policies and actions, including incident prevention</li> <li>• Multichannel communication; confidential reporting mechanisms</li> <li>• Separation (e.g. work from home); setting up business infrastructure (e.g. virtual private network VPN, computer, laptop); wide availability of infrastructure</li> <li>• Introduction of shift work; preventing the spread of infection (e.g. social distance); closing business locations</li> <li>• Cooperation with local and national regulatory bodies and public health officials</li> </ul>
<b>Measures aimed at stabilizing supply chains</b>
<ul style="list-style-type: none"> <li>• Risk transparency; re-engagement of suppliers; order management; checking the qualifications of new suppliers</li> <li>• Identification of critical activities; rationalization of activities; business location optimization</li> <li>• Assessing the impact of supply on business operations; optimization of production capacities</li> <li>• Inventory needs assessment; harmonization of production and procurement plans</li> <li>• Early reservation of logistics capacities; supply route optimization</li> </ul>
<b>Measures aimed at improving communication with customers</b>
<ul style="list-style-type: none"> <li>• Electronic communication between companies (B2B); Risk communications based on different scenarios</li> <li>• Interventions for preventing the spread of infection among customers; customers' training</li> <li>• Communication with customers about COVID-19 procedures; fact-based reports; situation communications</li> </ul>
<b>Measures aimed at defining financial needs</b>
<ul style="list-style-type: none"> <li>• Testing of relevant scenarios, based on the latest epidemiological and economic prospects</li> <li>• Assessment of financial needs, especially for working capital, in different scenarios</li> </ul>
<b>Measures aimed at centralizing crisis management activities</b>
<ul style="list-style-type: none"> <li>• Centralized problem solving; Including additional resources if needed</li> <li>• Portfolio of possible actions, depending on certain drivers (in all business activities)</li> <li>• Determination of leaders for different scenarios; Crisis situations simulations</li> </ul>

utilization decline, up to 30-40% [31].

A survey conducted on a sample of hundreds of companies around the world, provided insight into the main measures taken by SMEs, within the COVID-19 crisis strategies [32]. The most important of the applied measures are summarized in Table II.

SME support is an important part of the support package in many countries. Some of the measures apply to all business organizations, while others are specifically targeted at SMEs and their employees. According to [34], the most common support measures for SMEs during COVID-19 pandemic were credit financing and employment incentives. Examples of fiscal policy are given in various measures, in the form of tax reliefs, targeted at reduction of liquidity burden on SMEs and to help their businesses.

SME business support measures need to be reinforced in transition countries, especially impoverished economies. Support for sustainable business of SMEs should include measures to mitigate illiquidity; measures to support safety of employees; as well as to improve the efficiency of supply chains and the continuity of regular operations.

#### IV. THE IMPACTS OF KNOWLEDGE MANAGEMENT IN SMES

Training and informal education represents one of the most significant knowledge management mechanisms that can be used to mitigate the effects of various disturbances caused by COVID-19 pandemic. SME needs to assess its own body of knowledge and be aware of the lacks in information or procedure that can harm its business profit and endanger its position at the market. On the other side, any training and education activities represents certain cost for the SME, in terms that trainers should be paid, but also every absence of an employee from his workplace represents an expense. This is the reason why an entrepreneurial training and education in crisis business conditions, under the influence of the COVID-19 pandemic, should include precise knowledge and skills, in accordance with the new needs of SMEs, and in order to adapt to different market requirements [35]. Entrepreneurship education programs should also cover various crisis aspects of business and legal norms that are governing business in the

conditions of COVID-19 pandemic. It would be certainly useful to provide access to teaching materials in the form of e-learning on the internet platform, since this material can be used multiple times with adjustments when it is needed, employees can any time re-access to the material and there are potential savings since no face-to-face training is required [35].

An additional form of support for the empowerment of SMEs is the mentoring program, organized in Serbia by the Development Agency of Serbia (RAS) and the Japanese Agency for International Cooperation and Mentoring Development (JICA). The process of mentoring for SMEs includes the analysis of current operations, identification of the causes of existing obstacles for further development, and identification of key potentials for growth [36]. The areas in which mentoring can be carried out include: diagnosis of the current situation, assistance in the preparation and implementation of development activities, plans and projects, counseling and coordination in the process of accessing funds, new technologies, assistance in the preparation of loan applications, assistance in finding business partners, assistance in analytics and finding the necessary information, connecting with specialized consultants and other areas of importance in crisis business conditions [36].

Market reality and expected economic trends have been changed to a greater or lesser extent under the influence of COVID-19 crisis. The crisis also changed consumer habits, affected the market position of SMEs on the local market, but also on foreign trade, due to imposed restrictions or extended deadlines. Precisely in crisis conditions, one of the measures that can enable the survival and sustainable development of SMEs is mentoring. Mentoring can be adapted to different needs and realities: from defense strategy, to support in significant growth and development or a new investment cycle of SMEs. Mentoring implies an adequate level of expertise, and the application of the best business practices that can be adapted to the specific situation of each SME, and can be of great importance in the conditions of COVID-19 crisis [35].

Mentoring, compared to entrepreneurial training and education, has certain advantages in the form of individualization, tailored counseling regarding crisis business strategy,

business adaptation to extraordinary circumstances, interpretation and adaptation to new legal regulations, or similar situations, very specific for each SME. As in the case of entrepreneurial education, the mentoring process should be available on the internet platform, or different “remote” communication methods should be enabled, which would ensure the availability of SME mentoring advice during crisis circumstances, movement restrictions, illness and similar situations [35].

#### A. *The importance of innovation in the COVID-19 crisis conditions*

The crisis caused by COVID-19 pandemic once again confirmed that only companies that are flexible and capable of quickly adapting to new macroeconomic conditions can continue to grow and develop, and remain competitive on the market. The development and encouragement of innovation in SMEs is of great importance for the continuation of their successful business in accordance with the changed market conditions. This way, the sustainable business of SMEs and their further growth is achieved.

Innovativeness has a significant impact on the prosperity of the national economy and plays a major role in times of crisis. Innovative SMEs are considered drivers of economic growth, which especially includes companies in the high-tech sector. Reduced innovativeness in the years preceding the Global Financial Crisis, which broke out in 2008, contributed to the outbreak of the crisis and deepened its effects [37]. Innovativeness and recognition of opportunities in crisis conditions are important factors for the survival and sustainable business of SMEs [38]. Innovation is one of the most important factors for the recovery of SMEs even in the conditions of COVID-19 crisis, as well as an incentive for the recovery and development of the entire national economy [39]. SME innovativeness leads to long-term benefits for SMEs and can significantly help mitigate the impact of COVID-19 pandemic. It represents a solution for the growth and development of these companies in crisis conditions.

In particular, the open innovation process is of great importance for SMEs in periods of crisis. If the open exchange of knowledge between companies is encouraged in the national economy, then SMEs can gain new knowledge that will enable them to improve

their innovative processes. Knowledge sharing includes their suppliers, customers and other external sources of knowledge. The innovative process is improved through cooperation with complementary companies during which knowledge is exchanged and creativity is encouraged [40].

However, innovative activities imply the availability of financial resources, and at the same time carry with them risk and uncertainty. SMEs face difficult access to financial resources, which threatens innovative processes in these companies and makes it difficult for them to survive and operate profitably in the conditions of COVID-19 crisis [39]. SMEs that have available funds to enable investment in innovation, and maintain a certain degree of innovativeness, will have more significant chances for survival, growth and profitability in crisis conditions [41].

## V. CONCLUSIONS

Crisis circumstances are defined by a large number of unpredictable risks, which are interdependent, and have a strong impact on the profitable business and corporate sustainability. Crisis management in SMEs requires creative business solutions, which are not needed during regular operations.

Crisis management in SMEs requires planning of sustainability and business continuity, preparation for potential crisis situations, as well as providing the necessary resources to deal with unpredictable circumstances. It is necessary to adjust the organizational culture, structure and business processes, in order to respond in a timely manner to anticipated or sudden changes in the environment. These adjustments ensure profitable and sustainable business operations, and should be part of the strategic management process in SMEs.

Regardless of the threats faced by SMEs, the COVID-19 pandemic has also created new opportunities for profitable business. New needs have emerged in the market for some indispensable products and services, including personal protective and preventive tools, and other medical goods and resources. Pandemic-accelerated digitization has led to demand for digital products and services, although the digitization process is uneven across national economies. In developed and upper-middle economies, the digitalization process is more

intensive, although in these countries there is already a developed digital infrastructure, online commerce and distribution network.

Crisis management is a challenge for SMEs, where managers need to make strategic decisions in the most difficult circumstances, in order to reduce the harmful crisis effects on business and take advantage of new opportunities. Crisis management is the mechanism of identifying and anticipating a potential crisis, and acting to mitigate its negative effects on business. This process shouldn't be a defensive reaction to the crisis effects, but also as a foresighted way of management, which includes preventive action, preparedness and recovery of the company. Knowledge management should be support of crisis management in SMEs. Entrepreneurship education programs should cover various crisis aspects of business and legal norms of governing business in crisis conditions. Educational material should be in the form of e-learning, provided on the internet platform.

#### ACKNOWLEDGMENT

This paper is the result of research within the project: eDLP4MSMe - Distance Learning Platform for the MSMEs and Entrepreneurs (2021-1-RS01-KA210-ADU-000027368) financed by the EU.

#### REFERENCES

- [1] Al-Ajlouni, M. M. (2009). Crisis management in the banking sector in the northern region. *Journal of Baghdad College of Economic Sciences*, 20-b(20), 191–218.
- [2] Shaluf, I. M., & Said, A. M. (2003). A review of disaster and crisis. *Disaster Prevention and Management: An International Journal*, 12(1), 24–32.
- [3] Missiroli, A. (2006). Disasters past and present: Challenges for the EU. *Journal of European Integration*, 28(5), 423–436.
- [4] Posner, R. (2004). *Catastrophe: Risk and response*. Oxford University Press.
- [5] Robb, J. (2007). *Brave new war: The next stage of terrorism and the end of globalization*. John Wiley & Sons.
- [6] Rosenthal, U., Boin, R. A., & Comfort, L. K. (2001). *Managing crisis: Threats, dilemmas, opportunities*. Charles T Thomas Pub Ltd.
- [7] Strauß, N., & Jonkman, J. (2017). The benefit of issue management: Anticipating crises in the digital age. *Journal of Communication Management*, 21(1), 34–50.
- [8] Boin, A., & Hart, P. T. (2003). Public leadership in times of crisis: mission impossible? *Public Administration Review*, 63(5), 544-553.
- [9] Perry, R. W. (2006). What is a disaster? In Rodrigues, H., Quarantelli, E., Dynes, R. (Eds.). *Handbook of disaster research* (pp. 1-15). Springer.
- [10] Deverell, E. C. (2010). *Crisis induced learning in public sector organizations*. Elanders Sverige.
- [11] Mishra, A. (1996). Organizational responses to crisis: The centrality of trust. In: Kramer, R. M., & Tyler, T. (Eds.), *Trust in organizations* (pp. 261-287). Sage.
- [12] Weick, K. E. (1988). Enacted sensemaking in crisis situations. *Journal of Management Studies*, 25(4), 305-317.
- [13] Hermann, C. F. (1963). Some consequences of crisis which limit the viability of organizations. *Administrative Science Quarterly*, 8(1), 61-82.
- [14] McConnell, A., & Drennan, L. (2006). Mission impossible? Planning and preparing for crisis. *Journal of Contingencies and Crisis Management*, 14(2), 59-70.
- [15] Brockner, J., & James, E. H. (2008). Toward an understanding of when executives see crisis as opportunity. *Journal of Applied Behavioral Science*, 44(1), 94-115.
- [16] Veil, S. R. (2011). Mindful learning in crisis management. *Journal of Business Communication*, 48(2), 116-147.
- [17] Cretu, P. M., & Alvarez, J. (2011). *Managing Organizational Crises in the Light of Political Unrest: The „Gulf Agency Company“ Egypt Case*. Master of Science in Business Administration, Linköping University.
- [18] Smith, D., & Elliot, D. (2006). *Key Readings in Crisis Management: Systems and Structures for Prevention and Recovery (1st ed.)*. Routledge Publishers.
- [19] Rosenthal, U., & Kouzmin, A. (1997). Crises and Crisis management: Toward Comprehensive Government Decision Making. *Journal of public administration research and theory*, 7(2), 277-304.
- [20] Nogueira, J. H. M. (2016). *A crisis management framework for INTERPOL to manage transnational disasters*. Doctoral Thesis, University of Liverpool.
- [21] Farantos, G. I., & Koutsoukis, N. S. (2015). *Integrated Crisis Management: A literature review*, International Exchanges on Communication, Management and Marketing, Communication Institute of Greece, Athens (pp. 35-53).
- [22] Marinovic Matovic, I., & Lazarevic, A. (2022). Adapted according to Mitroff, I.I., Shrivastava, P., Udwardia, F.E. (1987). Effective crisis management. *Academy of Management*, 1(4), 283-292.
- [23] Mitroff, I. I., & Anagnos, G. (2001). Managing Crisis before They Happen: What Every Executive and Manager Needs to Know about Crisis Management. American Management Association.
- [24] Seeger, M. W., Sellnow, T. L., & Ulmer, R. R. (2003). *Communication and Organizational Crisis*. Preager Publishers.
- [25] Shafi, M., Liu, J., & Ren, W. (2020). Impact of COVID-19 pandemic on micro, small, and medium-sized Enterprises operating in Pakistan. *Research in Globalization*, 2(December), 100018, 1-14.
- [26] Atilgan, O. (2020). Chapter 8: COVID-19 and crisis management, In *COVID-19 and New Business Ecosystem*. Gazi Kitabevi.

- [27] Gostin, L. O., & Wiley, L. F. (2020). Governmental public health powers during the COVID-19 pandemic: stay-at-home orders, business closures, and travel restrictions. *Jama*, 323(21), 2137-2138.
- [28] Alves, J. C., Lok, T. Ch., Luo, Y. B., & Hao, W. (2020). *Crisis Management for Small Business during the COVID-19 Outbreak: Survival, Resilience and Renewal Strategies of Firms in Macau*. Research Square.
- [29] ITRE European Parliament's committee on Industry, Research and Energy. (2021). *Impacts of the COVID-19 pandemic on EU industries*. Available at: [https://www.europarl.europa.eu/RegData/etudes/STUD/2021/662903/IPOL\\_STU\(2021\)662903\\_EN.pdf](https://www.europarl.europa.eu/RegData/etudes/STUD/2021/662903/IPOL_STU(2021)662903_EN.pdf).
- [30] OECD. (2020). *COVID-19: SME policy responses*. Available at: <https://www.oecd.org/coronavirus/policy-responses/coronavirus-COVID-19-sme-policy-responses-04440101/>.
- [31] Economic Commission for Africa and International Economics Consulting. (2020). *Insights on African businesses' reactions and outlook to COVID-19*. Available at: <https://www.uneca.org/publications/insightsafrican-businesses%E2%80%99-reactions-and-outlook-COVID-19>.
- [32] McKinsey Company. (2020). *COVID-19: Implications for Business*, Briefing note #3, March 16, 2020. Available at: <https://www.mckinsey.com/business-functions/risk/our-insights/COVID-19-implications-for-business>.
- [33] Marinovic Matovic, I., & Lazarevic, A. (2022). Adapted according to McKinsey Company. (2020). *COVID-19: Implications for Business*, Briefing note #3, March 16, 2020. Available at: <https://www.mckinsey.com/business-functions/risk/our-insights/COVID-19-implications-for-business>.
- [34] World Bank. (2020). *Map of SME support measures in response to COVID-19*. Available at: <https://www.worldbank.org/en/data/interactive/2020/04/14/map-of-sme-support-measures-in-response-to-COVID-19>.
- [35] Marinovic Matovic, I. (2022). Determinante održivosti poslovanja i profitabilnosti malih i srednjih preduzeća u Republici Srbiji u uslovima COVID-19, Doctoral dissertation, University of Pristina Faculty of Economics.
- [36] RAS Razvojna agencija Srbije. (2020). *Saradnja sa japanskom agencijom za medjunarodnu saradnju i razvoj mentoringa*, Available at: <https://ras.gov.rs/aktuelno/projekti/japanska-agencija-za-medunarodnu-saradnju-jica>
- [37] Hausman, A., & Johnston, W. J. (2014). The role of innovation in driving the economy: Lessons from the global financial crisis. *Journal of Business Research*, 67(1), 2720–2726.
- [38] Devece, C., Peris-Ortiz, M., & Rueda-Armengot, C. (2016). Entrepreneurship during economic crisis: Success factors and paths to failure. *Journal of Business Research*, 69(11), 5366–5370.
- [39] Paunović, B., & Aničić, Z. (2021). Impact of the COVID-19 crisis on SMEs and possible innovation responses. *Ekonomika preduzeća*, 69(3-4), 169-184.
- [40] Gassmann, O., & Enkel, E. (2004). Towards a theory of open innovation: Three core process archetypes. Proceedings of the R&D Management Conference (RADMA), Lisbon. Retrieved from Available at: [https://www.alexandria.unisg.ch/274/1/Gassmann\\_Enkel.pdf](https://www.alexandria.unisg.ch/274/1/Gassmann_Enkel.pdf).
- [41] Roper, S., & Turner, J. (2020). R&D and innovation after COVID19: What can we expect? A review of prior research and data trends after the great financial crisis. *International Small Business Journal*, 38(6), 504–514



# The Significance of Sustainability and the Management of the Green Economy using Modern Technology

Biljana Ilić<sup>1</sup>, Zorica Djurić<sup>2</sup>

<sup>1</sup>Faculty of Management Zaječar, Zaječar, Serbia

<sup>2</sup>Alfa BK University Belgrade, Belgrade, Serbia

<sup>1</sup>biljana.ilic@fmz.edu.rs, <sup>2</sup>zorica.djuric@alfa.edu.rs

**Abstract**—Global acknowledgment of the necessity of the shift to a green economy has been sparked by research into the negative impacts of past behavioral patterns and business models on the environment and human health. A green economy must be built on aims that are vastly different from the current, unsustainable ones. Understanding the interdependence between human and ecological well-being is the key because it inspires efforts to promote a fair and environmentally responsible economic system. The emphasis is shifted to long-term sustainable economic development with environmental protection as a result of the new opportunities for sensible decision-making at all levels, including those of the state, the economy, and the individual. By balancing contemporary accomplishments and business with the objectives of the green economy, the paper will modestly contribute to highlighting the value of new technology in specific spheres of human life.

**Keywords** – green economy, business models, environment, new technologies, management.

## I. INTRODUCTION

This The global economic growth paradigm in use today is, for the most part, unsustainable. Natural resource depletion, environmental degradation, the acceleration of climate change, and social stratification result from this. If sustainable policies are followed, the government sector is globally accountable for both the abolition of unproductive state policies in the area of the green economy as well as the creation of effective and sustainable policies, such as the adoption of green public procurement. The promotion of the shift to

circular business models should be the fundamental responsibility of every nation's economic sector. This would include changing company structures that focus primarily on making a profit and fostering economic growth. It would be required to curtail people's careless hyperconsumption at the consumer level, or the individual level.

By promoting economic growth while lowering resource consumption, the shift to a green economy moves society closer to intelligent, inclusive, and sustainable development. It is vital to bring logistics simplification, lessen reliance on suppliers, increase product control, and eventually stop future ecosystem harm. The green economy comprises ethical business practices like ecological agriculture, the advancement of green technology, recycling, and waste management, the digitization of services, water management, and environmentally friendly architecture, building, and design. The green economy is connected to green social innovations, green scientific-technological advancements, and circular economies. The circular economy prioritizes, among other things, waste recycling, waste reuse as raw material, waste prevention, waste reduction costs, and company improvement. In this way, numerous initiatives/processes have been started to create a green and circular economy. However, aside from trash management, no notable outcomes were made due to the fragmented approach, lack of preventative measures, and financial assistance from local and national agencies. The green and circular economies offer enormous





Figure 1. Figuratively – Green economy to greater results

opportunities for small and medium-sized businesses, the procurement sector, and an opportunity to improve energy efficiency, but there is very little knowledge of their advantages. The conclusion is that a more methodical, thorough, and long-term approach is required. At that point, creative approaches and the adoption of fresh technologies into business are put to use.

In the period of the economic crisis of 2008, the green economy asserts anew and tries to offer answers to the increasingly numerous challenges of the global financial crisis and the entire concept of sustainable development. The United Nations Environment Program (UNEP) is launching the Green Economy Initiative to create a framework and gain political support for investments in the green economy and the “greening” of environmentally harmful sectors of the economy. In 2009, a report called the Global Green New Deal<sup>4</sup> (GGND) proposed a series of measures and policies that would contribute to economic recovery and at the same time encourage a higher level of environmental responsibility, sustainable economy and respect for the principles of sustainable development. This program intensively called on the member governments of the UN, and primarily the governments of the most developed countries of the world (G20), to make greater efforts and redirect at least 1% of the gross domestic product (GDP) to start the green economy sector. In this way, it contributes to the simultaneous achievement of mutually complementary goals: economic recovery, reduction of poverty and reduction of CO<sub>2</sub> emissions and ecosystem degradation. The big and important goals of the recovery of the world economy, the creation of new, better quality and cleaner jobs and finding a model of more responsible management of human resources are

put before the green economy. In the following years, the concept of green economy becomes generally accepted through numerous initiatives, international conferences and the inclusion of new groups of actors (entrepreneurs, socially responsible corporations, international development institutions, financial institutions, academic institutions, non-governmental organizations, incubators, employment agencies, etc.).

New publications are being created that more closely define the key principles, benefits and risks and highlight good practice examples of green economy and green entrepreneurship. The UN conference on sustainable development RIO+20, held in 2012, devoted full attention to the further improvement of the green economy with greater emphasis on ways of supporting developing countries in finding their own green economy model. This comprehensive concept of development, which simultaneously encourages poverty reduction, development of rural areas, while taking care of food security, providing access to clean water and energy as well as a whole range of issues of environmental protection and biodiversity, is not easily implemented due to its complexity. Therefore, every country should have a long-term green economy development plan with clearly defined priority areas. The challenges for poor and developing countries are even greater because, due to a lack of resources (knowledge, technology, financial resources and public support), they cannot simultaneously initiate all areas of development. The green economy encourages development, it is inclusive - it encourages social equality and cares for the preservation of the environment [1].

Therefore, the green economy significantly reduces the introduction of crisis management in organizations that respect the principles of sustainable business. Also, the green economy encourages the development of new technologies and innovations, so that the operations of modern organizations meet the requirements of sustainability.

## II. EXAMPLES OF GREEN AND CIRCULAR ECONOMY

The Smart Collective is a pioneer in Serbia when it comes to promoting socially responsible companies because they believe that businesses should and can play a beneficial role in social development. The goal to create corporate social responsibility (CSR) as a common company

practice through education, empowerment, networking, increasing awareness, and launching numerous events and projects is what drives Smart Collective's involvement in the growth and advancement of CSR in Serbia [2]. Serbia is an example of a country in the region that is rich in natural resources and dependent on economic activities that contribute to their destruction and the reduction of the capacity and quality of the ecosystem, as stated in the study of the Smart collective, supported by the European Union, on the topic of a green future. The reliance on the dirtiest fossil fuels for the whole economic expansion of the GDP is a result of the dependency on coal as the primary resource in the production of electricity. In addition, this method of energy production results in 70% of all trash being produced. Clear standards, incentive rules, and quality-directed investments were highlighted as essential preconditions for the development of the green economy.

Numerous useful concepts and tools for enhancing company operations are made possible by green and circular economies. Many businesses (H&M, Lenovo, Feydom Furniture, Sony Group Corporation, Audible, etc.) were urged to implement procedures for product recycling and reuse as well as product digitalization, which gave them a higher position in the market among conscientious consumers. So, for instance, the aforementioned brand H&M created a take-back program that allows customers to return used clothing in exchange for a voucher that can be applied to their subsequent purchases at H&M. The method described allows for the reduction of waste clothing and textiles that would otherwise end up in landfills, the facilitation of material circulation (through recycling or sale on the second-hand market), and the stimulation of consumer thought toward more sustainable practices and consumption patterns. The company Feydom Furniture doo, Skopje, is one of the examples relating to the furniture industry in the area. Its design, which is a fundamental component of the concept, enables product modularity, and application in multiple ways, and encourages customers to take an innovative approach to product use. Here are some instances from the world of IT. Lenovo has set up a device-as-a-service (DaaS) service that lets customers rent items. The business offers device management, configuration, servicing, support, and other IT solutions in a customizable manner.

Extended producer responsibility (EPR) through product life cycle management after use and increased business efficiency and effectiveness are the main outcomes of the aforementioned. PS Plus is a paid PlayStation subscription service offered by Sony Group Corporation. Members have access to online multiplayer gaming, special discounts from the PlayStation Store, 100GB of game cloud storage, and bonus content in addition to being able to download two PS4 downloadable games each month. As a result, the CDs were converted to digital format, and the aforementioned advantages inspired players to improve their practice while preserving their gaming experience. Audible has reinvented the media category and is the primary driver behind the current audio entertainment revolution thanks to access to cutting-edge technological innovation and superior user-centric programming. Every day, Audible enriches the lives of millions of listeners by offering audiobook content, Audible originals, and exclusive podcasts [3]. Audible is a market leader in the creation and distribution of quality audio storytelling.

### III. TECHNOLOGICAL INNOVATION – MODERN TECHNOLOGY

Information technologies are a recent development in technology that has impacted every part of modern life. It is now impossible to imagine how the information would flow without the use of information technologies. Informatics is one of the most recent and difficult topics in today's world. The French Academy of Sciences defines informatics as the discipline of rational information processing, primarily employing automatic machines, as information is recognized as the bearer of human knowledge and communications in the fields of technology, economics, and other social sciences [4]. As opposed to only being related to electronic data organization systems (ELSOP), French scientist Arzac (Arsac J.) said that this developing field is far larger and involves several topics [5]. The weightless economy, or electronic commerce, depends on information technologies, which are frequently referred to as new technologies in today's society. Electronic business plays a significant role in organizational changes and opens the door for new business models, requiring a review of the guiding principles for its implementation and raising doubts about the effectiveness of conventional business practices and policies, the majority of which were created based on

outdated theories in comparison to contemporary realities. Electronic business is a way of business that relies on technology and the Internet. It includes all business transactions and information exchanges enabled by information and communication technology, such as those that take place between corporations, between corporations and consumers, and between corporations and the government [6]. “The purchasing and selling of information, goods, and services over a computer network and support for any type of economic transaction using a digital infrastructure” are the definitions of electronic business. No of the constraints of time or space, it is all about business [7]. “The more advanced the tools employed in business, the more likely it is that a market will be close to being realized by the laws governing it. However, because the hazards of economic misconduct of all kinds are increasing, there is also a need for better social and governmental scrutiny as well as commercial legal regulation” [8]. E-commerce stands out as a distinct category within the context of global economic trends because of its exceptional penetration and distribution, paving the way for the “internet economy,” a brand-new economic structure. Electronic data exchange, business records built on EDI (an acronym for the English word “Electronic Data Interchange”), and the Internet allowed multinational firms to connect with their affiliates, business partners, and subcontractors throughout the country and around the world. The “network economy” strategy is the foundation of the new sustainable economy. Customers can save money, time, and space thanks to it. Network economies, digital economies, and knowledge economies are all examples of “post-industrial societies.” The idea of the “new economy” initially surfaced, in theory, a few years ago [9]. In this new scientific paradigm that must account for all of the economic, social, and cultural changes brought about by ICT (Information Communication Technologies), the Internet holds the position of “honor” [10]. In the Internet economy, payment methods and transactions are essential to business relationships and operations (as well as in traditional conceptions of economics). There is a very strong and substantial relationship between new technologies and the management of the green economy. This is also demonstrated in the cases in this paper, particularly those that concern the businesses Lenovo, Sony Group, and Audible. Information technologies, however, take things a step further by integrating

cloud technology into numerous commercial sectors. Utilizing the cloud as a novel method of data processing and archival is one of the most recent advancements in information technology. Cloud accounting, sometimes referred to as online accounting, web accounting, or virtual accounting systems, is currently receiving more and more attention. One of the most important approaches to ensure the efficiency of the accounting information system is to adopt these technology solutions [11]. In this way, paper, a fundamental tool for work in old, classical accounting, is conserved along with time. The environment is preserved since numbers are now practically memorized rather than being written down on paper. Of course, the whole process of protecting the environment and fostering a sustainable economy can be broken down in the sense that if less paper is used in jobs that require writing and calculation (like accounting services), then the wood will not be used as the primary raw material for paper production. As a result, forests are protected, but there is no technology involved in turning the wood into paper. Therefore, if virtual data processing technology is employed, the expenses of procuring materials for work organization are decreased because there is less need for paper. The business runs sustainably and gets paid extra for being socially conscious. By doing this, the organization's goods will be easier to recognize and more competitive in the market. On the other hand, because it will be used less, wood processing technology won't hurt the environment. so forth. It is a circular or green economy as a result.

#### IV. CLOUD COMPUTING AND VIRTUAL REALITY - GENERAL DETERMINANTS

The processing capacity of the computer used in the cloud environment is currently the issue, not the access technology, which is at a reasonable level. It is common knowledge that software capabilities currently far outpace what our hardware is capable of. Quantum computing consequently started to advance. With its appearance, cloud computing technology has led to a revolution in numerous spheres, among others in the field of business software, i.e. business information systems. A version of this technology called Software as a Service (SaaS) has provided the opportunity for numerous companies to outsource part of their business processes to independent providers, specialized in various types of business information systems, i.e. business functions of the

company [12]. Artificial intelligence is a subfield of study that involves the artificial reproduction of the cognitive abilities of human intelligence to produce software or machines capable of performing functions that are usually inherent only to humans [13]. There are several instances of artificial intelligence being used in business. Since 2015, Google has used its Rank Brain artificial intelligence platform for marketing via chatbots, data analysis, product recommendations, and dynamic pricing. Robotics and rule-based systems are frequently used in conjunction with artificial intelligence to forecast outcomes and drive autonomous procedures. Artificial intelligence is ultimately something that internet entrepreneurs will unintentionally employ as a key component of a product or application, similar to huge data, and the results of this reality are significantly more significant than the technology that helps achieve it [14]. Machines that have artificial intelligence built into them can recognize faces, speak, and even win chess games without human intervention. They can also learn from experience and adapt to new inputs. Despite being around since the 1950s, artificial intelligence is currently being used more frequently than ever thanks to the growth in IoT data volume, high-speed connectivity, and high-performance computation. Nowadays, artificial intelligence employs a variety of computational and statistical methods.

Virtual reality is increasingly being used for business endeavors, and educational institutions are starting to adopt it. Virtual reality, a field of technology, promises to revolutionize the way we view and interact with information, our social networks, and the rest of the world. Virtual reality, in general, is a computer-generated simulation of a 3D environment that, to the participant, appears to be reality. Virtual reality aims to persuade the user that it is just as real as the outside world. With today's VR technology, virtually everyone may enjoy this technology. Simply turning the head in the appropriate direction and using control sticks or motion sensors to walk, anybody can explore. To make the experience as genuine to the user as possible, virtual reality makes an effort to engage all of the senses of the user.

It appears as though the user is in the virtual world, which is an entirely different place and time. Since all of the fundamental research has already been completed, a considerably bigger population than before can now access this

technology. There is a large developer community with expertise in creating 3D mobile app games. All online activities and user experiences, including engineering, socializing, purchasing, marketing, entertainment, and business growth, can be enhanced by the level of focus and presence that VR provides. Perhaps soon, using VR to access 3D websites will become as commonplace as using a screen to access 2D websites is right now. The following sorts of applications are currently being created in the context of virtual reality, according to Rankovic et al., and are utilized by various kinds of businesses. [15] Tourism and travel With the aid of virtual reality glasses, this kind of application enables users to visit locations on the other side of the world, museums in cities miles away, attend festivals, and the like from their homes within a short amount of time. Software for mechanical engineering and industrial design, including AutoCAD and SOLIDWORKS, aids in modeling, simulating, and visualizing original solutions. Engineers and designers can see the finished product in virtual reality before it is produced. Additionally, since the expenses are relatively modest at that point in the process of developing a solution, this allows for some experimentation and freedom [16]. Construction and Architecture - To be able to present the concept to customers, and investors, or, more significantly, to be able to test their design assumptions, architects and engineers have continuously created mock-ups of their design solutions. Software is currently used to create virtual models of architectural plans for modeling and rendering. Virtual reality enables talks with stakeholders to be conducted with a great deal more assurance and confidence in the model itself. In addition to everything mentioned above, having such a model would make it possible to incorporate additional project partners, such as interior designers, electrical engineers, and others, far earlier [15]. To draw in as many customers as possible, real estate companies were among the first to use the Internet and various visualization technologies. They generated as many sales as they could. It has become standard practice for agencies to provide an online panoramic video of the entire property being sold. The buyer may fully experience a house that may be thousands of kilometers away from him thanks to virtual reality [15] Medical: When discussing the use of virtual reality in medicine, instances are given that show just how far this technology may be essential. Every day, hospitals make models of

bones and organs using MRI and other scanners. These models will then be utilized for diagnosis or potential pre-operative plans. The analysis itself is improved by utilizing virtual reality to produce more sophisticated visualization and measurements. VR is employed in training for students who intend to practice surgery in addition to this application [17]. Mental health Patients with post-traumatic stress disorder have been demonstrated to benefit from and benefit from therapy when using virtual reality (PTSD). Similar to the example given above, VR has been shown to help people overcome their fears of flying and arachnophobia (the fear of spiders). Education: Everyone can immediately see how educationally beneficial virtual reality is. Virtual reality can be considerably more profitable and economical in the long term, in addition to being a better method of teaching. To educate youngsters about the risks and repercussions associated with driving while distracted, Toyota developed a simulation for drivers using virtual reality as an example. Students had the chance to operate cranes and other construction-related machinery as part of another project. Police officers and firefighters could benefit from a similar type of training that would enhance their performance in emergencies. Along with these instances, the American National Football League NFL and numerous colleges are seeking VR training to benefit their athletes [17]. Entertainment: virtually attending rock concerts and other events, as well as sporting events. Better news experience, (from the scene), as if you were in the field with the reporter. additional 360-degree video content [18]. One of the best examples of virtual reality being used in electronic commerce is the well-known website eBay, which in 2016 established the first virtual department store in collaboration with the Australian corporation Mayer. The merchandise at this department store can be viewed by customers with the use of a mobile smartphone and a VR case. Users have the power to move, rotate, and magnify the products themselves, as well as view real-time availability information and, most importantly, make a purchase [19,20].

## V. CONCLUSION

A new crucial skill has emerged as a result of the development of the Internet: online research. This ability is the outcome of technological advancements that have made it necessary to prepare people for life in the digital era. Today, pertinent information may be quickly discovered online. Due to this reality,

everyone occasionally struggles with a lack of abilities. These abilities, which people require in a variety of circumstances, can be learned and developed via experience. Many platforms exist for people to learn new skills and to enhance the ones they already possess, but before upgrading, sometimes people require assistance identifying knowledge gaps. In all spheres of human life, the world today is undergoing significant and quick changes. The preservation of a healthy ecosystem and the natural world, however, is essential. Getting the most output out of the fewest resources invested is one of the objectives of the economy. The green economy is an improvement above the traditional economy. It is an economy that balances corporate opportunities and regulatory frameworks with those of the natural world. If you don't consider the cost associated with such a result, we can't talk about good business results. These objectives and outcomes are specifically addressed by the green economy on a global scale. Since new technologies are a crucial component of modern living, they must be used to advance the green economy.

## REFERENCES

- [1] Vukovic, S., Coric, G., Lisjak, D. (2020). *Green economy for regional development* (Serbian: Zelena ekonomija za razvoj regiona). FORS:Montenegro.
- [2] Smart Collective (2022). *Smart Collective*. Available at: <https://smartkolektiv.org/>
- [3] The green economy towards sustainable development (Serbian: Zelenom ekonomijom ka održivom razvoju). Available at: <https://www.juznevesti.com/Ekonomija/Zelenom-ekonomijom-ka-odrzivom-razvoju.sr.html>
- [4] Bozic, N., Aleksic, D. (2016). *Green economy - challenges and opportunities* (Serbian: Zelena ekonomija-izazovi i mogućnosti). Union of Ecologists UNEKO, Sabac, Serbia.
- [5] Choi, S.J., Whinston., A. (2002). *Economics of Electronic commerce*. Dahle Stahl.
- [6] Frank J. Derfler Jr. Les Freed (2004). *How networks work (7th edition)*. Jenson Books Inc.
- [7] Ilic, B. (2019). Sustainable Business In Modern Technologies - Contribution To Modern Economy. In *Proceeding of 11. International conference Digital transformation of the economy and society: shaping the future* (pp. 241-250).
- [8] Jovanović, R. (1998). *Information system development* (Serbian: Razvoj informacionog sistema). Faculty of Economics, Nis, Serbia.
- [9] Milovanovic, G., Veselinovic, P. (2009). *Globalization and transition*. Faculty of Economics, Kragujevac, Serbia
- [10] Mladenovic, I., Jovanovic, R., (2007). *Electronic Business*. Faculty of Technology, Leskovac, University of Economics, Nis, Serbia.

- [11] Djordjevic, M., Radovic, O. & Bonic, L. (2018). Potentials for applying cloud technology in accounting. *Ekonomika, Journal for Economic Theory and Practice and Social Issues*, 64(1350-2019-2844), 23-32.
- [12] Simović, V. (2020). The Factors Affecting the level of Digital Entrepreneurial Competences of University Students. *Economic Analysis*, 53(2), 145-155.
- [13] Ministère de l'Éducation et de l'Enseignement supérieur. (2019). Digital Competency Framework. Québec: Gouvernement du Québec. Available at: [http://www.education.gouv.qc.ca/fileadmin/site\\_web/documents/ministere/Cadre-reference-competence-num-AN.pdf](http://www.education.gouv.qc.ca/fileadmin/site_web/documents/ministere/Cadre-reference-competence-num-AN.pdf)
- [14] Charlesworth, A. (2020). *Absolute Essentials of Digital Marketing*. London: Routledge.
- [15] Ranković, M., Dedić, V., Jovanović, M., Petrović, D. & Ilić, M. (2020). Escape rooms in virtual reality, the concept and application in electronic business doing. *Independent Journal of Management & Production*, 11(4), 1247-1261.
- [16] Simović, V. & Domazet, I. (2021). An overview of the frameworks for measuring the digital competencies of the students: a European perspective. In U.T. Neimann, J. J. Felix, S. Reeves, & E. Shliakhovchuk, *Stagnancy Issues and Change Initiatives for Global Education in the Digital Age*.
- [17] Linowes, J. (2018). *Unity Virtual Reality Projects Second Edition*. Birmingham: Packt Publishing.
- [18] López-Meneses, E., Sirignano, F., Vázquez-Cano, E., & Ramírez-Hurtado, J. (2020). University students' digital competence in three areas of the DigCom 2.1 model: A comparative study at three European universities. *Australasian Journal of Educational Technology*, 1(5), 69- 88.
- [19] Tom Dieck, C., & Jung, T. (2019). *Augmented Reality and Virtual Reality, The Power of AR and VR for Business*. Springer Nature Switzerland AG.
- [20] Djukic, G. P., Biljana, I. S., & Milovanović, G. R. (2022). Eco-Innovation and IT Technologies for Sustainable Development of Health and Recreational Tourism of Serbia. In U. Akkucuk (Ed.), *Disruptive Technologies and Eco-Innovation for Sustainable Development* (pp. 171-190). IGI Global.



# The Importance of Innovation and Creativity of Employees in Modern Organizations

Dragana Kovač<sup>1</sup>, Edit Terek Stojanović<sup>2</sup>, Mihalj Bakator<sup>3</sup>, Mila Kavalić<sup>4</sup>, Verica Gluvakov<sup>5</sup>, Maja Gaborov<sup>6</sup>

<sup>1,2,3,4,5,6</sup>University of Novi Sad, Technical Faculty “Mihajlo Pupin”, Zrenjanin, Serbia

<sup>1</sup>milosavljevd@yahoo.com, <sup>2</sup>terekedita@gmail.com, <sup>3</sup>mihaljbakator@gmail.com,  
<sup>4</sup>milazakin@gmail.com, <sup>5</sup>vekagluvakov@gmail.com, <sup>6</sup>majagaborov26@gmail.com

**Abstract** – Modern business is characterized by constant changes. These changes are mostly related to changes in technology, organizational structure, management models, consumer demands, etc. Consumer demands have influenced the fact that now, in addition to high-quality products and services, they also need to be unique and different. Precisely because of this, employees are required to possess a wide range of knowledge and skills, which they constantly improve, but also to be creative and innovative, in order to be able to respond to these demands. This paper will present the characteristics of modern organizations, that is, modern business, explain the concepts of creativity and innovation, and explain the impact these employee skills have on the success of modern organizations.

**Keywords** – modern business, innovation, creativity, knowledge

## I. INTRODUCTION

One of the basic prerequisites for business success, in today's turbulent business, is the ability for organizations to quickly respond to the changes that affect them. The globalization of business, the development of high technology, changes in the wishes and demands of consumers, are just some of the characteristics that change the modern environment, which significantly influence the change in business activities [1]. The dominant factor influencing the success of business is the knowledge that employees have [2]. These days knowledge should not be reduced to only general, that is, formal knowledge, acquired through education.

Business success demands constant learning, improvement and acquisition of new knowledge and skills. This implies informal education, which is reflected in the improvement and development of business competencies [3]. All these changes have led to changes in the wishes of consumers. Apart from products and services that must be of extremely high quality, they now demand something that is unique, interesting, and innovative. Therefore, employees are required to be innovative and creative. Creativity represents the ability to create new ideas and new ways of solving problems, and innovation means turning those creative ideas into action. Creativity and innovation are key skills for employees and one of the best ways for an organization to be far ahead of competitors [4]. Therefore, the success of a company in turbulent business conditions requires a quick response to changes. In order for this to be possible, it is necessary to create a creative working environment, in which employees will cultivate their creative potential, be more innovative, productive, more satisfied with their work and where the probability of turnover will be reduced to a minimum [5].

## II. CHARACTERISTICS OF MODERN ORGANIZATIONS

The only thing certain in modern business is change. Modern organizations operate in a turbulent environment, they are influenced by numerous internal and external factors, which determine their business behavior and affect business results [6]. To achieve business success,



organizations must be prepared to responses to all changes. These changes refer to changes in technology, production, use of modern business models, employee abilities, etc. Responses to these changes should be based on the application of management techniques, which will entail the constant improvement of employees' knowledge, their creativity, innovation, and flexibility [7, 8]. Therefore, modern business is based on the economy of knowledge. The performance of an organization represents the aggregate performance of all the activities it undertakes. Knowledge and knowledge management therefore represent an integral part of the continuous improvement of organizational performance, as it ensures that the organization identifies, examines and exploits market opportunities, which ultimately ensures superior performance [9].

Technological changes also have a major impact on the success of organizations. Namely, organizations must keep up with the development of technologies in order to remain competitive and achieve good business results. In addition, the development of modern technologies has led to changes in the needs and demands of consumers. As the development of technology led to greater consumer awareness, their changes became more frequent [10]. Given that we live in the time of Industry 4.0 and consumers have become consumers of 4.0. Organizations are forced to change their strategies in order to respond to the demands of consumers. In order to be able to respond to these demands with certainty, organizations must: constantly communicate with consumers, establish themselves as a trustworthy organization by saying what the consumer wants to hear, constantly create new values for consumers, be even faster in recognition their wishes and needs [11].

The extremely high quality of products and services that consumers want is stated as an imperative. Those products must be ecological, more and more attention is being paid to the use of renewable energy sources, etc. In addition to all that, consumers are looking for products and services that will be unique, different, and more original. In order to respond to these demands, organizations require creativity and innovation from their employees, in addition to the skills and knowledge they possess. Through the creativity and innovation of employees, organizations improve their products and services, offer

consumers what they want and thus maintain a competitive advantage [12,13].

### III. INNOVATIVENESS AND CREATIVITY OF EMPLOYEES

People are very valuable in the organization in which they work, because each individual brings with them certain knowledge and experience, which increases during work. Many studies have shown that creativity and innovation exist in every employee, it is only necessary to encourage them [5]. Creativity can be defined as the production of new and useful ideas related to products, services, processes and work procedures [14]. In order to encourage creativity among employees, it is first of all necessary to build a creative work environment. It is such a working environment that most effectively supports the generation of new ideas. The creative work environment is influenced by numerous factors, which can be grouped into four areas [5,15,16]:

- leadership behavior - leaders are the ones who need to encourage creativity, motivate and encourage employees;
- team climate, social interactions and norms - team climate is a reflection of organizational culture and climate. As such, it is manifested in the patterns of behavior, attitudes, beliefs and values that are cultivated in the organization;
- communication and cooperation processes - employees must have excellent communication channels between themselves, in order to share ideas with each other, but communication and cooperation with people outside the organization is also important;
- work and job design - the importance of “good work” plays a significant role in motivating employees' creativity. Therefore, it is necessary for the job to be designed in such a way as to give the employee the autonomy to make decisions, to plan his work, as well as the availability of the necessary resources.

Innovation depends on creativity, which means that organizations should pay attention to the creative potential of their employees and support creativity at work [17]. Therefore, innovation implies the implementation of creative ideas into action. Innovations are a key

factor in the competitiveness of organizations, in particular expressed now at the time of shortening the life cycle of products and rapid development of technologies. It is for this reason that organizations are looking for employees with innovative knowledge. Likewise, they are obliged to organize regular trainings, so that this knowledge does not become obsolete. Employees with sufficient innovative knowledge will more easily participate in the creative process. When employees invest their efforts to identify the problem, obtain as much information as possible, and use their knowledge to engage in the creative process, solutions that are new and useful are more likely to emerge [18,19,20]. Another factor that influenced the need for greater employee innovation was the outbreak of the Covid 19 pandemic. In order for all work not to be neglected, employees had to find innovative ways to keep the business alive. Here too, instead of earlier, reactive innovative action, the need for proactive innovative action arose [21].

The task of organizations is to support innovative and creative employees. A lack of motivation can cause talented employees to avoid job opportunities and not put enough effort into what they do. Inefficient use of talent is a practical waste of resources, which ultimately leads to a lack of creativity, which further entails a lack of innovation and new original ideas. The most important forms of motivation are material rewards, but also support, praise, giving freedom, feedback, etc. [22,23].

#### IV. THE INFLUENCE OF INNOVATIVENESS AND CREATIVITY OF THE EMPLOYEES ON THE SUCCESS OF THE ORGANIZATION

Today's time is a time of rapid and frequent changes. If the organization, as well as all its employees, are not aware of this, not only will the organization not develop further, but it is also doomed to lose its existing market positions. We live in the time of Industry 4.0, in which completely new ways of production appear, where robots become a key element and where ordinary human activities and thinking are trained to be overcome [22]. Increasing levels of automation and the interconnectedness of the digital and real worlds are creating an environment that requires a range of interdisciplinary skills. For the sustainability of the company in this environment, human creativity wins an irreplaceable role. Innovation and open and flexible thinking about necessary changes (proactive introduction of changes) give

organizations a competitive advantage [24-26]. Creative thinking and innovative behavior are exclusively human skills and no artificial intelligence can replace them. The originality of the idea and its implementation is the response of creative and innovative employees to increasingly demanding consumers for specific products and services [27].

Creativity and innovation within well-run companies have always been recognized as a sure path to success. Creative business ideas set companies apart from each other. Without creativity and innovation, every company would follow the same patterns in marketing/promotion, production technology, business methods, and even the products and services it sells [28]. Creativity and innovation are very important to business (for all industries) and the success of organizations. Five reasons why they are important can be singled out and they are shown in Fig. 1. [29].

One of the key success factors in the business of organizations is to attract and retain people

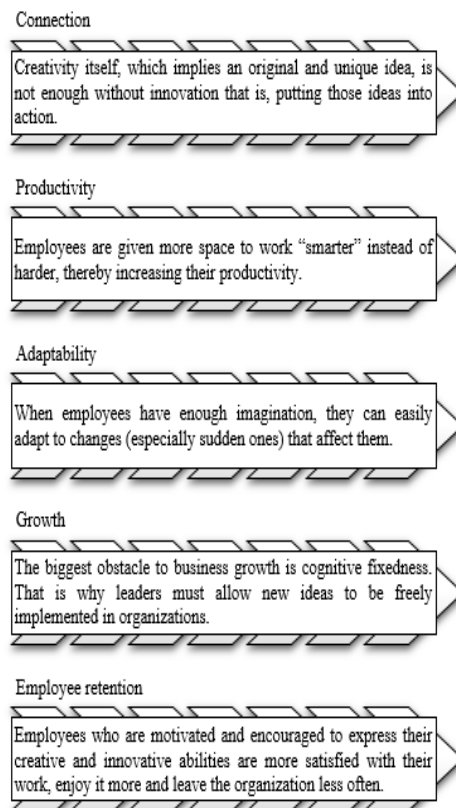

Figure 1. Reasons for the importance of creativity and innovation

who possess creative and innovative abilities. Also, these employees need to create an appropriate working environment, which stimulates creative and innovative behavior [15]. The ability of an organization to support creativity and innovation, as non-repeatable intangible resources, is a key element of competitive advantage. Only organizations that in the future will motivate their employees to be innovative and creative through various types of rewards will be able to survive in the turbulent global market.

## V. CONCLUSION

The tastes and wishes of consumers have changed a lot in today's modern business. In addition to quality, the uniqueness of the product is sought. For this reason, it is very important for employees in modern organizations to be creative and innovative. Another problem that occurs when preventing employees from expressing their innovation and creativity is employee turnover. Precisely because of this, it is the task of leaders (managers) in organizations to encourage and reward creativity and innovation in their employees. In addition to various types of material and non-material motivation, numerous techniques, i.e. interesting exercises, can be used to develop the creativity and innovation of employees. Some of these techniques are: brainstorming, different types of case studies, cross training (getting to know the work done by other colleagues), mind mapping (displaying thoughts and operations using drawings, which synthesizes knowledge and stimulates imagination), scavenger hunt (searching the literature, the Internet all the information in order to arrive at a new solution to the problem) etc.

## REFERENCES

[1] Buntak, K., Martinčević, I., & Mutavdžija, M. (2017). The Influence of Modern Business Environment on Management Changes. In *Proceedings of the ENTRENOVA - ENTERprise REsearch INNOVATION Conference, Dubrovnik, Croatia, 7-9 September 2017*, (pp. 395-404).

[2] Stanišić, S. B., & Prodanović, M. M. (2014). Modern business operations under the conditions of great information mobility. In *Sinteza 2014* (pp. 1028-1031).

[3] Kovač, D., Bakator, M., Kavalić, M., Terek Stojanović, E., Gluvakov, V., & Gaborov, M. (2022). Education and training of employees as influencing factors on business performance. In *Proceedings of the International conference on Information Technology and Development of Education – ITRO 2022* (in press).

[4] Gligović, D., & Novaković, S. (2011). Creativity and innovation in function competitive advantage

[Kreativnost i inovacije u funkciji konkurentske prednosti]. *Naučno stručni časopis za društvene i prirodne nauke – Svarog*, 3, 230-240.

[5] Milosavljević, D., Gluvakov, V., Kavalić, M., Čočkalović, Hronjec, M., & Đorđević, L. (2022). The importance of creative potentials of employees in modern business. In *Proceedings of the XII International Symposium Engineering Management and Competitiveness 2022 (EMC 2022)* (pp. 152-156).

[6] Altagić, M. (2013). Management: a learning organization and modern business [Menadžment: organizacija koja uči i savremeno poslovanje]. *CIVITAS*, (5), 160-177.

[7] Bešić, C., & Đorđević, D. (2009). The development of corporate entrepreneurship as a prerequisite for improving the competitiveness of companies [Razvoj korporativnog preduzetništva kao preduslova za unapređenje konkurentnosti preduzeća]. *Tranzicija*, 10(21-22), 101-110.

[8] Đervida, R., Radosavac, A., & Rodić, V. (2016). Characteristics of modern business [Karakteristike savremenog poslovanja]. *Časopis za poslovnu teoriju i praksu*, 363-373.

[9] Shahzad, K., Bajwa, S. U., Ahmed, F., & Sultani, A. R. (2016). Integrating knowledge management (KM) strategies and processes to enhance organizational creativity and performance An empirical investigation. *Journal of Modelling in Management*, 11(1), 154-179.

[10] eKapija (March 2022). *10 promena u navikama potrošača u 2022. godini - Kako kompanije da se prilagode (10 changes in consumer habits in 2022 - How companies can adapt)*. Available at: <https://www.ekapija.com/business-advice/3608796/10-promena-u-navikama-potrosaca-u-2022-godini-kako-kompanije-da-se>

[11] SAGA (n. d.). *Potrošač 4.0 – Evolucija potrošača kao osnov za evoluciju poslovanja (Consumer 4.0 - Consumer evolution as a basis for business evolution)*. Available at: <https://saga.rs/blog/potrosac-4-0-evolucija-potrosaca-kao-osnov-za-evoluciju-poslovanja/>

[12] Kovač, D., Bakator, M., Terek Stojanović, E., Gluvakov, V., & Gaborov, M. (2022). Knowledge and Creativity of Employees as a Prerequisite for the Success of Digital Entrepreneurship. In *Proceedings of International conference on Applied Internet and Information Technologies – AIIT 2022* (in press).

[13] Hisrich, R. D., & Soltanifar, M. (2021). Unleashing the Creativity of Entrepreneurs with Digital Technologies. *Digital Entrepreneurship Future of Business and Finance*, 23-49.

[14] Sears, G. J., Shen, W., & Zhang, H. (2018). When and why are proactive employees more creative? Investigations of relational and motivational mechanisms and contextual contingencies in the east and west. *Journal of Applied Social Psychology*, 48(11), 59-607.

[15] Stanley, T., Davidson, P., & Matthews, J. (2014). Creative Work Environments and Employee Engagement: Exploring Potential Links and Possibilities. *Zeszyty Naukowe, Uniwersytet Ekonomiczny w Krakowie*, 9(933), 33-51.

[16] Shafique, I., Ahmad, B. & Kalyar, M.N. (2019). How ethical leadership influences creativity and organizational innovation: examining the underlying

- mechanisms. *European Journal of Innovation Management*, 23(1), 114-133.
- [17] Runco, M. A., Shepard, A., & Tadih, H. (2022). How much creative potential is expressed at work? *Journal of Creativity*, 32, 1-7.
- [18] Zheng, L., Wang, Y., Gou, Z., & Zhu, Y. (2022). Effects of managerial coaching on employees' creative performance: cross-level moderating role of a climate for innovation. *Leadership & Organization Development Journal*, 43(2), 211-224.
- [19] Hughes, D. J., Lee, A., Tain, A. W., Newman, A., & Legood, A. (2018). Leadership, creativity, and innovation: A critical review and practical recommendations. *The Leadership Quarterly*, 29(5), 549-569.
- [20] Argote, L., & Fahrenkopf, E. (2016). Knowledge transfer in organizations: The roles of members, tasks, tools, and networks. *Organizational Behavior and Human Decision Processes*, 136, 146-159.
- [21] Zhang, M., & Zhao, Y. (2021). Job characteristics and millennial employees' creative performance: a dual-process model. *Chinese Management Studies*, 15(4), 876-900.
- [22] Balková, M., Lejsková, P., & Ližbetinová, L. (2022). The Values Supporting the Creativity of Employees. *Frontiers Psychology*, 12.
- [23] Özdemir, H. Ö., Kan, M., Doğan, H. G., & Kan, A. (2021). Intrinsic motivation for creativity of agricultural holdings in Kırşehir province of Turkey. *Ciência Rural*, 51(3).
- [24] Davidson, R. (2020). Cyber-Physical Production Networks, Artificial Intelligence-based Decision-Making Algorithms, and Big Data-driven Innovation in Industry 4.0-based Manufacturing Systems. *Economics, Management, and Financial Markets*, 15(3), 16–22.
- [25] Connolly-Barker, M., Gregova, E., Dengov, V. V., & Podhorska, I. (2020). Internet of Things Sensing Networks, Deep Learning-enabled Smart Process Planning, and Big Data-driven Innovation in Cyber-Physical System-based Manufacturing. *Economics, Management, and Financial Markets*, 15(2), 23–29.
- [26] Hawkins, M. (2021). Cyber-Physical Production Networks, Internet of Things-enabled Sustainability, and Smart Factory Performance in Industry 4.0-based Manufacturing Systems. *Economics, Management, and Financial Markets* 16(2), 73–83.
- [27] Kucharčíková, A., Mičiak, M., Bartošová, A., Budžel'ová, M., Bugajová, S., Maslíková, A., & PISOŇOVÁ, S. (2021). Human Capital Management and Industry 4.0. In *Proceedings of International Conference on Entrepreneurial Competencies in a Changing World* (pp. 1-10).
- [28] Fortuna (November, 5., 2018). *The Importance of Creativity and Innovation in Business*. Available at: <https://foru.co.id/blog/2018/11/05/the-importance-of-creativity-and-innovation-in-business/>
- [29] Boyles, M. (January, 25., 2022). Harvard Business School Online. *The importance of creativity in business*. Available at: <https://online.hbs.edu/blog/post/importance-of-creativity-in-business>



# Education for Perception and Interpretation of Reality in the Digital Environment

Branko Marković<sup>1</sup>

<sup>1</sup>Academy for National Security, Belgrade, Serbia

<sup>1</sup>brankomarkovic010@gmail.com

**Abstract**—A contemporary man is not only immersed into digital world of traditional and new media, but also his perceptions and interpretations are built by complex structure of information communication technologies defining not only its position both in digital and real world, but also the capacities for cognition of these realities. Namely, the possibilities of cognition are expanded, but simultaneously the contemporary man becomes more and more object of perception of corporations, government and non-government organizations, the media, and the result of that process are the media and other contents adapted to the needs and based on the prediction of reactions. Education for perception and interpretation of reality in the digital environment is a broader term than education for the interpretation of the media because it includes not only media education, but also education about the whole digital context of functioning media, as well as the social consequences of development of the information communication technologies, related to both a reality and a man.

**Keywords** - education, the media, reality, disinformation, digital

## I. DIGITAL – THE END IN THE DELUGE OR NOAH’S ARK

We live in the biblical times of information flood, Sodom and Gomorrah of media contents, spreading of global disease, viruses and fake news, a clash between good and evil, wizards, heroes, traitors, crime, a blazing light of material wealth from one part of the world and sorrow, dark, sickness and suffering from the other part of the world, global migrations between two poles of happiness. Global digitalization has not only upgraded the whole world, but also enabled

creating new techno-social structure and its hierarchy based on the convergence of social and digital potential of reality perception that brought us closer to those mystic times. Even in the emergence of the digital world its Biblical character can be discerned. Imitating his Creator who created the world from words naming it and giving it a meaning, a man has transformed that world into digital print becoming preferential by counter procedure thus depriving it of its meaning.

If the digital is understood as an upgrade and an extension of human senses, according to McLuhan's theory, then managing that extension would be imperative if one wants reality “not to get away”. But there are many who want to manage that process from economic, political, cultural and maybe even the reasons that go beyond normal and rational.

Newly created digital-social structure created a hierarchy of impact potential on which the way we see the world depends. In other words, it will depend on where we are in this structure whether digital extensions are part of our digital identity or the extensions we think they’re ours, and in fact they are the extensions through which an intensive influence is exerted. When we surf the Internet and download its content, the other people are vigilantly searching our interests, as well as requesting and obtaining permission to access the devices in exchange for using the applications they made. Swimming in the digital waters became automatic, having in mind that we are more and more consciously directed towards warm waters of conformity while cold, sobering,

critical digital waters became unattractive and compromised.

Moreover, the global pandemic of Covid-19 virus resulted in “the changing the paradigm of how we function in the digital world”, that is, imposing “the new digital normal” and the way we work, learn, trade [1]. The restriction of movement caused us to replace the physical meetings, school classes and scientific conferences with virtual ones, and socializing with chatting on social networks. Being forced by the curfew to such behaviour, we discipline ourselves to be continuously exposed to digital technologies.

In such conditions, an individual’s position seems to be hopeless. Surrounded by the contents he wants to see, trapped in information bubbles of political, economic, ideological understandings of “naive realism” [2], he is being boiled as a frog in the self-sufficiency of his importance, because the goal has been achieved, “I appeared online, my voice is heard.” Swimming in the digital world means “to exist”, where the place for existing is not so important at all. The architecture of the digital environment creates new rules and institutional concepts [3].

Voluntary accepting such situation completes the process of power realization, individuals become, not this time extensions of perception, but of realizing the interests of others. A user become taken advantage of, the subject of information and communication almost voluntarily turns into an object. Meaning arises from the omnipresence of digitality, and not from the contents dispatched almost for compromising the idea of any kind of media education, especially having in mind that a part of digital extensions has been moved outside the media frames.

This is why it is very important that education for media or media education broadens from media contents and everything following from it into socially digital structures of perception extensions. Because media education is mostly related to the projected need to disable misinformation or manipulation and propaganda, that is the influence of the media regarding the assumption that the media are dishonest and have hidden agendas. On the other hand, expanded understanding of media education leads to creating capacity of the man of the future for changing the individual's position in the digital social structure, that is creating responsible citizens who are motivated and competent

participants in socio-political life [4]. In that respect media education would include education about the choice and use of media technologies, education about media industries and media contents, as well as media education of the media.

At the same time, it is necessary to respond to numerous challenges of digital environment, beginning with inequality in the progress of digital education and inadequate opportunities for acquiring adaptive skills tailored to the digital world, as well as to overcome limitations in interdisciplinary research [5].

## II. MEDIA LITERACY IN DEFENSE OF REALITY

The process of media convergence is the result of digitalization that is powerful development and interaction of information communication technologies with social structures. The relationship between man and the digital world realized through the technical means is looked through the prism of so-called pre-communication impact stage. Namely, the way itself as well as the conditions or motives for connection with its extensions significantly determine one's perception of the world. Our interests, education, emotional state and other factors determine if we'll see the world through the prism of traditional or new media, Internet, or which applications we'll use and in what way to a great extent.

On the other hand, the same interests and needs are created and delivered on the other side of the digital offering. This is the reason why selecting the way we interact with the digital world or digital means, staying outside the traditional comprehension of media education is so important. If the traditional understanding of media education, among other things, justifiably indicated caution and more careful use of media content, here we raise the question of caution in the use of technical means for connection with the digital world of ideas. By automatically using technical means, one enters a vicious circle and digital reality is accepted as a priority and based on the principle of satisfying needs, it sends one to a long journey into the warm seas of conformity. By using an internet application for communication installed with the permission that such application can access microphone, camera and other parts of the phone, an individual provides personal information that may be of interest to Internet companies in profiling customers of certain products. By downloading

certain contents from the Internet, using the search engines, simultaneously getting information about the subject of their interest, one sends information about oneself and one's needs and current mental and emotional state. In return, Internet companies send, in relation to one's needs, media content and suggestions compatible with the required needs, and so on.

Imposing the digital as a priority does not take place through the content but through use. Accordingly, the first step towards the digital literacy in defense of reality should be education for selective use of technical devices, about circumstances and time of their use, that is, should they be used and to which extent. This emphasizes the exposure and attention, or as Potter would define it, physical, perceptive and psychological exposure as significant factors that determine the process of coupling the senses with digital extensions. Exposure means physical presence of connection devices (smart phones, TV, computer), sensory ability to perceive signals and messages from that device, as well as awareness or ability to place the messages into cognitive maps of meaning and significance. It is important here to emphasize two conditions of the mentioned communicative situation defined by Potter as a state of automatism and a state of paying attention [6].

According to Potter, a state of automatism implies we are in the environment where we are exposed to messages but we are not aware of them. However, we go one step further. There is a state of automatism, that is, exposure and physical contact with devices we are unaware of. Good example of such automatism is video surveillance of public spaces, then TV remote control with voice command on the shelf, mobile phone in the pocket, computer on the living room table, TVs with cameras, etc. An awareness of the technical possibilities of the creeping domination of the digital is necessary in the strategy of protecting the real. A state of automatic exposure to connection devices and messages leads to states of automaticity in giving attention to the events we are surrounded by, where there is a great probability that we would give primacy to mediated or digitalized reality.

Although watching, for example, a match or a sporting event on television is justified by the fact that we cannot attend it due to physical distance or excessive costs, it does not mean there are no matches we can personally attend in our environment.

Breaking the connection, in this case between automated and generated interest and paying attention to the sporting event (information about the time of match, the existence of transfers, betting odds, etc.) which in comparison with the local sporting event around the corner is an event par excellence, wishing to watch it even on television is the first step towards separating an individual from the interests of the football clubs, the media owners, betting shops and its coming back to realistic scope and potentials. Such trivial (we can call it naive as well) example most efficiently reflects the hopelessness of media literacy within the purview of choosing between digital and real world. And this is just the beginning, the question is whether we will have a choice in the future.

Would we prefer face-to-face or telephone contact, would we look flowers, mountains, seas, cultural monuments only through our digital eye, would we inform ourselves only through television, social networks and worry about global problems, at the same time passing by polluted rivers and baskets full of garbage in our immediate environment, it is all matter of choice when and how we use the means of digital extensions. It has already become a question of human identity and supreme decision making on a personal level. When connected to social networks, a man becomes someone else. This is why the question of choice, method and duration of exposure to information communication means becomes a matter of choice between real and projected self.

Of course, one should not draw conclusions from the above statements that a digital technology is an evil that should be avoided. On the contrary, digital technology brings with it numerous benefits, but the "invisible production" must not be allowed the luxury of enslaving preferential reality, according to the principle of a circle enchanted by mystical influences of digital conveniences. Our consent is necessary for that but it should not be given to unlimited exposure to technical devices.

Reticence about using information communication technologies, especially concerning the duration and method of use, considering the appropriate alternatives, assessment of personal capabilities and potentials related to the exposure, that is, the state of automaticity and fiving attention are the main messages of new media education in the defense of the reality, although aware that media



education can be compromised only relating to a false naivety of those messages and “the public paralyzed by cynicism as regards them” [7].

### III. EDUCATION FOR PERCEIVING THE REALITY OF THE MEDIA AND MEDIA REALITY

Media education should not be perceived as the answer to evil technologies and dishonest media. It is primarily focused on the active, critical attitude towards media and digital technologies, digital technologies, media industries and media contents. Perception that the media and means of digital technologies are part of the social construction, reflecting the hierarchical structures of society, being profit oriented, functioning in certain cultural ideological political frameworks, additionally increases the capacities for the mentioned relation. The dynamism of changes in the media industries imposes constant critical efforts for their perception, because knowing how media industries function and with what motives is a part of media education. Ownership structure and media financing, that is, their transparency is significant fact from the aspect of assessing media reliability, information accuracy and their bias. The problem of ownership structure is seen through their non-transparency, as well as consolidation and creation of media conglomerates.

Non-transparency of ownership is a sign that these media are unreliable with extremely questionable contents. On the other hand, the consolidation of ownership and creation of media conglomerates strengthens the clientelistic relations of the media, the most important social topics are created and narrowed down, homogenization is accelerated in the interest of profitability and finally, democratic political processes are endangered [8]. It should not be forgotten that an individual is a part of the identified target group in one way or another, a type of goods sold to advertisers. In this sense, the choice of media and alternative media turns into a choice, will we be a commodity or not.

Knowledge of how media industries function, what their organizational structure is like is also a significant segment of media education. Knowledge of how news is produced, distributed or financed is “consequential civic resource” which increases capacities for orientation in a complex digital environment. Like knowledge about the news system it implies information how important media organizations function and which activities entail production of

the news and media reporting [9]. The aforementioned knowledge also includes knowledge of the cultural, socio-economic and political context of how journalist function, that is, their frame of reference.

Knowledge of media reality, i.e. the ways of constructing symbolic and imaginary reality produced and marketed by the media is the primary subject of media education. Investigation of the nature of mass communications by applying the most various theoretical directions has come a long way from understanding it as the transmission of symbolic contents whose goal is to create certain effect until the construction of symbolic or media reality which confirms or questions a certain social order. Interpretative frameworks carried by social institutions, organizations, interest groups, political parties and individuals create numerous definitions of reality reproduced by symbolic action of the media in the processes of legitimization and delegitimization. Confrontation between different definitions of reality always actualizes the issue of power, as well as the media conditions in which they are implemented. Therefore, the mass media appear as an infrastructure for the objectification of different representations through the process of creating a symbolic construction. Besides constructing reality, the media are also part of that reality [10].

In this respect, the media education is simultaneously education about order, power, hierarchy and structure of the social system. By paraphrasing Berger and Luckmann, understanding of the media is important for understanding reality because they have a capacity to “transcend reality” and thus construct “buildings of symbolic representation” unavailable to everyday experience as “presence from another world” [11].

Framing concept is significant for media education, because it refers to both the coding, that is, semantic structuring of media contents, and the decoding and interpretation of these contents by the audience. It relates not only in the way journalists select the event to be or not to be reported about, or selecting the aspects of these events, but also how will media content structured in this way influence the interpretation and will it have an effect on the public. Media production of meaning is a form of suggesting limited interpretations of these meanings, through manipulative and propaganda

techniques of their construction. Semantic field of recipient's "freedom" is defined by markers with high suggestive potential and the decoding process is controlled in terms of generating and suggesting a certain meaning [10].

Efforts to meet the needs of both the media and the public is the main feature of the mentioned process. Media education in this context also includes knowledge of propaganda techniques and manipulation, media partiality and objectivity in constructing media contents. Media education distinguishes between education for the interpretation of content and communicative situation of traditional and new media. Although the digital convergence of media reduced the possibility of distinguishing them, education for the interpretation of new media, social networks and the Internet has its own specificities.

There are two categories of news indicators on the basis of which its value can be determined, basically original indications (for example, brand news, heading, or accompanying image) and both personal and aggregated signs of social support (for example, a person who posted it and a number of likes, comments and shares) [12].

Self-expression, self-affirmation and self-enhancement motivations are at the core of social media use, as well as social belonging, social learning and social management of impressions and relations through selective self-presentation provided by the technical capacities of social networks [13]. Accordingly, media education of social media cannot be realized without the understanding of the individual and the responsibility of the user.

Consequently, the social practice of creating, distributing and interpreting meaning on social networks through the constructions of authentic realities is a subject of social media education.

The basis of social media literacy is understanding individual motivations for choosing content, social networks and different media.

It should contain knowledge not only about the stable and changing characteristics of various forms of communication and social networks on the Internet, but also about the fact that an individual's interactions with them shape, change and strengthen their perception of reality (literacy).

#### IV. MEDIA EDUCATION FOR THE MEDIA AND SOCIETY

Media education implies creating public capacity for orientation in a complex digital and media environment. It also starts from the fact that media content is not an explicit carrier of meaning, as well as that the media is not always at the service of its audience. However, the speed of technological changes in the media industry is so great that media education is incomplete without the education of journalists and other media professionals in the direction of protecting the original principles of the profession. The attractiveness of the power of the media and the power of conformity in the media strengthens clientelistic relations and turns journalism and the media into weapons for creating anti-publicity. Media education for the media is an integral element of the struggle not only for the media, but also for the meaning and defense of the critical public.

It is a simultaneous effort to increase the group capacity of the community, its values and resistance to all media and other challenges of the modern digital era. It is possible as well that normality will be jeopardized otherwise.

Leaning on the opinions of Benkler, Faris and Roberts and Humprecht, Esser and Van Aelst supposed directions of media education for the media can be defined for the purpose of strengthening capacity of a society and the media as well [14,15].

The media should reduce political polarization in a society. Namely, in polarized environments, citizens are confronted with different deviant representations of reality and therefore find it increasingly difficult to distinguish between false and accurate information [16].

Subsequently, it is necessary to reduce the level of propaganda-populist communication. Societies with a high level of communication are susceptible to the spread of misinformation and inaccurate perceptions of reality [17].

It is necessary to strengthen the trust in professional media which reduces the use of alternative unreliable media. Distrust of the media increases the use of alternative sources, such as online platforms distributing disinformation [18]. Societies in which news users are distributed across a large number of media, some of which are peripheral, offer more entry points for misinformation than societies

where universally recognized media can unify a wide audience in their online and offline offerings, for example because of their high reputation and quality [19]. In this regard, it is necessary to strengthen the capacities of public services, which increases the information of the audience, and promote the limited use of social media in the information process.

## V. CONCLUSION

One should not expect that both the public and the media will understand the significance of media education and that it will be “profitable” for them. Sometimes believing in the illusion about oneself and the height of profit is above the comprehension of the truth. In this sense, the action of the state is necessary in the form of providing the opportunity to educate the public and the media in the common interest through the educational system.

However, the state and media moguls in the digital order become actors that cannot be easily controlled, who have significant control and management mechanisms as well. Gandhian digital resistance in the form of “Cypherpunks” creates the initial letters of the digital alphabet, not only as strategies of resistance and protection, but also creating capacities and advantages of both the individual and the whole society.

The impression is that exposure to the media, media forms and contents are the basic directions of media education of the audience. Research programmes on how to use digital technologies, its length of time of use and the types of these technologies are imposed as preferential in perceiving the influence of the digital exposure on human health, as well as its role in a new social-digital order.

On the other hand, reducing the polarization of society, propaganda communication, strengthening trust in professional media and public service are the basic directions of media education of the media and society. Defining the criterion and exact measurement of the polarization of a society and creating media and other strategies for its reduction are expected directions of future research programmes.

## REFERENCES

- [1] Syamimi Masrani, A., & Nik Husain, N. R. (2022). Digital environment: An evolutionary component in environmental health. *Journal of Public Health Research, 11*(2), 22799036221103125.
- [2] Ross, L., & Ward, A. (1996). Naive realism in everyday life: Implications for social conflict and misunderstanding. *Values and knowledge*, 103-135.
- [3] Addis, A., Saba, M., & Loddoo, O. G. (2021). Social Acts in Digital Environments. *Phenomenology and Mind, (20)*, 64-75.
- [4] Kellner, D., & Share, J. (2019). *The critical media literacy guide: Engaging media and transforming education*. Brill.
- [5] Syamimi Masrani, A., & Nik Husain, N. R. (2022). Digital environment: An evolutionary component in environmental health. *Journal of Public Health Research, 11*(2), 22799036221103125.
- [6] Potter, W. J. (2018). *Media literacy*. Sage Publications.
- [7] Vraga, E., Tully, M., & Bode, L. (2022). Assessing the relative merits of news literacy and corrections in responding to misinformation on Twitter. *New Media & Society, 24*(10), 2354-2371.
- [8] Turow, J. (2013). *Media today: Mass communication in a converging world*. Routledge., New York
- [9] Amazeen, M. A., & Bucy, E. P. (2019). Conferring resistance to digital disinformation: The inoculating influence of procedural news knowledge. *Journal of Broadcasting & Electronic Media, 63*(3), 415-432.
- [10] Marković, B. (2018). *The construction of text in the function of directing the meaning in the contemporary Serbian press*. Unpublished doctoral thesis.
- [11] Berger, P., & Luckman, T. (1991). *The Social Construction of Reality*. London: Penguin Books.
- [12] Messing, S., & Westwood, S. J. (2014). Selective exposure in the age of social media: Endorsements trump partisan source affiliation when selecting news online. *Communication research, 41*(8), 1042-1063.
- [13] Moreno, M. A., Kota, R., Schoohs, S., & Whitehill, J. M. (2013). The Facebook influence model: A concept mapping approach. *Cyberpsychology, Behavior, and Social Networking, 16*(7), 504-511.
- [14] Benkler, Y., Faris, R., & Roberts, H. (2018). *Network propaganda: Manipulation, disinformation, and radicalization in American politics*. Oxford University Press.
- [15] Humprecht, E., Esser, F., & Van Aelst, P. (2020). Resilience to online disinformation: A framework for cross-national comparative research. *The International Journal of Press/Politics, 25*(3), 493-516.
- [16] Craft, S., Ashley, S., & Maksi, A. (2017). News media literacy and conspiracy theory endorsement. *Communication and the Public, 2*(4), 388-401.
- [17] Pennycook, G., & Rand, D. G. (2019). Lazy, not biased: Susceptibility to partisan fake news is better explained by lack of reasoning than by motivated reasoning. *Cognition, 188*, 39-50.
- [18] Tsfati, Y., & Cappella, J. N. (2003). Do people watch what they do not trust? Exploring the association between news media skepticism and exposure. *Communication research, 30*(5), 504-529.
- [19] Fletcher, R., & Nielsen, R. K. (2017). Are news audiences increasingly fragmented? A cross-national comparative analysis of cross-platform news audience fragmentation and duplication. *Journal of Communication, 67*(4), 476-498.

# Open Innovation Paradigm

Vanja Vukojević<sup>1</sup>, Milenko Tanović<sup>2</sup>

<sup>1,2</sup>Innovation Centre, University of Niš, Niš, Serbia

<sup>1</sup>vanja.d.vukojevic@gmail.com, <sup>2</sup>milenkotanovic@gmail.com

**Abstract**—Innovation is mentioned even in Schumpeter’s work from 1934, and it is studied by different world famous scientists like Porter and Drucker. Open innovation is new paradigm that created a new chapter in academic literature, but most important, gave new meaning to the innovation process. The first author who came with the name open innovation is Henry W. Chesbrough, in his book *Open Innovation: The New Imperative for Creating and Profiting from Technology*, from 2003. This new paradigm core is including external ideas for innovation. Not all innovation come from inside of the firm, some of them are given by sources outbound, and later commercialized. Nowadays, open innovation is essential for companies that want to be competitive at the market. This paper shows a brief review of theoretical components of open innovation paradigm, but also the importance of online platforms in innovation process.

**Keywords** – innovation, open innovation, platform, Ideanote

## I. INTRODUCTION

Concept of innovation is present in scientific literature since XX century. Term itself derives from Latin verb for creation. Nowadays, innovation isn’t only about the creation, but also about improvement [1]. According to various authors, innovation is “entrepreneur’s instrument to utilize changes in the environment” [2], “the process of creating something new” [3], or “key ingredient to manage the global competitiveness and companies have to deal with the creation of new products and services [4]. Reference [5] gave complex definition: “Innovation is the multi-stage process whereby organizations transform ideas into new/improved products, service or processes, in order to advance, compete and differentiate themselves successfully in their marketplace”. Other authors emphasized different components of innovation, such as

ideas and value, so “Innovation is the process by which new ideas turn into practical value in the world” [6]. So, we can conclude that innovation is seen as something new, or improved, which comes from ideas and entrepreneurial spirit, and makes greater value in conducting business. Innovation is essential for obtaining competitive advantage, in these dynamic business conditions. Companies need to have the best product and services, to constantly improve production and distribution process. All those innovations earlier came from R&D (closed innovation). Research and development department became one of the crucial parts of every company that wants to be at the top of its industry. However, getting to innovation was complex and difficult. So, in the last twenty years, companies started to search for innovation outside its boundaries, and a new paradigm has arisen.

## II. PARADIGM OF OPEN INNOVATION

The concept that firms should look “outwards” for ideas and knowledge from a broad range of outside sources instead of just “inwards” is known as “open innovation” [7]. Prof. Chesbrough came with this term in his book *Open Innovation: The New Imperative for Creating and Profiting from Technology*. Open innovation assumes that firms can and should use external ideas as well as internal ideas, and internal as well as external paths to market, as they look to advance their innovations [8]. Open innovation has been defined in 2014 by [8] as “a distributed innovation process based on purposively managed knowledge flows across organizational boundaries” [8]. Open innovation refers to how organizations use internal and external sourcing and markets paths for innovation, or share innovation processes [9]. Prior concept of creating innovation inside companies is called “closed innovation”, as an

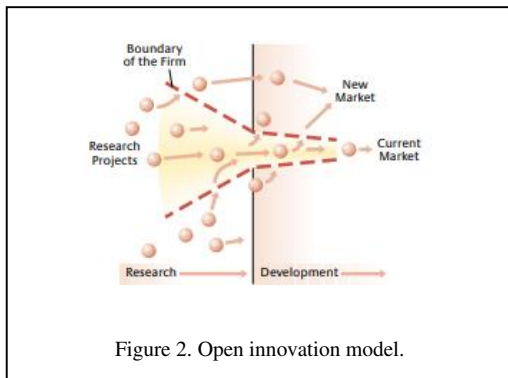
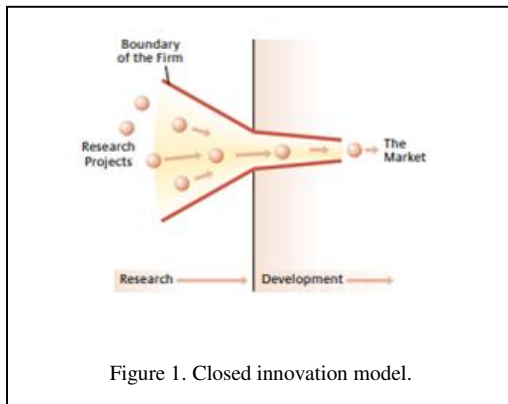

analogy. Figs. 1 and 2 show differences between these two models.

As we can see, in first model, all research projects with the goal of creating innovation are exclusively inside the boundaries of the firm. The main characteristic of the close innovation model is vertically integrated research and development departments that develop technology in-house for use in-house [10]. There are several factors that influenced using open innovation model. First of them was definitely mobility of employees. Workers move from one firm to another, carrying their knowledge and skills. Besides that, collaboration between firms became improved and joint projects became more often.

Open innovation model, on the other hand, has great interaction with environment and innovation cross boundaries of the firm. Firm commercialize ideas given inside the firm boundaries, and others ideas also. The focus for gaining ideas is moved from R&D to outside determinants, such as startups, universities and research centers. Nowadays, thanks to the online platforms, firms can gain new ideas and solution from individuals and institutions all over the world. There are few basic principles of open innovation model:

Not all the smart people work for us, so owe must find and tap into the knowledge and expertise of bright individuals outside our company:

- External R&D can create significant value: internal R&D is needed to claim some portion of that value;
- We don't have to originate the research to profit from it;
- Building a better business model is better than getting to the market first;
- If we make the best use of internal and external ideas, we will win;
- We should profit from others' use of our Intellectual Property, and we should buy others' IP whenever it advances our business model [10].

Open innovation model has various advantages. This is great opportunity for firms to access new sources of idea, more rapid and with less cost. Innovation process is more flexible, involving stakeholders such as suppliers and customers. In that way, output of innovation process, whether its improved product or service, has better quality and it is better fitted for the customers.

Reference [11] gave different collaboration modes during innovation process, using parameters, type of governance and participation openness.

For traditional firms, dominant type of collaboration is elite circle, characterized by closed participation and hierarchical governance. The partner for collaboration is chosen carefully and through this process, one of the partners is authorized for decision-making. Completely opposite is innovation community, as a network where anybody can post problems, offer solutions, and decide which solutions to use [10].

TABLE 1. TYPES OF COLLABORATION.

		Governance	
		<i>Hierarchical</i>	<i>Flat</i>
Participation	<i>Open</i>	Innovation Mall	Innovation Community
	<i>Closed</i>	Elite Circle	Consortium

Innovation Mall is type of collaboration represented by using open innovation platforms.

### III. OPEN INNOVATION PLATFORMS

Open innovation is significant tool for innovation process and it can help companies in various different activities. Open innovation platforms have emerged in various ways [12]. It involves a shift towards more open and distributed models of innovation, while platformization refers to the increasing importance of digital platforms as a venue for value creation and delivery [12]. Large firms, intermediaries, and non-profit organizations are increasingly using online open innovation platforms to leverage external sources [13]. In essence, a platform provides a common foundation and a venue for a wide range of entities to converge in creating and delivering value to their customers [14]. There is vast number of open innovation platforms, according to what problems they solve. Some of them help in finding designers solutions, other help companies to find suppliers or for gathering ideas.

One of the platforms is Ideanote, world's first Innovation-Led Growth platform was founded in 2015 in Denmark, by Mehlsen brothers Fig. 3. Their idea was “to help businesses stay agile and competitive with platform that makes innovation easy to get started with and efficient for everyone” [15]. Since then, they have been cooperating with more than 2000 innovative organizations, such as Ikea and Stanford University, in more than 110 countries.

Founders of Ideanote wanted to facilitate innovation process; this application allows all kind of firms to collect and manage ideas, implement innovation and measure their impact to firm's performances.

For structuring innovation process, company created the framework, called Innovation-Led Growth Flywheel. Framework is consisted of 3P's – purpose, in the center, process, in the inner circle, and people, outer circle. All of this is needed for innovation process to work.

The center of innovation process is purpose. Defining purpose is critical for success of innovation process. Purpose has to be in accordance with the strategic goals of the company. Output of this process has to be



Figure 3. Logo of Ideanote Company.

measurable; it can be decrease in costs or number of implemented ideas.

People dimension represents everyone involved in this process, according to their roles. First of them is initiator. It is someone inside the company, someone senior enough to clear roadblocks [16]. Contributor can be anyone who is willing to cooperate, who is motivated and understands purpose. Depending on purpose, contributor can be internal, external, or both. Diversified teams are the most successful. Evaluators are experts in area connected to the purpose of the process. Stakeholders are people that make collected ideas into factual actions.

As we can see in Fig. 4, there are four phases of this process. First of them is collecting. Collecting ideas is most important phase; it is structured as questions that are being asked to the audacity. Questions have to be formulated as “How might we” [17], for example “How might we decrease transport costs for our product?” Number of questions can vary. Also, audience can be wider or narrower. Next phase is engaging more people, by defining rewards and getting attention of more people. Managing ideas, as the next step, include evaluation of collected ideas and finding the best one. Last step of this process is measuring impacts of this process, by implementing ideas or sharing good results. That is the way for promoting innovation process and making path for the next innovation process.

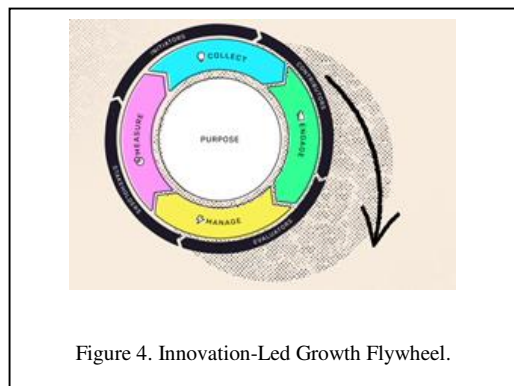

Figure 4. Innovation-Led Growth Flywheel.

This platform has great success. However, there are various other platforms, with different approaches, but with the same goal, to make innovation process more successful by deleting boundaries.

#### IV. CONCLUSION

Innovation is *conditio sine qua non* for obtaining competitive advantage. They are crucial for growth and development of every organization. Companies are aware of importance of innovating, as the form of adjusting to dynamic business environment. Current situation at the employment market has significantly changed the way companies gain ideas and commercialize innovation. Factors such as mobility of highly educated and skilled employees caused rising of the new paradigm. Companies cannot hire every good and qualified employee for their needs. So, they use outsource innovators. Open innovation drastically changed innovation process. Including people outside of the companies in innovation process is giving great results. New ways of collecting ideas and their implementation are being created at this moment. Open innovation platforms are one of them. Further research should include impact of hachatons on business solutions.

This paper has shown basic principles of this new paradigm, with pointing out to open innovation platforms. One of them, Ideanote, has been represented, as a great example of company that makes innovation process easier and faster, by using framework for standardizing innovation process.

#### ACKNOWLEDGMENT

This paper is a result of research based on obligations from the Contract about realization and financing Centre for Innovation, University of Nis (ev.no.451-03-68-68/2020-14/200371), as a part of the Project funded by Ministry of Education, Science and Technological Development no. 179066.

#### REFERENCES

- [1] Vukojevic, V., & Tanovic, M. (2021). Innovation impact in the performance of SME. In *Proceedings of 3rd Virtual International Conference Path to a Knowledge Society Managing Risks and Innovation*.
- [2] Drucker, P. F. (1985). *Innovation and entrepreneurship*. Butterworth-Heinemann, Oxford.
- [3] Sussanto, A. (2017). Improve performance of SMEs through innovation strategies in developing countries. *International Journal of Scientific & Technology Research*, 6(10), 78.
- [4] Farniha, L., Ferreira, J. & Gouveia, B. (2016). Network of Innovation and Competitiveness: A triple Helix case study. *Journal of the knowledge economy*, 7(1), 259-275.
- [5] Baregheh, A., Rowley, J. & Sambrook, S. (2009). Towards multi-disciplinary definition of innovation, *Management decisions*, 47(8), 1323-1339.
- [6] Plan 1: The Case for Innovation Led Growth. NESTA (2012).
- [7] de Jong, S., Oosterveld, W. Th., De Spiegeleire, S., Bekkers, F., Usanov, A., Salah, K. E., Vermeulen, P., Polácková, D., Ward, S., & Skinner, C. (2016). *Better together: towards a new cooperation portfolio for defense*. Hague Centre for Strategic Studies.
- [8] Chesbrough, H., & Bogers, M. (2014). *Explicating open innovation: Clarifying an emerging paradigm for understanding innovation*. New Frontiers in Open Innovation. Oxford: Oxford University Press.
- [9] Öberg, Christina; Alexander, Allen (2019) : The openness of open innovation in ecosystems: Integrating innovation and management literature on knowledge linkages. *Journal of Innovation & Knowledge* 4(4), 211-218.
- [10] Chesbrough, H. W. (2003). *Open innovation: The new imperative for creating and profiting from technology*. Harvard Business Press.
- [11] Pisano, G. P., & Verganti, R. (2008). Which kind of collaboration is right for you. *Harvard business review*, 86(12), 78-86.
- [12] Nambisan, S., Siegel, D., Kenney, M. (2018). On Open Innovation, Platform and Entrepreneurship, BRIE Working paper 2018-5.
- [13] Mokter, H. (2013). Open innovation: So far and a way forward. *World Journal of Science*. 10.
- [14] Evans, D. S. & Schmalensee, R. (2007), The industrial organization of markets with two sided platforms. *Competition Policy International*, 3, 151-179.
- [15] <https://ideanote.io/>
- [16] <https://ideanote.io/chapter/initiators/>
- [17] <https://openinnovation.eu>

# The Role of Innovation Capital in Developing Youth Entrepreneurship

Dragan Čočkalo<sup>1</sup>, Mihalj Bakator<sup>2</sup>, Sanja Stanisavljev<sup>3</sup>, Edit Terek Stojanović<sup>4</sup>, Miloš Vorkapić<sup>5</sup>

<sup>1,2,3,4</sup>University of Novi Sad, Technical faculty “Mihajlo Pupin”, Zrenjanin, Serbia

<sup>5</sup>University of Belgrade, Institute of Chemistry, Technology and Metallurgy - Centre for Microelectronic Technology and Mono-crystals, Belgrade, Serbia

<sup>1</sup>dragan.cockalo@tfzr.rs, <sup>2</sup>mihalj.bakator@uns.ac.rs, <sup>3</sup>sanja.stanisavljev@tfzr.rs, <sup>4</sup>edit.terek@tfzr.rs, <sup>5</sup>worcky@nanosys.ihtm.bg.ac.rs

**Abstract**—The current global economic climate conditions brought challenges to enterprises and entrepreneurs. Uncertainty, higher risk, and intensified competition negatively affect the way business is conducted. Enterprises and entrepreneurs have to adapt to these changes. For economic relief and economic growth, youth entrepreneurship should be developed in a decisive manner. In this paper, youth entrepreneurship development through innovation capital is analysed. The main goal was to identify and discuss main factors that affect youth entrepreneurship development. In addition, entrepreneurship and innovation as two main concepts are also addressed. The result is a theoretical, circular model that provides a significant and concise overview on how innovation capital derives from entrepreneurship and innovation. The paper provides a solid base for future studies.

**Keywords** - youth entrepreneurship, innovation capital, business innovaiton, development

## I. INTRODUCTION

In the new business environment that is characterized by constant changes, enterprises face difficult challenges when it comes to achieving and maintaining a competitive position on the market [1]. In addition, the economic environment brought tremendous pressure to these enterprises that led to decrease in employment rates. Entrepreneurship can be noted as an answer to economic turmoil and unemployment [2]. Entrepreneurship can significantly affect economic development and economic growth. Entrepreneurship is mainly

driven by innovation and risk taking. Further, similarly to entrepreneurship as broader construct, youth entrepreneurship also plays an important role in reducing youth unemployment rates and in creating new value [3,4]. The current body of literature on entrepreneurship and youth entrepreneurship address a wide array of constructs from different aspects of entrepreneurial activities. However, there are fewer studies that address innovation capital in youth entrepreneurship development. Innovation capital can be viewed as past, current, and future innovation potential that derive from intellectual capital within the enterprise where the employees are the main carriers of this intellectual capital. Innovation in this paper includes multiple aspects such as open innovation, business model innovation, technology innovation, and social innovation [5,6]. The main goal of the paper is to present a theoretical model of innovation capital that relies on entrepreneurship and innovation as two main constructs. This way the above noted knowledge gap is addressed. The paper analyzes the complexity of youth entrepreneurship development and the role of innovation capital in this context. Innovation and the aspects of innovation within an enterprise involve processes from all sectors with the goal to create new value. This approach to new value creation coincides with the core concept of entrepreneurial behavior. Therefore, it can be argued that entrepreneurship and innovation capital are complementary constructs for analysis.



The following research questions are noted as guidelines the study:

- *What are the main contributing factors of youth entrepreneurship development?*
- *How does innovation capital affect the development of youth entrepreneurship?*

The paper includes the following sections (excluding the Introduction and Conclusion sections). First, the importance of entrepreneurship and youth entrepreneurship is addressed. The socio-economic impact is noted and the complexity of these social constructs are analyzed. The second section discusses innovation capital and the underlying mechanisms from which innovation capital derives. The third section presents the model for youth entrepreneurship development with innovation capital at the center of the circular model. The fourth section discusses suggestions and guidelines regarding actions and strategies for improving youth entrepreneurship development in the context of innovation capital. These suggestions are based on the analyzed literature and developed model presented in the previous section. Finally, conclusions are drawn and ideas for future research are noted.

## II. IMPORTANCE OF ENTREPRENEURSHIP AND YOUTH ENTREPRENEURSHIP

In the Introduction section it was noted that entrepreneurship positively affects economic growth and economic development [3,4,5]. Entrepreneurship ecosystems and platforms include policies, markets, human capital, government support, culture, and finance [7]. Digital entrepreneurship systems can provide the necessary outreach to latent and potential entrepreneurs. It can be argued that digital entrepreneurship ecosystems can provide adequate stimulation for the youth to start their own business [8]. Further, entrepreneurship and development in socio-economic and political aspects contribute to youth entrepreneurship development as well. Young entrepreneurs should take into consideration the changes that globalization has brought and the rising importance of social aspects of business [9]. From here, the concept of social entrepreneurship gains traction. Social entrepreneurship is in-sync with sustainability goals. Its aim is to shape the process conducting business in way that contributes to local communities, to the saving of the environment, reducing the negative impact of business

activities. Young entrepreneurs should nurture a sense of social entrepreneurship even though their business model is not mainly focused on social issues [10,11]. Therefore, new entrepreneurial endeavours should address sustainability issues. Furthermore, as the globalization of markets has brought dynamics changes to the market, venture lifecycles vary significantly forcing new entrepreneurs into riskier than normal actions. Venture lifecycles are a new strategic liability for existing and new entrepreneurs [12]. Previous studies noted that one of the main factors of reluctance to start own business among the young are lack of financial resources [4,5]. The issue of entrepreneurial finance is present in the majority of economies and it presents a systematic problem in the domain of entrepreneurial activities [13]. Crowdfunding entrepreneurial ideas is a concept of group investments based on ideas of projects (products or services) where the risk of failure is taken on by the whole community of investors (participants in the crowdfunding) [14]. These types of “democratization” of entrepreneurial finance have to actively govern funds and appropriately disclose how the funds are managed [15].

From the aspect innovation and innovation capital, entrepreneurship and youth entrepreneurship can be viewed as drivers of innovative activities and creating new value through the process of innovation. Innovation ecosystems coincide with entrepreneurial ecosystems. The current global business environment focuses on sustainability, thus entrepreneurial and innovation ecosystems should also focus on sustainable development and sustainable business strategies [16]. Innovation capital is a driver of youth entrepreneurship, and larger integrated wholes of innovation capital possess larger capacity and potential for successful entrepreneurship ventures.

Overall, entrepreneurship is an active part of the new economy that is characterized by innovation, globalization, intensified competition, rapid technological advancement, and the digitalization of business. In such conditions, starting a new business requires multiple approaches to evaluating the external and internal business environment. Youth entrepreneurship development is a complex challenge both on a national and local level.

### III. INNOVATION CAPITAL

The framework of innovation management and entrepreneurship development involves the utilization of knowledge, experience, risk taking, and preparedness to conduct business with high levels of uncertainty. New start-ups face challenges in the form of lack of optimal funding, intense competition, and lack of adequate support from third parties (government, suppliers etc.). Established enterprises especially that with multiple stakeholders, have to effectively manage and balance between stakeholder interests and risk taking through innovative approaches to conducting business [17]. Modern business models should focus on innovation niches in evolving open innovation ecosystems [18]. Open innovation can contribute to economic growth, productivity, new products and services, sustainable development, business model innovation and overall new business ventures [19,20]. Therefore, it is evident that such innovative activities support entrepreneurship and that they are complementary with entrepreneurial risk taking and activities. Furthermore, the concept of social entrepreneurship is synchronized with social innovation [21] and as such provide important driver point of youth entrepreneurship development. Social innovation is taken on a new form with the COVID-19 pandemic. More precisely, the digitalization of social innovation and social entrepreneurship have brought a new dimension how business is conducted. In such conditions, online business models are prevailing compared to traditional business strategies [22].

Innovation capital also includes product innovation and the entrepreneurial effect of innovations disrupting industries and influence existing and new enterprises [23]. With new products and services, innovation within entrepreneurship is present through the mediating role of business model innovation [24]. In other words, business model innovation is a kind of a prerequisite for entrepreneurial innovation to occur. Post-COVID-19 business model innovation should consider re-evaluating the lean concept approach. This new lean approach has to be more resilient compared to the previous setups that were present, in order to reduce bottlenecks in crisis times [25].

Entrepreneurial ecosystems alongside with innovation ecosystems can form an environment where entrepreneurship, and especially youth entrepreneurship can thrive [26]. Innovation in

technology can be a challenge and opportunity at the same time, depending on what activities are planned within an enterprise, and which industry is the enterprise in.

In sum, innovation capital, as an integrated whole that consists of multiple business and socio-economic factors including, but not limited to intellectual capital, human resources, infrastructure, R&D activity intensity, proneness to risk taking, and willingness to disrupt markets with new value and new ideas.

### IV. MODEL FOR DEVELOPING YOUTH ENTREPRENEURSHIP

Based on the analysed literature and the aim of this paper, a model for developing youth entrepreneurship within the framework of innovation capital, is developed. The model is circular and it has innovation capital at its centre and two main concepts derive from it: entrepreneurship and innovation. The model is presented on Fig. 1. The concept of the model is in accordance with models presented by the World Economic Forum [5].

Based on the presented model on Fig. 1, it can be seen that innovation capital, in this case, derives from the concept of entrepreneurship and concept of innovation. In this sense, innovation capital is viewed as the result of entrepreneurial behaviour and innovation-based constructs. Entrepreneurial systems and infrastructure are key factors for entrepreneurship development. In addition, the concept of social entrepreneurship, venture lifecycles, finances, and entrepreneurs themselves are integral parts of the entrepreneurship construct. On the other side, innovation, as a part of innovation capital includes business model innovation, open innovation, social innovation (which is in-sync with social entrepreneurship, technological advancement and innovation, and the necessary underlying infrastructure and ecosystem for innovative behaviour.

### V. SUGGESTIONS AND GUIDELINES

Based on the analysed literature in the domain of entrepreneurship, youth entrepreneurship, innovation capital, innovation ecosystems, entrepreneurial finances, and social entrepreneurship, the following suggestions and guidelines for improving youth entrepreneurship development are noted:

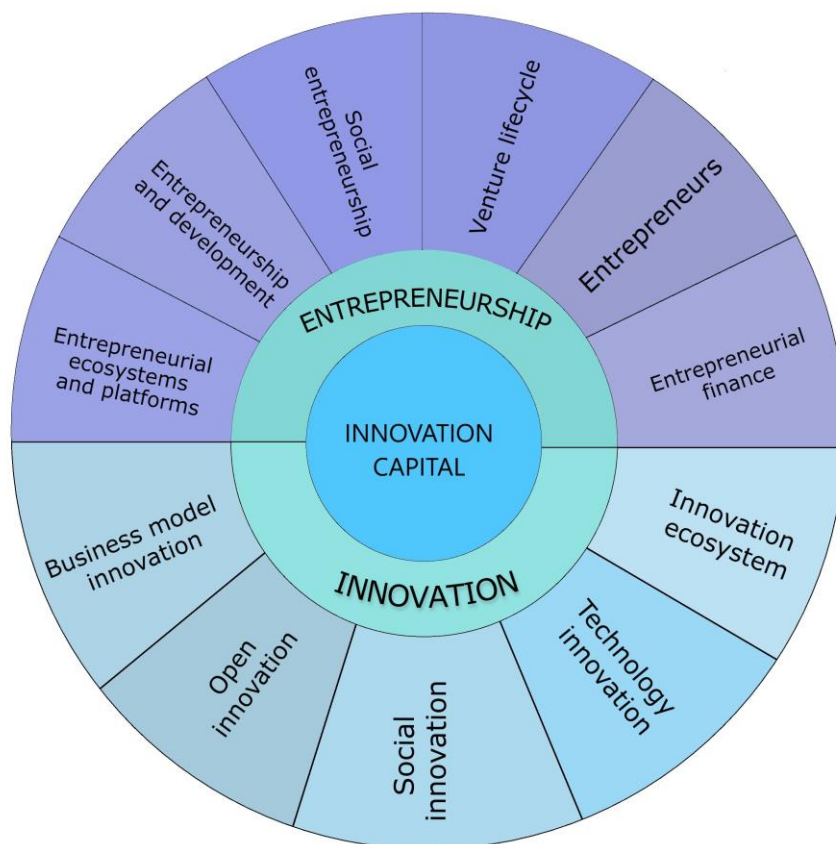

Figure 1. Youth entrepreneurship development model through innovation capital

- New entrepreneurs should focus on creating value and bring innovation into their business model.
- Innovation capital has to be addressed when evaluating market position or potential new market entrance.
- Youth entrepreneurship should be based on value creation in the digital entrepreneurship ecosystem where start-up costs are typically lower compared to traditional business ecosystems.
- Support via incentive programs should be introduced on a national scale.
- Innovation should be rewarded both in newly established enterprises and in existing enterprises. Rewards should be in the form of favourable tax rates, credit lines, infrastructure support and other means of promoting and sustaining innovation and innovative behaviour among young entrepreneurs.
- Open innovation environment along with social innovation and social entrepreneurship should be considered by the youth when starting their own business.
- Innovation capital has to be taken seriously by individual entrepreneurs as well by institutional players (entrepreneurship in organizations).

Overall, youth entrepreneurship development requires a systematic approach on a national level, but innovation has to be taken seriously as a contributing factor to business success. Innovation has the potential to win against well-established organizations that present an intense competition on the globalized market.

## VI. CONCLUSION

In the Introduction section of the paper, two research questions were noted:

- *What are the main contributing factors of youth entrepreneurship development?*

In accordance with the analyzed literature it can be concluded that entrepreneurial finance, entrepreneurship ecosystems, social innovation and social entrepreneurship, technology innovation, open innovation, and innovation ecosystems contribute to youth entrepreneurship development.

- *How does innovation capital affect the development of youth entrepreneurship?*

Innovation capital as an integrated whole of multiple constructs, provides a driving force of entrepreneurial activities and vice-versa. In addition, innovation capital can increase the potential of new youth entrepreneurship endeavours. It can provide necessary support and motivation for starting a new business.

The main limitation of this paper is the lack of an empirical data and a robust data set obtained both from enterprises and entrepreneurs. However, as the study addresses credible literature sources, this limitation is not severe. The paper contributes to the existing body of literature and provides an appropriate basis for future research. Future studies could include surveying existing entrepreneurs, new entrepreneurs, and potential new entrepreneurs. The datasets could be compared with previous studies and thorough meta-analysis could be accomplished.

## ACKNOWLEDGMENT

This paper has been supported by the Provincial Secretariat for Higher Education and Scientific Research of the Autonomous Province of Vojvodina, number: 142-451-2706/2021-01.

## REFERENCES

- [1] Bakator, M., Đorđević, D., & Čočkalović, D. (2019). Developing a model for improving business and competitiveness of domestic enterprises. *Journal of Engineering Management and Competitiveness (JEMC)*, 9(2), 87-96.
- [2] Rajković, J., Mali, P., Mitić, S., Kuzmanović, B., & Nikolić, M. (2020). Comparison of entrepreneurial intentions among students and employees. *Journal of Engineering Management and Competitiveness (JEMC)*, 10(2), 116-126.
- [3] Djordjevic, D., Cockalo, D., Bogetic, S., & Bakator, M. (2021). Modelling youth entrepreneurship intentions: A ten-year research. *Journal of East European Management Studies*, 26(4), 617-760.
- [4] Djordjevic, D., Cockalo, D., Bogetic, S., & Bakator, M. (2021). Predicting Entrepreneurial Intentions among the Youth in Serbia with a Classification Decision Tree Model with the QUEST Algorithm. *Mathematics*, 9(13), 1487.
- [5] World Economic Forum – WEF (2022). *Intelligence topics*. Available at: <https://intelligence.weforum.org/topics/a1G0X000006NwW8UAK/key-issues/a1G0X000006NwiKUAS>.
- [6] Mishra, D. R. (2017). Post-innovation CSR performance and firm value. *Journal of Business Ethics*, 140(2), 285-306.
- [7] Cavallo, A., Ghezzi, A., & Balocco, R. (2019). Entrepreneurial ecosystem research: Present debates and future directions. *International Entrepreneurship and Management Journal*, 15(4), 1291-1321.
- [8] Sussan, F., & Acs, Z. J. (2017). The digital entrepreneurial ecosystem. *Small Business Economics*, 49(1), 55-73.
- [9] Saebi, T., Foss, N. J., & Linder, S. (2019). Social entrepreneurship research: Past achievements and future promises. *Journal of Management*, 45(1), 70-95.
- [10] Stephan, U., & Drencheva, A. (2017). The person in social entrepreneurship: A systematic review of research on the social entrepreneurial personality. *The Wiley handbook of entrepreneurship*, 205-229.
- [11] Tiwari, P., Bhat, A. K., & Tikoria, J. (2017). An empirical analysis of the factors affecting social entrepreneurial intentions. *Journal of Global Entrepreneurship Research*, 7(1), 1-25.
- [12] Patzelt, H., Preller, R., & Breugst, N. (2021). Understanding the life cycles of entrepreneurial teams and their ventures: An agenda for future research. *Entrepreneurship Theory and Practice*, 45(5), 1119-1153.
- [13] Cumming, D., & Groh, A. P. (2018). Entrepreneurial finance: Unifying themes and future directions. *Journal of Corporate Finance*, 50, 538-555.
- [14] Cumming, D., Meoli, M., & Vismara, S. (2021). Does equity crowdfunding democratize entrepreneurial finance? *Small Business Economics*, 56(2), 533-552.
- [15] Marcon, A., & Ribeiro, J. L. D. (2021). How do startups manage external resources in innovation ecosystems? A resource perspective of startups' lifecycle. *Technological Forecasting and Social Change*, 171, 120965.
- [16] Nylund, P. A., Brem, A., & Agarwal, N. (2021). Innovation ecosystems for meeting sustainable development goals: The evolving roles of multinational enterprises. *Journal of Cleaner Production*, 281, 125329.
- [17] Leonidou, E., Christofi, M., Vrontis, D., & Thrassou, A. (2020). An integrative framework of stakeholder engagement for innovation management and entrepreneurship development. *Journal of Business Research*, 119, 245-258.
- [18] Xie, X., & Wang, H. (2021). How to bridge the gap between innovation niches and exploratory and exploitative innovations in open innovation ecosystems. *Journal of Business Research*, 124, 299-311.

- [19] Surya, B., Menne, F., Sabhan, H., Suriani, S., Abubakar, H., & Idris, M. (2021). Economic growth, increasing productivity of SMEs, and open innovation. *Journal of Open Innovation: Technology, Market, and Complexity*, 7(1), 20.
- [20] Pichlak, M., & Szromek, A. R. (2021). Eco-innovation, sustainability and business model innovation by open innovation dynamics. *Journal of Open Innovation: Technology, Market, and Complexity*, 7(2), 149.
- [21] Adro, F. D., & Fernandes, C. (2021). Social entrepreneurship and social innovation: looking inside the box and moving out of it. *Innovation: The European Journal of Social Science Research*, 1-27.
- [22] Scheidgen, K., Gümüşay, A. A., Günzel-Jensen, F., Krev, G., & Wolf, M. (2021). Crises and entrepreneurial opportunities: Digital social innovation in response to physical distancing. *Journal of Business Venturing Insights*, 15, e00222.
- [23] Zheng, L. J., Xiong, C., Chen, X., & Li, C. S. (2021). Product innovation in entrepreneurial firms: How business model design influences disruptive and adoptive innovation. *Technological Forecasting and Social Change*, 170, 120894.
- [24] Ferreras-Méndez, J. L., Olmos-Peñuela, J., Salas-Vallina, A., & Alegre, J. (2021). Entrepreneurial orientation and new product development performance in SMEs: The mediating role of business model innovation. *Technovation*, 108, 102325.
- [25] de Faria, V. F., Santos, V. P., & Zaidan, F. H. (2021). The Business Model Innovation and Lean Startup Process Supporting Startup Sustainability. *Procedia Computer Science*, 181, 93-101.
- [26] Cantner, U., Cunningham, J. A., Lehmann, E. E., & Menter, M. (2021). Entrepreneurial ecosystems: a dynamic lifecycle model. *Small Business Economics*, 57(1), 407-423.

# Development through Social Entrepreneurship: Perspectives and Evidence from Croatia

Tihana Sudarić<sup>1</sup>, Ivana Hrg Matušin<sup>2</sup>, Jadranka Deže<sup>3</sup>

<sup>1,2,3</sup>Faculty of Agrobiotechnical Sciences Osijek, University of J.J. Strossmayer in Osijek, Osijek, Croatia

<sup>1</sup>tsudaric@fazos.hr, <sup>3</sup>jdeze@fazos.hr

**Abstract**—Social entrepreneurship is important segment of corporate social responsibility (CSR) and one of the strategic aims in Strategy of social entrepreneurship development from 2015-2020. This form of entrepreneurship contributes to the local community development by creating new jobs, more specifically those that improve the quality of individual's life. This is especially important for people with disabilities. The aim of this study is to research the presence, frequency and application of social entrepreneurship concept and its effects on local development. The empirical part of the paper is based on a random selection survey. The results confirm the presence of good entrepreneurial practice in the form of integrative workshops in Croatia, their business sustainability and development orientation.

**Keywords** - social entrepreneurship, integrative workshop, local development

## I. INTRODUCTION

The Republic of Croatia, as European Union country is committed to achieve the common goals of the Strategy Europe 2020 by combining action on national and European level. One of the five strategic goals of Europe 2020 is to poverty reduction&social exclusion, and increasingly important global and European strategies are defining their economic goals in relation to these guidelines. Croatia has done the same, as adopted by the Social Entrepreneurship Development Strategy, recognizing that social entrepreneurship is precisely the change in the society we want to achieve and contribute to self-employment, employment and economic growth and development.

Sustainability development via responsible innovation combines philanthropic and economic aspects that refer to entrepreneurs who lead to “social entrepreneurs”. Unlike common innovations, the responsible innovation is the result of various reasons or sources of inspiration that influences the decisions of creativity of entrepreneurs to conduct and generate innovations to solve problems of the society. Interestingly, entrepreneurs seeking to create social ventures are found to have higher levels of entrepreneurial self-efficacy and more ambitious goals than their commercial counterparts. In Europe the dominant discourse about responsible innovation focuses on the control of the risk of social rejection of the advance of science and technology. Opposite, as it is in Mexico, the phenomenon is configured as the mechanism through which entrepreneurs articulate its technological and scientific capabilities to solve priority and specific problems of the society, however, the social impact does not crucially affect their business initiatives [1].

According to [2] the research was conducted in order to identify the factors that have the greatest impact on the establishment of social enterprises in the Republic of Serbia. It was found that favorable financial resources are key stimulants for the establishment of social enterprises. Results also show that enthusiasm of managers of social enterprises has the greatest impact on their development. Also, legal regulations and the macroeconomic environment, as well as difficulties in accessing the market, are serious restrictions to the

establishment of social enterprises, while lack of knowledge in the field of marketing and management limit the development of social enterprises. Measures have been proposed to economic policymakers in the direction of mitigating the negative effects of disincentive factors and strengthening the effects of factors that positively affect the development of social entrepreneurship.

The scientific significance results [3] find out that in social entrepreneurship's development critical role is financial risk. The potential of social entrepreneurship's development in emerging economies is implemented (in 2021 only by 50% because of the restraining influence of financial risks. In case of the optimal management of financial risks (minimalization), the level of social entrepreneurship's development in emerging economies will approach a maximum, which will reduce their underrun from developed countries in the sphere of implementing Sustainable Development Goals (SDGs) and support global sustainable development.

This research and analysis show the manner and structure of socially responsible entrepreneurship. The example of socially responsible companies Hedona Ltd. from Križevci was investigated whether there is a possibility of long-term sustainability, growth and development of such an enterprise and what is the contribution to the local community, local development and recognition of local identity. Sustainability by itself means harmony with environmental, social and economic needs - the three pillars of sustainability.

The aim of the paper is to define the way and structure of socially responsible entrepreneurship, through scientific and professional theories, but also in the applied sense, on the example of Hedona Ltd. from Križevci. The conceptual and research part will highlight the purpose, advantages and current challenges in practice as well as measures and recommendations for further entrepreneurial development in the function of sustainable development.

## II. MATERIAL AND METHODS

Five groups of research methods were used in the paper:

- a) Studying the available literature on sustainable development and integrative

workshops, and their specificities and perspectives. Available data were collected from scientific papers, books, proceedings and internet sources. Those methods of data collection, research and study of available literature on a given topic of collecting data describes socially responsible entrepreneurship;

- b) Case study method based on good entrepreneurial practice at Hedona Ltd. - chocolatiers, one of three integrative workshops in Croatia, as well as information on the production, processing, employees, the workplace structure, and other documentation;
- c) Two surveys were formed: the first one for analysing the internal structure: interpersonal relationships, current business situation and future expectations. The second survey was conducted to research public perceptions via an internet survey, more specifically - Facebook and E-mail was used for the recognition and sustainability of the hedonic's integral workshop;
- d) Comparative method - comparison of data on the characteristics of socially responsible entrepreneurship between the Koprivničko-križevačka County and other counties in the Croatia, between the case study of Hedona and similar case studies examples in Croatia, based on the data collected;
- e) SWOT analysis of the company Hedona – as a method which is used for identifying a internal origin: the strengths and weaknesses, also a external origin: opportunities and threats, important to the sustainable development of the company.

## III. RESULTES AND DISCUSSION

In the last twenty years, corporate social responsibility, CSR - has been increasingly applied in practice, which is still recognizable only by the rare examples of good entrepreneurial practice. According to the reference [4] with the increasing number of market competitors and the increasing customer demands for better services and products, there is a noticeable increase in awareness of the necessary changes regarding access to nature

and the community. The original practice of socially responsible entrepreneurship in Croatia was mainly related to the protection of the environment, while in the second, later phase, interest included human resources and care for the local community.

The application of social responsible entrepreneurship in Croatia is still more an exception than the rule of business behaviour. There are two main reasons for the lack of application the socially responsible entrepreneurship:

- a) lack of definition of criteria that are often interpreted superficially;
- b) insufficient education of leadership and professional services in business organizations in order to carry out the social responsible entrepreneurship activities.

Social entrepreneurship based on decision making, involves strategic planning and investing in long-term prosperity. Social responsible entrepreneurship is used to increase the reputation, environmental preference of the company, stakeholder motivation, to all employees and consumers, which ultimately results in a return on investment, but not always in the short term [5].

For the first time corporate social responsibility as practice is mentioned more seriously in the Croatia, in December 2004, when the first international conference on corporate social responsibility was held in Croatia, attended by more than 150 representatives of companies, business associations, government, professional organizations, academic community and non-governmental organizations. Agenda 2005 was adopted, defining the main areas of activity and possible improvements in the socially responsible practices of Croatian companies; the proposal for establishing a Community for Corporate Social Responsibility (CSR) within the Croatian Chamber of Commerce was highlighted, as well as the proposal to develop a methodology for assessing and evaluating corporate socially responsible and sustainable practices CSR Index, explains [6].

Furthermore, in November 2009, according to reference [7] a conference on social entrepreneurship was held in the Croatia, organized by the Office for Associations of the Government of the Republic of Croatia and the

British Council. The aim of this conference was to promote social entrepreneurship in the Republic of Croatia by introducing public, non-governmental, non-profit and business sector organizations to the principles and models of social entrepreneurship.

The following institutions are most active in promoting social responsible entrepreneurship in Croatia: the Croatian Chamber of Commerce, the Croatian Employers' Association and the Croatian Business Council for Sustainable Development, together with their partner organizations, who are constantly striving to develop competencies for corporate social responsibility and sustainable development by organizing various trainings, seminars and educational courses on the subject, and publish quarterly newsletters and publications to inform and educate the public on these topics.

In addition, since 2007, My Business Portal to the United Nations Development Program, with the Fund for the Professional Rehabilitation and Employment of Persons with Disabilities and the Croatian Employment Service, have been awarded the - Employer of the Year for Persons with Disabilities [8].

According to the reference [9] this kind of rewarding has a goal to increase the number of available jobs for persons with disabilities by providing professional support to employers and promoting the employment model for persons with disabilities according to their competences.

The form of integrative workshops is an example of the active involvement of persons with disabilities in various forms of economic activity. An integrative workshop is an institution or company that employs people with disabilities based on the findings and opinions of a professional rehabilitation center, which has determined that, due to their disability, they can achieve from 30% to 70% of expected work efficiency (Ordinance on protective workshops and integrative workshops for the employment of persons with disabilities, Ministry of Labor and Pension System Official Gazette 75/18) [10]. Integrative workshop should have employed at least 40% of persons with disabilities in relation to the total number of employees. These employees need to be provided with the professional support, supervision and guidance of the professionals working. Because of that integrative workshop has expert workers and instructors for work activities. In relation to the previous, integrative



workshops are obliged to allocate at least 75% of the realized profit to increase the share capital of the company or to use it for investments in fixed assets related to the work of the disabled person, improvement of working conditions for employed persons with disabilities, education, training and other developmental purposes for increase in employability of people with disabilities. There are currently three integrative workshops in Croatia:

- a) integrative workshop for the production of linen, work wear and protective clothing for catering, industry and medicine - Labtex Ltd. from Zagreb;
- b) integrative workshop for production of chocolatier product - Hedona Ltd. Križevci;
- c) integrative workshop for textile production and delivery services, professional cleaning and washing, and machining of high quality textiles used in industry, health, hospitality and gastronomy - Krokoteks Ltd. from Sv. Ivan Zelina.

The conditions for establishing an integrative workshop are complete documentation prescribed by the Regulations. The legal form is a limited liability company that has employees with disabilities and an office that is designed and equipped in accordance with building standards. According to this Regulations, it is necessary to provide persons with disabilities and reduced mobility access to the building. Special care is needed with regard to health and safety at work. The work space should be appropriately equipped and technically adapted to the type of employed persons disability in order to enable work adequate to their abilities. According to the Regulations, Article 24, a professional manager should provide professional support, supervision and guidance to persons with disabilities in the performance of their duties. The task of a professional manager is to monitor the work of persons with disabilities and to recognize their ability to doing business activities. In addition, all employees with disabilities are registered with the Croatian Pension Insurance Institute.

For the purposes of this research, with the aim of introducing more detailed vision and mission, one of the three integrative workshops in Croatia was singled out - Hedona Ltd. – chocolate. Two surveys were conducted: one

with employees in the company and another one for search the public opinion.

The survey on employees conduct: business structure, interpersonal relationships, employees' attitudes about the company's current status and their expectations for the business future. The database was created by collecting information from 14 out of 18 employees. In Hedona, more than half of the total number of persons in employment are persons with disabilities. The business status of Hedona - as integrative workshop, enables it to sale and purchase contracts with other business partners. There is an obligation in the law that every registered company must employ at least one disabled person. In a situation where the company has no employed person with disabilities can instead of paying must have a contract and buy products from companies such as Hedona. Social entrepreneurship, more specifically social entrepreneurs, are an inspiration to many others in driving social change. Through social entrepreneurship lots of social changes are realized - such as business entities that are equally market competitive as well as more oriented to the development of the social and local community. Such a business entity is more focused on social effect rather than profit that can be the accelerator of positive change in society.

The second survey concerning public opinion is conducted on a total of 110 respondents aged from 18 to 56. It was found out that the public was mostly familiar with the definition and main determinants of social entrepreneurship, which they supported by their answers defining the term.

At the same time, respondents are familiar with the goals of sustainable development, and most often they care about the future, the well-being of society, care for the environment, the balance of social, environment and economic factors, which confirms social awareness (Fig.1.).

Regarding the recognition of Hedona in public, the majority of respondents answered that they had heard of the company, but a large number of respondents did not know that Hedona was one of the three integrative workshops in the Republic of Croatia or did not even know what the term represented (41.28%). Based on the application of all research methods, an analysis of the strengths, weaknesses, opportunities and threats (SWOT) was made of

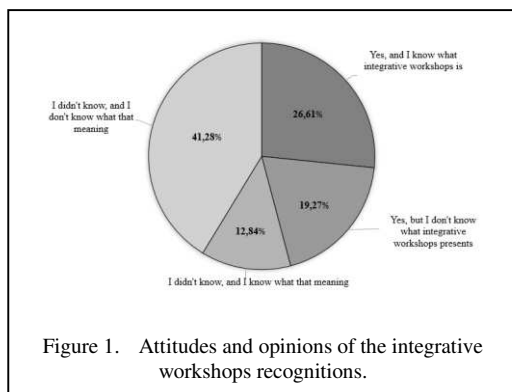

Figure 1. Attitudes and opinions of the integrative workshops recognitions.

Hedona, chocolate factory from Križevci (Table I).

The results of the analysis determined the strengths (S) that should be actively and used to reduce the risks of potential threats (T). At the same time, the realization of the opportunities (O) creates a high probability that the weaknesses (W) will be reduced in the future

TABLE I. SWOT ANALYSIS OF HEDONA LTD. FROM KRIŽEVCI.

	<i>Helpful – to achieving the objective</i>	<i>Harmful – to achieving the objective</i>
<i>Internal origin – attributes of the business</i>	Strengths (S)	Weaknesses (W)
	Quality raw material, Unique product - for all ages, Top quality products, Satisfied and motivated employees, Second integrative workshop in the Croatia, Social enterprise, Cooperation with local and state government, Reinvesting profits to create new jobs, Choco bar.	Too small production facilities, Few places to sell, Poor promotion, Lack of a manager-management, New projects, Research and development, Allergists and diabetics person.
<i>External origin – attributes of the environment</i>	Opportunities (O)	Threats (T)
	More manifestations in Croatia, More manifestations in other countries, The entrepreneurial spirit, Education, Hotel sectors, Expansion of production facilities, Capacity building, Innovations in the product range – e.g. chocolates for diabetics.	Competition, Similar products at lower prices, Lack of educated and motivated workforce Lack of entrepreneurship enthusiasm and motivation.

period of the business of Hedona, a chocolate factory from Križevci.

During the research it was found that the local government has motivated the founders of the company to establish an integrative workshop with continued support in the founding process.

Social focus is also recognized in the process of reinvestment from the profit to improve the production process and working conditions. Based on the research, it is concluded that the concept of social entrepreneurship is more present in business Croatian practice. Local communities are aware of the benefits that come with the introduction and implementation of social entrepreneurship, such as: company reputation, better business efficiency, employee motivation and satisfaction, competitiveness and market recognition. In practice, businesses to implement or add to their strategic business plans is very rare. For more intensive development, it is necessary to emphasize more often the examples of good entrepreneurial practice in the social entrepreneurship segment, especially the form of integrative workshops. Investing in human resources development, additional training and workshops on human resources, technological development, consumer care and environmental protection are guidelines that should contribute to more of these businesses.

#### IV. CONCLUSION

Economic entities have the basic long-term objective of realizing the sustainability, growth and development of a business in a market economy. With the development of the national economy, there is a need for changes in the business of the company. The way of thinking, planning, leadership and managing a business is changing. The business orientation towards economic requirements is added by the concern for environmental protection and social needs of the community. It is necessary to achieve all the goals of the business and the social community in which the business is conducted - economic, environmental and special social. The sustainable business is no longer the main goal of the entrepreneur, but rather the survival of the local and the entire community. After that, we can expect an increase in the number of such economic entities, the development of the quality of their products and the development of competitiveness in general. Example of social

entrepreneurship and an integrative workshop, Hedona contributes to the employment goals of persons with disabilities, which is defined in national legislation as well as in the Europe 2020 strategy document. It is important to emphasize that in this integrative workshop persons with disabilities work in the entire production process with high technological and hygiene standards. Employees with disabilities are involved in all parts of the work process from preparation to production, production of the full range of chocolate products and preparation of finished products for the market. Such integrative workshops are an example of good social entrepreneurial practice because they contribute to the life needs, satisfaction and hedonism of individuals but also to the community in the local area in which they do business.

#### REFERENCES

- [1] Bahena-Álvarez, I.L., Córdón-Pozo, E. & Delgado-Cruz, A. (2019). Social Entrepreneurship in the Conduct of Responsible Innovation: Analysis Cluster in Mexican SMEs, *Sustainability*, 11(13), 3714
- [2] Ivanović, Đukić, M., Petrović-Randelović, M. & Talić, M. (2020). An analysis of factors influencing the development of Social enterprises in the Republic of Serbia, *The European Journal of Applied Economics*, 17(2), 1-18.
- [3] Popkova, E. G. & Bruno S. S. (2021). Dataset Modelling of the Financial Risk Management of Social Entrepreneurship in Emerging Economies, *Risks* 9(12), 211.
- [4] Labaš, D. (2010). Socially responsible business and business success. In *Controlling Between Profit and Sustainable Development* (ed. Osmanagić Bedenik, N.), Zagreb, Croatia: M.E.P. (pp. 263-301).
- [5] Matešić, M., Pavlović, D., Bartoluci, D. (2015). *Socially responsible business*, Libertas. Zagreb.
- [6] Cvitanović, V. (2018). Social entrepreneurship as a direct contribution to economic development. Education for entrepreneurship. *E4E, scientific and professional journal on education for entrepreneurship*, 8, 109-126.
- [7] Tudor, G., Begić, J., Tudor, A. (2018). Good Croatia, socially responsible business - the best of, Croatian contribution to the global sustainable development goals of the UN until 2030. Zagreb, Croatia: M.E.P.
- [8] United Nations International Development Organisation, UNIDO (2007). *Development of a Corporate Social Responsibility Concept for Croatia*, Available at: [https://www.unido.org/sites/default/files/2008-07/RBI\\_newsletter\\_no.11\\_0.pdf](https://www.unido.org/sites/default/files/2008-07/RBI_newsletter_no.11_0.pdf)
- [9] Žužul, M. (2010). Socially responsible business and sustainable development. In *Controlling between profit and sustainable development* (ed. Osmanagić Bedenik, N.) Zagreb, Croatia: M.E.P. d.o.o.
- [10] Ordinance on protective workshops and integrative workshops for the employment of persons with disabilities, Ministry of Labor and the Pension System *Official Gazette*, No. 75/18.

# The Impact of Blockchain Technology on the Accounting Information Systems

Tanja Janačković<sup>1</sup>, Marko Janačković<sup>2</sup>

<sup>1,2</sup>Academy of Vocational Studies Southern Serbia, Department of Higher Business School Leskovac, Leskovac, Serbia

<sup>1</sup>spasictanja7@gmail.com, <sup>2</sup>janackovic.marko@gmail.com

**Abstract**—The aim of the paper is to analyze the impact of blockchain technology on the accounting information system (AIS), i.e. to assess the advantages that can be achieved by applying this technology. Blockchain as Distributed Ledger Technology (DLT), offers new possibilities for recording and creating backup copies of confidential and sensitive AIS data. In order to achieve the goal of the study, a descriptive approach was adopted to research the basics of blockchain technology, as well as an analysis of examples of the introduction of this technology in the practice of the big four accounting companies. As a result, the positive effects of this technology on AIS were reviewed, but possible obstacles and limitations, during the implementation of blockchain technology in accounting, were also pointed out. The effort is to indicate the way in which this technology would affect the change of the accounting industry and profession over time.

**Keywords** – blockchain, technology, accounting information system

## I. INTRODUCTION

The development of information technologies (IT) leads to the computerization of information systems (IS), i.e. the replacement of manual bookkeeping systems with computer systems. The progress of IT influenced the improvement of the functions of the AIS and enabled the efficient collection, processing and retrieval of data [1]. Each stage in the development of RIS has a significant role in promoting the accounting profession. Accounting as IS is focused on providing information to interested users in order to support the financial decision-making process. Accounting as an IS is a set of methods, processes and systems, with the aim of managing

certain rules and policies, in order to transform data into financial information that is important for business decision-making. AIS is also defined as an organized set of components that accumulates, classifies, processes and analyzes financial information and provides it to interested external and internal users in order to make decisions [2]. As in [3] AIS represents “a collection of data and processing procedures that create the necessary information for users” and it is located at the intersection of two disciplines: accounting and IS [4]. The goal of AIS is to process data and transactions, and supply users with information for planning, controlling and performing business activities [5]. The influence and role of AIS in the accounting profession is very important, and it can effectively improve the management and economic benefits of the company.

A distributed ledger is the essence of blockchain technology, and it implies a decentralized distributed database. The distributed blockchain ledger is consistent with the AIS ledger, and can completely replace the existing AIS model. Given the characteristics of decentralization, restrictions on the installation and application of AIS in the past may change. The efficiency of the accounting processing of the distributed ledger can be ensured by the use of blockchain multi-party consensus mechanism technology, in order to set standards and achieve multi-party consensus in accordance with accounting rules. The security and reliability of data is achieved by using the blockchain technology of the smart contract, which limits the collection of data, its processing and the processing of the ledger [6].

The paper will discuss the concept and evolution of blockchain technology, and especially the impact of this technology on AIS, highlighting the positive effects of blockchain on AIS, but also pointing out certain limitations when applying this technology. In addition, examples of the introduction of blockchain technology in the practice of the largest accounting companies, will be pointed out.

## II. BLOCKCHAIN CONCEPT

Blockchain technology was originally developed to support the cryptocurrency Bitcoin and to allow transactions to be carried out without a third party [7, 8]. When performing traditional transactions, money transfers were managed by a third party, a bank or institution. In this way, all transactions were controlled by institutions that were centrally located [9]. The development of blockchain technology has imposed trust based on a decentralized network, as opposed to the previous mechanism of trust in a central authority. With this in mind, legal and commercial transactions take place in a reliable, accountable and distributed environment, without the use of a central server on the blockchain. A blockchain database consists of nodes (computers), where records of transactions are stored together through a network of nodes/computers. Given the unreliable nature of the network, a node verification process is necessary in order to establish a consensus on shared records [10]. Nodes are responsible for adding new blocks to the blockchain, but only after all nodes in the system reach consensus. This means that there is an agreement between all participants regarding the legitimacy of the block, ie. block contains only valid transactions. A new block is shared among all nodes in the system, tracked by each node, but cannot be changed by anyone directly [11]. In blockchain, data (transactions) are divided into blocks, where blocks consist of pieces of digital information. There is a connection of each block with the previous one, and the first block is the genesis block [12]. Blocks represent structures where data that contains values are stored [13].

Blockchain technology becomes a special type of decentralized public record, that is, a public ledger without localization on a central server and is not subject to the monopoly of administration or control. Transactions are immediate, and participants act as equal peer-to-peer (P2P). Once a transaction is undertaken, it cannot be retroactively changed (a block) and is

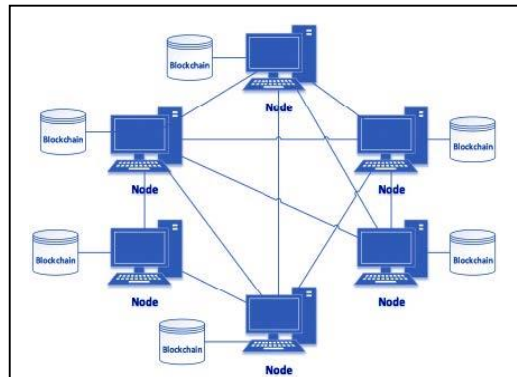
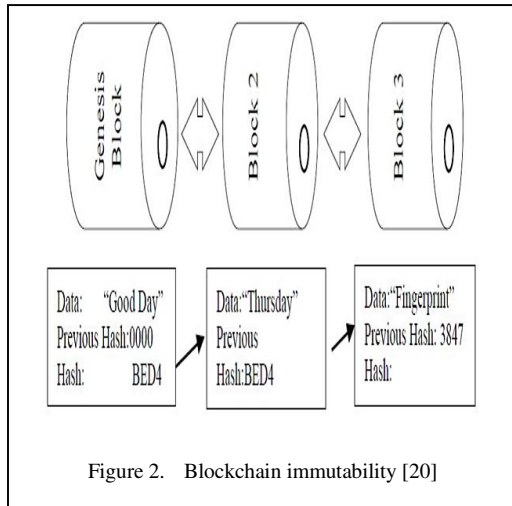

Figure 1. P2P blockchain network [14]

recorded in the chain, in a database that is continuously evolving and thus reflects the chain of transactions. Technically speaking, blockchain implies a distributed database that exists on a P2P network. This network is the backbone of the mechanism, because every node in the system is on the same level as the other nodes. There is no central node that has control and authority. Each node stores a local copy of the blockchain, and if the contract of the node is in agreement with the validation of the transaction, it is considered valid (Fig. 1).

Blockchain is therefore a technology based on a distributed ledger. A distributed ledger consists of “chains” that are interconnected. The content inside a block can be viewed by multiple parties, but at the same time, everything inside the block is protected [15,16]. Each transaction is approved by the participants in the system, and once the information is entered, it cannot be deleted [17]. The ledger is distributed over a network of connected computers, rather than through a single centralized system, and records are kept of all transactions from the first transaction. The blockchain structure is copied and shared by connected computers in the system, and when a transaction occurs, a new transaction is added to the existing ones as a „new block”. As a rule, new transactions are added within the front end of the blockchain, and each time a new block is recognized by a majority of computers, the blockchain is updated to reflect the accepted chain [18]. Blocks are encrypted and anonymous, while transaction headers are public but not owned and cannot be changed by anyone. Headers are publicly available to those who require detailed transaction information [19].

The immutability of the blockchain ensures that in the chain, transactions cannot be changed



into each other. Each block has immutable timestamps that refer to what happened before, so each block references the previous block (Fig.2). If the previous block information is incorrect, a new block cannot be added. Blockchain cannot generate new blocks in an existing chain. Blockchain implies a stronger system than traditional IT infrastructures, and it is more reliable against malware and hacker attacks [18,19].

Technology based on a distributed ledger, i.e. a decentralized system provides significant innovations compared to traditional centralized record keeping. The three main features that distinguish the new blockchain technology include [21]: 1) trustworthiness - multiple copies of historical records in the ledger, which is approved by most computers, 2) transparency, i.e. activity records that are publicly available to all participants in the system and 3) disintermediation - a distributed system eliminates the need for intermediaries, i.e. there is no need for a clearing agency.

### III. THE EVOLUTION OF BLOCKCHAIN TECHNOLOGY

Due to rapid growth and development, blockchain technology has evolved over time. There are three different levels in the development of blockchain technology, as well as generation X, which will be possible with the further progress of this technology [22,23]. As in [15], blockchain is divided into three categories: 1) blockchain 1.0, 2) blockchain 2.0 and 3) blockchain 3.0.

**Blockchain 1.0:** blockchain logic is used only for all cryptocurrencies including Bitcoin. All applications that are related to cryptocurrencies fall into this category. Blockchain 1.0 is therefore a currency and implies the use of cryptocurrency in applications related to cash (currency transfer, remittances, digital payment systems). **Blockchain 2.0** is used by financial services, and smart contracts are introduced. Through smart contracts, credible transactions are executed without the involvement of a third party, which implies various instruments (swaps, bonds, options and derivatives). Blockchain 2.0 is therefore a contract that includes the entire list of blockchain applications in the economy, finance and the market. **Blockchain 3.0** represents the application of blockchain beyond currency, finance and markets to government, health, science, literacy, culture and the arts. In the generation X (blockchain X) variant, the public blockchain is available to everyone, like the Google search engine. This version provides services to all layers of society, and it is a publicly available distributed ledger where rational agents make decisions and connect with other agents for the common good.

### IV. THE IMPACT OF BLOCKCHAIN TECHNOLOGY ON AIS

Considering the research about the use of blockchain technology in accounting, it is possible to categorize the advantages of the real-time blockchain accounting system as follows: 1) transparency and trust, 2) disintermediation, 3) smart contracts, 4) continuous audit [24]. A smart contract is a part of the blockchain, that provides greater security compared to traditional contracts and reduces transaction costs. The feature of a smart contract is that the content cannot be manipulated, and the implementation cannot be prevented. It is a transparent agreement, without conflict, bypassing the mediation services of banks, lawyers, and notaries in its implementation. These contracts can automate each transaction and quickly create records in the blockchain, when the necessary conditions are met [22].

Bearing in mind that accounting is inseparable from the system of economic relations in the state, as well as technical achievements, the blockchain technical infrastructure, which is associated with accounting terminology, can be the driving force for changes in methodological standards of control and accounting activities [25]. This

implies that accounting should strive for the development of methods and procedures in parallel with work in the IT environment, in which blockchain technology is currently leading the way.

Research results of this IT technology highlight several areas where blockchain helps and supports accounting and auditing [14]. These areas include: 1) blockchain from an accounting perspective including: the use of blockchain in designing AIS; improving the efficiency of AIS and increasing the importance of management accounting; and 2) blockchain from an auditing perspective: blockchain creates new opportunities and challenges for continuous auditing and real-time accounting. These processes are based on the development of integrated AIS and real-time AIS, with the aim of creating accessible and cheaper activities. The stability of the system simplifies the exchange of information and prevents fraud.

#### *A. Blockchain from an Accounting Perspective*

Blockchain from an accounting perspective implies the following changes [24], relating to: the use of blockchain in designing AIS and increasing the efficiency of AIS.

The use of blockchain in designing AIS includes the following: 1) adopting the zero-knowledge proof method, it is possible to create a blockchain-based RIS as well as develop a model that would illustrate the role of this system in real-time accounting, continuous auditing and monitoring, and detection of financial fraud [26]; 2) a free open ledger is provided in order to register the ownership of a wide range of assets, i.e. the state is investigating the use of blockchain in public records such as birth certificates, driver's licenses, university degrees; 3) represents an alternative technique for bookkeeping (e.g. in the processes of mergers and acquisitions, a common understanding among key figures allows more time to be directed to the areas of management and consulting and makes the system faster [27]; 4) smart contracts can be embedded or replaced with operational and/or administrative functions that affect internal and external reporting - in this way, performance targets and budgets can be translated to monitor smart performance contracts against actual results. New blockchain performance management systems can be linked to performance contracts, performance appraisals and performance bonuses. In addition, a segment of non-financial reporting such as

environmental reporting can be encouraged; 5) it is possible to represent intangible assets (intellectual property rights) as digital property contracts, which can be designed to automatically route assets; 6) it is possible to report on financial capital on the blockchain, whereby ownership can be easily transferred in a similar way to the exchange of cryptocurrencies; 7) corporate loans can be viewed as "smart loan contracts" - debt obligations can be simply transferred, and the due date can be automatically tracked.

The use of blockchain in increasing the efficiency of AIS includes the following: 1) integrating blockchain technology and accounting has contributed to the elimination of unnecessary manual effort, speeding up payment settlement and avoiding fraud in financial reporting. In addition, the way in which corporations are managed and operated has been radically changed [26]; 2) the time difference between the published financial reports of the company has been eliminated - time delays will be completely eliminated by the use of a real-time accounting system, which enables real-time monitoring of payments by the general public or key stakeholders [28]; 3) it provides the possibility of quick application of accounting processes [25]; 4) blockchain increases the reliability of payment and resource accounting and it is a mechanism for keeping detailed accounts; 5) the use of blockchain provides accountants with clarifications on the ownership of assets, on the nature of liabilities and can significantly improve results. Blockchain can also advance the accounting profession by reducing the cost of tracking, by providing security in terms of identity, as well as the origin of assets in the past [27]; 6) good blockchain applications are focused on cost and time savings, by removing central peripherals from the system, thus increasing the safety and security of the consensus system.

#### *B. Effects of Blockchain Application in AIS*

Some of the possible effects of blockchain application in AIS based on the use of electronic funds include: impact on accounting activity, impact on AIS design, the possibility of reducing the costs of protecting the integrity of information and increasing the rate of settled transactions, impact on the transparency of management decision-making, challenges of blockchain application in accounting [14].

The transition to a financial system based on blockchain technology will provide a number of incentives for the accounting profession. Given that this is a new approach, accounting professionals will be able to lead and influence the implementation and application of this approach in the future. In order to integrate the technology as part of the financial system, it is necessary to develop, standardize and strengthen the blockchain, which takes time. A big challenge is setting standards for blockchain reporting, which requires leading accounting firms to offer their skills and knowledge in this domain. Accountants also play a significant role, bearing in mind the need to assess the benefits and costs of the new system.

In terms of impact on AIS, the technology is reliable, distributed and available as an open system with minimal usage costs [29]. The application of blockchain for accounting purposes is a new challenge for the accounting profession, as it can facilitate compliance with regulatory requirements in order to improve the current accounting system. Blockchain often refers to different payment systems as well as specific accounting standards. This technology works as a shared, neutral database that keeps records of transactions. In addition, the system allows managers and auditors to compile individual transactions and produce financial statements at their discretion [30]. Real-time accounting procedures are software solutions that enable currency transfers, derivatives and other electronic transfers between two or more entities, while storing transaction data in encrypted blocks. In order to add value to the business as well as for stakeholders, it is important that the blockchain accounting system supports the following real-time features: 1) transparency - availability of transactions in real time (e.g. bitcoin), 2) stability - i.e. not assigning programming capacity for modifying elements of transactions and 3) accessibility - availability of data to a wide range of users.

In terms of reducing information protection costs, blockchain technology should be integrated into accounting procedures. The basic characteristics are [14]: 1) high level of use - preserving the accuracy of information in order to fully monitor audit reports and ensure a fully automated audit, 2) continuity - each client has its own version of the registry, where reality is universally accepted, while previous transactions cannot be changed without the approval of the majority, the entire registry is kept by all parties

and can be verified and confirmed in real time, 3) programmability – certain strings used by the blockchain allow the storage of ledger entries and the creation of journal entries that are automatically executed under the name of smart contracts.

Considering the transparency of decision-making, companies that use blockchain are more transparent, because blockchain allows identifying a traceable database and allows the creation of a full time frame for all management activities and decisions. So, for example, *BoardRoom* is a pioneering example of blockchain software managing, created by *Ethereum*.

The application of blockchain in the field of accounting bring advantages based on the use of this technology in AIS, but also certain obstacles may arise. Three limitations have been observed that can hinder the application of blockchain in accounting [31]: 1) data privacy - the effort to preserve the confidentiality of data is justified, bearing in mind that lists of customers and suppliers, unit costs and tactical transactions in the register can become profitable trade secrets. In addition, blockchain authentication techniques are not suitable for payment verification from an accounting point of view, since these technologies do not recognize the reality and peculiarities of transactions. With this in mind, accounting professionals know that checks are necessary to prevent fraud and eliminate errors, which will not be eliminated by the introduction of blockchain.

## V. APPLICATION OF BLOCKCHAIN IN THE PRACTICE OF ACCOUNTING COMPANIES

Observing the application of blockchain in large accounting companies belonging to the group of big four (Deloitte, Ernst Young, KPMG, and PwC) each of them found a definite interest in the application of blockchain [32].

Deloitte was the first company to enter the crypto space among these companies, announcing the first blockchain lab in Dublin, Ireland in 2016. In collaboration with the Bank of Ireland, a joint proof of concept based on a blockchain trial was carried out. Three of Ireland's largest banks use Deloitte's blockchain to verify the credentials of their employees [33]. In addition, in 2014, the business blockchain *Rubix*, in Toronto, was launched, which offers consulting services and creates decentralized



applications based on the blockchain platform for clients from various industries.

Ernst Young in Switzerland is the first of the “big four” accounting firms to accept bitcoin for accounting and auditing services. In 2018, EY introduced the *EY Blockchain Analyzer*, which according to EY's press release “is a suite of blockchain audit technologies that improve the ability to perform an in-depth review of cryptocurrency business transactions” [34]. EY is continuously developing blockchain-based solutions such as *Nightfall*, *Dye Pack*, *Smart Contract* and *Token Testing*.

In 2016, KPMG launched a *Digital Ledger Services Program* to help financial services companies explore blockchain. Digital ledger services allow financial institutions to realize the potential of blockchain cloud capabilities, such as faster and more secure transactions, reduced costs, and automated and simplified back-office operations. In addition, the company became a partner with Microsoft Corp. for the launch of the “blockchain Nodes” initiative, in order to create and identify new applications and use cases of blockchain technology.

PwC is the second largest accounting firm in the world which has accepted bitcoin payments for its services [35]. The company supports a variety of blockchain projects and has introduced blockchain auditing services to empower people to use this technology. The audit service requires independent validation, and the decentralized digital ledger can also be used for online identity verification, supply chain management and audit financial transactions. This company views blockchain as a software that will structurally modify the common traditional practices between customers, competitors and suppliers in the next generation of business. In addition, PwC believes that the pace of development of these solutions will not be fast, given the regulatory uncertainty [36].

## VI. CONCLUSION

Blockchain technology has enabled new business models, business and production processes, where ownership is accessed and shared, as well as innovative organizational forms and real-time accounting systems. In this way, blockchain technology offers advantages for accounting practitioners and users of information from various aspects. Blockchain technology in accounting provides numerous benefits such as simplifying operations,

minimizing the risk of fraud and corruption in accounting transactions, bearing in mind that a block added to the chain cannot be changed unilaterally, without the consent of all parties in the transaction. In addition, the efficiency and productivity of the audit increases, and simplifies business, given that the relevant transactions are open to the supervision of all authorized parties inside and outside the organization.

Possible effects of applying blockchain in AIS include: impact on accounting activity, impact on AIS design, possibility of reducing the costs of protecting the integrity of information and increasing the rate of settled transactions, as well as impact on the transparency of management decision-making. On the other hand, there are challenges and limitations regarding the application of blockchain in accounting. They relate to data privacy, the ability of companies to retroactively deal with their own blockchains, and the limited ability of blockchains to verify transactions. The application of blockchain for accounting purposes is a new challenge for the accounting profession, as it can facilitate compliance with regulatory requirements in order to improve the current accounting system. In order to add value to the business as well as for stakeholders, it is important that the blockchain accounting system supports real-time features related to transparency, stability and accessibility, i.e. data availability to a wide range of users. The transition to a financial system based on blockchain technology will provide a number of incentives for the accounting profession. A big challenge is setting standards for blockchain reporting, which requires leading accounting firms to offer their skills and knowledge in this domain. The role of the accountant is also significant, bearing in mind the need to assess the benefits and costs of the new system.

## REFERENCES

- [1] Janačković, T. (2016). *Razvoj informacionog sistema za finansijsko izveštavanje baziranog na veb tehnologiji*. Doktorska disertacija. Univerzitet u Nišu, Ekonomski fakultet, Niš.
- [2] Moscovice, S.A., Simkin, M., & Bagranoff, N. (1997). *Core Concepts of Accounting Information Systems* (5th ed.). Wiley.
- [3] Bagranoff, N., Simkin, M., & Norman, C. (2010). *Core Concepts of Accounting Information Systems*. John Wiley & Sons, Inc.
- [4] Bawaneh, S. (2014). Information Security for Organizations and Accounting Information Systems: A Jordan Banking Sector Case. *International Review of Management and Business Research*, 3(2), 1174-1188.

- [5] Romney, M., Steinbart, P., & Cushing, B. (1997). *Accounting Information System* (7th ed.). Addison-Wesley.
- [6] Su X., Xiao, Y., & Liu S. (2021). Analysis on the Impact of Blockchain Technology on the Accounting Profession. In *7th International Conference on Economy, Management, Law and Education (EMLE 2021)* (pp. 10-14). Atlantis Press.
- [7] Alkan, B. Ş. (2021). Real-Time Blockchain Accounting System As A New Paradigm. *The Journal of Accounting and Finance*, Special Issue, 41-58.
- [8] Biswas, K., & Muthukkumarasamy, V. (2016). Securing Smart Cities Using Blockchain Technology. IEEE 18th International Conference on High Performance Computing and Communications; IEEE 14th International Conference on Smart City; IEEE 2nd International Conference on Data Science and Systems, (pp.1392-1393).
- [9] Yli-Huomo J, Ko D, Choi S, Park S, & Smolander, K. (2016). Where Is Current Research on Blockchain Technology? - A Systematic Review. *PLoS ONE* 11(10), e0163477.
- [10] Brown, R. G. (2016). *On Distributed Databases and Distributed Ledgers*. Thoughts on the Future of Finance. <https://gndal.me/2016/11/08/on-distributed-databases-and-distributed-ledgers/>
- [11] Inghirami, I. E. (2019). Accounting Information Systems: The Scope of Blockchain Accounting. *13th Mediterranean Conference on Information Systems and 16th Conference of the Italian Chapter of AIS*.
- [12] Zheng, Z., Xie, S., Dai, H. N., Chen, X., & Wang, H. (2018). Blockchain challenges and opportunities: A survey. *International Journal of Web and Grid Services*, 14(4), 352-375.
- [13] Reiff, N. (2020). *Blockchain Explained*. Available at: <https://www.investopedia.com/terms/b/blockchain.asp>
- [14] Olaru (Colbea) E. A. (2021). The Impact of Blockchain on the Accounting Profession. *CECCAR Business Review*, 4, 63-72
- [15] Güdelci, E. N. (2022). New era in blockchain technology and better accounting information. *Journal of Accounting and Taxation Studies*, 15 (2), 437-461.
- [16] Mc Comb II, J.M., & Smalt, S. W. (2018). The rise of blockchain technology and its potential for improving the quality of accounting information. *Journal of Finance and Accountancy*, 23, 1-7.
- [17] Crosby, M., Pattanayak, P., Verma, S., & Kalyanaraman, V. (2016). Blockchain technology: Beyond bitcoin. *Applied Innovation*, (2), 6-10.
- [18] George, R. P., Peterson, B. L., Yaros, O., Beam, D. L., Dibbell, J. M., & Moore, R. C. (2019). Blockchain for business. *Journal of Investment Compliance*, 20(1), 17-21.
- [19] Hughes, A., Park, A., Kietzmann, J., & Archer-Brown, C. (2019). Beyond bitcoin: What blockchain and distributed ledger technologies mean for firms. *Business Horizons*, 62(3), 273-281.
- [20] Kasthala, V. (2019). *Blockchain key characteristics and the conditions to use it as a solution*. Medium. Available at: <https://medium.com/swlh/blockchain-characteristics-and-its-suitability-as-atechnical-solution-bd65fc2c1ad1>
- [21] Deloitte. (2017). *The future of blockchain: Applications and implications of distributed ledger technology*. Chartered Accountants Australia and New Zealand. <https://www2.deloitte.com/content/dam/>
- [22] Hartoyo, A., Sukoharsono, E. G., & Prihatiningtias, Y. W. (2021). Analysing the Potential of Blockchain for the Accounting Field in Indonesia. *Jurnal Akuntansi dan Keuangan*, 23(2), 51-61.
- [23] Fanning, K., & Centers, D. P. (2016). Blockchain and its coming impact on financial services. *Journal of Corporate Accounting & Finance*, 27(5), 53-57.
- [24] ALSaqa, Z. H., Hussein, A. I., & Mahmood, S. M. (2019). The Impact of Blockchain on Accounting Information Systems. *Journal of Information Technology Management*, 11(3), 62-80.
- [25] Shyshkova, N. (2018). Prospects for the Implementation of Blockchain in Accounting. *Accounting and Finance*, 2, 61-68.
- [26] Wang, Y., & Kogan, A. (2018). Designing confidentiality-preserving Blockchain-based transaction processing systems. *International Journal of Accounting Information Systems*, 30, 1-18.
- [27] ICAEW (2017). *Blockchain and the future of accountancy*. Information Technology Faculty, London. Available at: [www.icaew.com](http://www.icaew.com).
- [28] Potekhina, A., & Riumkin, I. (2017). *Blockchain – A new accounting paradigm: Implications for credit risk management*. Master degree thesis, Umeå School of Business and Economics.
- [29] Deloitte. (2016). Blockchain Technology. *A Game-Changer In Accounting?* Available at: [https://www2.deloitte.com/content/dam/Deloitte/de/Documents/Innovation/Blockchain\\_A%20game-changer%20in%20accounting.pdf](https://www2.deloitte.com/content/dam/Deloitte/de/Documents/Innovation/Blockchain_A%20game-changer%20in%20accounting.pdf).
- [30] Wang, Y., & Kogan, A. (2017). *Designing privacy-preserving Blockchain-based accounting information systems*. [https://papers.ssrn.com/sol3/papers.cfm?abstract\\_id=2978281](https://papers.ssrn.com/sol3/papers.cfm?abstract_id=2978281)
- [31] Coyne, J.G., & McMickle, P.L. (2017). Can Blockchains Serve an Accounting Purpose?. *Journal of Emerging Technologies in Accounting*, 14(2), 101-111.
- [32] Baba, A. I., Neupane, S., Wu, F., & Yaroh, F. F. (2021). Blockchain in accounting: challenges and future prospects. *Int. J. Blockchains and Cryptocurrencies*, 2(1), 44-67.
- [33] O'Neal, S. (2019). *Big Four and Blockchain: Are Auditing Giants Adopting Yet?* Available at: <https://cointelegraph.com/news/big-four-and-blockchain-are-auditing-giantsadopting-yet>.
- [34] EY (2018). *EY announces blockchain audit technology?*. EY. Available at: [https://www.ey.com/en\\_no/news/2018/04/ey-announces-blockchain-audit-technology](https://www.ey.com/en_no/news/2018/04/ey-announces-blockchain-audit-technology).
- [35] Das, S. (2017). *Big 4 Accounting Giant PwC Accepts its First Bitcoin Payment*. Available at: <https://www.ccn.com/big-4-accounting-giant-pwc-accepts-first-bit-coin-payment/>.
- [36] PwC. (2018). *Blockchain is here. What's your next move?*. <https://www.pwc.com/blockchainsurvey>.



# Family Business Management in the Knowledge Era

Sandra Stojadinović Jovanović<sup>1</sup>, Bojan Krstić<sup>2</sup>, Violeta Domanović<sup>3</sup>

<sup>1</sup>Western Serbia Academy of Applied Studies, Užice, Serbia

<sup>2</sup>University of Niš, Faculty of Economics, Niš, Serbia

<sup>3</sup>University of Kragujevac, Faculty of Economics, Kragujevac, Serbia

<sup>1</sup>sandrassj28@gmail.com, <sup>2</sup>bojan.krstic@eknfak.ni.ac.rs, <sup>3</sup>vterzic@kg.ac.rs

**Abstract**—Family business represents the oldest and the most common form of economic organizations in the world. In many countries, family firms represent a huge percentage of the total number of firms. Family businesses face the same challenges as other businesses. But, in addition, they have to solve many issues that are specific to them. Management of these companies is often much more complex than management of companies where family relationships do not influence decision making. Because in these companies, not only work is managed, but also family. The aim of the paper is to point out the features of family business and its management and to snapshot this business in the contemporary knowledge economy.

**Keywords** - family business, management, knowledge

## I. INTRODUCTION

There are many different definitions of family businesses. A narrow definition would mean only a company that is wholly owned by one family and managed by its founders and/or their family members. A somewhat broader definition would also include companies in which the founder's family has a controlling stake and a leading role in top management. The broadest definition of family firms also includes firms in which the founder's family is only one of the minority owners, but regardless, the family continues to have a significant influence on the company and this influence is not proportional to the ownership share of the family in the company [1]. Despite numerous definitions, the term family business most often means a company in which the majority of votes are in the hands of the family that controls the

company, including the founder(s) who intend to pass the company on to their descendants [1].

Family businesses are those in which two or more members of the same family control, are directly involved in, and own a majority of the business. What makes them different from nonfamily businesses are two critical factors: (1) the complex interrelationships of family members interacting with one another and interacting with the business, and (2) the intricate succession planning needed [2].

Family businesses are of great importance in the economies of a number of countries. They represent the oldest and the most common form of economic organizations in the world. In many countries, family firms represent a huge percentage of the total number of firms and provide a key contribution to economic growth and employment.

In Switzerland, 88% of all companies are family business. This rate in the rest of Europe varies between 70% and 80%, while in the USA it is 90%. [3] Family companies make up more than 60% of all companies in Europe. Family businesses account for 80% of all businesses in the United States and are responsible for nearly 50% of the U.S. gross domestic product (GDP). In Great Britain, 75% of registered companies are family businesses, while in India, the Far and Middle East, that number reaches 95%. In Latin America, as much as 60% of the gross social product is generated by family firms [1].

There are family firms among small and medium enterprises, but also among large, global companies. Walmart, Volkswagen, Berkshire Hathaway, Roche are just some of the

most famous and richest family businesses in the world [4]. Some of the well-known family businesses include Fiat Group and Benetton in Italy, L'Oreal, LVMH and Michelin in France, Samsung, Hyundai and LG Group in South Korea, BMW and Siemens in Germany, C&A, Heineken and Philips in the Netherlands. The oldest family company is the Takenaka Corporation from Japan, active in the real estate sector, which has been operating since 1610 [3]. Walmart is the world's largest retailer. This family business is considered one of the richest in the world, and since 1945, when Sam Walton opened the first store, three generations have changed.

## II. FAMILY BUSINESS MANAGEMENT FEATURES

Family businesses face the same challenges as other businesses. But, in addition, they have to solve many issues that are specific to them. Management of these companies is often much more complex than management of companies where family relationships do not influence decision-making. Because in these companies, not only work is managed, but also family.

In the case of family businesses, the interests of family, business and ownership overlap. The founder is also the director and the head of the family who feeds the family. The system of three circles, which, at the beginning of the formation of a family business, overlap, is very centralized, because one person makes all important decisions. As, over time, the business develops, the system becomes more complex, the circles are separated, and the interests of all three fields still remain and become more complicated. These are the interests that have: (1) family, (2) business, and (3) property [5].

Family businesses have their advantages, which allow them to ensure their survival and growth, but also disadvantages, which can determine their failure. The key positive aspects that characterize a family business are: trust among family members, loyalty to the family, devotion, knowledge, far-reaching thinking and close communication. The key positive aspects that characterize a family business are: distrust of employees who are not family members in incompetent employees who are family members, lack of loyalty to the company, benefits, lack of knowledge, demands for quick satisfaction, failure in communication [6].

Family businesses, in general, have a number of advantages. They are characterized by their commitment and desire to preserve the company for future generations, which is why they have a long-term focus on survival and growth, rather than quarterly results. Many families are therefore ready to work harder, to sacrifice, and to reinvest profits in the company in order to enable it to grow. In addition, as the family runs the firm, the interests of the majority owner and top managers are aligned. Another advantage is the continuity of knowledge. Families make it a priority to transfer their accumulated knowledge, experience and skills to the next generation. Many family members are involved in the business from an early age. This ensures commitment, but also the necessary transfer of knowledge. The third important advantage of family businesses is the reliability and importance that the family attaches to the company's reputation. As the name and reputation of a family business is associated with its products and services, it invests efforts in raising the quality of its production and maintaining good relations with its business partners and clients. Additionally, these companies tend to focus on core competencies, but are also more flexible in their business approaches. As a rule, family businesses have a clear and recognizable identity. The human dimension is an important aspect in family businesses, so employees are often more loyal, you know who works and for whom, so it is a common phenomenon that generations of employees work for generations of owners.

At the same time, family businesses are burdened by significant disadvantages, which make them difficult to sustain in the long term. In general, there is a specific generational dimension in family businesses that is not present in non-family-owned firms. So the first disadvantage of family businesses is complexity, because family relationships are added to business relationships. Another disadvantage of family businesses is that informality is resorted to, which occurs due to little interest in establishing clearly defined business practices and procedures. This further leads to ambiguities, which increase as the company grows. The third shortcoming of these companies is related to not paying enough attention to key strategic areas, such as family business succession planning, hiring qualified managers, etc. Postponing or ignoring such

important strategic decisions could affect the survival of the family business. Fourth, in the first and sometimes second generation, the company is managed by the founder and family members. However, at this stage it is important to attract and retain quality professional management staff. Over time, as they grow, family businesses must, in addition to successors, include professional managers in the business, i.e., appoint both successors and professional managers in the right place.

In family businesses, the issue of succession is very important in the long term. On average, four generations from the same family lead these businesses. The success of a family business depends on the successful transfer to the next generations of the family.

In order to understand the succession of a family business to the next generation, it is important to understand the difference between the management of the company's capital and the management of the company. Owners manage the capital and managers run the business. Founders are both owners and managers. That is why inheritance differs between ownership inheritance, i.e. management of company capital, and inheritance in business management of the company. Practically, this means that four, most common, cases are possible: a) the first, that children inherit property and be managers; b) others, to inherit property, but to do some completely different things in life; c) the third (which is less practical and more theoretical) not to become owners, but to be managers; and d) the fourth (slightly less theoretical and more practical than the previous one) not to inherit the ownership of the company (they will inherit something else) and not to manage the company [7].

Out of 100 family companies that survive through the first generation, only about 30 survive to the end of the second generation. The largest number of family firms has a very short life span after the foundation phase and almost 95% of family firms do not survive the third generation of ownership. About 2/3 to 3/4 of family businesses fail or are sold by the founders while still in their ownership.

The overlapping of two aspects, family and business, makes the management of a family business complex. When family roles and business interests collide, significant conflicts

can arise. Anticipating these challenges and preparing for them can really pay off.

The many possible family roles and relationships add to the complexity of family business management. They include the following roles and relationships: a) founder (mom or dad); b) husband-wife teams; c) sons and daughters; d) cooperation, as well as rivalry, of brothers and sisters; e) in-laws in business and outside it; f) the entrepreneur's spouse [8].

### III. FAMILY BUSINESS IN THE KNOWLEDGE ERA

Today, two economies exist in parallel, the industrial economy and the knowledge economy, both at the aggregate, national and broader level, as well as within individual sectors, i.e. companies and organizations. [9] We witness a rapid transition from an industrial society into a knowledge society. The knowledge society is based on the growing importance of knowledge as the so-called fourth production factor [10]. The industrial economy and the knowledge economy are not mutually exclusive, but they are very different. In search of answers to these differences, a knowledge-based view of the firm was developed as a set of ideas about the existence and role of the firm in which the emphasis is on the role of knowledge. This approach is based on the following assumptions: 1) knowledge is the most important production resource; b) different forms of knowledge vary in the degree of transferability: explicit knowledge can be easily transferred between individuals and organizations, while implicit knowledge is not easy to transfer, because it is highly personalized and manifests itself through application; c) knowledge is the subject of economies of scale and scope; d) knowledge is created by individuals, and in order to be effective in creating and preserving knowledge, they must specialize; e) production of goods and services usually requires the application of different types of knowledge [11].

Different kind of knowledge flows can be identified in the family business. The largest family business and retailer in the world [12], Walmart, is good example of various kinds of knowledge flows in the family business. This giant company has 2.3 million employees, including nearly 1.6 million in the U.S. alone, making it the largest private employer in the world. It operates approximately 10,500 stores in 24 different countries, achieving total retail

revenues of \$538.15 billions. The first store opened in 1962 was based on the principle of low prices and the company quickly expanded. Within less than a decade, Walmart reached sales of 78 million USD, had gone public and opened its first distribution centre. In 1980, Walmart's sales exceeded 1 billion USD. Walmart took its internationalization in the 1990s. Many internationalization steps followed, using joint ventures, greenfield investment and acquisitions [13].

Different kind of knowledge flows occurs in this the largest family business including knowledge flows between foreign subsidiaries and the parent company and knowledge flows among subsidiaries. Many Walmart subsidiaries around the world rely on the knowledge and competence of their parent company in logistics, information technology and various strategies and implement these in their host countries. Therefore they can be categorized as knowledge users. Some subsidiaries accumulated a high level of knowledge before their acquisition by Walmart and they can be categorized as a knowledge independent or local innovator. There is also a subsidiary that exchange knowledge in both directions and can be categorized as a knowledge networker. It has a high level of unique knowledge but it also learns from the other Walmart subsidiaries and the parent company. Finally transfer of a very high level manager from subsidiary to a parent company or to other subsidiary can be categorized as knowledge transfer [14].

With increased labor mobility and information transfer, knowledge and expertise can be instantly transferred anywhere in the world. In the knowledge era, people are the company's most valuable and useful resource. They are the storehouse of knowledge that the company has at its disposal, the potential and the basis of competitive advantage.

Family businesses must carefully observe people, family members, who want a managerial position in the company and determine whether they are up to the task. Complex relationships in family firms require the supervision of competent and professional management, either from within or outside the family.

Good management is essential for the success of any business, and a family business is no exception. Significant deviations, due to family reasons, from what would be considered

good management practice only lead to the weakening of the company.

There are a number of family business best practices suggested by family business experts and practitioners. Every family and every family business is different, so what is actually best will depend on the individual situation. However, best practices have helped many family businesses to design effective management systems and they include, among other things: promoting learning to stimulate new thinking and fresh strategic insights [8].

Knowledge era requires knowledge management – doing whatever it takes to get the most out of knowledge as a resource [15] including a systematic effort to discover, organize and make available the company's intellectual capital and to support a culture of continuous learning and information sharing, so that activities are based on what is already known [16] as well as developing a culture of learning in which employees systematically acquire and share knowledge with others in order for the organization to achieve the best possible performance [17].

Effective knowledge management is essential for achieving a competitive business advantage. In the contemporary business environment, the business value is based on the intellectual property. Hence, the knowledge is a power, which makes such changes and improvements that lead to the long-term sustainable growth and development. Knowledge management is focused on exploiting the intellectual property in order to improve the efficiency, generate new value and increase the competitiveness [18]. A family business is a business, a competitive business. Following these and other good management practices will help the business thrive and allow the family to function as a family. Neglecting them will pose a threat to work and put pressure on family relationships.

#### IV. CONCLUSION

Family businesses represent the oldest and the most common form of economic organizations in the world. There are family firms among small and medium enterprises, but also among large, global companies. Family businesses have their advantages, which allow them to ensure their survival and growth, but also disadvantages, which can determine their failure. In contemporary global economy family

businesses operate in conditions of rapid transition from an industrial society into a knowledge society. The knowledge society is based on the growing importance of knowledge as the fourth production factor. Different kind of knowledge flows occurs in family businesses including knowledge flows between foreign subsidiaries and the parent company and knowledge flows among subsidiaries. With increased labor mobility and information transfer, knowledge can be instantly transferred anywhere in the world. Knowledge era requires knowledge management – doing whatever it takes to get the most out of knowledge as a resource. Effective knowledge management is essential for achieving a competitive business advantage. In the contemporary business environment, the knowledge is a power, which makes changes and improvements that lead to the long-term sustainable growth and development.

#### REFERENCES

- [1] Đulić, K. (2017). *Corporate governance in family firms [Корпоративно управљање у породичним фирмама]*. Available at: <https://www.porodicnefirm e.com/2017/02/12/korporativno-upravljanje-u-porodic nim-firmama/>
- [2] Hatten, T. S. (2012). *Small business management: entrepreneurship and beyond*. South-Western Cengage Learning.
- [3] BIZLife (2015). *These are the largest family companies in the world [Ово су највеће породичне компаније у свету]*. Available at: <https://bizlife.rs/77812-ovo-su-najvece-porodicne-kompanije-u-svetu/>.
- [4] *The world is ruled by family firms: Walmart is the largest, Takenaka is the oldest [Светом владају породичне фирме: Волмарт највећа, Такенака најстарија]*. (2015). Available at: <https://informer.rs/planeta/vesti/210883/svetom-vladaju-porodicne-firme -volmart-najveca-takenaka-najstarija>.
- [5] Шварц, М. (2016). *One head three hats [Једна глава три шешира]*. *Adizes Southeast Europe*, Available at: <https://www.asee.biz/jedna-glava-tri-sesira/>.
- [6] Longenecker, J. G., Petty, J. W., Palich, L. E. & Hoy, F. (2014). *Small business management: launching & growing entrepreneurial ventures*. Cengage Learning.
- [7] *Development of family companies [Развој породичних компанија]*. *Adizes Southeast Europe*, Available at: <https://www.asee.biz/razvoj-porodicnih-kompanija/>.
- [8] Longenecker, J. G., Moore, C. W., Petty, J. W. & Palich, L. E. (2008). *Small business management: launching & growing entrepreneurial ventures*. Thomson South-Western.
- [9] Babić, V. (2012). *Introduction to management [Uvod u menadžment]*. Ekonomski fakultet, Univerzitet u Kragujevcu.
- [10] Baets, W. (Ed.). (2005). *Knowledge management and management learning: extending the horizons of knowledge-based management*. Springer.
- [11] Grant, R. M. (2003). The knowledge-based view of the firm. In Faulkner, D. O. & Campbell, A. (Eds.) *The Oxford Handbook of Strategy*. Vol. I, Oxford University Press.
- [12] National Retail Federation. (2022). Available at: <https://nrf.com/resources/top-retailers/top-50-global-retailers/top-50-global-retailers-2022>.
- [13] Walmart (2022). Available at: <https://corporate.walmart.com/about>.
- [14] Morschett, D., Schramm-Klein, H. & Zentes, J. (2015). *Strategic international management: text and cases*. Springer Gabler.
- [15] Becerra-Fernandez, I., Gonzales, A. & Sabherwal, R. (2004). *Knowledge management – challenges, solutions and technologies*. Pearson Prentice Hall.
- [16] Daft, L. R. (2008). *The leadership experience*. Thomson South-Western.
- [17] Robbins, S. P. & Coulter, M. (2007). *Management*. Pearson Prentice-Hill.
- [18] Domanović, V. (2018). *Knowledge management and business success of companies [Upravljanje znanjem i poslovni uspeh preduzeća]*. In Ivanović, V., Zlatanović, D., Nikolić, J., Kalinić, Z., Jovković, B. & Janković, N. (Eds.). *Implications of the knowledge economy for development processes in the Republic of Serbia [Implikacije ekonomije znanja za razvojne procese u Republici Srbiji]*. (pp. 393-408). Ekonomski fakultet, Univerzitet u Kragujevcu.





# Digital Transformation in the Field of Education using an Innovative Solution

Aleksandra Tašković<sup>1</sup>, Angela Fajsi<sup>2</sup>, Slobodan Morača<sup>3</sup>

<sup>1,2,3</sup>University of Novi Sad, Faculty of Technical Sciences, Novi Sad, Serbia

<sup>1</sup>aleksandra.taskovic98@gmail.com, <sup>2</sup>angela.fajsi@uns.ac.rs, <sup>3</sup>moraca@uns.ac.rs

**Abstract**—As users are the ones who have the most impact on the market and as today's organization is reorienting its business towards them, digital transformation is one of the solutions that can improve and advance the way organizations deliver their value to end users. The research work aims to show the importance of digital transformation in the field of education and to present conceptual solutions, through a business proposal, that would improve the way of working at faculties, increase and maintain student satisfaction and develop interest on the part of them.

**Keywords** - digital transformation, innovation, education, application.

## I. INTRODUCTION

Digital transformation represents the process of integrating digital technologies in all areas of the organisation, in order to create new or modifies existing processes, meet all business and market requirements and improve the end-user experience. By digitizing the process in the field of education, educational institutions have a chance to better deliver their services, which would improve the final experience of students, as well as achieve the ability to attract and retain students at their faculties. Considering the current environment and the situation in the world, faculty institutions should allow students greater flexibility and provide choices in the way they study. One of the main examples of digital transformation occurred during the Covid-19 pandemic. Educational institutions were forced to find a solution in which human contact would be avoided, for classes to take place without interruption. In that period, technology played a key role in achieving the given goal, which

showed the potential of digital transformation and indicated the benefits it can contribute to educational institutions. Further work will present an innovative solution in the form of an application, which would increase flexibility in faculty institutions, improve the way of monitoring and acquiring practical and theoretical knowledge, and increase students' interest and engagement.

## II. THE TERM OF DIGITAL TRANSFORMATION

Digital transformation uses technology to create new value, new services, innovation, and the ability to quickly adapt to changing circumstances. What characterizes digital transformation are innovation and creativity in finding solutions, the use of digital technologies to create solutions, leadership and perseverance in managing changes, as well as the risks that these changes can contribute. Any digital transformation, in order to be successful, must first of all be initiated by a problem statement, a clear opportunity, or a strategic goal of the organization. It starts and ends with customers. This means that in the modern way of management, the customer/user/client is the first and starting point that is reviewed and analyzed to improve the experience and overall satisfaction with the service/product. The main goals as well as the drivers of digital transformation are in optimizing the user experience, starting innovation, achieving operational flexibility, developing new revenue streams and value systems based on information, which leads to the transformation of business models and new forms of digital processes. However, in addition to the external view, the

transformation itself must also take into account the internal environment of the organization, which implies analysis at the level of legacy systems and interruptions in processes, as well as the IT infrastructure itself and human expertise in the use of digital solutions. As human is the one who has the main role in the final judgment of the success of the innovation/change, the psychological factor of the same must also be taken into account, i.e. it is necessary to assess the level of acceptance when introducing the change. By understanding and identifying these factors, innovators are provided with a view of the market and the target group to which the innovation would be marketed, to reduce barriers when introducing new products to the industrial market and accelerate the acceptance of the change.

### III. THE PSYCHOLOGY OF CHANGE

Innovation continues to transform the global marketplace and the modern workplace, offering potential solutions to the challenges that organizations face. As already mentioned, the main example of mass digital transformation followed during the period of the COVID-19 pandemic. People were forced to quickly adapt and accept the change in the way of work and business. However, the question arises as to how people would react to innovation and change if they had a choice of acceptance and what would influence their decision.

Many innovators work tirelessly to develop innovations in a rapidly changing and competitive market, but no matter how good those innovations are for society or industry, their success depends solely on human acceptance. Factors that influence innovation diffusion and subsequent adoption can be socioeconomic, cultural, technological, as well as legal factors. Individual determinants such as psychological variables and demographics may also play a role. Barriers faced by the adopters of innovations are based on the very background of the innovation, on the values that the person shares, on the lifestyle, perception, culture [1]. As a consequence of those barriers, innovation is characterized as a threat that can change a certain routine in life. One type of barrier may refer to socio-culturally accepted norms of behavior that the consumer segment considers "correct and appropriate". This type of barrier explains traditional and moral values that reject everything new and everything that does not support the traditional form, so it's considered

psychologically threatening. For example, marketing clothing such as shorts and T-shirts in the Middle East would be unsuccessful considering the values that the region promotes. Another type of barrier may be related to the consumer's attitude and feelings about the product/service offering, the brand, the seller, or even the country of origin. It also refers to personality and self-image. Consumers may resist adopting new products/services if they are patriotic and ethnocentric or if they don't perceive the innovation or the merchant/dealer to be of their "class" in terms of socio-economic status or even quality. In the field of information technology, barriers often appear in the form of fear and aversion to technology and working with computers, which lead to automation. As such, man is a social being that tends to socialize with people, to make new contacts, and any form of deprivation can lead to reluctance to accept change. Acceptance also depends on the level of education, as well as the field in which the users work. It is considered that engineers will have a better degree of acceptance of the innovation than users who work, for example, in the healthcare industry. Also, the level of technological literacy and familiarity with the innovation and its importance can play a big role in the acceptance phase. One of the main problems with the adoption of new technology is associated with distrust in its security and risks of violation of user privacy. According to the life cycle of technology adoption, users can be divided into the following groups [2]:

- Innovators (2.5%) - The first to test the product and are not afraid of risks when they decide on acceptance of innovation;
- Early adopters (13.5%) - Early adopters, like innovators, adopt a new concept product very early. However, unlike innovators, they are not technologists;
- Early Majority (34%) – This type of consumer is more sceptical compared to the previous two, however, under the influence of early adopters accept the innovation;
- Late Majority (34%) - They accept only when changes become widely accepted;
- Sceptics (16%) - Suspicious of everything new, they accept innovation only if necessary, otherwise, they reject it.

#### IV. INITIATION AND NEED FOR DIGITAL TRANSFORMATION

The need for digital transformation comes with the needs of society. The first factor influencing the initiation of digital transformation is associated with the emergence and increasing use of the Internet, with accompanying technologies (smartphones, cloud computing, online payment systems, cryptocurrencies, etc.). Another factor that initiates transformation is the constantly changing environment. For the organization to be more flexible and respond quickly to any change in demand, it often finds a solution in automation and innovation in information systems, as well as in the way processes are carried out, which in most cases are supported by representatives of Industry 4.0 technologies. The third factor that can be cited as initiating the digital transformation is the users themselves, as their response to the digital revolution. The majority of users massively switch to online shopping, due to the faster obtaining of the desired product, as well as the comfort from which they perform the activity. It can be concluded that users are the ones who set the pace for the market and who demand ease and speed when getting services/products.

Initiating digital transformation starts with [3]:

1. The question “What is happening in the world that requires action?”
2. Examine the organisation’s industry by asking the question, “What are the biggest forces influencing industry challenges?”
3. Analysis of current technological trends, by asking the question “What do we know customers need and whether we can identify what customers don’t know they need is required?”
4. Analysis of new offers on the market, by asking the question “What offers are appearing in response to changes in the market?”
5. Analysis of the current state of business and the desire for change, asking questions “If stakeholders question value and quality, what is missing, what needs to be done differently?”
6. Establishing a vision of success implies defining goals and success metrics for project outcomes.
7. Analysis of the organisation’s internal environment (availability of technical, financial resources, human expertise).

8. Communication and exchange of ideas in the collective.

##### A. *Advantages of Introducing Digital Transformation*

Digital transformation can be applied in every industry. Each type of industry operates in a competitive environment that requires rapid changes and listening to the needs of users. Therefore, digital transformation can improve and advance the way organizations deliver their value to end users. Transformation implies an ongoing process of introducing new business models and changing the way of doing business, rather than a one-time activity.

The benefits that can be realized from digital transformation are as follows [4]:

- improved efficiency,
- increased transparency,
- improved end-user experience,
- increased user engagement,
- increased productivity,
- increased agility and innovation,
- encourages collaboration and improves the employee experience,
- improves knowledge and skills of employees,
- increases competitive advantage in the market,
- cost reduction.

#### V. DIGITAL TRANSFORMATION IN THE FIELD OF EDUCATION

Digital transformation can enable educational institutions to provide a better student experience, improve their ability to attract and retain students, and support the transition to distance learning [5]. In addition, digital transformation has helped organizations adapt to the period of the COVID-19 pandemic, providing new and innovative distance learning options.

All education systems rely on data collection and processing. There is a strong need for big data technologies and analytics to provide personalized educational solutions, generate deeper insights into student progress, and facilitate better interactions between teachers and

students. Automation can ease the burden of administrative and operational tasks for teachers and school administrators.

Fields in which digital transformation can be applied are:

- reduction of paperwork related to enrollment and admission to faculties,
- use of technology to narrow the choice of students who will be accepted for studies,
- using quick answers, to get rid of routine questions,
- online monitoring of study status, without waiting for information from the student service,
- faster access to information,
- teaching materials available online,
- use of virtual reality during learning,
- cooperative learning,
- curricula focused on the future,
- flexibility, time-saving,
- better readiness of students for market needs,
- availability of necessary information at any time when it is needed,
- it promotes creativity and thinking “outside the box” in students,
- it increases the satisfaction and interest of students.

## VI. RISK MANAGEMENT IN THE DIGITAL ENVIRONMENT

The life cycle of digital transformation represents a path of innovation that requires continuous excellence, in order to respond agilely to possible global economic changes, business competitiveness, new regulations [6]. Digital transformation is not just the adoption of new software, technologies and processes that are more efficient and automated than traditional business practices, it's a completely new, innovative way of doing something that is the core of the business. This means that managers who plan to introduce digital transformation into their business, besides the benefits that transformation will bring, must also analyze

potential challenges and problems associated with the new change. Technology itself is a key factor in the emergence of risk. Risks associated with technology most often occur due to a lack of understanding of it or due to inadequate management. Establishing control over risks implies that there is a function called Risk Management within the organization or a project. Within that function, the risk is viewed through the possibility of its detection and recognition, assessment of its probability of occurrence, as well as assessment of the impact if it occurs. For an effective digital environment that meets the desired goal, it is crucial to consider risk areas beyond traditional risks [7]. For example, social networks are becoming integral to marketing, which can create a risk to brand value and reputation. Similarly, customer profiling is highlighted for a better user experience, however, the profiling process should be aligned with the protection of user data privacy. Due to the high dependence on technology, system availability must always be at a high level. Understanding risk areas is key to identifying and managing all the risks an organization may be exposed to in a digital environment. According to the Deloitte framework, digital risks are categorized into 10 areas [7]. Based on the risk areas for digital initiatives, it is necessary to design various controls as well as measures according to leading standards and industry practice. A critical aspect of defining controls is in coming to a conclusion about the nature and level of digitization of operations. So the introduction of digital transformation must go together with Risk Management in the organization.

### *A. The Impact of a Digital Transformation on Risk Management in the Educational System*

The impact and importance of technology in the field of education are increasingly in the spotlight, due to the achievements and improvements that technology can contribute to learning. However, its success will solely depend on the participation and level of engagement of stakeholders from all departments in the educational center and out. Already existing risk management plan at the university will have to change in line with the new change. Also, any decision to introduce a change must be made according to the data from the Risk Management Plan. This means that we cannot introduce a certain digital change if the university cannot support it infrastructurally, or if the new digital

change will contribute to an even greater increase in risk in the organization. The digital transformation will affect the risk management plan so that it will have to be completed with new parts that firstly involve the management of the contract that the university has concluded with the supplier of IT products [8]. This means that the contract should specify all the points that the supplier should fulfill according to the client and the contrary for the client according to the supplier. With this type of management, it will be easier to assess potential risks and it will be easier to establish adequate control based on the fulfillment or non-fulfillment of contractual obligations. The second thing is that third-party IP rights must be controlled, which means that before buying a software license, the institution must check whether the licensing method corresponds to the way of studying and accessing that software for students, whether it is about temporal or geographical access to the software. As universities own and manage a huge amount of personal data, concern for data privacy is one of the main items in the risk management plan, as they are one of the main targets of cyber attacks. Universities will have to have plans in place such as a Disaster recovery plan and Business continuity plan. The fourth thing that needs to be in plan is that IT systems in educational institutions are mostly decentralized, integration with the new system can be difficult, because we have systems of different infrastructures, and their integration itself can be very expensive. The time required to acquire a new system is to reduce the risk of expensive failed investments by finding the right solution and agreeing with the supplier on the level of integration. Also, business procedures and policies must be changed according to the new environment.

The identification of risks in the plan itself will also have to be changed in a timely manner according to the introduction of new technology. It is considered that the new potential risks of the introduction of digital change in the educational system may be the following [9]: transformation of the already existing curriculum, loss of basic cognitive competencies (writing, calculation, reading, logic), moving away from fundamental training, change in the model of the teacher (his role becomes public), reduction in the number of teaching staff, reduction in the quality of training.

## *B. The Impact of a Digital Transformation on Innovations in the Educational System*

When it comes to the impact of digital transformation on innovation, this segment offers a wide range of innovations that can be achieved by introducing and combining already existing technologies. Digital transformation provides innovators with a high level of creativity that they can use to create a new business model in the educational center itself. However, the only obstacles for innovators will be the psychological factors of students and teachers, as well as the financial and infrastructural state of the university. Therefore, research was initiated in that field, which is presented in further work through the obtained information on the readiness to accept the innovation and the given innovative proposal in the form of an application.

## VII. THE RESULTS OF EMPIRICAL RESEARCH ON STUDENT SATISFACTION WITH THE CURRENT WORK SYSTEM AT FACULTIES

Because of the benefits as well as the needs that state faculty institutions have, research work presents the problem that students encounter during their studies, and as a solution, a proposal for the implementation of an innovative application was given, which will represent the beginning of the digital transformation in the field of education.

### *A. Research Methodology*

The research part of the work is based on the analysis of student's satisfaction with the current method of studying and acquiring knowledge at studies within the state faculties of Serbia. The beginning of the research is presented through the research methodology of getting information about the current environment and students' satisfaction at state faculties. Also included in the research are questions about the psychological impact of changes on students. That is, how much students are willing to accept innovation and how ready they are to adapt to changes in the way of studying. The survey method was used as a research channel. The first phase involved creating a survey and getting in touch with respondents. In the second phase, it was necessary to analyze the collected data in order to identify a potential problem in institutions and proposed a solution.

### *B. The Task and Goal of the Research*

The task of this research was to obtain information about the current state of the state

faculties of Serbia, in the form of students' satisfaction with acquiring knowledge during their studies, obtaining the necessary timely information, as well as assessing how students are ready to the changes.

The questions in the survey were formed so they can answer the following objectives:

- get to know better and get information about users,
- get information about the satisfaction of students at the faculty,
- get information about students' satisfaction with lectures and knowledge transfer,
- get information about the acquisition of practical knowledge during studies,
- obtain information about the type of users adopting the technology,
- get information on how to get to the desired information,
- get information about the current faculty system.

### *C. Sample Research*

In the survey process, 34 respondents participated, of which the respondents were master's students of the state faculty. In the questionnaire, 25 questions were asked, of which the questions were in the form of choosing one answer, writing down the desired attitude, or rating the given question in the range of 1-5.

### *D. Research Result*

Based on the completed survey and summarized answers, the conclusion was made that the majority of students, studying for master's studies are employed, and coming to the faculty premises to attend lectures is impossible for them. As a consequence, there are difficulties in following classes and doing pre-exam duties. This initiates the problem that students who are employed will not have the same approach to accepting knowledge. Also, it was concluded that many students do not live in the city where they study for master's studies. With this information, we conclude that master's students need to be offered a more flexible way of studying, first because of the fact that most of them are employed and second because of the fact that they live in remote locations. The proposal for

this problem is in e-learning, which will enable distance learning.

The next conclusion was made about the bad transfer of information. Students who have just entered the university have a hard time finding the desired information, which can lead to anxiety and a drop in satisfaction. Also, cognition about the work of the student service leads us to the conclusion that it is necessary to have one channel of communication and information transfer, which will always be available to students and which will provide verified information.

Based on the survey, students expressed the need for a greater transfer of practical knowledge in master's studies. In response to that need, systems can be proposed, which are representatives of the digital revolution in the form of the use of Industry 4.0 technologies.

For the expressed needs and problems stated by the students in the annex, further work will propose a solution to those problems through the provision of a business proposal.

## VIII. BUSINESS PROPOSAL

As a result of the research work, a business proposal is given in the field of education with the aim of improving student satisfaction with learning at master's studies in Serbia.

The solution has a mission to improve and advance the studies of master students, developing an innovative application, which will attract new students, as well as increase and maintain the satisfaction of students during their studies. The vision of the solution is to contribute to constant progress and development in the field of education, by providing and implementing innovative solutions, which will provide both social, in the form of improving studies and increasing student satisfaction, as well as industrial benefits in the form of pushing the boundaries of current scientific achievements in the field of education.

### *A. Defining the Business Problem*

The problems that arise during studies, according to the research, are mostly related to the following facts:

- unavailability of general information in one place,
- unavailability of information about courses at the faculty,

- social anxiety, (shyness, resourcefulness),
- inability to attend traditional lectures
- reduced practical application of knowledge,
- decreased promptness, motivation and engagement of students,
- impossibility of obtaining the necessary information at the moment when the student needs it (limited work of the student service).

### *B. The Proposal Solution*

The application represents an innovative solution in the field of education with the goal of increasing student satisfaction. In the beginning, the development of the application was intended for a group of students who are studying for a master's degree in Project Management. The application form can be sent later for other study engineering programs.

Based on the results of the survey, as well as the identified problems, the business proposal will be based on the solution to the problem of acquiring the practical knowledge of master's students. Other listed problems can be input for starting the next project. The results of the satisfaction of acquiring practical knowledge during the studies were evaluated by the students as follows grades:

- grade 2 - 5.9%,
- grade 3 - 55.9%,
- grade 4 - 38.2%.

While the students unanimously stated that they need more practical knowledge during their studies. As a result of the mentioned problem, a proposal was made for the development of the application, which will have two integrated modules, the Simulation Module and the ICoin Module. The modules are explained below.

- Simulation Module

According to the presented research results, the students pointed out the need for greater acquisition of practical knowledge, as well as demonstrative situations that can be encountered in a real business environment. Guided by this, a module called Simulation is proposed to be developed, which will represent a game in the form of a simulation. The game will have certain

levels and tasks that will be based on the principle of simulating the real environment of the project manager. After a defined number of days, the student will encounter new tasks and new levels in the game. Each new task will be defined so that the student feels the real responsibility that the project manager has in the team. Some of the tasks will be for the student to form his team according to the characters in the game and according to their skills in relation to the assigned task. After that, it will be necessary for the student to make an activity plan with assigned roles. This will allow the student to see if it has been determined to overloaded team members or appointed the wrong employee for a specific task. The game will have the role of a true and realistic simulation of a project manager's role in a real project so students and organizations do not bear the consequences of their mistakes.

- ICoin Module

Student satisfaction does not only have to be closely related to the quality of the content of the faculty. It is considered that the satisfaction of the student can be achieved through an indirect approach by giving them benefits or challenges. The ICoin module implies created currency of the university, called ICoin, which will provide students with benefits in the form of exemption from regular financial expenses. The Simulation module will have points, which the student will be able to collect after each completed task in the game. Based on the level of success of the completed task within the aforementioned module, students will receive points that will encourage them to engage more in the application. Those points will be further converted into ICoin which can only be used within the university. For example, if a student collects a sufficient number of points, he will be able to use ICoin to pay for an exam or a certain item in a store or cafe at the university. With this two goals are supported, namely increasing the engagement and motivation of students at the faculty, as well as satisfaction after successfully completed activities.

### *C. The New Process of Acquisition of Practical Knowledge*

The process of acquiring practical knowledge (Fig. 1) will not be changed but improved by the presented application. The old model implies that the student encounters practical knowledge only after enrollment internship and a little during the school year. The process is improved by the



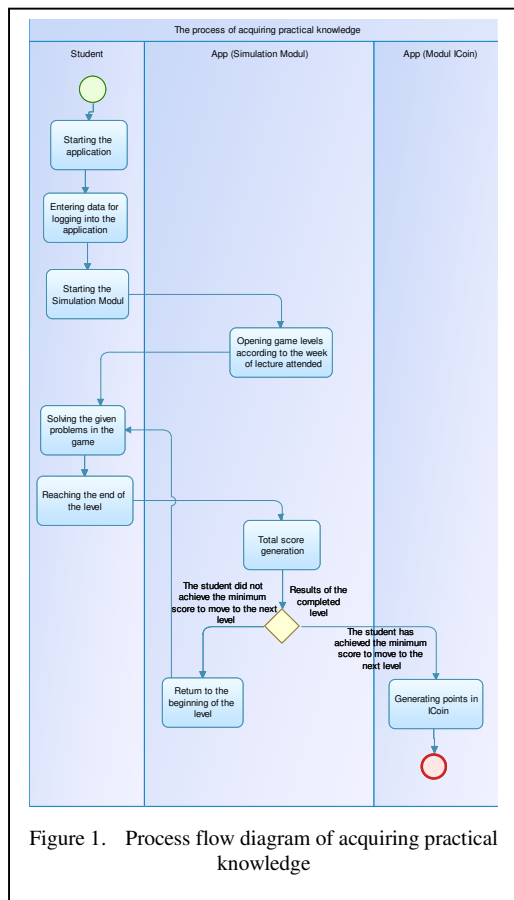

Figure 1. Process flow diagram of acquiring practical knowledge

game, which represents a simulation of a real environment of the project manager, the student will acquire practical knowledge in the field of project management. Through the levels of the game, the student meets the real tasks that the project manager has during the product life cycle. The student will have the possibility of realistic decision-making without bearing the consequences if the decision is wrong. The game offers levels, realistic problems and the ability to choose solutions. After each decision, the student gets a percentage answer about the choice of decision.

## IX. CONCLUSION

The rapid development of information systems, as well as the increase in business requirements, represent today's companies. Users have greater options in choosing and a stronger position, where they can dictate what,

when and to what extent they need. In order for companies to continue to respond flexibly to all market demands, a change is needed that would speed up or completely automate certain processes. Change means creative solutions, which can be innovations that will solve a certain problem in the organization with their effect.

Today's companies incorporate digital transformation into their daily operations as a competitive advantage they can achieve in the market. As the need to turn business towards the customer, digital transformation enables organizations to better understand the needs and desires of the market.

The research work showed the importance of digital transformation in the field of education. Also, a proposal was mentioned that would initiate digitization in educational institutions and, by its effect, improve the way of working at faculties, increase and maintain student satisfaction and initiate greater engagement on the part of them.

## REFERENCES

- [1] Roberts R., Flin R., Millar D., Corradi L. (2021). *Psychological factors influencing technology adoption: A case study from the oil and gas industry*. Robert Gordon university.
- [2] Lalić B., Savković M. (2022). Teaching materials from the subject "Digital transformation in industries". Faculty of Technical Sciences in Novi Sad
- [3] Deloitte.com. Available at: <https://www2.deloitte.com/content/dam/DeloittD/za/Documents/digital/za-Deloitte-Digital-Digital-Transformation-v3.pdf>
- [4] Veritis.com. Available at: <https://www.veritis.com/wp-content/uploads/2016/11/importance-and-benefits-of-digital-transformation-whitepaper-veritis.pdf>
- [5] Oz O., Balyer A. (2018). *Academicians' views on digital transformation in education*. Hacettepe University
- [6] Albatian.com. Available at: <https://albatian.com/en/blog-ingles/digital-transformation-life-cycle/>
- [7] Deloitte.com. Available at: <https://www2.deloitte.com/content/dam/Deloitte/in/Documents/risk/in-ra-managing-risk-digital-transformation-1-noexp.pdf>
- [8] Brownejacobson.com. Available at: <https://www.brownejacobson.com/insights/risk-management-in-digital-transformation-for-universities>
- [9] Yureva O. V., Burganova L. A., Kukushkina O. Y., Myagkov G. P., Syradoev D. V. (2020) Digital Transformation and Its Risks in Higher Education: Students' and Teachers' Attitude. *Universal Journal of Educational Research*, 8.

# Innovation Management in the Concept of Smart Cities

Bojan Krstić<sup>1</sup>, Milica Jovanović Vujatović<sup>2</sup>, Marija Jovanović<sup>3</sup>

<sup>1,2,3</sup>Faculty of Economics, University of Niš, Niš, Serbia

<sup>1</sup>bojan.krstic@eknfak.ni.ac.rs, <sup>2</sup>milica.jovanovic@eknfak.ni.ac.rs, <sup>3</sup>marijamprtracic@gmail.com

**Abstract**—Smart cities are focused on the quality of people who live and work in them, on the quality of their lives, which is why they include smart economy, smart environment, smart governance and smart mobility. The main driving force behind the growth and preservation of the competitiveness of smart cities are open innovations and the knowledge on which these innovations are based. In this sense, the goal of this paper is to indicate the way of successful management of intellectual capital (whose basis is knowledge) and open innovation process in order to determine the specifics of these management practices in smart cities. The key actors in this process and the key elements that must be developed and maintained in order to preserve the trait of smartness will be reviewed.

**Keywords** – innovation, management, smart cities

## I. INTRODUCTION

The concept of smart cities has gained importance in recent decades both in literature and in public policies. For the first time, this term was used in the 90s of the last century to indicate cities that widely apply information and communication technology in all spheres [1]. The smart city concept gains particular importance after 2010 with technological progress, the diffusion of smart devices, environmental pressure and the political support of institutions such as the United Nations, European Union and the OECD [2]. Today, this concept is increasingly focused on the quality of people and the social community in which they live and work [1]. “The smart city concept has been deployed through city-wide sophisticated ICT infrastructures capable of sensing what is happening in a city - parked cars, traffic jams, hospital beds available, energy consumption,

water or air quality, temperature, noise, etc.” [3]. According to the UN, 2030 Agenda for Sustainable Development and the New Urban Agenda cities will be inclusive, safe, resilient and sustainable [4].

A smart city is a technologically advanced area with adequate intellectual competencies for focusing on different social, economic and technical problems including smart techniques for developing superior infrastructure and services for smart city citizens [5]. The concept of smart cities includes three dimensions: environmental (pollution, waste and recycling, water and land uses), economic (GDP and labor market) and social (health, safety, education, culture) [6]. “Smart city is a community that is efficient, liveable, sustainable, and which increase a quality of life”, whose key source of efficiency and development is human resources [7]. The following are used as synonyms of this term: intelligent city, information city, knowledge city, digital/virtual city, learning city, green/eco-city, and sustainable city [8]. Namely, it is about an intelligent city that uses intelligent technologies in order to better communicate and provide better services in these cities [9]. Lombardi et al. [10] suggest that the concept of smart city is based on the following segments: smart economy, smart people, smart governance, smart environment and smart living [7,9] – Fig.1.

Some authors emphasize the importance of intangible assets as key characteristics of smart cities. It requires management of human capital (qualified labor force), infrastructural capital (high-tech communication technology), social capital (open networks) and entrepreneurial capital (creative business activities) [11].

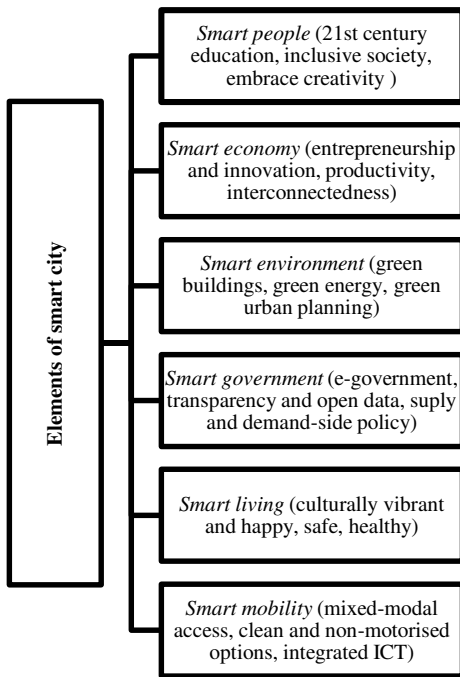

Figure 1. The concept of smart city

## II. INNOVATION AS PART OF THE INTELLECTUAL CAPITAL OF SMART CITIES

“The smart city is a smart collaborative and innovative community where co-determination and participation along with the intangible assets support value creation processes. Technology enables citizen and community participation and engagement to promote continuous innovation as a driver of urban sustainability” [4]. What the concepts of intellectual capital and smart cities have in common is based on preserving competitiveness on the basis of value creation, resilience, sustainability and quality of life [8]. The concepts of intellectual capital and smart cities are also linked to the Sustainable Development Goals, and in particular to the following: SDG 9 Industry, Innovation and Infrastructure, SDG 11 Sustainable Cities and Communities, SDG 13 Climate Action and SDG 17 Partnerships for the Goals [12]. Managing intellectual capital in smart cities enables future urban sustainability, value creation, urban competitiveness, and social and economic growth of cities [13].

Intellectual capital of the city can be seen as “the total intangible assets existing in the city and making individuals, communities, enterprises and institutions of the city function, create, update ideas, processes or products by transferring them into results of sustainable

development of the city” [14]. Intellectual assets of smart cities are based on human capital - citizen empowerment (informed, educated and participatory citizens), knowledge creation and behavioral change; social capital - social sustainability and digital inclusion; and technology capital - technology responsive to needs, skills and interests of smart city citizens, respecting their diversity and individuality [15].

Intellectual capital of smart cities includes four elements: 1) human capital – citizens’ competencies; 2) social (relational) capital - relationships between citizens, organizations, and networks; 3) process capital - smart practices, procedures and software based on the utilization of IT and high technologies; 4) renewal capital - innovation portfolio; 5) market capital - relates to institutional capital or institutional smartness; 6) environmental capital - the smartness hidden in the material heritage around citizens [8]. This indicates that the successful management of innovations in smart cities requires the management of renewal capital.

According to another understanding [16], innovations represent a segment of the structural intellectual capital of the city. According to this classification, intellectual capital includes human (individual and collective competencies, social values), structural (resources, processes and innovation) and relational capital (networking, urban connections based on city partnership and image).

Krušinskas and Bruneckienė [17] identify smart city intellectual capital as: human capital - university students, people using information technologies, readers per library, population with the highest education; process capital - value added created by one industry employee, enterprises within ICT activities, internet access; market capital - direct foreign investment, unemployed/working-age population ratio, guests accommodated; renewal capital – number of operating economic subjects, expenditure for R&D. According to this approach, innovation occurs as a result of investment in the development of smart city renewal capital. Innovation capital directly depends on R&D expenditures, and this capital is directly related to the quality of human capital and intellectual property [18].

According to Lev [19] the process of creation of intellectual capital/innovation is divided into three phases: 1) Discovery and

learning - internal renewal, acquired capabilities, networking; 2) Implementation – intellectual property, technological feasibility, Internet; 3) Commercialization – customers, performance, growth prospects. This process should enable the growth of the following intangible assets of a smart city: institutional assets (organization capital) - individual capital, knowledge (function-specific), institutional capital, professional technical knowledge and experiences, management capacity, training, learning capacity, relationship with external stakeholders, institutional credibility, reputation; framework and systems (organization capital) - policy, strategies, plan; social assets (social capital) - social system, community network, social norms, value; intellectual product (information and knowledge-related capital), R&D, reports [20].

The framework for successful intellectual capital/innovation management in smart cities includes three perspectives: a) effective and efficient service provisions to smart citizens based on successful cost management; b) value/benefit of services representing the quality of services to be provided to citizens, which requires the fair and transparent performance of local authorities; and c) local authorities treating citizens as beneficiaries - consuming services, as well as stakeholders - taxpayers, which implies that they have to satisfy the needs in order to provide continuous citizen support. Such a management framework will enable successful resource management, improved accessibility (mobility), health well-being, equal access to services, smarter services, wider community engagement, improved quality communication, security and resilience [21].

### III. KNOWLEDGE MANAGEMENT IN THE FUNCTION OF SUCCESSFUL INNOVATION MANAGEMENT IN SMART CITIES

Smart city can be seen as an arena where people can exchange and consolidate knowledge and information in a digital form at both the individual and institutional level, as well as which supports learning, schooling, education, innovation, high-technology and collaborative networking [8].

Knowledge management plays a key role in creating competitive advantage, value proposition, reducing implementation costs and enhancing organizational learning [12]. It represents the first stage of intellectual capital

management, followed by innovation management and then the management of legally protected innovations - intellectual property management [22]. Knowledge management in smart cities includes socio-technical dimensions, the emergence of urban infrastructure and technology-based services and the creation of social learning skills. It means that knowledge management in the smart context includes three basic elements: technology (data, information, urban data platform), people (knowledge in order to provide smart device applications that enable citizens to participate in the decision-making process) and institutions (such as public and private companies, universities, agencies, etc.) [23].

In order to build a smart city innovation system, knowledge-intensive activities, as well as institutions for cooperation and learning and management of collective intelligence, play a key role. Knowledge management strategies in smart cities enhance the smartness and innovative performance of the city. In order to effectively manage knowledge, it is important to create a favorable culture in such cities. People will adopt the desired cultural values if they are inspired and rewarded to behave in accordance with the realization of the goals of the smart city - constantly creation and exchanging of created knowledge [24]. Digital platforms and social media can help foster this culture in smart cities, contributing to the creation of digital knowledge that connects participants across hierarchies and locations [25]. Knowledge management should enable the creation of dynamic capabilities, which is a prerequisite for the successful development of innovations. These abilities ensure the change of resource structure, learning and acquisition and adequate understanding of acquired knowledge [24].

Knowledge management mechanisms enable the following: developing learning capabilities, sociotechnical approach to problem solving in smart cities, and integrating approach to knowledge sharing [12].

Knowledge management in the context of smart cities includes the management of three types of knowledge:

- Tacit knowledge – unstructured and unofficial personal knowledge;

including individual's experience and beliefs (citizen needs, beliefs, values, know-how and emotions);

- Explicit knowledge - official and structured knowledge (official documents, procedures and patents for advanced urban technologies and services);
- Strategic knowledge – knowledge with restricted access (R&D strategies, financial analysis, program codes, algorithms) [23].

Key stakeholders in smart cities whose knowledge needs to be managed include:

- private companies/enterprises;
- local administration;
- citizens, as the most frequent customers/users and/or co-producers of the smart services provided as well as electors who use their democratic vote to express their opinion on the priorities of politicians regarding smart cities projects;
- financing entities through taxation, with the request to be informed on the use of financial resources taken from the public sector [26].

Knowledge management practices in smart cities involve knowledge management of various entities: innovative enterprises, incubators for entrepreneurship, municipal agencies for the development of smart cities, scientific institutes and universities, city administration and government, public enterprises, citizens, the private sector and the public sector [27].

#### IV. THE ROLE OF OPEN INNOVATION IN SMART CITIES

4I (Initiate, Innovate, Instate, Integrate) Solutions Model for innovation management implies four approaches in the context of smart cities or four development stages in innovation management. First stage: Initiate refers to creating new innovation in the smart city field internally, including significant ramp-up costs. Second stage: Innovate includes pooling, integration and extension of internal capacities to create market-ready products and services (the focus is on focus on improving existing resources and capabilities). Third stage: Instate

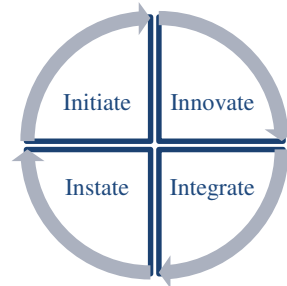

Figure 2. Model for innovation management in smart cities.

is based on utilizing existing networks within smart cities to complement products and services with new value propositions, resulting in reduction costs (associated with innovation management) reduction. The highest level of development of knowledge management practices is related to integrating external resources and skills as a superior alternative [28].

Smart cities include “multidimensional components such as ICT applications, citizen engagement and governance” [12]. This concept requires open innovation approach and involves all stakeholders of the smart city in decision-making processes [29].

Unlike traditional marketplaces in which only two types of stakeholders participate - supply and demand, the smart city concept includes collaborative platforms in which citizens, industries, universities and research centers can develop innovative products and services [30]. It is about joint innovations that require the role and contributions of different actors of smart cities. This means creating close linkages between citizens, public institutions, the business sector and educational and scientific institutions.

In smart cities, all actors participate in the decision-making process, whereby knowledge and information, which are the basis of innovation, move freely between different entities [31]. In addition, all stakeholders of smart cities are expected to participate in the innovation process in these cities within their capabilities.

It can be determined five strategies for open innovation process realization within smart cities:

- Cultivation strategy – networking citizens at all levels to exchange

knowledge as well as to develop and test ideas together;

- Replication strategy - supports collaborative innovation with other public actors;
- Partnership strategy - enhances collaborative innovation between public actors and external partners, which include private companies and non-profit organizations based on bilateral relationships;
- Networking strategy - using of the innovation assets of different organizations and individuals in order to discover, develop, and implement innovative ideas within and beyond smart city boundaries; enables better response to citizens' needs; supporting learning organizations. It includes multi-actor networks;
- Open source strategy - utilizes the Internet to attract and support external and unknown actors to develop solutions/innovations in accordance to the public actors needs [32].

Depending on two dimensions: 1) sector initiative - whether cooperation in smart cities in the innovation process is initiated by citizens or by the business sector, and 2) novelty - depending on the radicality of the innovation (completely new idea or improvement of the existing one) [33], it is possible to consider the matrix as presented on Fig. 3.

This matrix explains the types of open innovation in smart cities and the following are possible:

- Improvement of everyday life (lower left quadrant) - initiated by citizens and focused on improving of existing

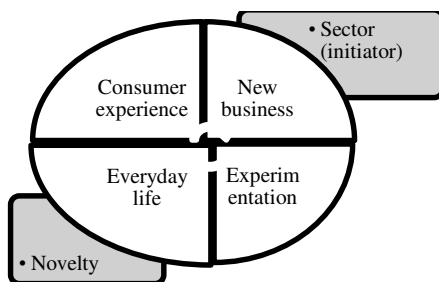

Figure 3. Open innovation matrix.

services in smart cities. It requires utilizing of intellectual and material resources, especially knowledge. As a result, it is created improved knowledge by citizens and their communities for supporting everyday life contexts;

- New citizens' experience (upper left quadrant) – it is focused on creating radical innovation in smart cities, initiating by citizens and their knowledge. It contains learning processes/activities and collaborative forms, resulting in new open collaborative forms in order to enhance citizens satisfaction;
- Experimentation (lower left quadrant) – the initiator is the private sector (companies) aiming at improving existing smart city conditions and existing knowledge/tools. It includes the implementation of new technologies in smart city and experiments. The intellectual results of these activities are based on testing the prototypes of new technologies;
- Starting new businesses (upper right quadrant) – aiming at new ideas (creating new services) and initiated by companies within smart cities which is seen as a collaborative platform. It connects different types of stakeholders and different forms of knowledge and ideas. The key contribution of this innovation process is based on new business opportunities through collaboration [33].

The key benefits and risks of collaborative innovation in smart cities include the following:

- Generation, implementation and commercialization of new ideas are facilitated including cost savings;
- Sustainable solutions are created through long-term open cooperation;
- Enhancing opportunities for startups and small and medium-sized enterprises in smart cities;
- Favorable image and branding of cities;
- Enhancing private-public-citizens collaboration;

- More intensive use of private money for R&D and innovation, but also of government money for private investments;
- Organizational, identity, institutional and cultural barriers can be more pronounced;
- Barriers to necessary organizational changes in the smart city;
- Lack of sufficient intellectual capital in the smart city;
- Possible rivalry between partners;
- Complexity of relationships in partnerships with a larger number of participants [34].

## V. CONCLUSION

In recent decades, the concept of smart cities has gained importance both in theory and in practice of modern countries, in which intellectual resources play a central role, because the smart economy is primarily based on innovation. Innovation, which is the result of R&D activities, represents an important segment of the renewal capital. In order to develop an efficient innovation system of smart cities, effective practices of knowledge management are necessary - management of implicit, explicit and strategic knowledge. Application of certain models and strategies (cultivation strategy, replication strategy, partnership strategy, networking strategy, open source strategy) can help smart cities in successful innovation management, which increasingly requires collaborative innovation activities and an open innovation approach. The approach to innovation management in smart cities will depend on the type of innovation being managed.

## ACKNOWLEDGMENT

This paper is part of the project that has received funding from the European Union's Horizon Europe research and innovation programme under grant agreement No 101059994.

## REFERENCES

[1] Albino, V., Berardi, U., & Dangelico, R. M. (2015). Smart Cities: Definitions, Dimensions, Performance, and Initiatives. *Journal of Urban Technology*, 22(1), 3-21.

[2] Cocchia, A. (2014). Smart and digital city: a systematic literature review. In R. P. Dameri & C. Sabroux (Eds.), *Smart City: How to Create Public and Economic Value with High Technology in Urban Space* (pp. 13-43).

[3] Oliveira, A., & Campolargo, M. (2015). From Smart Cities to Human Smart Cities. In *48th Hawaii International Conference on System Sciences*. IEEE Computer Society.

[4] Romanelli, M. (2022). Smart cities and intellectual capital for urban innovation and future. *European Conference on Knowledge Management*, 23(2), 1010-1016.

[5] Bakici, T., Almirall, E., & Wareham, J. (2013). A smart city initiative: The case of Barcelona. *Journal of the Knowledge Economy*, 4(2), 135-148

[6] Alfaro-Navarro, J. L., López-Ruiz, V. R., & Nevado Pena, D. (2017). A new sustainability city index based on intellectual capital approach. *Sustainability*, 9(5), 860.

[7] Jurenka, R., Caganova, D., Hornakova, N., & Starecek, A. (2017). Smart city in terms of social innovations and human capital. In *Smart City 360°. The second EAI International Summit, Smart City 360°, Bratislava, Slovakia, November 22-24, 2016*.

[8] Dameri, R. P., & Ricciardi, F. (2015). Smart city intellectual capital: an emerging view of territorial systems innovation management. *Journal of Intellectual Capital*, 16(4), 860 - 887.

[9] Harrison, C., Eckman, B., Hamilton, R., Hartswick, P., Kalaganam, J., Paraszczak, J., & Williams, P. (2010). Foundations for Smarter Cities. *IBM Journal of Research and Development*, 54(4), 1-16.

[10] Lombardi, P., Giordano, S., Farouh, H., & Yousef, W. (2012). Modelling the Smart City Performance. *Innovation: The European Journal of Social Science Research*, 25(2), 137-149.

[11] Kourtit, K., & Nijkamp, P. (2012). Smart Cities in the Innovation Age. *Innovation: The European Journal of Social Science Research*, 25(2), 93-95.

[12] Israilidis, J., Odusanya, K., & Mazhar, M. U. (2021). Exploring knowledge management perspectives in smart city research: A review and future research agenda. *International Journal of Information Management*, 56, 101989.

[13] Viedma, J. M. (2004). CICBS: a methodology and a framework for measuring and managing intellectual capital of cities. A practical application in the city of Mataró. *Knowledge Management Research & Practice*, 2(1), 13-23.

[14] Krusinskas, R., & Bruneckiene, J. (2011). Measurement of intellectual capital of Lithuanian cities, in Knowledge for Market Use 2011: New Generation of Workers (Generation Y). In *Proceedings of the international scientific conference, 24-25 November 2011, Palacký University Olomouc* (pp. 72-78).

[15] Angelidou, M. (2015). Smart cities: A conjuncture of four forces. *Cities*, 47, 95-106.

[16] Uziene, L. (2013). City's intellectual capital framework: The performance measurement point of view. *Economics and Management*, 18(2), 198-208.

[17] Krušinskas, R., & Bruneckienė, J. (2015). Measurement of intellectual capital of Lithuanian cities by a composite index. *Journal of Business Economics and Management*, 16(3), 529-541.

- [18] Chang W. S., & Hsieh J. J. (2011). Intellectual capital and value creation-is innovation capital a missing link? *International Journal of Business and Management*, 6(2), 3-10.
- [19] Lev, B. (2001). *Intangibles: Management, measurement, and reporting*. Washington, D.C.: The Brookings Institute Press.
- [20] Wataya, E., & Shaw, R. (2019). Measuring the value and the role of soft assets in smart city development. *Cities*, 94, 106-115.
- [21] Wataya, E., & Shaw, R. (2022). Soft Assets Consideration in Smart and Resilient City Development. *Smart Cities*, 5(1), 108-130.
- [22] Krstić, B. (2014). *Upravljanje intelektualnim kapitalom preduzeća*. Ekonomski fakultet, Univerzitet u Nišu.
- [23] Roblek, V., & Meško, M. (2020). Smart city knowledge management: Holistic review and the analysis of the urban knowledge management. In *The 21st Annual International Conference on Digital Government Research* (pp. 52-60).
- [24] Abdalla, W., Suresh, S., & Renukappa, S. (2020). Managing knowledge in the context of smart cities: An organizational cultural perspective. *Journal of Entrepreneurship, Management and Innovation*, 16(4), 47-85.
- [25] Warner, K. S., & Wäger, M. (2019). Building dynamic capabilities for digital transformation: An ongoing process of strategic renewal. *Long Range Planning*, 52(3), 326-349.
- [26] Zuccardi Merli, M., & Bonollo, E. (2014). Performance measurement in the smart cities. In *Smart city* (pp. 139-155).
- [27] Costanzo, A., Faro, A., Giordano, D., & Spampinato, C. (2016). Implementing Cyber physical social systems for smart cities: A semantic web perspective. In *Proceeding of the 13th IEEE Annual Consumer Communications & Networking Conference (CCNC)*. IEEE. Las Vegas, NV, USA.
- [28] Grab, B., & Ilie, C. (2019). Innovation management in the context of smart cities digital transformation. In *Economic and Social Development: Book of Proceedings* (pp. 165-174).
- [29] Mainka, A., Castelnovo, W., Miettinen, V., Bech-Petersen, S., Hartmann, S., & Stock, W. G. (2016). Open innovation in smart cities: Civic participation and co-creation of public services. *Proceedings of the Association for Information Science and Technology*, 53(1), 1-5.
- [30] Praharaj, S., & Han, H. (2019). Cutting through the clutter of smart city definitions: A reading into the smart city perceptions in India. *City, Culture and Society*, 18, 100289.
- [31] Schaffers, H., Komminos, N., Pallot, M., Trousse, B., Nilsson, M., & Oliveira, A. (2011). Smart cities and the future internet: Towards cooperation frameworks for open innovation. In *The Future Internet Assembly* (pp. 431-446). Heidelberg, Berlin: Springer.
- [32] Eggers, W., & Singh, S. K. (2009). *The Public Innovator's Playbook: Nurturing Bold Ideas in Government*.
- [33] Leminen, S., & Westerlund, M. 2015. Cities as Labs: Towards Collaborative Innovation in Cities. In P. Lappalainen, M. Markkula & H. Kune (Eds.), *Orchestrating Regional Innovation Ecosystems* (pp. 167-175).
- [34] Ojasalo, J., & Kauppinen, H. (2016). Collaborative innovation with external actors: an empirical study on open innovation platforms in smart cities. *Technology Innovation Management Review*, 6(12).





# Role of Artificial Intelligence for Promoting Financial Inclusion

Reena Agrawal<sup>1</sup>

<sup>1</sup>Jaipuria Institute of Management, Gomti Nagar, Lucknow, India

<sup>1</sup>dr.agrawal.reena@gmail.com

**Abstract**—Artificial intelligence (AI) has penetrated services sectors around the world. With 1.4 billion adults still without access to formal banking and about 50% of population in Middle and East Africa, approximately 38% in Central and South America, about 33% in East Europe and close to 24% people in Asia Pacific region are financially excluded, the current research is taken up to examine the role of Artificial Intelligence in promoting financial inclusion and investigate how the use of Artificial Intelligence can help the financial service providers to offer services at affordable rates to low income group people. The findings of the study demonstrated that adoption of artificial intelligence technologies will not only help them to tap the underserved and unserved but also help in reducing the operating costing and enhance operational efficiency use of AI algorithms can also help them in avoiding fraud and credit risk.

**Keywords** - unbanked, financial technology, artificial intelligence, financial inclusion

## I. INTRODUCTION

About 1.4 billion adults still do not have access to formal banking, with about 50% of unbanked people living in Middle and East Africa, about 38% living in Central and South America, roughly 33% people living in East Europe and near about 24% people living in Asia Pacific region are financially excluded [1-3]. Global Financial index reported that during 2017 almost 1.7 billion grown-ups were unbanked [4]. In South Sudan, merely 9% adults had bank account, likewise, approximately 70% people in Latin America were either under banked or unbanked [5]. International Finance Corporation reported that above 200 million small, micro, and medium enterprises in emerging economies lack right to use financial services [6]. These issues

can be resolved by promoting financial inclusion. The financial inclusion ensures that low income individuals and micro enterprises have access to financial services and products at reasonable rates to meet their day to day requirements [7]. Financial Inclusion is fundamental in enhancing general quality of live and general well-being of underprivileged groups.

In spite of the speedy development of Fintech, its effect on financial inclusion has been restricted. This is largely due to the absence of wide-ranging data on Fintech features. Fintech novelties like peer-to-peer lending use of mobile money have been quite effective, though it was also found that across different regions borrowing activity is far less prevalent than account holding [8-10]. Artificial intelligence is rapidly evolving and is bringing economic, social and political, transformation in emerging markets. Artificial intelligence -founded solutions are expected to arise as game-changers that have huge effects on escalating financial access to underprivileged people. The traditional banking organizations are usually reluctant and unwilling to service low-income individual and micro businesses due to inefficient processes and high operation costs [11]. Artificial intelligence has penetrated services sectors around the world. Thus the current research is taken up to examine the role of artificial intelligence in endorsing financial inclusion and investigate how the Artificial Intelligence can help the financial service providers to offer services at reasonable rates to under-privileged and unserved people [12-15].

## II. MEDIA LITERATURE REVIEW

### A. *Financial Inclusion*

Financial inclusion has crucial and pertinent role in Sustainable Development Goals [16]. Financial inclusion has been major concern for financial regulators across the world. In emerging economies like Asia, South America, and Africa, financial inclusion is especially essential [17]. Financial Inclusion inspires access to financial facilities at affordable rates, and thus stimulates well-being and economic growth. Those who need financial access the most have no or little access to financial services [18]. As per World Bank Financial inclusion means “individuals and businesses have access to useful and affordable financial products and services that meet their needs—transactions, payments, savings, credit and insurance delivered in a responsible and sustainable way” [19]. The European Commission defined financial exclusion as the “situation where individuals are faced with access challenges in the use of financial services and products that can help satisfy their needs and wants and to allow them to live normal social life in their communities” [20]. “Financial inclusion is the sustainable provision of affordable financial services that bring the poor into the formal economy” [21]. “Financial inclusion is the use of formal financial services by the poor” [22,23]. Financial inclusion is availability and usage of inexpensive basic financial services to everyone [24-27].

### B. *Artificial Intelligence*

Artificial intelligence was established as a discipline approximately 70 years ago, but its avid application has been noticed in recent times, facilitated by developments in data storage, computing power, and communications systems and network [15].

“By ‘general intelligent action’ we wish to indicate the same scope of intelligence as we see in human action: that in any real situation behavior appropriate to the ends of the system and adaptive to the demands of the environment can occur, within some limits of speed and complexity” [28].

Intelligence usually means “the ability to solve hard problems” [29].

“AI is concerned with methods of achieving goals in situations in which the information available has a certain complex character. The methods that have to be used are related to the

problem presented by the situation and are similar whether the problem solver is human, a Martian, or a computer program” [30].

Artificial intelligence is the “simulation of machines to imitate intelligent human behavior” [31]. Artificial intelligence can thus be defined as the imitation of human intellect by machines that are trained to think and perform like humans.

### C. *Artificial Intelligence and Financial Inclusion*

Artificial intelligence technologies are infiltrating financial sectors across the world. The use of these AI in emerging economies allows financial organizations to mechanize their day to day operations and processes and to take advantage of big data sources to resolve problems and overcome obstacles— including excessive cost of rendering services to low-income and rural clients and creating customer distinctiveness and soundness—that inhibits the delivery of financial services to countless consumers [12]. Benefits of financial inclusion can only be realized responsible adoption through of artificial intelligence technologies by financial service providers, in competitive market settings, and through increased investment in required infrastructure. Artificial intelligence technologies and big data can make it possible for financial service providers offer financial product and services at reduced cost and thus promote financial inclusion [9].

If financial organizations combine telephony data using artificial intelligence technologies with traditional credit recording models they will be able to considerably improves the daily performance [32]. Use of artificial intelligence technologies in banking can lead to an efficient and economical ways to deliver financial products to financially excluded people. They also stated that big data-driven simulations can be conducted for psychometric assessment to capture necessary info that can facilitate prediction of applicants' attitude, integrity, and loan repayment behavior [33].

Scholars who examined the influence of artificial intelligence technologies on financial inclusion stated that financial service providers can use artificial intelligence technologies and its numerous applications to attain inclusion of the poor having low-income and micro business organizations [20]. The study disclosed that artificial intelligence technologies has strong impact on financial inclusion and it is especially

useful in risk measurement, risk detection, and risk management. The study also stated that artificial intelligence technologies resolved the problem of asymmetry of information, and also extended support to customers through artificial intelligence aided bots. Deficiency of credit history create obstacles for millennials, the artificial intelligence technologies and big data can assist in creating credit scores for millennials [34].

Artificial intelligence technologies hold large promise for people and society [35]. Artificial intelligence technologies will reduce biases against deprived groups [36,37]. Blockchain disruptions would transform in big way the financial sector in times to come [29]. By leveraging artificial intelligence technologies financial organizations can offer custom-made products to consumers and that too at reasonable cost [38,39]. Artificial intelligence technologies had potential to promote financial inclusion and benefit the deprived groups [40,41].

### III. OBJECTIVE OF STUDY

The current research is taken up to scrutinize the role of Artificial Intelligence technologies in stimulating financial inclusion and investigate how the use of Artificial Intelligence can help the financial service providers to offer services at reasonable rates to low income group people. The study attempts to comprehend the increasing use and benefits of Artificial Intelligence technologies in stimulating financial inclusion. The study proposes to find answers to the following research questions:

RQ1: Does Artificial Intelligence technologies can help in promoting financial inclusion?

RQ2: What benefits can financial service providers derive on adoption of Artificial Intelligence technologies?

### IV. METHODOLOGY

The current study adopted a quantitative analysis. This study reviewed research articles published in web of science, google scholar, academia, research gate, and Scopus. This step resulted in 73 articles. The key words used in our search were ‘artificial intelligence’, ‘financial inclusion’, ‘use of artificial intelligence in stimulating financial inclusion’, ‘and role of artificial intelligence in enhancing financial inclusion’. The search for articles’ sources

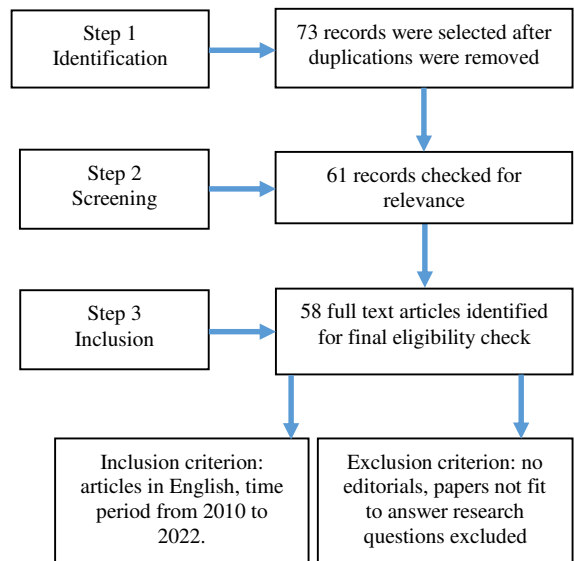

Figure 1: Research Process Adopted in the Study

included business journals, management journals, and economics journals.

The inclusion criterion were only the articles written in English were screened, the time period covered was from 2010 to 2022. The exclusion criterion was no editorials were considered. Papers that were not of use to answer research questions were eliminated. The screening was done in multiple stages: (i) duplicate papers were removed, resulting in 73 articles that then used in next stage; (ii) second stage produced 61 articles which were used for further study; (iii) the third stage included review of the full text of research articles by the authors, during 2010-2022, of which 58 articles were found very relevant for final review. Fig. 1 demonstrates the steps used in the creation of the database for this study.

### V. FINDINGS AND ANALYSIS

Artificial intelligence technologies can be described as a sequence of techniques, systems, and technology that exhibit intellectual conduct by scrutinizing their situations and performing actions—with some independence—toward attaining pre-determined outcomes. Increased penetration of mobiles, reduced cost of internet connectivity, and improved computing power have help in generating rich new and real-time data through diverse digital devices. Advances in storage of data, energy reliability, computation power and analytical skills have made it possible to examine the sea of instantaneous data. Thus it is feasible for financial service providers in

emerging market to begin incorporating artificial intelligence technologies into their day to day business operations. There are numerous merits in making use of artificial intelligence technologies for promoting financial inclusion, to mention some as follows:

- Artificial intelligence technologies can make simpler the process of account opening for un-banked population. Artificial intelligence algorithms can be used to automate the account opening procedure at banks, and eradicate the troublesome paper work that often dishearten un-banked people from opening bank account [14].
- As a result of frauds, approximately 20% of bank loans in India result into bad loans [42]. Loan frauds are projected at USD 2 billion per annum, resulting in high-interest rates and low trust [43]. Also, Artificial intelligence technologies can do customer authentication and assist in due diligence activities by helping them to understand the purpose and nature of transaction. Artificial intelligence technologies will raise red-flags if there is suspicion of fraudulent activities [44].
- By automating operating processes, the artificial intelligence technologies can facilitate higher volumes of micro transactions which are very low in value, thus can help underserved people to become part of financial markets. Artificial intelligence technologies can thus significantly diminish the operating costs for financial service organizations [14].
- Artificial intelligence technologies can help world-based developing financial organizations and clients to abide innumerable regulatory time-consuming necessities and religious prescriptions [45].
- Artificial intelligence technologies can offer smart and customized financial services and products to customers. Artificial intelligence technologies can analyze people's financial behavior and conduct, and can offer advice and tailored services and thus enhance financial inclusion [45].

- Financial service providers can make use of predictive analytics to mimic diverse scenarios that can't be attained in the real world. This contains Financial service providers generating trust by addressing bias and error by using algorithmic, lending responsibly, managing and avoiding cyber risk, and taking necessary consent for the use of consumer data [46].
- Artificial intelligence technologies help in creating credit history. Artificial intelligence applications allow to build a credit history of unbanked people as well. Artificial intelligence application can make use of demographic and behavioral traits of people for example contact lists, location, social media information, and can use machine learning models to work on these data and generate predictions about the potential repayment by the person [14].

Artificial intelligence technologies have prospective to augment financial inclusion. Financial service providers should make use of artificial intelligence technologies to build relationship with their potential customers, especially the one not yet served by conventional financial service providers. The artificial intelligence technologies-driven advances will enhance productivity, improve living standard, unlock entrepreneurial capability, and decrease economic inequities. However, the main challenge for the financial service providers is to create the futuristic vision, mission, and ideologies that have larger purpose. The extent and pace and of adoption of artificial intelligence technologies, and the degree of inclusion benefits realized, also depends on intent and efforts of the businesses, policy maker, financial regulators, and investors to generate congenial environment which ensure and facilitate accountable and viable assimilation of artificial intelligence technologies in financial product and services.

## VI. RESEARCH IMPLICATIONS

Financial inclusion is a major concern of global financial policy makers and regulators such as International Monetary Fund, European Commission and World Bank. With countries big or small straddling to achieve sustainable development goals promoting financial inclusion can directly and indirectly help in attaining eight out of seventeen goals. The findings of the current study will give food for thought to the

policy makers, financial regulators, investors, and financial service providers. It will encourage traditional players to gather courage and invest in technology infrastructure to reap long term benefits from adopting artificial intelligence. Increased use of artificial intelligence technologies will benefit to all the stakeholders, it will fetch profits for financial service providers, will help in financial inclusion a major concern of national as well as global financial regulators, will bring financial service offering to people living at grass root level and this will ensure their contribution in the economic development of the region and the nation.

## VII. LIMITATIONS AND FUTURE RESEARCH

Like any other study this study is also not free from limitations. This research is only a quantitative study and if qualitative aspects are also added to such a study it would give deeper insights. Future scholars can plan to conduct in integrated study having quantitative as well as qualitative aspects. Interviews and interactions with policy makers, regulators and top decision makers in the financial organizations would have helped get their perspective as well. Cross country studies would have helped in doing assessment at ground zero.

## REFERENCES

- [1] World Bank. (2022). *Financial Inclusion Overview*. World Bank, March 29, 2022. Retrieved on Oct 27, 2022 from <https://www.worldbank.org/en/topic/financialinclusion/overview>
- [2] World Economic Forum. (2022). *Four things to know about financial inclusion around the world right now*. World Economic Forum. Retrieved on Oct 27, 2022 from <https://www.weforum.org/agenda/2022/07/global-digital-financial-inclusion-index/>
- [3] Global Finance. (2021). *World's most unbanked countries 2021*. Global Finance, Feb. 17, 2021. Retrieved on Oct 27, 2022 from <https://www.gfmag.com/global-data/economic-data/worlds-most-unbanked-countries>.
- [4] World Bank. (2018). *Financial Inclusion Overview*. World Bank, Washington, DC. <https://www.worldbank.org/en/topic/financialinclusion/overview#1>
- [5] Rojas-Torres, D., Kshetri, N., Hanafi, M. M., & Kouki, S. (2021). Financial technology in Latin America. *IT Professional*, 23(1), 95-98.
- [6] Bruhn, M., Hommes, M., Khanna, M., Singh, S., Sorokina, A., & Wimpey, J. S. (2017). *MSME finance gap: assessment of the shortfalls and opportunities in financing micro, small, and medium enterprises in emerging markets* (No. 121264, pp. 1-80). The World Bank.
- [7] World Bank. Development Research Group. Finance, & Private Sector Development Team. (2018). *The little data book on financial inclusion 2018*. World Bank Publications.
- [8] Yin, X., Xu, X., Chen, Q., & Peng, J. (2019). The sustainable development of financial inclusion: how can monetary policy and economic fundamental interact with it effectively?. *Sustainability*, 11(9), 2524.
- [9] Bazarbash, M., & Beaton, K. (2020). Filling the gap: Digital credit and financial inclusion. *IMF Working Papers*, 2020(150).
- [10] Barajas, A., Beck, T., Belhaj, M., & Naceur, S. B. (2020). Financial inclusion: what have we learned so far? What do we have to learn?. *IMF Working Papers*, 2020(157).
- [11] Kshetri, N. (2014). *Global entrepreneurship: Environment and strategy*. Routledge.
- [12] Kshetri, N. (2021). The role of artificial intelligence in promoting financial inclusion in developing countries. *Journal of Global Information Technology Management*, 24(1), 1-6.
- [13] How, M. L., Cheah, S. M., Khor, A. C., & Chan, Y. J. (2020). Artificial intelligence-enhanced predictive insights for advancing financial inclusion: A human-centric ai-thinking approach. *Big Data and Cognitive Computing*, 4(2), 8.
- [14] Ozili, P. K. (2021). Big data and artificial intelligence for financial inclusion: benefits and issues. *Artificial Intelligence Fintech, and Financial Inclusion*.
- [15] Biallas, M., & O'Neill, F. (2020). Artificial intelligence innovation in financial services.
- [16] World Bank. (2020). *The World Bank Financial Inclusion*.
- [17] Nawaz, T. (2018). Lifting the lid on financial inclusion: Evidence from emerging economies. *International Journal of Financial Studies*, 6(2), 59.
- [18] Tok, Y. W., Tan, S. L., & Chansrinoyom, T. (2021). Do Innovations in Lending Help SMEs?. *ADB-IGF Special Working Paper Series "Fintech to Enable Development, Investment, Financial Inclusion, and Sustainability"*.
- [19] World Bank. (2018). *Financial inclusion*. Retrieved on Oct 13, 2022 from <https://www.worldbank.org/en/topic/financialinclusion>
- [20] Mhlanga, D. (2020). Industry 4.0 in finance: the impact of artificial intelligence (ai) on digital financial inclusion. *International Journal of Financial Studies*, 8(3), 45.
- [21] United Nations. (2016). *Digital financial inclusion*. International Telecommunication Union (ITU), issue brief series, inter-agency task force on financing for development
- [22] Bruhn, M., & Love, I. (2014). The real impact of improved access to finance: Evidence from Mexico. *The Journal of Finance*, 69(3), 1347-1376.
- [23] Beck, T., Demirgüç-Kunt, A., & Levine, R. (2007). Finance, inequality and the poor. *Journal of economic growth*, 12, 27-49.
- [24] Ozili, P. K. (2018). Impact of digital finance on financial inclusion and stability. *Borsa Istanbul Review*, 18(4), 329-340.
- [25] Ozili, P. K. (2019). Blockchain finance: Questions regulators ask. In *Disruptive innovation in business*

- and finance in the digital world* (Vol. 20, pp. 123-129). Emerald Publishing Limited.
- [26] Ozili, P. K. (2021, October). Financial inclusion research around the world: A review. In *Forum for social economics* (Vol. 50, No. 4, pp. 457-479). Routledge.
- [27] Allen, F., Demirguc-Kunt, A., Klapper, L., & Peria, M. M. (2016). Foundations of financial inclusion. *Journal of Financial Intermediation*, 27, 1-30.
- [28] Newell, A., & Simon, H. A. (1976). Computer science as empirical inquiry: symbols and search. *Communications of the ACM*, 19(3): 113-126
- [29] Malinga, S. (2019). *How AI helped Tyme Bank gain 670K customers*. IT Web
- [30] McCarthy, J. (1988). Mathematical logic in artificial intelligence. *Daedalus*, 297-311.
- [31] Kok, J. N., Boers, E. J., Kusters, W. A., Van der Putten, P., & Poel, M. (2009). Artificial intelligence: definition, trends, techniques, and cases. *Artificial intelligence*, 1, 270-299.
- [32] Óskarsdóttir, M., Bravo, C., Sarraute, C., Vanthienen, J., & Baesens, B. (2019). The value of big data for credit scoring: Enhancing financial inclusion using mobile phone data and social network analytics. *Applied Soft Computing*, 74, 26-39.
- [33] Kandpal, V., & Khalaf, O. I. (2020). Artificial intelligence and SHGs: enabling financial inclusion in India. In *Deep Learning Strategies for Security Enhancement in Wireless Sensor Networks* (pp. 291-303). IGI Global.
- [34] Agarwal, S., Alok, S., Ghosh, P., & Gupta, S. (2020). Financial inclusion and alternate credit scoring for the millennials: role of big data and machine learning in fintech. *Business School, National University of Singapore Working Paper, SSRN, 3507827*.
- [35] Vladeck, D. C. (2015). Consumer protection in an era of big data analytics. *Ohio NUL Rev.*, 42, 493.
- [36] Philippon, T. (2019). *On fintech and financial inclusion* (No. w26330). National Bureau of Economic Research.
- [37] Qureshi, S. (2020). Why data matters for development? Exploring data justice, micro-entrepreneurship, mobile money and financial inclusion. *Information Technology for Development*, 26(2), 201-213.
- [38] Boot, A. W., Hoffmann, P., Laeven, L., & Ratnovski, L. (2020). Financial intermediation and technology: What's old, what's new?.
- [39] Arner, D. W., Buckley, R. P., Zetsche, D. A., & Veidt, R. (2020). Sustainability, FinTech and financial inclusion. *European Business Organization Law Review*, 21, 7-35.
- [40] Demirguc-Kunt, A., Klapper, L., Singer, D., & Ansar, S. (2018). *The Global Findex Database 2017: Measuring financial inclusion and the fintech revolution*. World Bank Publications.
- [41] Breza, E., Kanz, M., & Klapper, L. F. (2020). *Learning to navigate a new financial technology: Evidence from payroll accounts* (No. w28249). National Bureau of Economic Research.
- [42] Suberg, W. (2017). Indian Bank Wants Joint Effort to Share Data on Blockchain, The Coin Telegraph.
- [43] Pitti, A. (2018). Why India can become the global center for blockchain innovation. *Nasdaq*.
- [44] Perez, B., & Soo, Z. (2017). China a fast learner when it comes to artificial intelligence-powered fintech, experts say. *South China Morning Post*.
- [45] Decosmo, J. (2019). How Fintechs Can Leverage Artificial Intelligence. *Récupéré de: <https://www.forbes.com/sites/forbestechcouncil/2019/08/09/how-Fintechs-canleverage-artificial-intelligence>*.
- [46] Philippon, T. (2019). *On fintech and financial inclusion* (No. w26330). National Bureau of Economic Research.

# Modeling the Time-based Maintenance Strategies with Petri Nets

Ilija Hristoski<sup>1</sup>, Tome Dimovski<sup>2</sup>

<sup>1</sup>Faculty of Economics – Prilep/“St. Kliment Ohridski” University – Bitola,  
Prilep, North Macedonia

<sup>2</sup>Faculty of Information and Communication Technologies/“St. Kliment Ohridski”  
University – Bitola, Bitola, North Macedonia

<sup>1</sup>ilija.hristoski@uklo.edu.mk, <sup>2</sup>tome.dimovski@uklo.edu.mk

**Abstract**—The appliance of any maintenance strategy can considerably reduce the risks of failures, which can significantly improve the system’s performability, i.e. its ability to perform in a given operational environment in the presence of failures. The paper aims to elaborate on the two most dominant time-based maintenance strategies in use today, including the preventive and the predetermined ones, by proposing corresponding stochastic Petri Net models. Such models can provide solid frameworks for the evaluation of the efficiency of both approaches vis-à-vis a variety of input parameters. In addition, the proposed models can provide valuable insights into the dynamics of the two maintenance strategies by carrying out various ‘what-if’ analyses regarding different working scenarios.

**Keywords** - maintenance strategy, modeling, stochastic Petri Nets, preventive maintenance, predetermined maintenance

## I. INTRODUCTION

Web services today rely on critical Internet infrastructure, comprised of data centers, server farms, networking equipment, communication facilities, transmission media, software, etc. that are responsible for hosting, storing, processing, and providing the information that comprises websites, apps, and content. The Industry 4.0 paradigm encompasses the utilization of a myriad of networked IoT devices, robots, sensors, automated machines, and computers. All of these hardware components, including the software that gears it up, have to be continuously and appropriately maintained to keep them up and running. Since failures are

inevitable phenomena in the tech world, risks and threats of both hardware and software failures are omnipresent, so they have to be rationally accepted and dealt with, in terms that they have to be properly identified/recognized, analyzed/evaluated, and controlled/managed. Denial and deliberate ignorance of thoughtful planning and non-undertaking risk management activities can cause damage and can incur severe consequences not only to tangible assets (hardware, software, data) but also to intangible ones (company’s reputation and image, customers’ trust and loyalty), leading towards financial losses due to customer dissatisfaction and dissipation. Therefore, risks cannot be underestimated, but rather they have to be treated proactively and efficiently.

In this regard, the paper focuses on time-based maintenance strategies that can be thought of as risk management approaches that can significantly help in mitigating the risks of physical assets’ failures. These include three variations of preventive maintenance strategies as well as the predetermined maintenance, as a special case of preventive maintenance.

The paper is structured as follows. Section II briefly elaborates on the most prominent research related to modeling various maintenance strategies with Petri Nets. Section III presents the proposed stochastic Petri Net models that capture the essence of two major time-based maintenance strategies: preventive and predetermined maintenance. The last section discusses the benefits and drawbacks of the presented models and concludes.



## II. RELATED RESEARCH

Managing risks of failures through the application of various maintenance strategies has become a subject of extensive research in recent years, fostered by the need to optimize maintenance costs and increase systems' availability and reliability. Much of this research has been carried out using various classes of Petri Nets (PNs), which have all proven to provide powerful graphical and mathematical formalisms suitable for algorithmic modeling and evaluation of complex discrete-event dynamic systems and processes exhibiting features such as parallel/concurrent execution, blocking, mutual exclusion, iterative repetition, and choice making. In this context, PNs have been utilized with the general aim to quantify the effects of various maintenance strategies on particular systems in practice.

The research based on the utilization of Petri Nets for maintenance purposes stretches back to 1998 when they were used to assess early failure detection and fault isolation, for district heating and cooling system's health monitoring and improvement of preventive maintenance [1] and in 1999 when they were used for building a model and an algorithm to find the minimal cut-sets of a coherent fault tree [2], as well as to evaluate various maintenance strategies in manufacturing systems [3]. Later on, in 2004, Petri Nets were used to model and analyze scheduled maintenance systems [4], and in 2009, they were used to carry out research on maintenance processes' modeling techniques vis-à-vis the evaluation of specific maintenance performance indexes [5].

During the last decade, the research on maintenance modeling using PNs has dramatically intensified, involving various classes of PNs, including Generalized Stochastic Petri Nets (GSPNs) [6-8], Colored Petri Nets (CPNs) [9-12], and Deterministic and Stochastic Petri Nets (DSPNs) [13].

Lately, Petri Nets were used to model and evaluate the preventive maintenance processes in technological facilities [11] and aircraft [12] in 2021, to help improve the reliability and availability of an electric power system's infrastructure [14] (2021), as well as to plan and optimize maintenance logistics of small hydroelectric power plants [15] in 2022. Reference [16] proposed a methodology to properly define the optimal structure and

properties of reduced complex Petri Net models used in maintenance modeling (2022). An overview of the major maintenance strategies, including their corresponding generic stochastic Petri Net models that can be utilized for availability and reliability analysis of the modeled systems vis-à-vis various input parameters and working scenarios, can be found in [17] (2022).

## III. PETRI NET MODELS OF TIME-BASED MAINTENANCE STRATEGIES

Time-based maintenance strategies refer to those preventive strategies where the scheduling of the next planned maintenance operations is based solely on time-lapse and not on other factors. The subsequent four maintenance strategies belong to this category. What follows is a brief description of each one. All the models utilize the class of Deterministic and Stochastic Petri Nets (DSPNs) [18,19] and are developed and validated using the TimeNET 4.5 software tool.

A constituent part of all presented DSPN models is the sub-model representing the modeled system, which is subject to a certain time-based maintenance strategy, as shown in Figs. 1, 3, 5, and 7. The system is prone to failures. As such, it may undergo a series of consecutive failures and repairs, thus alternating between two possible states/modes: operational (a token in the place  $P_{sys\_WORK}$ ) and non-operational (a token in the place  $P_{sys\_FAIL}$ ). The failures occur with a rate of  $\lambda_{sys} = 1/MTTF$  (MTTF stands for Mean Time to Failure), denoted by the firing of the exponential transition  $T_{sys\_MTTF}$ , and repairs last, on average, MTTR time units (MTTR stands for Mean Time to Repair), meaning that the exponential transition  $T_{sys\_MTTR}$  fires with a rate of  $\mu_{sys} = 1/MTTR$ , the repair rate.

### A. Preventive Maintenance without Time Shifts

This approach includes a routine maintenance plan according to which maintenance operations always occur at predetermined, fixed time points to keep the equipment and assets functioning, thus avoiding costly unplanned downtimes and reducing or eliminating their unavailability due to unexpected equipment breakdowns. The time points when preventive maintenance is scheduled are fixed, no matter whether a system failure occurred previously or not.

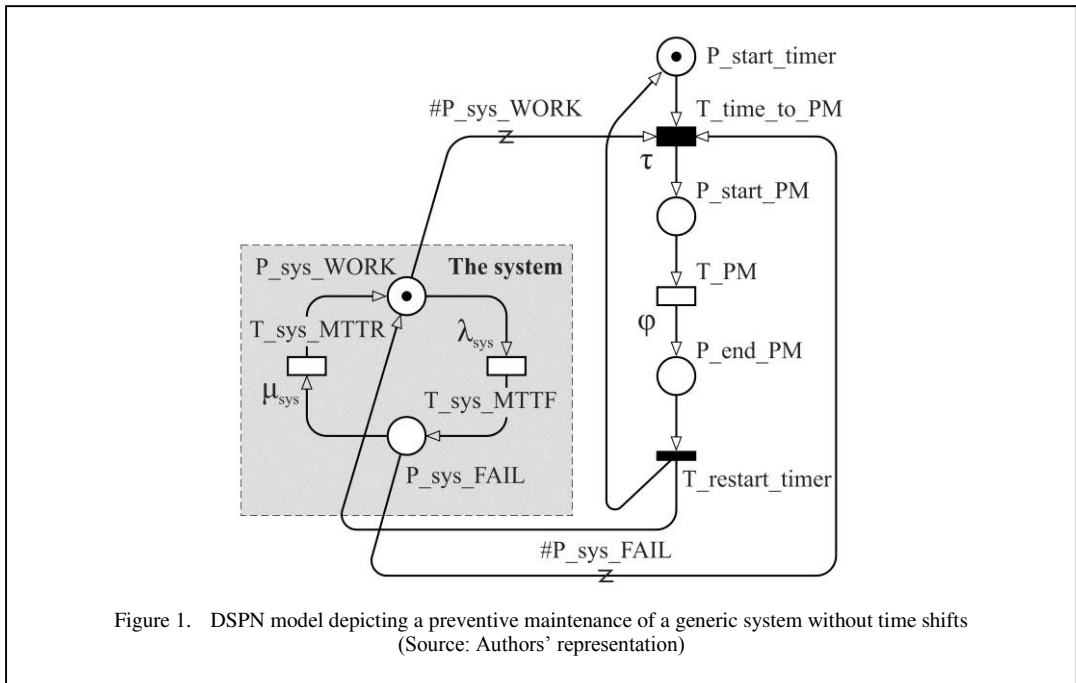

The DSPN model depicted in Fig. 1 portrays the execution of a preventive maintenance plan for a generic system without time shifts.

At time point  $t = 0$ , when the system starts functioning, the deterministic transition  $T_{time\_to\_PM}$  becomes enabled, and it fires after a fixed amount of pre-set time  $\tau$  (time to preventive maintenance), which puts a token into the place  $P_{start\_PM}$ . The preventive maintenance lasts, on average,  $1/\varphi$  time units, where  $\varphi$  is the firing rate of the exponential transition  $T_{PM}$ . When preventive maintenance ends, the firing of the immediate transition  $T_{restart\_timer}$  puts a single token into the place  $P_{sys\_WORK}$  (meaning that the system reverts to the operational mode) and also puts a single token into the place  $P_{start\_timer}$  (meaning that the next preventive maintenance is scheduled to be carried out again in  $\tau$  time units).

The DSPN model allows for the system to

undergo a preventive maintenance session while it is being repaired (a token in place  $P_{sys\_FAIL}$ ). In this particular case, the ongoing corrective maintenance is being interrupted and replaced by the preventive maintenance, since they both coincide, and it is assumed that the system is being repaired during the latter one.

Fig. 2 shows one possible evolution of the dynamics of the modeled system. The points  $t_{Fi}$  ( $i = 1, 2, \dots$ ) denote time points when a failure occurred,  $\Delta T_{Ci}$  ( $i = 1, 2, \dots$ ) are the periods of corrective maintenance, and  $t_{Pi}$  ( $i = 1, 2, \dots$ ) are time points when next preventive maintenance starts. Starting from  $t = 0$ , the time points  $t_{Pi}$  ( $i = 1, 2, \dots$ ) are always scheduled in regular time intervals with a duration of  $\tau$  time units after the termination of the previous successfully executed preventive maintenance session, no matter whether a failure has occurred previously or how many failures have happened up to the time point when a

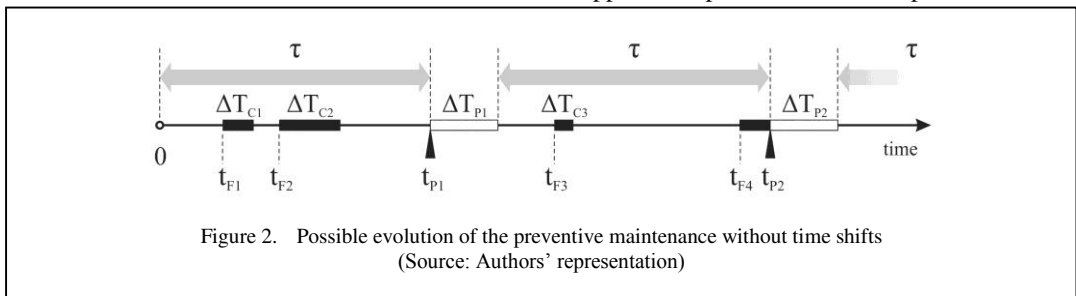

preventive maintenance session is being scheduled. Each preventive maintenance session lasts, on average,  $\Delta T_{P_i} = 1/\phi$  time units ( $i = 1, 2, \dots$ ).

**B. Preventive Maintenance with Time Shifts**

Contrary to the previous approach, this one allows for the period to the next scheduled preventive maintenance to start immediately after the finish of the last corrective maintenance, if any. In such a case, the beginning of the time to the next preventive maintenance session shifts i.e. is postponed. If no failure occurs, the maintenance plan is completely identical to the one without time shifts.

The DSPN model depicted in Fig. 3 describes the preventive maintenance of a generic system with time shifts.

In a case of a failure (a token in the place  $P_{sys\_FAIL}$ ), the ongoing time to preventive maintenance is suspended (no token in the place  $P_{start\_timer}$ ). When the corrective maintenance session ends (firing of the exponential transition  $T_{sys\_MTTR}$ ), the system becomes operational (a token in the place  $P_{sys\_WORK}$ ) and, simultaneously, the time to the next preventive maintenance session is restarted (a token in the place  $P_{start\_timer}$ ).

If no failure occurs until the beginning of the preventive maintenance session (a token in the place  $P_{start\_PM}$  after firing of the deterministic transition  $T_{time\_to\_PM}$ ), a

preventive maintenance session is being conducted that lasts, on average,  $1/\phi$  time units, where  $\phi$  is the firing rate of the exponential transition  $T_{PM}$ . After the successful conclusion of the preventive maintenance session (a token in the place  $P_{end\_PM}$  after firing of the exponential transition  $T_{PM}$ ), the firing of the enabled immediate transition  $T_{restart\_timer}$  puts a token in the place  $P_{sys\_WORK}$  (meaning that the system becomes operational again) and also puts a token in the place  $P_{start\_timer}$  (denoting the start of the period to the next preventive maintenance that will last  $\tau$  time units if not canceled by a failure).

One possible evolution of the dynamics of the modeled system is given in Fig. 4. After the first failure that occurs at the time point  $t_{F1}$ , corrective maintenance took place, which lasts for  $\Delta T_{C1}$  time units. Its end restarts the time to the first preventive maintenance session that should now start at the time point  $t_{P1}(2)$  instead at the time point  $t_{P1}(1)$ . Meanwhile, at time point  $t_{F2}$  the system suffers another failure, which takes  $\Delta T_{C2}$  time units to be resolved via a corrective maintenance session. The end of the second repairing session shifts the beginning of the period to the first preventive maintenance session again, which should now start at the time point  $t_{P1}(3)$ . After  $\tau$  time units, no failure happens, so the first preventive maintenance session can finally begin at the time point  $t_{P1}(3)$ . After the time-lapse of  $\Delta T_{P1}$  time units, it successfully concludes, so the time to the next

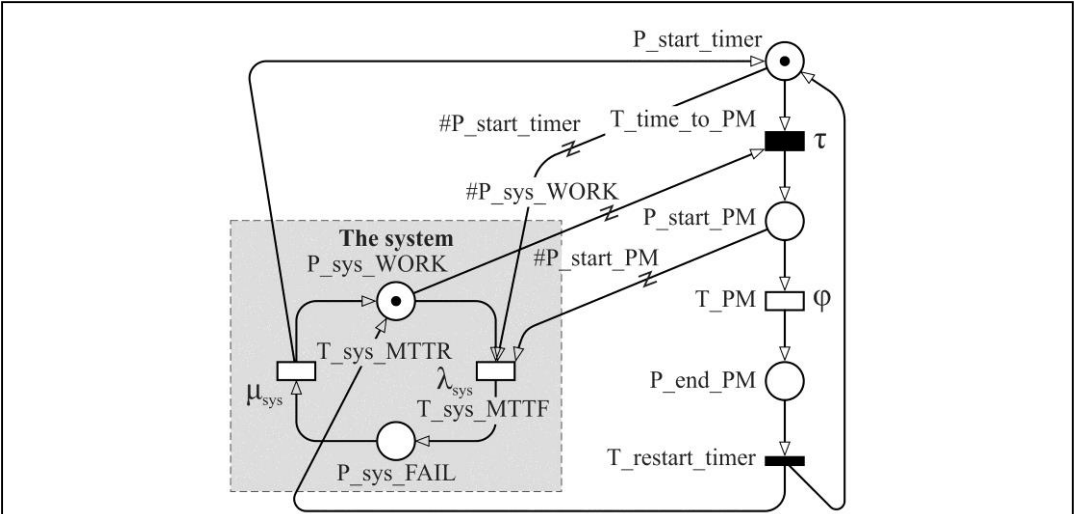
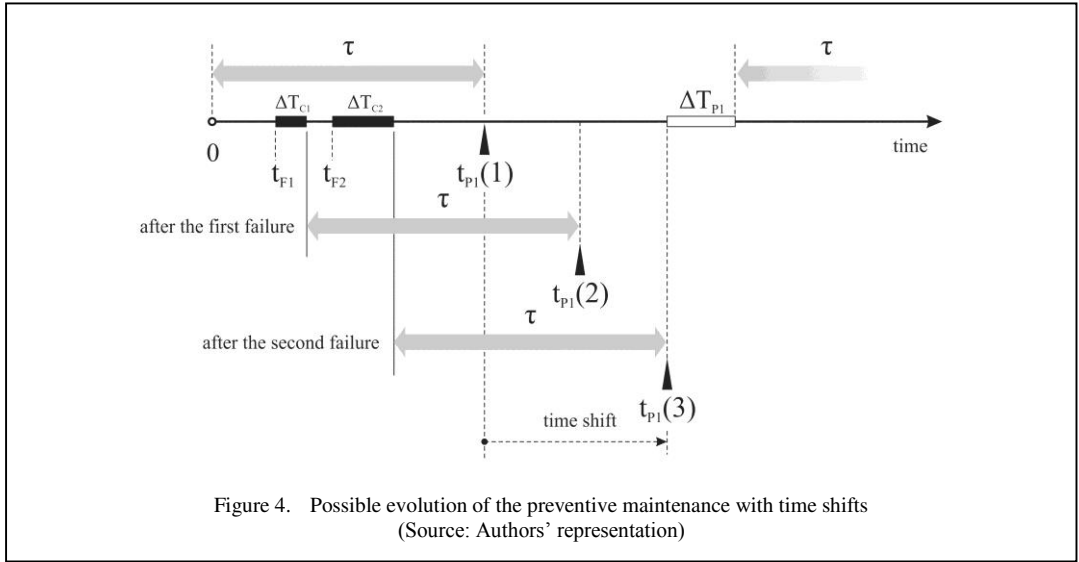

Figure 3. DSPN model depicting a preventive maintenance of a generic system with time shifts (Source: Authors' representation)



(second) preventive maintenance session has been set up. This way, the beginning of the first preventive maintenance session is postponed from time point  $t_{p1}(1)$  to  $t_{p1}(3)$ .

### C. Preventive Maintenance with Dynamic Scheduling

Dynamic scheduling refers to the possibility of either prolonging or shortening the time to the next preventive maintenance session, based on the information on whether previously a failure has occurred or not. Starting from the given initial value for the time to the next preventive maintenance session, if a failure occurs, the time until the next preventive maintenance will be shortened, otherwise, it will be prolonged. In the case of consecutive failures and/or non-failures, the continuous shortening and/or prolonging can include up to  $\pm N$  steps ( $N \geq 1$ ), starting from the initially specified time to preventive maintenance.

Fig. 5 shows a DSPN model of a system that undergoes a preventive maintenance plan with dynamic scheduling of maintenance sessions. The initial, yet default time to the first preventive maintenance is set to  $\tau_2$  time units (a token in place  $P\_start\_timer2$ ). If no failure occurs during this period, preventive maintenance is being carried out that lasts, on average,  $1/\varphi$  time units, given that  $\varphi$  is the firing rate of the exponential transition  $T\_PM$ . After the successful completion of the preventive maintenance session, the time to the next preventive maintenance progressively increases and is set to  $\tau_3$  time units (a token in place  $P\_start\_timer3$ ), where  $\tau_2 < \tau_3$ . The time to the

next preventive maintenance remains  $\tau_3$ , as soon as there are no failures. Once a failure occurs, the time to the next preventive maintenance will be gradually reduced, first to  $\tau_2$  time units (the default one), and then to  $\tau_1$  time units ( $\tau_1 < \tau_2$ ) in the case of subsequent system failures. The time to the next preventive maintenance remains  $\tau_1$ , as soon as there is a series of consequent failures. If no failure occurs, the time to the next preventive maintenance session will be prolonged first to  $\tau_2$  time units, and then again to  $\tau_3$  time units. In this particular case, the shortening/prolonging may include  $N = \pm 1$  step from the initially specified time to preventive maintenance, i.e. three different periods, however, more steps can be involved.

One possible evolution of the system dynamics, intrinsic to this particular configuration, is shown in Fig. 6, where the initial time to the first preventive maintenance session is scheduled in  $\tau_2$  time units. During this period, a failure occurs at the time point  $t_{F1}$ , and the corrective maintenance session lasts for  $\Delta T_{C1}$  time units. This, however, does not exclude the first preventive maintenance session starting at the time point  $t_{p1}$  and lasting for  $\Delta T_{p1}$  time units. When it finishes, a new preventive maintenance session is scheduled, but now in  $\tau_1$  time units ( $\tau_1 < \tau_2$ ). The second preventive maintenance session starts at the time point  $t_{p2}$  and lasts for  $\Delta T_{p2}$  time units. Since no failure occurred during this period, the beginning of the third preventive maintenance session is scheduled not in  $\tau_1$ , but in  $\tau_2$  time units. For the same reason, the fourth preventive maintenance

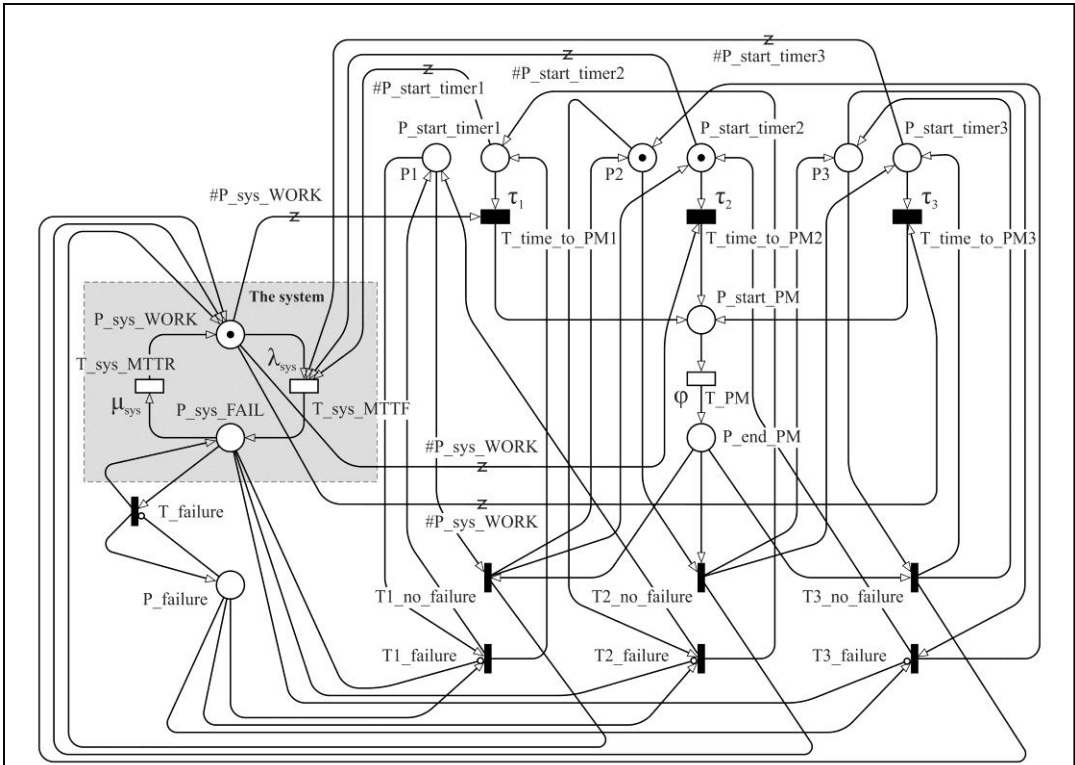

Figure 5. DSPN model depicting a preventive maintenance of a generic system with dynamic scheduling (Source: Authors' representation)

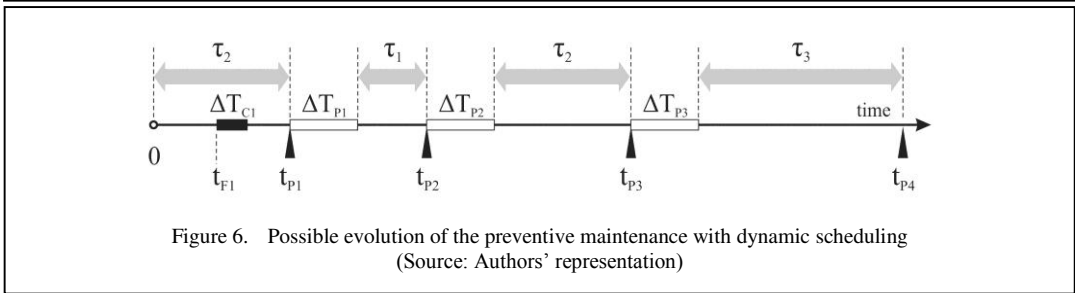

Figure 6. Possible evolution of the preventive maintenance with dynamic scheduling (Source: Authors' representation)

session is scheduled not in  $\tau_2$ , but now in  $\tau_3$  time units ( $\tau_2 < \tau_3$ ).

#### D. Predetermined Maintenance

Predetermined maintenance can be considered a special case of preventive maintenance without time shifts. It refers to the practice of simply following the system manufacturer's maintenance action plans and guidelines, including when to do inspections and maintenance operations, as opposed to a preventive maintenance plan scheduled by the maintenance team. This usually consists of a finite (i.e. preset, predetermined) number of maintenance sessions carried out in the first few years of a new asset's exploitation lifetime. The

periods between any two consecutive maintenance sessions are usually irregular; in most cases, they progressively increase.

The DSPN model portrayed in Fig. 7 resembles a system that is subject to a predetermined maintenance plan that includes three maintenance sessions, scheduled after  $\tau_1$ ,  $\tau_2$ , and  $\tau_3$  time units (in general,  $\tau_1 \neq \tau_2 \neq \tau_3$ ). These are the firing times of the deterministic transitions  $T\_time\_to\_PM_i$  ( $i = 1, 2, 3$ ). The firing of each of these transitions indicates the beginning of a preventive maintenance operation, that lasts, on average,  $1/\phi_i$  ( $i = 1, 2, 3$ ) time units, where  $\phi_i$  ( $i = 1, 2, 3$ ) are the firing rates of exponentially distributed transitions

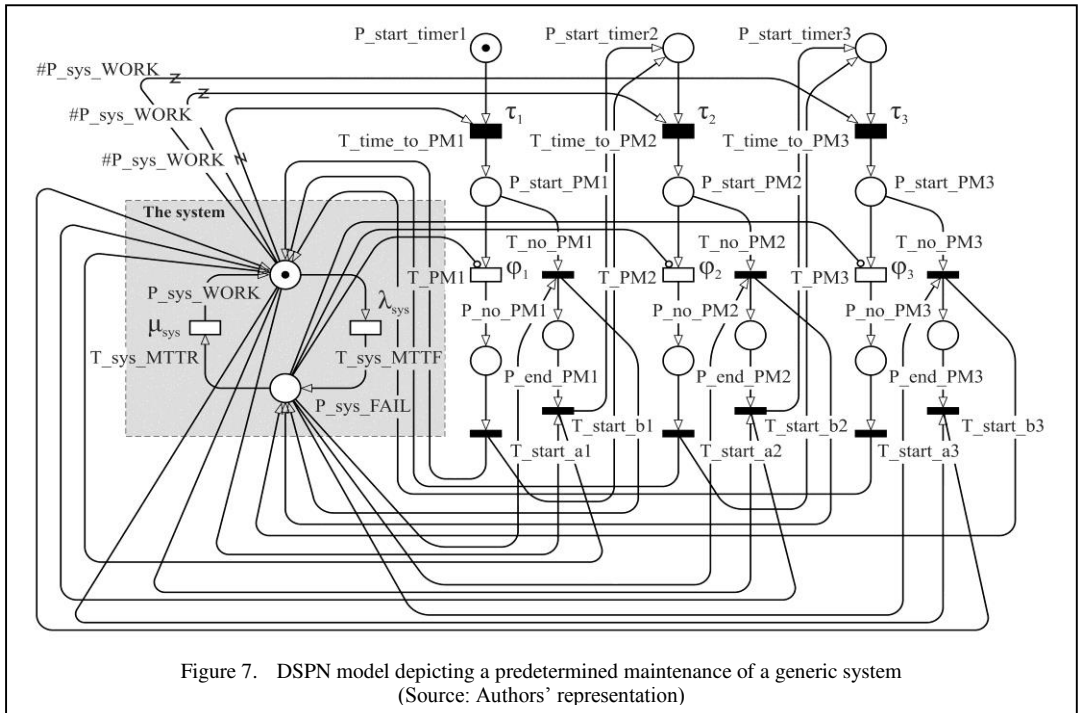

Figure 7. DSPN model depicting a predetermined maintenance of a generic system (Source: Authors' representation)

$T_{PMi}$  ( $i = 1, 2, 3$ ). Because of the different activities that need to be carried out in each preventive maintenance session, the duration of each maintenance session is set to be different, so that, in general,  $\varphi_1 \neq \varphi_2 \neq \varphi_3$ .

The successful termination of the preventive maintenance session, denoted by a token in the places  $P_{end\_PMi}$  ( $i = 1, 2, 3$ ), enables the immediate transition  $T_{start\_ai}$  ( $i = 1, 2, 3$ ), which, after firing, not only restores the working condition of the system (a token in the place  $P_{sys\_WORK}$ ) but also initiates the time lapse until the next predetermined maintenance session (a token in the place  $P_{start\_timer\_j}$ ,  $j = 2, 3$ ), that equals  $\tau_2$  and  $\tau_3$  time units, respectively.

If the predetermined time  $\tau_i$  ( $i = 1, 2, 3$ ) to the next preventive maintenance session expires during the repairing phase of the system after a failure occurs (a token in place  $P_{sys\_FAIL}$ ),

the preventive maintenance session will be omitted because of the ongoing corrective maintenance process. In this case, the immediate transition  $T_{no\_PMi}$  ( $i = 1, 2, 3$ ) becomes enabled and fires, so that a token goes to the place  $P_{no\_PMi}$  ( $i = 1, 2, 3$ ). As soon as the repair of the system concludes (by firing the exponential transition  $T_{sys\_MTTR}$ ), the immediate transition  $T_{start\_bi}$  ( $i = 1, 2, 3$ ) becomes enabled and fires, which instantly initiates the time-lapse until the next predetermined maintenance session.

After the completion of the last scheduled predetermined maintenance session, the system continues to alternate between two states: the operational one (a token in the place  $P_{sys\_WORK}$ ) and the non-operational one (a token in the place  $P_{sys\_FAIL}$ ).

Fig. 8 illustrates one possible evolution of the system's dynamics undergoing

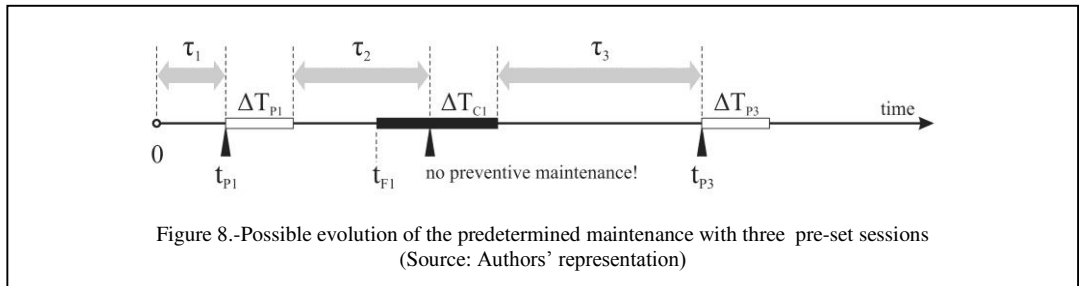

Figure 8.-Possible evolution of the predetermined maintenance with three pre-set sessions (Source: Authors' representation)

predetermined maintenance encompassing three pre-set preventive maintenance sessions.

#### IV. CONCLUSION

So far, various classes of stochastic PNs have been successfully used to model complex maintenance processes in a variety of applications due to their semantic power, huge versatility, and high applicability. The hereby presented DSPN models comprise a small subset demonstrating an efficient, powerful, flexible, yet highly intuitive approach to modeling the dynamic behavior intrinsic to various time-based maintenance strategies, applicable to a wide gamut of systems in practice. Depending on the actual system being modeled, all presented DSPN models, which are generic by nature, can be further improved and/or specialized by including additional elements and features to capture a specific behavior. However, this could increase the model's complexity and the likelihood of its computational intractability, which is an obvious drawback. On the other hand, all these models can be used for the evaluation of specific measures vis-à-vis several input parameters ( $\lambda_{\text{sys}}$ ,  $\mu_{\text{sys}}$ ,  $\phi$ ,  $\tau$ ,  $\tau_1$ ,  $\tau_2$ , etc.) to provide significant insights regarding the reliability and availability aspects of a system, as well as the efficiency and cost-effectiveness of a particular maintenance strategy.

#### REFERENCES

- [1] Yang, S. K., & Liu, T. S. (1998). A Petri Net Approach to Early Failure Detection and Isolation for Preventive Maintenance. *Quality and Reliability Engineering International* 14, 319–330.
- [2] Rochdi, Z., Driss, B., & Mohamed, T. (1999). Industrial Systems Maintenance Modelling Using Petri Nets. *Reliability Engineering and System Safety* 65, 119–124.
- [3] Simeu-Abazi, Z., & Sassine, C. (1999). Maintenance Integration in Manufacturing Systems by Using Stochastic Petri Nets. *International Journal of Production Research*, 37(17), 3927–3940.
- [4] Bondavalli, A., & Filippini, R. (2004). Modeling and Analysis of a Scheduled Maintenance System: a DSPN Approach. *The Computer Journal* 47, 634–650.
- [5] Li, S., Cai, Q., & Zhu, B. (2009). Research on Maintenance Processes Modeling. *Proceedings of the Second International Conference on Power Electronics and Intelligent Transportation Systems (PEITS 2009)*, Shenzhen, China (pp. 197–200).
- [6] Leigh, J. M., & Dunnett, S. J. (2014). Use of Petri Nets to Model the Maintenance of Wind Turbines. *Quality and Reliability Engineering International* 2016, 32, 167–180.
- [7] Santos, F. P., Teixeira, Â. P., & Guedes Soares, C. (2019). Modeling, Simulation and Optimization of Maintenance Cost Aspects on Multiunit Systems by Stochastic Petri Nets with Predicates. *Simulation: Transactions of the Society for Modeling and Simulation International*, 95(5), 461–478.
- [8] Bahl, A., Singh, S., Mann, G. S., & Singh, J. (2019). Maintenance Modelling Using Petri Nets. *Journal of Emerging Technologies and Innovative Research*, 6(1), 1825–1829.
- [9] Song, H., & Schnieder, E. (2018). Modeling of Railway System Maintenance and Availability by Means of Colored Petri Nets. *Maintenance and Reliability (Eksploracja i Niezawodnosc)*, 20(2), 236–243.
- [10] Sheng, J., & Prescott, D. (2019). A Coloured Petri Net Framework for Modelling Aircraft Fleet Maintenance. *Reliability Engineering and System Safety* 189, 67–88.
- [11] Orlov, S. P., Susarev, S. V., & Uchaikin, R. A. (2021). Application of Hierarchical Colored Petri Nets for Technological Facilities' Maintenance Process Evaluation. *Applied Sciences* 11, 5100, 1–26.
- [12] Lee, J., & Mitici, M. (2021). Predictive Aircraft Maintenance: Modeling and Analysis Using Stochastic Petri Nets. In Castanier, B., Cepin, M., Bigaud, D., & Berenguer, C. (Eds.), *Proceedings of the 31st European Safety and Reliability Conference (ESREL 2021)*, Angers, France (pp. 146–153).
- [13] Ferreira, C., Neves, L. C., Silva, A., & de Brito, J. (2020). Stochastic Maintenance Models for Ceramic Claddings. *Structure and Infrastructure Engineering*, 16(2), 247–265.
- [14] Pinto, C. A., Farinha, J. T., & Singh, S. (2021). Contributions of Petri Nets to the Reliability and Availability of an Electrical Power System in a Big European Hospital - A Case Study. *WSEAS Transactions on Systems and Control* 16, 21–42.
- [15] Melani, A. H. d. A., Michalski, M. A. d. C., Murad, C. A., Caminada Netto, A., & de Souza, G. F. M. (2022). Generalized Stochastic Petri Nets for Planning and Optimizing Maintenance Logistics of Small Hydroelectric Power Plants. *Energies* 15, 2742, 1–16.
- [16] Chiachío, M., Saleh, A., Naybour, S., Chiachío, J., & Andrews, J. (2022). Reduction of Petri Net Maintenance Modeling Complexity via Approximate Bayesian Computation. *Reliability Engineering and System Safety* 222, 108365, 1–16.
- [17] Hristoski, I., & Dimovski, T. (2022). An Overview of Maintenance Strategies Using Petri Net Models. Unpublished manuscript.
- [18] Ciardo, G., & Lindemann, C. (1993). Analysis of deterministic and stochastic Petri nets, In *Proceedings of the 5th International Workshop on Petri Nets and Performance Models*, Toulouse, France (pp. 160–169).
- [19] Lindemann, C. (1998). *Performance Modelling with Deterministic and Stochastic Petri Nets*. Wiley, New York, USA.

# Basel 3.1 – New Regulatory Framework for Banks

Vesna Martin<sup>1</sup>

<sup>1</sup>\*Economists Association of Belgrade, Kneza Miloša 10, 11000 Belgrade, Serbia

<sup>1</sup>martinv0803@hotmail.com

**Abstract**—A stable, liquid, and profitable banking system is required for any country to achieve economic growth and development. Comprehensive regulation is required to achieve and maintain the banking sector's stability and resilience, which is especially important during times of crisis. The Basel Committee on Banking Supervision publishes recommendations for global banking regulation and supervision in the form of the Basel Accord. The development of the aforementioned standards aims to strengthen the banking system's resilience and increase its capitalization. Basel I was adopted in 1988, and Basel II was adopted in June 2006 to improve it. The global economic crisis exposed flaws in financial system regulation, prompting the Basel Committee on Banking Supervision to present Basel III in December 2010. The introduction of Basel 3.1, which refers to the new standard for operational, market and credit risk, as well as credit valuation adjustment, was expected to improve the regulation even further. Because of the coronavirus, its implementation has been pushed back to January 1, 2025.

**Keywords** - banking regulation, Basel Committee, capital requirements, banking system

## I. INTRODUCTION

The Basel Accord is a set of recommendations for banking regulation. The Basel Accords are named after the Basel Committee on Banking Supervision, which has its secretariat at the Bank for International Settlements in Basel, Switzerland, and where the committee usually meets. Basel I was the first international agreement on bank capital published in 1988 in response to the reduction of

the capital bases of the world's largest banks. Such movements are a result of the increasing volatility in financial markets, current globalization, and the deregulation that was prevalent in the 1970s and 1980s. After overcoming the shortcomings of Basel I, the Basel Committee on Banking Supervision actively worked on the publication of an improved regulatory framework for improving the stability of the international banking system, publishing a revised framework in June 2004, with additional guidelines included in the version published in June 2006 (changes related to market risks as well as the treatment of trading activities). The Basel Committee on Banking Supervision began the process of amending these standards in response to the observed shortcomings of Basel II, as well as the current weakness of the financial system, which was most visible during the global economic crisis. The Committee published a set of documents related to the presentation of the new standard-Basel III-in December 2010, and the new documents refer to capital adequacy and the introduction of minimum requirements for banks' liquidity issues for the first time. The Committee published a preliminary assessment of the effectiveness of the Basel Accord reforms during the coronavirus pandemic in early July 2021. Because of the pandemic, the final Basel 3.1 reforms have been delayed by a year, to January 1, 2023. The European Commission announced an additional postponement of implementation (January 1, 2025), with the implementation of transitional arrangements that will apply for the next five years.

---

\*The views expressed in this paper are those of the author, and do not necessarily represent the official view of the Economists Association of Belgrade.



The paper is structured as follows. There are four sections in addition to the introduction and conclusion. The second section of this paper will present the main innovations of Basel 3.1 as well as the time frame for their implementation, while the third section will provide an overview of central banks' and regulators' activities related to the implementation of Basel 3.1. The fourth section of the paper focuses on the impact of Basel 3.1 on risk management, while the fifth is analyzing implementation of Basel agreements in Serbia's banking system.

**II. MAIN INNOVATIONS OF BASEL 3.1**

The Basel Committee on Banking Supervision issued a report in July 2021 that provided an overview of the impact of the Basel reforms implemented in light of the coronavirus pandemic. According to the report, the increase in quality and higher levels of capital and liquidity in the banking system contributed to banks being able to cope more easily with the impact of COVID-19 during the pandemic, indicating that the Basel reforms have achieved their main goal, which is to strengthen the banking system's resilience [1]. Basel 3.1 (also known as Basel 4 in some documents) represents the process of finalizing the Basel 3 standard, which began almost a decade ago.

The Group of Central Bank Governors and Heads of Supervision (GHOS), the supervisory body for the Basel Committee on Banking Supervision, has endorsed Basel III's pending post-crisis regulatory reforms. Mario Draghi, then-Chairman of the Group of Central Bank Governors and Heads of Supervision, stated in December 2017 that the start of the Basel III reform represents a major regulatory milestone that will increase confidence in the banking sector. The adoption of the Basel III reform package will complete global regulatory reform, which began following the global economic crisis. The implementation of Basel 3.1 necessitates the following changes: (1) revision of the standardized approach to credit risk, which will contribute to improving the existing approach's risk response; (2) a review of the internal rating model approach to credit risk, with a restriction on the use of advanced internal model approaches for low default portfolios; (3) revision of the credit value adjustment framework, including the elimination of the internal model approach and the implementation of a revised standardized approach; (4) revision of the standardized approach for operational risk,

TABLE I. IMPLEMENTATION DATES OF BASEL 3.1 [3].

Revision	Implementation date
Standardised approach for credit risk	1 January 2022
Internal ratings-based framework	1 January 2022
Credit valuation adjustment framework	1 January 2022
Operational risk framework	1 January 2022
Leverage ratio	Existing exposure definition: 1 January 2018
	Revised exposure definition: 1 January 2022
	G-SIB buffer: 1 January 2022
Output floor	1 January 2022: 50%
	1 January 2023: 55%
	1 January 2024: 60%
	1 January 2025: 65%
	1 January 2026: 70%
	1 January 2027: 72.5%

which will be replaced by the existing standardized approach and advanced measurement approach; (5) revision of the method of measuring leverage ratios and leverage ratios for global systemically important banks (G-SIBs); and (6) setting an aggregate output floor that will allow risk-weighted assets calculated on the basis of internal models to no longer be less than 72.5% of risk-weighted assets, which was calculated previously in accordance with Basel III. Banks must also use a standardized approach to disclose the value of their risk-weighted assets. The initial implementation of the aforementioned reforms was planned for 2019, but due to the coronavirus pandemic most changes are pushed back to January 1, 2025. It is necessary to implement and apply the regulatory reports for the revised Basel agreement by the aforementioned deadline [2]. The Basel Committee on Banking Supervision has planned a transition period for the implementation of the aforementioned changes to ensure timely implementation by competent authorities and bank adaptation. Table I shows the most important dates for Basel 3.1 implementation [3].

**III. CENTRAL BANKS' AND REGULATORS' ACTIVITIES RELATED TO THE IMPLEMENTATION OF BASEL 3.1**

To implement Basel 3.1, regulatory changes were proposed in the European Union, the United Kingdom, and the United States of America. The European Commission adopted the Capital Requirements Regulation (CRR) and the Capital

Requirements Directive (CRD IV) in the European Union at the end of October 2021 [4]. The goal of the aforementioned regulation is to make European Union banks even more resistant to potential economic shocks, while also contributing to the economic recovery from the effects of the coronavirus pandemic, as well as the banking sector's effort to achieve a green transition. The adopted regulations amend European Union Regulation 575/2013, which relates to prudential requirements for credit institutions and investment firms [5], as well as the amendment Directive 2013/36/EU [6], which relates to capital requirements. The European Banking Authority (EBA) published at the end of September 2022 a report on the impact of full implementation of Basel 3.1 on European Union banks in 2028. The report, which employs the same methodology as the Basel Committee on Banking Supervision in its assessment, concludes that full implementation of Basel 3.1 will result in a 15% increase in the current Tier 1 minimum required capital for European Union banks. Banks will require an additional 1.2 billion euros in Tier 1 capital to adapt their operations to the new regulations [7].

The Prudential Regulation Authority (PRA) is a division of the Bank of England that oversees and regulates the activities of approximately 1,500 banks, credit unions, insurance companies, and investment firms. The Prudential Regulation Authority issued two announcements in July and October 2021 regarding the implementation of Basel 3.1 in the United Kingdom. The actual implementation of Basel 3.1 in the United Kingdom is uncertain for several reasons, including an international agreement to postpone implementation due to COVID-19, the need to respond to other regulatory challenges, and the implementation of new processes that the Prudential Regulation Authority must develop in order to incorporate the new Basel standard into the United Kingdom's legislative framework. A consultation paper on Basel 3.1 is expected to be published in the fourth quarter of 2022, with implementation beginning on January 1, 2025 [8].

A Notice of Proposed Rulemaking (NPR) is an official document that announces and publishes a specific plan to solve problems or achieve goals within the United States of America's regulatory authorities. All proposed regulations must be published in the Federal Register to inform the public and provide an opportunity for them to submit comments. The

Federal Reserve System has yet to issue a Notice of Proposed Rulemaking announcing Basel 3.1 implementation. According to Ernst & Young's analysis, despite the lack of publication of the regulation, well-informed participants anticipate that the American version of Basel 3.1 will completely abandon the use of internal capital models, particularly those related to credit risk and counterparty risk. This will exacerbate the already significant differences in regulation between the United States and other major financial centers [9].

The implementation of Basel 3.1 and the work of the Basel Committee on Banking Supervision received significant support from prudential regulators and the central banks of the European Union and the United Kingdom. In April 2020, His Majesty's Treasury (HM Treasury) and the Prudential Regulation Authority welcomed the postponement of Basel 3.1 implementation, which is critical for providing banks and supervisors with the operational capacity to respond to the pandemic's challenges [10]. Jose Manuel Campa, Chairperson of the European Banking Authority, Luis de Guindos, Vice President of the European Central Bank, and Andrea Enria, Chairperson of the European Central Bank's Supervisory Board, wrote to Mairead McGuinness, Commissioner for Financial Stability, Financial Services, and Capital Markets Union in the European Commission, in early September 2021. The letter's signatories stated that the European Banking Authority and the European Central Bank demonstrate their commitment to the timely implementation of Basel agreement reforms in the European Union's banking system. Furthermore, it was stated that the European Union's banking system demonstrated the ability to contribute to economic resilience even during the pandemic, owing to the high-quality regulatory framework [11].

#### IV. THE IMPACT OF BASEL 3.1 ON RISK MANAGEMENT

The implementation of Basel 3.1 standards in the banking sector means an increase in capital requirements, as well as liquidity and leverage requirements. The global economic crisis of 2007/2008 highlighted the need for a better definition of risk-weighted capital ratios and capital adequacy because a reduction in the aforementioned indicators would call financial stability into question. In the event of a crisis, the banking system would be unable to make loans

to the corporates and households, increasing rather than amortizing economic shocks. Basel 3.1 aimed to improve the credibility of risk-weighted capital ratio calculations by applying greater robustness to the calculation of risk (primarily credit, market, and operational risk) through the use of a standardized approach as well as an internal model. Furthermore, the effort of this banking standard is to ensure that banks have greater capitalization in relation to the level of business risk present, higher capital quality in relation to the losses that it may need to cover, and improved accuracy in the calculation and measurement of bank business risk.

Basel 3.1, with its new method of calculating risk-weighted assets, aims to make that calculation more consistent and resilient across all banks. This requirement was met by introducing more detailed requirements that better reflect the overall exposure risk and thus represent an alternative method of risk assessment using the standardized approach. When it relates to evaluating risk using the internal rating model, the Basel 3.1 proposal refers to a reduction in modeling flexibility as well as the introduction of restrictions on certain model inputs. This improves the consistency of the calculation when using the internal rating model. In addition to the foregoing, Basel 3.1 introduces an output floor (see Table I), which will be phased in from January 1, 2022 (when the output floor is 50%) to January 1, 2027 (when the output floor is 72.5%). This approach is based on the goal of providing a straightforward and consistent method for calculating risk weights during the standard's phased implementation.

The primary advantages of introducing Basel 3.1 are related to the implementation of regulations that seek to reduce the likelihood of future financial crises by implementing: (1) detailed requirements for measuring risk-weighted assets, which promote consistency and simplicity of calculation; and (2) increased sensitivity to risk through the application of a standardized approach to capital calculation. This approach will result in risk-weighted assets expressing banks' exposure to risk using a standardized approach; (3) limiting the use of internal models in risk assessment and in cases where risk-weighted assets cannot be determined in a prudent and adequate manner, preventing oscillations in risk-weighted asset measurement; and (4) the implementation of the output floor ensures that the level of risk-weighted assets calculated using the internal model does not fall

below the level obtained by calculating using the standardized approach. This would avoid excessive oscillation and cyclicity in risk-weighted asset movement. Based on the foregoing, we can conclude that full implementation of the Basel 3.1 standard will contribute to the complete utilization of the benefits of the post-global economic crisis reform package, which will further contribute to the continued safe operation of banks while ensuring a higher quality of their capital.

#### V. IMPLEMENTATION OF BASEL AGREEMENTS IN SERBIA'S BANKING SYSTEM

Basel I was published in 1988 by the Basel Committee on Banking Supervision in order to establish a unique method of calculating capital and, overall, to strengthen the financial system's stability. The basic and supplementary elements of capital were defined with the introduction of Basel I, followed by the weights (risk weights: 0%, 20%, 50%, and 100%) required to calculate credit risk per balance sheet asset and credit conversion factors for off-balance-sheet items, as well as relationships between capital and total balance and off-balance-sheet exposures of the bank weighted by credit risk, with the goal of calculating capital adequacy indicators. According to the calculations presented (1), the bank's capital adequacy indicator should be at least 8%.

$$\frac{\text{Capital}}{\text{Credit risk weighted exposure}} \geq 8\% \quad (1)$$

Basel I's introduction highlighted both its strengths and weaknesses. In terms of benefits, the implementation of Basel I contributed to an increase in capital adequacy in the banking sector. This standard was implemented in various countries around the world, which contributed to increased global banking competition and discipline in the capital management process. Among the shortcomings of Basel I, it is frequently stated that only credit risk was considered during the capital adequacy analysis, while other risks (such as market and operational risk) were not. As a result, when assessing credit risk, no distinction was made between borrowers of varying quality and rating. In addition to the foregoing, Basel I has flaws in that the scope of the regulation does not adequately account for the risk and effect of using modern financial instruments, and the emphasis is on the book

value rather than the market value. The shortcomings of Basel I concerning market risk were eliminated on the basis of amendments from 1993 and 1996, and then the capital requirement for market risk and a new instrument for assessing the bank's market risk, Value at Risk (VAR) (2), were introduced. RWE stands for Risk-weighted exposure [12].

$$\frac{\text{Capital}}{\text{RWE}(\text{credit and market risk})} \geq 8\% \cdot (2)$$

Based on the deficiencies and their correction, the Basel Committee on Banking Supervision published Basel II in June 2006, which represents the continuation of international efforts to improve the stability of the banking system. Basel II is built on three pillars. *The first pillar* is the establishment of minimum capital requirements for credit, market, and operational risk. The first pillar's most significant innovations concern the treatment of credit risk and the implementation of a capital requirement for operational risk. Basel II allows banks to use a more sophisticated approach to calculating capital risk for credit risk that takes into account the unique characteristics of each individual bank. Then, in Basel II, a new capital requirement for operational risk is introduced, as a risk related to losses caused by employee failures, the occurrence of unpredictable external events, insufficient procedures in bank operations, and insufficient management of information and other systems in the bank. The first pillar of Basel II in Serbia's banking system is based on the Decision on Bank Capital Adequacy. *The second pillar* of Basel II is based on the implementation of a new approach to risk management and bank capital adequacy assessment. As a result, banks must assess the adequacy of capital to cover all risks associated with their operations. In doing so, the supervisor should determine whether a specific bank has sufficient capital in relation to its exposure to business risks. The second pillar of Basel II is based on four principles: (1) supervision; (2) internal capital adequacy assessment; (3) capital above the minimum level defined by the first pillar; and (4) supervisor intervention to prevent capital from falling below the minimum level. *The third pillar* of Basel II refers to the enhancement of market discipline, as evidenced by the publication of relevant data. This provides key information to other market participants about capital, risk exposure, risk management

processes, and capital adequacy. The implementation of this pillar increases the security and stability of the banking sector as well as the entire financial system. In Serbia, the third pillar of Basel II is implemented based on the Decision on data and information disclosure by banks [13].

The global financial crisis 2007/2008 reaffirmed the importance of effective banking supervision in ensuring full implementation of prudential policies, avoiding moral hazard posed by "too big to fail" institutions, and improving risk management practices and appropriate disclosure. The financial crisis exposed numerous flaws in corporate governance, risk management, delineation of duties and responsibilities, and other areas. Basel III was designed to strengthen and harmonize global banking capital and liquidity standards. Capital buffers are one of the key innovations of the Basel III standard, representing an additional Common Equity Tier 1 (CET 1) capital that banks must maintain above the regulatory minimum. Capital buffers should limit systemic risks in the financial system, which can be structural (systemic risk buffer and capital buffer for a systemically important bank) or cyclical (systemic risk buffer and capital buffer for a systemically important bank) (capital conservation buffer and countercyclical capital buffer) [14]. Since June 30, 2017, Serbian banks have been required to maintain the following capital buffers [15]:

- (1) *Capital conservation buffer* - According to the Decision on Capital Adequacy of Banks of 15 December 2016, a bank is required to maintain a capital conservation buffer equal to 2.5% of its risk-weighted assets on an individual and consolidated basis. Only Common Equity Tier 1 capital may be used in the capital conservation buffer.
- (2) *Countercyclical capital buffer* - The rate is set at 0% in the Decision on the Countercyclical Buffer Rate for the Republic of Serbia of 8 June 2017, which is effective as of 30 June 2017. The NBS Executive Board decided on September 8, 2022, to keep the Republic of Serbia's countercyclical capital buffer (CCyB) rate at 0%, citing the following: CCyB guideline: 0%; credit-to-GDP ratio: 83.5%; and credit-to-GDP ratio deviation from long-term trend (credit-

to-GDP gap): -0.002 pp. The Executive Board of the National Bank of Serbia makes the quarterly decision to keep or change the CCyB rate in the Republic of Serbia [16].

- (3) *Capital buffer for a systemically important bank* - On June 16, 2022, the Decision on Establishing a List of Systemically Important Banks in the Republic of Serbia and Capital Buffer Rates for Those Banks establishes systemically important banks, and the capital buffer rates that those banks must maintain as of June 30, 2022. Five banks are required to maintain a 2% capital buffer, while four banks must maintain a 1% buffer.
- (4) *Systemic risk buffer* - The systemic risk buffer rate is 3% of total foreign currency and foreign currency-indexed placements of a bank in the Republic of Serbia approved for corporates and households. All banks must maintain the systemic risk buffer if their share of foreign currency and foreign currency-indexed placements approved to corporates and households in the Republic of Serbia exceeds 10% of total placements approved to corporates and households in the Republic of Serbia.

The implementation of Basel standards in the Republic of Serbia's banking sector contributed to increasing the stability and liquidity of their operations, thereby contributing to the preservation, and strengthening of financial stability. Further improving the function of financial stability, both in Serbia and globally, necessitates a wide range of policies, including prudential, macroeconomic, monetary, and fiscal policies.

## VI. CONCLUSION

The Basel Accords represent the Basel Committee on Banking Supervision's recommendations for banking regulations. Basel I was established in 1988 with the goal of establishing capital requirements that addressed credit risk. Basel II was adopted in June 2006 as a result of shortcomings in the implementation of Basel I, and it is based on three pillars: minimum capital requirements for credit, market, and operational risk; implementation of a new approach to risk management and bank capital adequacy assessment; and market discipline.

Following that, in response to the global financial crisis of 2007/2008, the Basel Committee on Banking Supervision adopted a new standard, Basel III, in December 2010 that refers to capital adequacy, and with this standard, minimum liquidity requirements for banks were introduced.

The Basel Committee on Banking Supervision is actively working on improving Basel III, which refers to Basel 3.1 and represents a new standard for operational and credit risk as well as credit valuation adjustment. The goal of implementing Basel 3.1 is to further improve banking sector regulation. Basel 3.1 implementation has been delayed until January 1, 2025, due to the coronavirus pandemic. The implementation of this standard entails revising the standardized approach for credit risk, then revising internal credit risk models, revising the standardized approach for measuring operational risk, and revising methods for measuring leverage ratios. The European Union, the United Kingdom, and the United States of America have all proposed changes to Basel 3.1. The Capital Requirements Regulation (CRR) and the Capital Requirements Directive (CRD IV) were adopted at the European Union level at the end of October 2021 with the goal of strengthening the resilience of the banking system. Furthermore, the goal is to contribute to the economic recovery from the coronavirus pandemic, as well as the effort to achieve a green transition. The European Central Bank and the Bank of England, as well as other regulators, support the implementation of Basel 3.1 (the European Banking Authority and the European Commission). To preserve and strengthen financial stability, the National Bank of Serbia has actively worked and continues to work on improving the regulatory framework for the banking sector. The implementation of Basel agreements into the domestic financial system resulted in banking sector stability and adequate capitalization.

The new capital standards represent an effort to build a banking system that is highly resistant to external and internal challenges in its operations and that can rehabilitate potential costs from exposure to numerous shocks on the basis of adequate capitalization. In the event of systemic risk, banks can release previously built capital requirements and absorb losses while continuing to provide critical financial services. In this way, the Basel standards represent a global financial reform that ensures long-term financial stability and resistance to stress periods.

## REFERENCES

- [1] Early lessons from the Covid-19 pandemic on the Basel reforms, Basel Committee on Banking Supervision. July 2021. <https://www.bis.org/bcb/publ/d521.htm> (Accessed on: 17.10.2022.)
- [2] Governors and Heads of Supervision finalise Basel III reforms. December 2017. <https://www.bis.org/press/p171207.htm> (Accessed on: 17.10.2022.)
- [3] Basel III: Finalising post-crisis reforms, Basel Committee on Banking Supervision. December 2017. <https://www.bis.org/bcb/publ/d424.htm>(Accessed on: 17.10.2022.)
- [4] Regulation of the European Parliament and of the Council Amending Regulation (EU) No 575/2013 as regards requirements for credit risk, credit valuation adjustment risk, operational risk, market risk and the output floor. October 2021. <https://eur-lex.europa.eu/legal-content/EN/TXT/?uri=celex%3A52021PC0664> (Accessed on: 18.10.2022.)
- [5] Regulation (EU) No 575/2013 of the European Parliament and of the Council of 26 June 2013 on prudential requirements for credit institutions and investment firms and amending Regulation (EU) No 648/2012. June 2013. <https://eur-lex.europa.eu/legal-content/EN/TXT/?uri=celex%3A32013R0575> (Accessed on: 18.10.2022.)
- [6] Directive 2013/36/EU of the European Parliament and of the Council of 26 June 2013 on access to the activity of credit institutions and the prudential supervision of credit institutions and investment firms, amending Directive 2002/87/EC and repealing Directives 2006/48/EC and 2006/49/EC. July 2013. <https://eur-lex.europa.eu/legal-content/EN/TXT/?uri=celex%3A32013L0036> (Accessed on: 18.10.2022.)
- [7] The EBA publishes its Report on the first mandatory exercise on Basel III full implementation impact, <https://www.eba.europa.eu/eba-publishes-its-report-first-mandatory-exercise-basel-iii-full-implementation-impact> (Accessed on: 18.10.2022.)
- [8] Implementation of Basel standards, <https://www.bankofengland.co.uk/news/2022/march/implementation-of-basel-standards> (Accessed on: 18.10.2022.)
- [9] Why global regulatory standards are fragmenting as Basel 4 is implemented. [https://www.ey.com/en\\_sa/banking-capital-markets-risk-regulatory-transformation/why-global-regulatory-standards-are-fragmenting-as-basel-4-is-implemented](https://www.ey.com/en_sa/banking-capital-markets-risk-regulatory-transformation/why-global-regulatory-standards-are-fragmenting-as-basel-4-is-implemented) (Accessed on: 18.10.2022.)
- [10] Joint PRA and HMT statement on the delay to implementation of the Basel 3.1 standards. <https://www.bankofengland.co.uk/prudential-regulation/publication/2020/joint-pra-and-hmt-statement-on-the-delay-to-implementation-of-the-basel-3-1-standards> (Accessed on: 18.10.2022.)
- [11] EU implementation of outstanding Basel III reforms, [https://www.bankingsupervision.europa.eu/ecb/pub/pdf/ssm.ECB-EBA\\_letter\\_on\\_B3\\_implementation~88fdb33210.en.pdf](https://www.bankingsupervision.europa.eu/ecb/pub/pdf/ssm.ECB-EBA_letter_on_B3_implementation~88fdb33210.en.pdf) (Accessed on: 18.10.2022.)
- [12] Basel I, <https://nbs.rs/en/finansijske-institucije/banke/bazelski-stendardi/bazel-I/index.html> (Accessed on: 21.10.2022.)
- [13] Basel II, <https://nbs.rs/en/finansijske-institucije/banke/bazelski-stendardi/bazel-II>(Accessed on: 21.10.2022.)
- [14] Martin, V. (2021). Analysis of capital buffers in Serbia. *The Annals of the Faculty of Economics in Subotica*, 57 (46), 73-87
- [15] Capital buffers, [https://nbs.rs/en/ciljevi-i-funkcije/finansijska-stabilnost/zastitni-slojevi\\_kapitala/](https://nbs.rs/en/ciljevi-i-funkcije/finansijska-stabilnost/zastitni-slojevi_kapitala/) (Accessed on: 21.10.2022.)
- [16] Martin, V. (2022). Countercyclical Capital Buffer Analysis in Serbia. *Ekonomski vidici, Society of economists Belgrade*, 1-2, 1-21



# Research and Development of Human Resource Management in Serbian Organizations

Tijana Krušković<sup>1</sup>, Biljana Ilić<sup>2</sup>, Slavica Anđelić<sup>3</sup>

<sup>1,2</sup>Faculty of Management, Zaječar, Serbia

<sup>3</sup>Modern Business School, Belgrade, Serbia

<sup>1</sup>tijanakruskovic@gmail.com, <sup>2</sup>biljana.ilic@fmz.edu.rs, <sup>3</sup>slavicaandjel@gmail.com

**Abstract**—For the past few years, especially during and after the COVID-19 pandemic, business organizations were affected strongly, so they were forced to adapt to market trends to survive changes or even to excel in their results and outcomes. Human resource's function can have an active role in achieving business results, and companies should shape human resource departments in that way. Depending on the development stage of the HR function in the organization, companies can win or fail in the labor market. Companies that were able to become flexible in unpredictable times, gained a lot of benefits through retaining employees, selecting talents, reducing costs, and shaping their organizational culture in the desired direction. There are still a lot of questions about what the future of HR will look like, and this paper will present the latest trends and predictions for years to come.

**Keywords** - HR function, trends, predictions

## I. INTRODUCTION

The human resources management task is to identify and use all the potential that the employees in the organization possess, all with the aim of achieving the desired results. As human resources have several specificities in relation to other resources in the organization, their role in achieving organizational goals is very specific and of particular importance. As such, it is one of its key functions of it. It means that the experience in personnel management is mirrored in business success [1]. The importance of HR in the decision-making process has not always been understood. Due to the pandemic,

there have been numerous changes in the labor market. What the pandemic has not changed is that employees, wherever they work, want to feel a sense of belonging to the organization and to feel part of the team. Close cooperation with colleagues is very important even if the work is done remotely. Employees want prompt feedback and to know that their work is adding value.

## II. HR RESEARCH AND DEVELOPMENT

Human resource management is the process of acquiring, training, appraising, and compensating employees, and of attending to their labor relations, health and safety, and fairness concern [2]. Human resource management is more complex today than it was in the past due to the changes in the external environment that organizations face [3].

HR management is the effective management of people at work. Also, it is the function performed in organizations that facilitates the most effective use of people (employees) to achieve organizational and individual goals. According to this definition, HRM is a function that is performed in the organization, and it facilitates the most effective use of employees. The use of employees is done to achieve organizational goals as well as individual goals [4].

Mathis and Jackson (2011) in their textbook titled Human Resource Management presents a definition of HRM that is: HRM is designing management systems to ensure that human talent is used effectively and efficiently to accomplish



**Nine imperatives can help HR leaders ready their organizations for the future.**

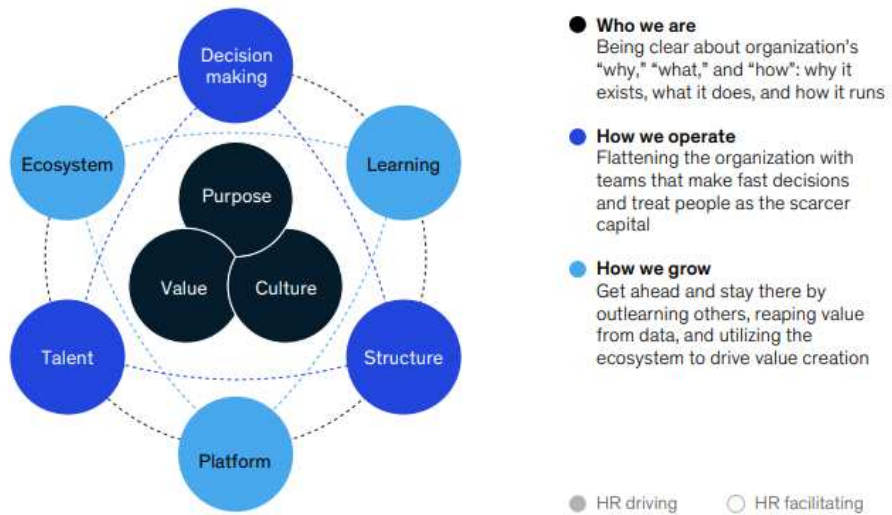

Figure 1. McKinsey [6].

organizational goals. In the definition management systems mean HRM systems with regard to HR functions. This definition stresses that human talent is to be used in a way that is effective and in the way that is efficient. Also, here the word human talent means valuable employees [4].

Human resource management is the process of acquiring, training, appraising, and compensating employees, and of attending to labor relations, health and safety, and fairness concern [2].

In terms of overall human resource management, there is a shared opinion that development is part of the strategic approach to HRM, a recognition that HRM work is important and should be embraced by all managers in the organization [5].

Strategic human resource management means formulating and executing human resource policies and practices that produce the employee competencies and behaviors the company needs to achieve its strategic aims [2].

McKinsey [6] brings the study about possibilities on how businesses can best organize for the future and suggest that future-ready companies share three characteristics. They know what they are and what they stand for; they operate with a fixation on speed and simplicity, and they grow by scaling up their ability to learn and innovate. The Human Resource department

can help propel this transformation by facilitating positive change in these three key areas, as well as with nine imperatives that radiate out from them.

Organizational culture is the sum of all the values and beliefs that are shared throughout the entire organization. Managers should be aware of the importance of organizational culture, as a guiding set of behaviors, since affects everyone, whether they're internal or external to the organization. In terms of COVID-19, all industries were affected strongly, as a society also. People will feel safer and more secure if they know that their organizations stand out in comparison to other employers. The best way to stand out is to have clear organizational culture, purpose, and defined values.

In every business organization, HR function has its own growth path and development stage. In that sense, managers should identify the stage in which their HR function is and the steps they need to take to the next level.

Development of human resources management in small and middle-sized enterprises can be recommended businesses need to concentrate on a specialized selection of employees, recruiting qualified and experienced workers who will become a competitive advantage. One more recommendation is that more attention should be paid to mentoring employees who can become highly qualified and

TABLE I. HR FUNCTIONS DEVELOPMENT STAGES.

HR as a business function	HR as a business partner	HR as a strategic partner
<ul style="list-style-type: none"> <li>• HR in an organization is responsible for managing employee data, payroll, time and attendance, and setting company policies</li> <li>• The role is largely that of personnel administration focused on both internal &amp; external compliance, and on management of employee records.</li> </ul>	<ul style="list-style-type: none"> <li>• HR focus shifts to competency-based recruitment, total compensation, employee development, and communication and organization design</li> <li>• HR helps in formalizing the organization structure</li> <li>• HR helps the organization attract and retain skilled employees by becoming a leader in compensation management</li> </ul>	<ul style="list-style-type: none"> <li>• Full maturity of HR function</li> <li>• Aligning employees to a common set of objectives derived from the mission and value statements</li> <li>• Identifying top-performers and non-performers</li> <li>• Continuously measuring of the effectiveness of leadership and employee satisfaction</li> <li>• Increasing employee engagement through appropriate measures</li> <li>• Aligning compensation to performance</li> <li>• Adjusting recruitment and training to competency gaps</li> </ul>

trained and loyal [1].

Among the literature, it can be found that great people are an organization’s most valuable asset. There is a belief that talent management must be embedded in the foundations of organizational culture, therefore different organizations require different talent management processes. In particular, the issue of social culture, to which a certain organization belongs, must not be forgotten as a cornerstone in defining terms. Different cultures have different values about what talent is and what is meant by talent management, i.e. what is the practice of human resource management in general. For example, in cultures that inherit the collectivist spirit, the team way of working and belonging to a certain group is emphasized. An exclusivist definition of talent, which refers to the individualization of the term, would be problematic for application in such countries, as it would individualize team members. Then the question can be raised whether this is appropriate, that is, whether it is the right

definition of the terms talent and talent management.

On the other hand, individualistically oriented cultures are strongly focused on self-esteem and personal achievement, in collectivist cultures the focus is on harmoniously fitting into the environment and personality does not stand out [7].

Rapidly changing market dynamics and global competitive pressures have caused organizations to spend more time focusing on their core business [8].

Due to the unprecedented disruptions caused by the COVID-19 pandemic, companies are introducing radically new ways of working and doing business, which puts human resources issues in focus [9].

The way people work and interact with technology has changed dramatically following the COVID-19 pandemic. According to the website Empxtrack [10], in order to survive in today’s digital world, organizations are looking for ways to streamline operations and processes and become more efficient, cost-effective, and agile. These technological tools can have a significant impact on the work environment and employee experience if used correctly.

Implementing practices can lead to higher business performance ensuring maximum employee satisfaction and smooth collaboration. More and more companies recognize the importance of adapting to the market and new trends. The employee is now in focus. It seems like it's never been harder to keep an employee.

Deloitte conducted a survey called “Human Capital Trends 2021” on a sample of 6,000 business and HR leaders from 99 countries. The aim of the research was to determine how the pandemic affected the ability of companies to survive and achieve their goals. Key findings are presented below.

- Employee welfare - Companies that manage to incorporate employee well-being into their daily work processes will build a sustainable future for themselves in which employees will perform their jobs at a high level of enthusiasm and productivity.
- Integration of artificial intelligence and employees - Integrating AI and employees helps companies use

technology to enhance teams' ability to learn, create and work in ways that produce better results.

- Unleash the full potential of employees - Improving the level of competences.
- HR analytics - An HR team that can draw valid conclusions will keep the company on the right track. Companies need to start making better use of the wealth of data they have at their disposal. First of all, they need to deeply analyze the data related to the potential and competencies of each individual employee.

### III. HR FUTURE TRENDS

The future of the HR function in organizations is uncertain. On the one hand, if it does not change, it could end up being largely an administrative function that managers an information technology-based HR system and vendors who do most of the HR administrative work. On the other hand, it could become a driver of organizational effectiveness and business strategy. In many organizations, one of the key determinants of competitive advantage is effective human capital management [11].

There are many predictions about how the future of HR function may look. Many HR trends will be embraced by employers. There is no doubt that the hybrid work model is going to be at the top of these trends. COVID-19 has forced organizations into remote and hybrid work models. After a few months of remote work, many organizations realized that the physical space, offices, and car parking are not needed anymore if employees decide to work from home [12].

A commonly present trend is also an employee experience. Gartner's survey on employee career preferences shows that just 1 in 4 employees voiced confidence about their career at their organization, and three out of four looking for a new role are interested in external positions [13].

Organizational culture and change management will stay the main priorities for HR managers. Employees may feel overwhelmed because of digital transformations, economic uncertainty, political tensions, and many other changes.

One of the most important predictions in HR

is the usage of data and artificial intelligence. Many organizations plan to deploy technologies to implement a large number of shared services or transactional agreements [14].

Quality of human resource management determined by the efficiency of the application of information technology [15].

HR analytics is all about collecting, organizing, and validating the data related to hiring, training and development, employee benefits, employee satisfaction, absenteeism, and retention to help managers make better decisions in all these areas. Data and analytics have become one of the most important, if not the most important, tools of HR, which are essential for making any strategic decision in business. HR data help organizations to improve the decision-making process related to employees, and thus to achieve the company's strategic goals more easily.

Today's work environment expects leaders to be more authentic, empathetic, and adaptive. The importance of the relationship between employees and managers is emphasized. Employees prefer active communication with their superiors and prompt feedback about their performance. Relationship with superiors is an important factor. A desire for good interpersonal relations, i.e., a good work climate, was also expressed to a large extent, as in [16].

The biggest challenges for HR after COVID-19 will be restructuring the place of work and the content of work, applying more advanced technology to recruitment, selection, and performance; more interest, appreciation, and motivation from managers will be needed as well as building trust, a sense of belonging among team members.

The list of benefits will be revised towards enhancing mental health and well-being. The reality after the pandemic will require new competencies from managers and employees so re-skilling and re-training are the most expected approaches [12].

### IV. HR PRACTICES IN SERBIA

A Serbia follows modern business trends in the field of human resources. The established forms of previous activity are being overcome and the importance and influence of human resources on the entire operation of the organization are recognized. Certainly, the presence of an increasing number of

multinational companies in the labor market has contributed to the increasing importance of the human resources function. After the COVID-19 pandemic and the current political uncertainties in the world, those companies that adapt to the needs of their employees will have a competitive advantage.

Every two years, the Infostud portal conducts research on what makes an employer desirable in the labor market, and for the second time in a row, the respondents put stable financial operations in the first place. In order for an employer to be attractive and desirable in the labor market, it is necessary first of all to have stable financial operations, according to Infostud's research. In second place are good interpersonal relations, and then what kind of attitude the employer has towards the employees.

Fortunately, there are companies in Serbia that have caught up with modern business trends and that, despite the multi-year transition process and the current world economic crisis, are successfully applying modern human resource management methods. In many companies, these trends came with a change in the ownership structure, and other companies, adapting to market requirements, gradually developed an awareness of the principles of modern human resource management, and in this sense, they began to apply other very important activities in human resource management in an organization such as talent management, knowledge management, change management and a modern approach to motivation and rewarding [17].

In the government and public sector, the selection of employees is made on a political basis, not on an educational basis, and not based on competencies and knowledge [18].

The importance of promoting good HR practices is recognized also on a national level. The Serbian Chamber of Commerce has been awarding the Djordje Weifert National Award for Socially Responsible Business since 2007. There are three award categories. Category of large companies, category of medium-sized companies and category of small and micro businesses [18].

Serbian Chamber of Human Resources Managers organizes the competition for the award "BEST IN SERBIA 2022" in human resources management and talent management with the aim of promoting and establishing the

principles and practices of responsible business operations.

The development of the labor market of the Republic of Serbia is evident, which is conditioned by the appearance of a large number of investments and companies, which are increasingly becoming competitors in terms of profit, but also a wide range of benefits, i.e. attracting talents and experts [19].

To better understand the current changes in the market, as well as the perception of future candidates, the company Assert International conducted a survey (October 2020) whose purpose is to identify the attitudes of existing talents in the territory of Serbia - precisely about future employers. Young generations give us answers to the question "Who do we want to work for?" and they give us the opportunity to make generational differences in expectations. One of the most important results shows that the so-called "Generation Z" expect from a future employer, in addition to salary (which they don't even rank as the most important), also: the possibility of professional development (72.58%), the possibility of advancement (71.77%), good interpersonal relations in the future company (68.55%) [19].

All the above indicates that human resources practices in Serbia are developed. An exception can be made and say that only in state institutions, HR functions are still on the business function level. Also, in small private companies, this function is not developed. It seems that for these two types of organizations employees in HR department are responsible for managing employee data, payroll, time and attendance, and setting company policies.

## V. CONCLUSION

The purpose of human resource management is to increase performance aimed at motivating, engaging, and retaining employees so that they perform better. When an organization has a clear HR strategy and organizational culture done right, companies can build a sustainable competitive advantage and outperform their competition through an integrated system of talent management practices that are difficult to copy and/or imitate. In other words, human resource management is a process that aims to achieve business plans through integrated people management practices. In this way, human resources have an active influence on the business results themselves. The paper has

searched current trends in HR management, especially in Serbia.

#### REFERENCES

- [1] Mura, L., Kljcnikov, A., Tvaronavicienė, M., & Andronicceanu, A., (2017). *Development Trends in Human Resource Management in Small and Medium Enterprises in the Visegrad Group*, Acta Polytechnica Hungarica
- [2] Dessler, G. (2017). *Human Resource Management*, 15th ed, Boston, Pearson
- [3] Orlić, R., & Ivanović, T. (2019). *Menadžment ljudskih resursa*. Beograd, Srbija: Fakultet organizacionih nauka
- [4] Opatha, H., (2021). A Simplified Study of Definitions of Human Resource Management. *Sri Lankan Journal of Human Resource Management*, 11,
- [5] Parry, E., Stavrou, E., & Lazarova, M., (2013). *Global Trends in Human Resource Management*, Palgrave Macmillan, Houndmills, Basingstoke, Hampshire
- [6] Komm, A., Pollner, F., Schaninger, B., & Sikka, S., (2021). The new possible: *How HR can help build the organization of the future*, Available at <https://www.mckinsey.com/capabilities/people-and-organizational-performance/our-insights/the-new-possible-how-hr-can-help-build-the-organization-of-the-future>
- [7] Brewster, C., Sparrow, P., & Vernon, G. (2007). *International Human Resource Management*, London: Chartered Institute of Personnel and Development.
- [8] Raja, D. V. A. J. (2012). Emerging trends in human resource management with special focus on outsourcing in various sectors. *International Journal of Management (IJM)*, 3(1), 197-204.
- [9] Stefanovic, I., (2021). *Kako je pandemija korona virusa uticala na sektor ljudskih resursa?*, Delloite Available at: <https://www2.deloitte.com/rs/sr/pages/about-deloitte/articles/kako-je-pandemija-koronavirus-a-uticala-na-oblast-ljudskih-resursa.html>.
- [10] Bhatia, T., (2008). Evolution of the HR Function, Available at: <https://empxtrack.com/blog/evolution-of-the-hr-function/>
- [11] Lawler, E., Boudreau, J., (2015). *Global trends in Human Resource Management*, Stanford University Press, California
- [12] Przytuła, S., Strzelec, G., & Krysińska-Kościańska, K. (2020). Re-vision of Future Trends in Human Resource Management (HRM) after COVID-19. *Journal of Intercultural Management*, 12(4), 70–90.
- [13] Turner, J., (2022). What Will HR Focus on in 2023?, Gartner, Available at <https://www.gartner.com/en/articles/what-will-hr-focus-on-in-2023>
- [14] Mushkudiani, Z., Gechbaia, B., Gigauri, I., & Gulua, E., (2020). *Global, economic and technological trends in human resource management development*. Access to Science, Business, Innovation in Digital Economy
- [15] Bileviciene T., Bileviciute, E., & Parazinskaite, G., (2015), *Innovative Trends in Human Resources Management, Economics and Sociology*, 8(4), 94-109
- [16] Ilic, B., Đukić, G., Nikolic, M., (2022). Rural tourism of Eastern Serbia: *Human resources management and motivation. Ekonomika Poljoprivrede*, 1, 241-255.
- [17] Stamenkovic, S., (2019), Analiza “HR-a” u Srbiji, Resurs, Portal komore menadžera ljudskih resursa Srbije, Available at: <http://www.resurs.rs/index.php/novosti/263-analiza-hr-a-u-srbiji>
- [18] Ilic, B., Djukić, G., (2021). Management and new tendencies of human resources - a comparison of Japan, America, and Serbia.
- [19] Mucalov, L., Erić, S., (2021). *Who do we want to work for*, Manpower, Available at: <https://manpowergroup.rs/knowledge/za-koga-zelimo-da-radimo>

# Measurement of Innovation in Economic Growth Research

Nataša Stanojević<sup>1</sup>, Slobodan Kotlica<sup>2</sup>, Katarina Zakić<sup>3</sup>

<sup>1,3</sup>Institute of International Politics and Economics, Belgrade, Serbia

<sup>2</sup>Faculty of Business and Law, MB University, Belgrade, Serbia

<sup>1</sup>natasastanojevic@diplomacy.bg.ac.rs, <sup>2</sup>kotlica@gmail.com <sup>3</sup>katarina@diplomacy.bg.ac.rs

**Abstract**—Research belongs to the field of methodology of economic sciences. The article analyzes the causes of the inability of economic models and indicators to measure the impact of knowledge and innovation on economic growth, despite the general agreement about their positive effects. The article presents the evolution of the inclusion of the knowledge variable and technological achievements in models of economic growth. Second, the quantitative innovation indicators were classified, and their limitations were assessed. Finally, two current processes that present new challenges for measuring the economic effects of innovations are analyzed: mass digitalization and the increasingly frequent occurrence of open instead of closed innovations. The goal is to separate obstacles for evaluating innovative effects that can be overcome from those that cannot due to the fluid nature of innovation. This distinction determines the optimal relationship between the methods and framework of economic growth research. The article results showed that reliable economic growth research must be primarily based on the measurement of direct innovative output, while input criteria (investment in R&D) and indirect outputs (number of patents) can only be auxiliary criteria. As data collection on the direct outputs of innovations implies extensive work by researchers, a lot of time and emphasized flexibility in data collection, and a significant geographical or sectoral narrowing of the research subject.

**Keywords** - innovation, knowledge, economic growth models, digitization, open innovation.

## I. INTRODUCTION

There are few concepts in economic theory about the meaning and role of which there is such broad agreement as innovation. The term innovation implies: the introduction of new

products or services; improving the quality of products or services; methods and processes by which they are created; or methods and processes of production organization. Beyond these basic elements of the concept, the authors also add the introduction of new raw materials and semi-products, breakthrough to new markets [1]; changes in the context in which the product or service is used, so called positional innovation [2]; application of new marketing methods including significant changes in design, marketing and promotion of products—marketing innovations, etc. Despite the large number of elements that authors attach to the concept of innovation, not one of them has been contested by other authors. In addition, there is general agreement about the positive role of innovation in the modern economy. Knowledge, technologies and innovations have an undeniably important role in increasing productivity, developing new products and services and creating competitive advantages for companies, which further contribute to accelerating the growth of the entire economy.

Despite the seemingly clear idea of the role of innovation in the growth and development of modern economies, evaluation and even less precise measurement of this impact have remained beyond the reach of macroeconomic research and models. The most commonly observed sources of the “elusiveness” of these effects differ to some extent. They often refer to the incompleteness of the available data or the fact that these data ‘represented only a proxy measure reflecting some aspect of the process of technological change’ [3]. As early as 1962, Simon Kuznets observed that ‘the greatest obstacle to understanding the economic role of

technological change was a clear inability of scholars to measure it' [4].

Innovation implies creation (invention) and the use of new knowledge to offer products or services with greater value for users. One of the essential elements of innovation is its verification on the market, i.e., commercialization. Innovation is 'invention plus commercialization' [5]. The criteria for evaluating the success of innovative activities and innovations are more commercial than technical, and innovation is considered successful if its commercialization provides a return on invested funds and a corresponding profit. However, the fluid nature of innovation does not allow a complete insight into all the manifestations of its application. Knowledge and ideas are the essential components of the innovation process, and the commercialization process is a confirmation of the success of R&D activities. The linearity of the process from the idea, through scientific discovery, invention, innovation, and technology, to the market is a one-way and unambiguous process that leads to technological and commercial success.

The goals of this research are to:

- 1) explain the results of previous research on the statistically invisible effects of knowledge and innovation in models of economic growth;
- 2) identify the advantages, disadvantages and scope of the set criteria for measuring innovation effects; and
- 3) explain the new challenges for establishing precise and reliable methods for measuring their effects, which are set by the action of two current processes – digitization and the prevalence of open innovations instead of closed ones at the beginning of the 21st century.

These results will enable the separation of obstacles for evaluating innovative effects that can be overcome from those that cannot, and based on that, to determine the optimal relationship between the methods and framework of economic growth research.

## II. TECHNOLOGY, INNOVATION AND MISSING VARIABLES IN ECONOMIC GROWTH MODELS

For a long time, economic theory recognized only the importance of new machines, that is,

technology, as a source of economic growth, while knowledge and innovation were viewed as default factors that did not need explanations. Technological growth and development is treated as an exogenous factor of economic activity, which has its own laws of a non-economic character and is beyond the subject and interest of economic science. According to the classic model, the product (output) is generated using two factors of production, labor  $L$  (labor) and capital  $K$  (capital). Any increase in productivity, therefore, would have to be caused by an increase in invested capital or the number of workers:

$$Y = F(K, L; t). \quad (1)$$

The sudden technological rise of the 1980s, the growth of investments in IT and the evident application of new technological solutions in the economy did not show up in productivity statistics. According to econometric models, productivity growth in the world economy lagged during the 1970s and 1980s, while at the same time, the computer and technological revolution was apparently making production more and more efficient. An economist Robert Solow famously said in 1987 that the computer age was everywhere except in productivity statistics. Similarly, Freeman [6] believes that there is a paradoxical situation between the general agreement that technological change is the most crucial source of dynamism in capitalist economies and the relative neglect of this issue in large part of the significant literature in the economic and social sciences.

At the same time, the model of economic growth begins to show increasing values of residuals, which means that significant causes of economic growth remained outside the equation and understanding of researchers.

Significant progress in the discovery of this phenomenon was represented by the works of Abramovitz [7], Denison [8,9], and Solow [10,11], who put forward the neoclassical theory of economic growth. In their empirical research and theoretical elaborations based on it, they pointed out that economic growth, apart from the nature of labor and capital, is influenced by other, unconventional factors, such as the role of knowledge, technique and technology in economic growth [12]. Knowledge and innovation are also seen as exogenous factors, but for the first time, they are included in models

of economic growth. However, more than a decade passed before their inclusion in the methodology of economic research, that is, until it was possible to assess their impact. In 1988, Lucas developed an alternative growth model based on externalities arising from the process of human capital accumulation, either through formal education or 'learning by doing' [13]. Lucas's model includes investments in human capital that are transposed into raising the technological level of the economy. Technological progress and knowledge are viewed at the level of overall knowledge of science, that is, as an exogenous factor in relation to the economy under investigation.

The most often cited model of exogenous growth is the Solow-Swan model of long-term economic growth, which, in addition to capital accumulation, labor or population growth, explains economic growth by increasing productivity caused by technological progress. The model has the following form:

$$Y(t) = K(t)^\alpha (A(t)L(t))^{1-\alpha}, \quad (2)$$

where  $t$  denotes time,  $Y(t)$  total production in a certain period, while  $A$  is the exogenously determined level of technical progress or total factor productivity, so that  $A(t)L(t)$  represents the effective workforce, instead of only the previous  $L$ , which refers to the number of workers.

In parallel with this approach, an approach was developed on technological changes and technological progress as an endogenous, cumulative and interactive process in relation to the economy and society. This point of view, which developed mainly within the Neo-Schumpertian and evolutionary approach to economic phenomena, prevailed in economic science for a short time. The endogenous growth theory and technological progress, based by Arow [14], offers more radical explanations of long-term growth. Like the previous model, growth is attributed to technological progress, with the critical difference being that it originates from within the economic system – a state or a company [14-16]. The model implies that the long-run equilibrium growth rate is determined by the level of accumulated human capital [17]. These authors assumed that investment in R&D and intellectual improvement of labor, helped foster endogenous innovation and fuel constant economic growth.

One of the most frequently cited endogenous growth models is Romer's [16]. It can be presented in the following way:

$$Y(t) = K(t)^\alpha (A(t)L(t))(A(t)H(y))TL, \quad (3)$$

where  $K$  is capital;  $A$  – knowledge, ideas;  $L$  – labor in production;  $H$  – human capital – which includes activities such as formal education and training of employees;  $TL$  – the index of technology level.

The measure of internal innovation potential is shown as the ratio between the number of researchers in relation to the number of employees in production. Romer emphasizes that economic growth is more substantial with a more favorable relative relationship between the amount of human capital and ordinary labor.

These assumptions also cannot be accurately measured. Not a single model has fully explained the nature of modern economic growth because each contains a smaller or larger value of residuals (unexplained factors). This value decreased during the evolution of the economic growth model from the classic to the endogenous growth model. Reducing the impact of unknown factors can be attributed to difficult-to-measure changes such as improved work quality, better training and experience, and inventions embodied in the construction and application of new machines. However, in a large number of cases of structural or dynamic analysis of the growth of a particular economy, the residuals remained very high; that is, the influence of unknown factors was too often and remains unacceptable.

In response to the missing variables of knowledge, technology and innovation in models of economic growth, several international organizations have offered different variants of a composite index for measuring innovation in the past decade. As these are not econometric models, statistical relevance cannot be assessed, nor can the size of the residuals, i.e., the indices themselves are not subject to evaluation. We will mention only a few: EU with Innovation Union Scoreboard (IUS), World Economic Forum (WEF), Bloomberg, and World Intellectual Property Organization – WIPO. The selection of factors in very diverse combinations has no theoretical basis and is left to the relatively arbitrary judgment of the experts involved in creating the index. The absence of a system is



attempted to be compensated by a large number of variables, so these indices include several dozen, even over 100 factors, although the number of variables itself is not necessarily related to a more precise measurement. Bearing in mind the numerous specificities that occur in economies and societies, composite indices can hypothetically lead to moving away instead of approaching a precise evaluation of achievements in innovation. International databases on national innovation achievements have remained a source of tentative estimates, finding their place more often in political rhetoric than scientific research. To date, no simple criteria and methods have been identified for measuring the effects of innovations in the conditions of the modern global economy.

### III. QUANTITATIVE INDICATORS OF THE INNOVATION EFFECT AND THEIR LIMITATIONS

At the heart of the challenge of measuring innovation effects is the issue of selecting criteria for their evaluation. In the broadest sense, all indicators used to quantify innovations (either for their use in economic models or indices) can be classified into three groups:

- 1) direct input into the innovation process, such as costs or funds allocated for research and development (total, domestic, foreign, state or company level, etc.); the number of researchers in absolute number or concerning the number of employees in the company or the national economy, the number of highly educated workers employed; IT inputs in the form of equipment or number of qualified users, etc.;
- 2) an intermediate output of the innovation process through the number of innovations that have been patented, the number of inventions that have been registered in accordance with the norms of copyright protection and intellectual property rights;
- 3) a direct measure of the innovative output of the innovation process, which valorizes what is not only patented but also applied. These can be new technological procedures, processes, means and methods that are effected in a new technology, product or service [17].

In the conditions of the modern economy based on knowledge, these factors show

increasing limitations and decreasing precision due to the disrupted usual links between consumption, production and investment.

Regarding the first group of quantitative criteria – inputs, even in theory, there is no convincing evidence that more significant allocations to the R&D area result in higher quality and economically applicable knowledge production. A high level of allocation for R&D purposes is neither a necessary nor a sufficient assumption for the high effectiveness of the innovation process. When there is no adequate coordination and interaction with all other essential elements of the inventive-innovative chain, investment in R&D does not lead to innovation. Even when research investment leads to innovation, it does not mean that it will contribute to economic growth because the capacity to absorb inputs and generate outputs is very different between countries.

The next problem of input criteria is the fact that not all innovations are generated by R&D expenditures. In fact, the largest number of innovations are the so-called incremental innovation. In contrast to radical innovations that bring novelty on a global level, incremental ones arise during the work process and refer to the improvement of products, processes and methods without significant investment in research. Although they are not the result of radically new technological knowledge and scientific breakthroughs, they have significant economic consequences over time. The effects of incremental innovations cannot be precisely measured. In contrast to operational innovations, which make previous technical and conceptual solutions uncompetitive and replace them relatively quickly, incremental innovations are implemented in parallel with previous solutions in an undefined scope and duration.

The second group of quantitative criteria refers to the quantification of intermediate output, measured by the number of registered patents and other forms of intellectual property in relation to GDP or the number of SMEs with new products concerning the total number of companies, etc. The problem with this quantification criterion is that patents measure inventions rather than innovations, and secondly, firms often use methods other than patents to protect their innovations.

Due to the specificity of economies and societies, these two groups of readily available quantitatively measurable data can exhibit an

unlimited number of deviations. Although these criteria cannot provide precise measures for researching the economic effects of innovations on a broader level (sector, national economy, global level), they are essential for evaluating the effects of innovations on a microeconomic level, i.e., within the framework of companies. In addition, the criteria of inputs and indirect results are necessary at the level of a group of companies located in a specific geographical area, that is, in the same environment, which are homogeneous in terms of the mentioned possible differences.

The third group of criteria – the direct economic results of innovations – are quantitatively measurable only at the lowest aggregate level – insight into the results of individual innovations. Research which is based on these criteria provides the most appropriate information on the impact of innovation on economic growth and provides a basis for further quantitative research on the relationship between economic parameters and the innovation process. The problem is collecting them. A common problem of existing innovation statistics is the lack of the ‘output’ side of the innovation process. One of the more extensive examples is the U.S. Small Business Administration Innovation Data Base, which compiled the data by examining over one hundred technology, engineering, and trade journals, spanning every industry in manufacturing. As such a database is not helpful for researchers outside the US, direct output innovations require field research and often involve surveys of targeted groups of businesses in a specific geographic area. Only research based on these criteria can provide meaningful and valuable assessments of the effects of innovation on the economic growth of a specific geographic area or a clearly defined product group (by summarizing the effects of individual innovations). Measuring the effects of innovation at the macroeconomic level using these criteria is possible but unlikely. It requires forming a kind of interactive mass database with the decisive participation of the companies themselves or innovators – entrepreneurs, who generally have no interest in this additional expenditure of time.

It seems that the very fluid nature of knowledge and innovation presents researchers with the alternative of reliably measuring the economic effects of innovations at a narrow level – a sector, a group of companies or a geographical area, or a rough assessment of the effects at a national (or broader) level.

#### IV. NEW CHALLENGES IN THE EVALUATION OF INNOVATION EFFECTS

At the beginning of the 21st century, economic research methodology is facing new challenges and missing variables, even in research limited to sectors, geographical areas or a group of companies. Two current processes in the field of innovation further relativize the results of measuring innovation effects. The first is the expansion of innovation in digital technologies; the second is the expansion of open versus closed innovation.

##### A. *Digitization*

The template is used to format your paper and style the text. All margins, column widths, line spaces, and text fonts are prescribed; please do not alter them.

Newer digital technologies such as cloud computing, e-commerce, mobile internet, artificial intelligence, machine learning and the internet of things, although apparent products of the knowledge economy, have broader impacts than can be assessed by quantitative criteria related to their use. Digital technologies improve production in a sense that goes far beyond the optimization of economic processes in the classical sense. Business models are being fundamentally transformed, value chains are changing, and the boundaries between economic sectors are blurring.

Several models have emerged over the past few years, designed to assess a company’s digital status. Primarily developed and published by practitioners, the academic value of these models remains apparently unclear. Most existing models are tested through actual data, but the quality of the methods and approaches applied broadly differs or cannot be evaluated at all. The results of the extensive analysis of Thordsen, Murawski and Bick of the existing models for measuring companies’ digital maturity pointed out several shortcomings [18]. The models were evaluated on established academic criteria, such as generalizability or theory-based interpretation, and the results showed that these models could not have a general character; that is, they do not represent a universal method of measuring digitalization.

The impossibility of measuring the effects occurs in all evaluation phases, from defining the shift in digitalization in a specific company or sector through defining measurement procedures

and theoretical foundation of methods to the problem of generalization [18].

### B. Open Innovation

Another process is the growing influence of open versus previously dominant closed innovation, whether driven by digitalization or strategically set as a goal by companies.

Until the end of the 20th century, models of the innovation process were, more or less, closed innovation models. The process of development and commercialization of new products and services took place within the framework of a specific company or group of companies in the internal R&D process. In a closed innovation system, employees within the organization develop innovative ideas internally without exchanging ideas with the external environment (Fig. 1).

Since there are many ideas at the beginning of that process and significantly fewer at its end, it is possible to visually represent the innovation process as a funnel with numerous ideas that enter at its wide end (on the left of the figure), are transformed, with complex and extensive but invisible work within the funnel itself in several more significant innovations that appear on the market through the narrower part (on the right side of the figure). Although this direct effect of innovation on economic growth is immeasurable at the national level, the results were satisfactorily measurable at the level of companies and groups of companies.

At the beginning of the 21st century, companies from various industries, especially from the field of high technologies, are significantly changing or have already changed the dominant model of innovation activity. The innovation process is increasingly complex and involves an increasing number of participants to realize the commercial potential of innovative ideas as successfully as possible. Instead of focusing on internal idea generation and

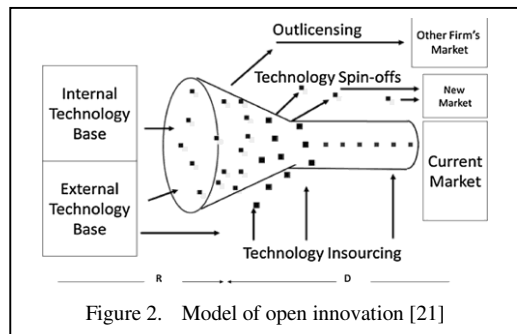
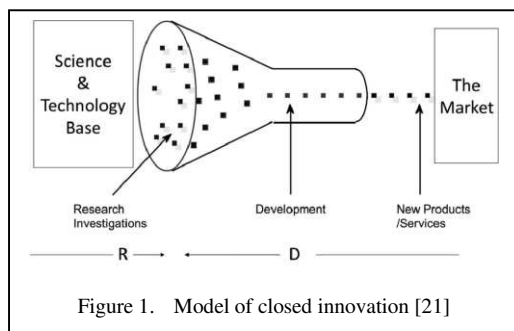

development, it combines internal and external ideas with internal and external paths to market to advance the development of new technologies [19].

One of the authors with the most significant contribution to open innovation research, Henry Chesbrough, explained them as follows: ‘Open innovation is the use of purposive inflows and outflows of knowledge to accelerate internal innovation, and expand the markets for external use of innovation, respectively. This paradigm assumes that firms can and should use external ideas as well as internal ideas, and internal and external paths to market, as they look to advance their technology’ [20].

The part of open innovation that is directed from the environment to the firm opens the company’s innovation process to numerous types of external inputs and contributions (e.g. consumers, suppliers, scientific institutes, universities, and engagement of external resources through an open call (crowdsourcing). The opening of the innovation process from the company to the environment implies that the organization enables unused or little-used ideas to leave the company and for other companies to use them in their operations and business models (commercialization of ideas and technologies by paths beyond the borders of the company and its business model). As the idea of the futility of trying to protect intellectual property becomes dominant, open innovation is equated with open-source software development.

The modern concept of open innovation is characterized by very fluid interactions between internal and external innovation activities. Ideas, people and resources move in different directions, and the boundaries between internal and external activities and the essential business environment of the firm are more porous (Fig. 2). Inflow and outflow of innovation contribution are possible at every point between innovation inputs and market placement. This leads to the

fact that even previously functional quantitative criteria related to inputs and intermediate outputs are becoming less and less precise.

## V. CONCLUSION

Although innovation is considered one of the most critical drivers of economic growth, evaluating this impact seems to remain a constant challenge for economic science. The fundamental problem is the absence of adequate measures which would enable a reliable evaluation of innovation activities at the macro level, such as the impact on economic growth, comparison between economies, regions, industries or different phases within one economy.

In modern knowledge-based economies, the usual links between consumption, production and investment have been significantly altered so that a certain amount of input produces very different outputs. Although economic growth models in a certain period of recent history allowed for relatively precise analyzes of economic structure and dynamics, in the conditions of the knowledge economy, positive economics faced the impossibility of achieving the reliability of natural and technical sciences. The decades-long efforts of positive economics to establish economic relationships as causal, instead of viewing them as stochastic, which is the nature of all social phenomena; to set the empirical model as a goal instead of as a means to support the creation of economic policies; they led to the separation of fundamental research from the reality of concrete society. The dynamics of real processes in the global economy are increasingly disproving the fundamental “laws” in the economy. The elusive economic effects of innovations in digital technologies, the porosity of innovation creation channels and the incredible intertwining of economic activities, subjects and states due to intense economic globalization have only made this fact more visible.

This does not mean that the economy should not analyze the effects of innovations but that the content, goals and methods should be adapted to its social nature. In order to quantify innovations, no matter how much their nature changes, the following criteria are used: 1) input into the innovation process (investment of money, technique, experts and time); 2) indirect outputs (patents); and 3) a direct innovative output (economic results of applied inventions, whether they are patented or not).

An objective analysis of the economic effects of innovations must rely on the third group of criteria – a direct innovative output (the financial results of applied inventions, whether patented or not). Criteria related to inputs and intermediate outputs may or may not be analyzed according to research objectives. Collecting data from this group of criteria implies investing a lot of effort, time, flexibility in data collection, and significant geographic or sectoral narrowing of the research subject, which explains a relatively small number of the research involves this kind of measurement.

## REFERENCES

- [1] Schumpeter, J. A. (1934). *The Theory of Economic Development*. Harvard University Press.
- [2] Francis, D., & Bessant, J. (2005). Targeting innovation and implications for capability development. *Technovation*, 25(3), 171-183.
- [3] Acs, Z. J. & Audretsch, D. B. (2005). Entrepreneurship, Innovation and Technological Change. *Foundations and Trends in Entrepreneurship*, 1(4), 149-195.
- [4] Kuznets, S. (1962). Inventive activity: Problems of definition and measurement. In R.R. Nelson (ed.), *The Rate and Direction of Inventive Activity* (pp. 19-43). National Bureau of Economic Research, Conference Report, Princeton, NJ.
- [5] Freeman, C., & Soete, L. (1997). *The Economics of Industrial Innovation*. Frances Pinter Publishers.
- [6] Freeman, C. (1994). The economics of technical change. *Cambridge Journal of Economics*, 18(5), 463-514.
- [7] Abramovitz, M. (1956). Resource and Output Trends in the United States Since 1870. *American Economic Review*, 46, 5-23.
- [8] Denison, E. F. (1962). *The Sources of Economic Growth in the United States and the Alternatives before Us*. Committee for Economic Development, New York.
- [9] Denison, E. F. (1979). *Accounting for Slower Economic Growth examines labor productivity and productivity accounting during the 1970s in the United States*. Brookings Institution.
- [10] Solow, R. (1957). Technical Change and the Aggregate Production Function, *The Review of Economics and Statistics*, 39(3), 312-320.
- [11] Solow, R. (1959). Investment and Technical Progress. In K. Arrow, & Suppes (Eds.), *Mathematical Methods in the Social Sciences*, Stanford.
- [12] Kotlica, S., & Stanojević, N. (2017). *Technology, innovation and competitiveness in a globalized economy*, Dositej, Belgrade. [Tehnologija, inovacije i konkurentnost u globalizovanoj privredi].
- [13] Lucas, R. (1988). On the mechanics of economic development. *Journal of Monetary Economics*, 22(1), 3-42.
- [14] Arrow, K. (1962). Economic Welfare and the Allocation of Resources for Invention. *The Rate and Direction of Inventive Activity: Economic and Social*

- Factors*, 609-626. National Bureau of Economic Research, Inc.
- [15] Romer, P. M. (1986). Increasing Returns and Long Run Growth. *Journal of Political Economy*, 94(5), 1002-1037.
- [16] Romer, P. M. (1990). Endogenous Technological Change. *Journal of Political Economy*, 98(5), Part 2, 71-102.
- [17] Mervar, A. (2003). An essay on recent contributions to the theory of economic growth. *Ekonomski pregled*, 54(3-4), 369-392. [Esej o novijim doprinosima teoriji ekonomskog rasta]
- [18] Thordsen, T., Murawski, M., & Bick, M. (2020). How to Measure Digitalization? A Critical Evaluation of Digital Maturity Models. In *Responsible Design, Implementation and Use of Information and Communication Technology*, 19th IFIP WG 6.11 Conference on e-Business, e-Services, and e-Society, South Africa, (pp. 358-369).
- [19] Kotlica, S., & Stanojević, N. (2020). From closed to open innovation. *Ekonomski vidici*, 25(3-4), 155-170. [Od zatvorene ka otvorenoj inovaciji].
- [20] Chesbrough, H. W. (2006). Open innovation: a new paradigm for understanding industrial innovation. In Chesbrough, H. W., Vanhaverbeke, W., West, J. (ed.). *Open innovation. Researching a new paradigm*. Oxford University Press.
- [21] Chesbrough, H. W. (2012). Open Innovation, Where We've Been and Where We're Going. *Research-Technology Management*, Special Issue: Open Innovation Revisited, 55(4), 20-27.

# The Way to Understand the Use of Technology for the Purpose of Developing Gastronomic Tourism

Drago Cvijanović<sup>1</sup>, Tamara Gajić<sup>2</sup>, Dragan Vukolić<sup>3</sup>

<sup>1</sup>Faculty of Hotel and Tourism Management, University of Kragujevac, Vrnjačka Banja, Serbia

<sup>2</sup>Geographical Institute “Jovan Cvijić” SASA, Belgrade, Serbia

<sup>3</sup>Faculty of Tourism and Hotel Management, University of Business Studies, Banja Luka, Bosnia and Herzegovina

<sup>1</sup>dvcmmv@gmail.com, <sup>2</sup>tamara.gajic.1977@gmail.com, <sup>3</sup>vukolicd@yahoo.com

**Abstract**—People began to prefer gastronomic tourism in order to learn and experience the culture of eating and drinking through a departure from the classic vacation concept. Gastronomic tourism as a special type of tourism in the Republic of Serbia is increasingly taking an important place in the research of experts. The goal of this research was to determine whether and to what extent technology can predict the choice of gastronomic offer in Serbia. The research was conducted during 2022 on a total sample of 365 respondents. The results show that social networks are of great importance when it comes to choosing a gastronomic offer. Technologies have an impact on the development of gastronomic destinations in Serbia. This paper has a significant practical contribution because the data can be used by the owners of catering establishments and other actors in Serbian gastronomic tourism.

**Keywords** – technology, gastronomy, tourism

## I. INTRODUCTION

Tourist demand has shifted dramatically over the last two decades. Food is no longer just a basic human need; it has also become one of the primary motivators for tourists to travel [1]. Gastrotourism alters the attitude of the environment in which it develops while also bringing about certain changes. Maintaining positive attitudes among all participants in gastrotourism is important for several reasons, one of which is visitor satisfaction [2,3].

Gastronomy is an important segment in the global development of tourism. Gastronomy in the Balkan countries gained popularity after the 1990s, so as a relatively new topic in academic literature, it is frequently critically monitored, influencing future development [4]. Gastronomy is a combination of experience, culture, and food and beverage tasting [5].

Gastronomic tourism is defined as the study and exploration of culture and history through food, which influences the formation of unforgettable experiences [6]. The significance of certain food attributes and the impression that food leaves on tourists is critical for the development of tourist loyalty [7]. Marketing experts emphasize the importance of destinations ensuring that advertising or marketing campaigns effectively attract potential tourists [8].

Various websites, such as Facebook, Twitter, LinkedIn, Instagram, and various blogs that allow interaction between people with similar interests, have grown rapidly in recent years. Younger generations of workers, as well as those who have yet to enter the labor force, have learned to use social networking tools to connect, exchange ideas, information, or their attitudes and emotions [9]. Given that Instagram has been tested as a marketing tool [10,11], there are implications for how gastronomic destinations develop.

Because of Serbia's great gastronomic potential, as well as the impact of gastronomic tourism development on the overall development of the economy, the authors approached the research with the goal of determining whether, and to what extent, social networks can predict restaurant choice and gastronomic offer in Serbia. Serbian gastronomy has a significant impact on tourism development, so this research has a broad scientific and practical contribution. According to this fact, the paper's authors conducted a survey to determine the extent to which social networks influence consumer awareness, specifically the choice of restaurant and type of food.

## II. LITERATURE REVIEW

Culinary tourism, also known as gastronomy tourism, is the most commonly used term to describe a type of tourism that emphasizes a relationship between the insider and outsider created through food as culture. The term is used throughout the relevant literature to suggest an undeniable and intrinsic link between food and culture, distinguishing it from other similar terms. Culinary tourism is the experience of the "other" through food-related activities that facilitate cultural learning and knowledge transfer about the destination and its people. Food is viewed as a medium of cultural experiences in culinary tourism; thus, 'culinary tourism' is defined by the experience of food activities and subsequent cultural consumption, as well as the motivation behind the individual's involvement [12]. Kaplan and Haenlein (2010) [13] are in Concepts of Web 2.0 and UGC, proposed that social media refers to "a group of Internet-based apps that build on the ideological and technological foundations of Web 2.0, and that allow the creation and exchange of user generated content". Filo et al. (2015) [14] defined social media as new media technologies facilitating interactivity and co-creation that allow development and sharing of user-generated content among and between organizations and individuals. Obar and Wildman (2015) [15] further reviewed the literature on social media and identified four unique dimensions, namely Web 2.0, UGC, creation and interaction and based on that definitions, social media can be summarized as Web 2.0-based online platforms that enable and promote the users' independent creation and sharing of UGC. However, contemporary literature demonstrates lack of unified classification systems for social media [1,2,8,15,16]. Based on the theories in media

research and social process Kaplan and Haenlein (2010) [13] categorized social media into six types according to their usage characteristics. The six types are collaborative projects, blogs, content communities, social networking sites, virtual game worlds and virtual social worlds. This classification has two dimensions. The second dimension describes social media as a tool of self-presentation and self-disclosure, which involves impression management and public sharing of personal information [16]. With the advancement of information and communication technologies, tourists rely on up-to-date and timely information obtained from social networks, online reviews, blogs, and other sources before traveling [17]. People nowadays create their own content and update information online via user content [18]. Companies can use social media to interact with network users and collaborate to create unique services and share travel experiences [19]. Instagram is a new and popular tool in digital tourism that has successfully evolved into a platform for advertising, promotion, and marketing [20,21].

Attention must be paid to the popularity of the publication, which has a significant impact on business success, in order to effectively attract the interest and attention of people on social networks [22]. According to the post popularity model, the presentation, links, content, frequency, and comments of the post are critical factors related to the user's "liking" [23]. Academics have been debating destination marketing, branding, and e-Tourism in recent years. Despite its importance, the majority of the literature has focused on Facebook and TripAdvisor [24]. More and more destinations are striving for branding, in order to build a reputation through various media [25]. Destination branding has to do with local people and local government [26]. Overall, visitor preferences and attitudes towards the destination are key factors that directly affect success and then shaping the image of the destination that may be related to gastronomy [27]. It has been proven that the image of local gastronomy influences the intentions of tourists to visit that destination [28] ie, food consumption has recently become one of the main motivations for people to travel. Although the concept of destination image through gastronomy is still relatively new in the academic community [27] researchers are becoming increasingly interested in the motivations of gastronomic tourists. Food, according to Fields (2002) [29], can be a different

motive. This relates to the fact that food can be both a physical and cultural motivator, as well as a status symbol. Kim et al. (2009) [30] looked into how food can still be used to motivate people. They were led by the belief that

A survey of 406 respondents was conducted in mainland China (considered one of the fastest growing and most influential markets for the use of social networks by tourists) to demonstrate the use and trust of Chinese social networks in the travel planning process. The authors concluded that destination marketing organizations should keep in mind that Chinese tourists prefer to plan trips using social media platforms such as Instagram, Facebook, and others. The same authors also state that social networks are a powerful tool for tourism development, and that in China, the use of these networks is encouraged by the advancement of communication technology and tourism [31]. Research by Dossena et al. (2021) [32] suggests that the theoretical framework of social media could be strategically used for different goals by relying on specific capabilities and competencies. The authors tested it and found that, though? nowadays restaurant managers mainly focus on a narrow set of social media competencies linked to relational and marketing capabilities, some also rely on social media to promote organizational change and innovation.

According to Jiménez Beltrán et al. (2016) [33], overall satisfaction with the visit is related to local gastronomy. According to Lai et al. (2018) [27], food opinion as a whole can be analyzed by demand (tourists) or supply (locals) (service providers). More and more cities in China are utilizing social media to market and promote their products and services online [34]. Previous research indicates that such practices provide significant benefits to societies through community interaction in marketing campaigns. According to Zhou and Wang (2014), [34] in their research, social networks are a more convenient and transparent platform for potential tourists than the traditional approach. The term, user-generated content, refers to any form such as images, videos, or texts that users post via social media. Authors Burgess et al. (2009) [35] point out that people post reviews, comments and feedback, as well as share information but also communicate with each other online. In recent years, social media posts have been increasingly used as an online marketing tool by local governments, travel organizations, and travel agencies. It is important to note that tourism is

ranked as the largest industry in terms of the volume of online transactions [36]. Chua & Banerjee (2015) [37] indicate that the interaction with consumers is significantly influenced by posts (comments and other feedback) on social networks, both during and after the trip, which has a great impact on further business. Travel experiences, as such, can be created together in a group of multiple people, consumers or tourists. The best examples of well-known social networks are Instagram, Facebook, TripAdvisor and the YouTube channel. Previous research has analyzed travel reviews on TripAdvisor to investigate how comments on that network affect the travel planning process of travelers. Online reviews have been found to influence accommodation decisions more than the entire travel route [38]. Another study looked at hotel ratings and how tourists felt after reading online reviews on TripAdvisor [39]. Mariani et al. (2016) [40] conducted big data analysis and semi-structured interviews to investigate how Facebook can be strategically used in destination marketing in the case of Italy, whereas Sabate et al. (2014) investigated Facebook in terms of the creation of effective branding strategies through the use of social networks. According to the findings, the richness of the content (the inclusion of images and videos) increases the post's impact in terms of likes. However, the use of images and a proper publication time have a significant influence on the number of comments, whereas the use of links may reduce this metric (Sabate et al., 2014). A newer marketing tool in digital tourism is Instagram, which is getting more and more attention from researchers. This is a photo-sharing platform created in 2010. It is interesting that the Instagram of companies, catering facilities, tourist organizations and agencies joined only a few years ago [15,28,48].

Instagram has become an effective business tool to reach consumers and tourists as soon as possible. Through Instagram, service providers can communicate with their consumers and get their support through Instagram, in a very short time. This network is gaining in popularity because it has about 100 million active users per month worldwide with 5 million posts shared every day [15,28]. Some of the previous literature has examined how Instagram helps promote and brand a destination through photography in the case of Indonesia [18]. Women who use Instagram between the ages of 18 and 30, in order to find out if it has anything



to do with buying products and services with celebrities. They came to the result that women of the mentioned age buy more if a certain product is offered by a famous and famous person, regardless of the brand of that product or service [42-44]. In the case of social media, the link or link inserted in the post is more interactive with network users compared to content that contains only texts [46]. The situation is similar with posts that have geo-tags or hashtags. Their function is the same as the links because URLs cannot be clicked in posts or comments on Instagram yet. The interactivity of posts must be taken into account because consumers prefer to interact with certain brands, often ask questions through social networks and it is a key feature in generating posts. Taylor et al. (2011) [41] have shown that posts that are considered fun and exciting have a positive impact on consumer attitudes. Moreover, consumers prefer informative posts driven by the need to seek information to motivate shopping. Posts also necessitate the organization of the format by marketing professional. Lin et al. (2017) [42] demonstrated that the length of the post has a direct impact on the interests of users. Long posts on Facebook are more favorable, whereas Sabate et al. (2014) claim that posts with less than 80 characters are more influential in interacting with social media visitors. It is critical to note that the time of publication of a particular post is significant [40]. Mariani et al. (2016) [40] found that publications published in the early morning hours are less popular compared to publications published during the largest number of consumer activities in the evening [42]. In this regard, the authors Mariani et al. (2016) [40] point out that posting too often is inefficient and can negatively affect sales or promotion. The usefulness of comments on social networks refers to how positive or negative the comments are. Previous research has indicated that positive comments lead to greater popularity due to the emergence of positive emotions among social media users [43]. The more comments, the more subsequent comments will probably be generated and lead to greater popularity of posts [44]. While likes indicate users' interest in a particular post, commenting suggests a big impact because users are asked to dedicate their time, and implies greater engagement of social media users [22]. Because consumers like to communicate with other users through social networks, this can be used to create experiences with potential consumers together. Drummey (2017) [45] warns that in addition to the quality content of the

campaign itself, it is equally important to choose the right social network through which organizations will reach the desired target group. Although no quantitative results were provided, study authors, Bartle et al. (2013) [47] found that the process of information sharing among social network members could play a functional role in the diffusion of instrumental travel information. It also could play a social role whereby perceived in-group membership (i.e., those who cycle to work) and high levels of trust reinforce positive views of cycling.

While social networking can help strengthen guest loyalty and satisfaction, it can also lead to unfair negativity, inaccurate information and undue criticism [48,49].

Based on the given literature and similar research, the authors started from the initial hypothesis:

H1: Technology have a strong predictive power to determine the score on a criterion variable;

H2: Recommendation has strong predictive power to determine score on criterion variable;

H3: The second type of marketing has a strong predictive power to determine the score on the criterion variable.

### III. METHODOLOGY

#### A. *Participants and Procedure*

The questionnaire was constructed, modified and adapted so that the authors could use several other scientific researches [3,7,9,50]. About 43.2% of men and 56.8% of women participated in the research. The largest percentage of research participants have a university degree 59.3% of them, while a total of 32.6% have a high school diploma, and 8.1% have a PhD degree. Looking at the monthly earnings of survey participants, the data are as follows: a total of 11.8% earns up to 200 euros per month; 42.7% of them from 200 to 500 euros per month, and 45.5% of those who earn from 500 to 1,000 euros per month.

#### B. *Measures and Statistical Analysis*

Exploratory multivariate data analysis is the unification of research data analysis and multivariate data analysis. Reducing the number of variables in the analysis when there are too many, with some of them "overlapping" because they have similar meaning and behavior. Factor analysis is an interdependence technique because

it looks for a group of variables that are similar in the sense that they “move together” and therefore have great interdependence. When one variable has a large value, then the other variables in the group have a large value. Since the factors are statistically separated, all factors are initially unrelated (orthogonal). This simplifies the understanding of a wide range of variables that describe a category from the service or manufacturing sector.

A framework for further data analysis is also being created. Then, a higher order factor analysis was performed to obtain the desired number of factors, and the following analysis was performed. After determining the number of factors, the authors performed a multiple regression analysis to determine whether the relevant factors can have a strong predictive power in determining the score on the criterion variable restaurant selection and gastro offer in Serbia. If the problem we are observing can be treated as a problem of one dependent and several independent variables, this is a suitable situation for data analysis by multiple regression. If the connection between them is linear, the case boils down to a multiple linear model. Each corporate site provides the opportunity for users to check the content or offer. A ComScore report shows that 45% of tourists download photography or comment on social networks after using the service : <http://www.comscore.com/FutureinFocus2013>

#### IV. RESULTS AND DISCUSSION

The parametric methodology was used, because all values were normally distributed. Skewness and Kurtosis values range from minus 1 to plus 1, which are values of normal data distribution. The value of Cronbach's alpha is 0.967, which makes the questionnaire very reliable.

Table I shows the descriptive values for the given items, which concern the influence of social networks on the gastronomic offer in Serbia. It is noticed that social networks like Instagram have a great influence on visiting restaurants and choosing gastronomic products. Facebook is rated slightly worse. A certain part of the research participants thinks that it is the best recommendation from a friend.

Respondents believe that Instagram gives the best recommendations, for luxury restaurants and offers, but also that it is reliable and dedicated mainly to foreign visitors.

TABLE I. DESCRIPTIVE STATISTICS FOR ITEMS

<i>Items</i>	<i>m</i>	<i>sd</i>
I prefer to accept recommendations for restaurants and food from friends	2.48	.884
I check everything on Instagram	2.35	.648
I mostly follow advertisements about restaurants and gastronomic offer	2.12	.287
I follow advertising emails	1.89	.852
I follow blogs	1.68	.764
I follow events and gastronomic events in the city	1.32	.821
Social networks promote mostly foreign cuisine	1.37	.635
Instagram gives the best recommendations	2.52	.817
I'm looking forward to long posts on social media	1.88	.693
Social networks only give expectations	1.94	.899
I get the best ads through the facebook network	1.65	.924
I watch TV commercials mostly	1.11	.769
I collect flyers and follow the gastronomic offer	1.44	.790
Social networks unrealistically present gastro products	1.69	.802
Mostly luxury restaurants are presented	2.24	.830
Social networks are only good for foreign visitors	2.26	.805
The price most influences the choice of gastronomic offer	2.41	.736
Social networks show quality gastronomic offers	1.90	.981
I follow influencers and their offer	2.87	.931
I follow the offer in the newspaper	1.98	.943

Source: authors research, \**m* = arithmetic means; *sd* = standard deviation

Also, a large part of respondents point out that price plays a role in choosing restaurants and gastronomic offer. Losses were rated television commercials, followed by newspaper offers, as well as flyers distributed on city streets.

The KMO and Bartlett's Test is a test conducted to examine the strength of a partial correlation (as factors explain each other) between variables. The factor structure matrix contains factor loads that represent the correlation coefficients between the selected factors and variables. All items are classified into seven factors. The first factor has the highest saturation of 18.436%. The model explains a total of 75.8% of the variance. Due to the difficulty of adding names to factors due to different items, the authors performed a higher order factor analysis or hierarchical factor analysis, in order to obtain only three desired factors, whose predictor impact will be determined by regression analysis.

Data from the hierarchical factor analysis indicate that 61% of the variance was explained with three obtained factors, which is more than half of the explained variance and is very acceptable. Three factors were obtained: The impact of word of mouth advertising, The impact of social networks, Other ways of marketing. Then, the authors approached a multiple regression analysis, to determine whether the given factors can be strong predictors in predicting the score on the criterion variable, which was: restaurant selection and gastronomic offer. It is noticed that this model fits and explains 68% of the variance. Coefficient R, is the coefficient of multiple correlation and indicates how many predictors together correlate with the criterion variable, in this case the variable of the required innovation.

Furthermore, ANOVA test it can be noticed that there is statistical significance in the predictor power of the factors on the prediction of the criterion variable. Given the statistical significance, a model of multiple regression analysis can be further developed to see the partial contribution of each of the given items to the criterion variable.

Multiple regression analysis shows the partial contribution of each of the factors and the statistical significance in predicting the choice of restaurant and gastronomic offer. The choice of restaurants and gastronomic offer significantly predicts oral advertising:  $p = 0.34$ ,  $B = 0.312$ ,  $\beta = 0.188$ . However, other types of advertising do not show statistical significance in predicting the criterion variable. The first two hypotheses have been confirmed, that social networks have a predictor of power on consumer behavior in choosing restaurants and agro offers, as well as the fact that Instagram has an advantage in this. While the third hypothesis H3 is denied.

The results undoubtedly show that social networks are an important segment in the promotion of gastronomy and thus can influence the development of gastronomy and gastronomic tourism. It is recommended that future researchers see the extent to which each network can individually contribute to the development of gastronomy and tourism itself. Therefore, it is concluded that the correct use of technologies for the purpose of promoting gastronomy can lead to the development of gastronomic tourism itself, because it has been observed that one of the main motives for guests to visit a destination is precisely food and gastronomy. In this sense,

facilities that provide food and beverage services should correctly use technologies, in this context social networks, in order to market their product as well as possible and manage their risks that appear in the business.

## V. CONCLUSION

Gastronomic tourism is now a global trend that is capturing the public's attention. In recent years, social networks have grown in popularity. Similar surveys have been conducted in the Republic of Serbia, where it is claimed that more than half of the respondents in the survey stated that they get information from social networks, and a large number of them get information from online newspapers and portals.

Young people in Serbia mentioned Instagram, Whatsapp, Youtube, and Facebook as the social networks they use the most, with other networks mentioned in a slightly lower percentage, but they certainly visit and use their content. The majority of social network users have high trust in their content. When it comes to social media, tourism and gastronomy are among the most popular blogs.

More than 80% of all tourists begin their journey online. According to statistics, 89% of millennials use social media to research travel, and the information they gather helps them choose their preferred location.

This is difficult because everyone can express their negative opinions on social media. Organizations can benefit from successfully managing their corporate profile/page by resolving potential problems and turning negative opinions into praiseworthy ones.

Quality content loses importance if it is posted in the wrong place and causes a negative reaction from social network users. In accordance with the research and facts presented above, the authors conducted a field study to determine the extent to which and which social networks have the greatest impact on the awareness of gastronomic tourism consumers in Serbia.

The goal of this type of factor analysis was to reduce the number of factors to three so that the impact of these factors on predicting consumer behavior could be easily determined. In this case, the three identified factors were: the impact of word-of-mouth advertising, the impact of social networks, and other marketing methods. The findings revealed that the social network

Instagram, as well as word of mouth, have significant predictive power in predicting consumer behavior when it comes to selecting restaurants and gastronomic offerings.

#### REFERENCES

- [1] Mak, A. H. N., Lumbers, M., Eves, A., & Chang, R.C.Y. (2017). The effects of food-related personality traits on tourist food consumption motivations. *Asia Pacific Journal of Tourism Research*, 22(1), 1-20.
- [2] Vukolić, D., Gajić, T., & Bugarić, J. (2021a). Stavovi lokalnog stanovništva o razvoju turizma u Sremskoj Mitrovici. In *Trendovi u poslovanju, Zbornik radova pete nacionalne naučno stručne konferencije sa međunarodnim učešćem* (pp. 229-309).
- [3] Vukolić, D., Gajić, T., & Bugarić, J. (2021b). Zadovoljstvo gostiju ponudom evropskih internacionalnih jela i proizvoda u restoranima Srbije. *Turističko poslovanje*, 28, 27-38.
- [4] Kukanja, M. & Peštek, A. (2020). Development of Slovenia's Gastronomy – From Peasant Food to the European Region of Gastronomy 2021. Peštek, A., Kukanja, M. & Renko, S. (Ed.) *Gastronomy for Tourism Development*, Emerald Publishing Limited, Bingley, 109-131.
- [5] Mason, M. C., & Paggiaro, A. (2012). Investigating the role of festivalscape in culinary tourism: The case of food and wine events. *Tourism Management*, 33(6), 1329-1336.
- [6] Long M. L. (1998). Culinary Tourism: A Folkloristic Perspective on Eating and Otherness. *Southern Folklore*
- [7] Gajić, T., Popov Raljić, J., Blešić, I., Aleksić, M., Vukolić, D., Petrović, M.D., Yakovenko, N.V., & Sikimić, V. (2021). Creating Opportunities for the Development of Craft Beer Tourism in Serbia as a New Form of Sustainable Tourism. *Sustainability*, 13(16), 8730.
- [8] Yu, C. E., & Sun, R. (2019). The role of Instagram in the UNESCO's creative city of gastronomy: A case study of Macau. *Tourism Management*, 75, 257-268.
- [9] Cvetkovski, T., Langović-Miličević, A., & Babić, S. (2015). Primena društvenih mreža u regrutovanju kandidata za upražnjena radna mesta. *Godišnjak Fakulteta za kulturu i medije: komunikacije, mediji, kultura*, 7, 289-304.
- [10] Djafarova, E., & Rushworth, C. (2017). Exploring the credibility of online celebrities' Instagram profiles in influencing the purchase decisions of young female users. *Computers in Human Behavior*, 68, 1-7.
- [11] Wally, E., & Koshy, S. (2014). The use of Instagram as a marketing tool by Emirati female entrepreneurs: An exploratory study. In *29th International Business Research Conference* (pp. 1-19).
- [12] Horng, J., & Tsai, C. (2010). Government websites for promoting East Asian culinary tourism: A cross-national analysis. *Tourism Management*, 31(1), 74-85
- [13] Kaplan, A. M. & Haenlein, M. (2010). Users of the world, unite! the challenges and opportunities of social media. *Business Horizons*, 53(1), 59-68.
- [14] Filo, K., Lock, D. & Karg, A. (2015). Sport and social media research: a review. *Sport Management Review*, 18(2), 166-181.
- [15] Obar, J. A. & Wildman, S. (2015). Social media definition and the governance challenge: an introduction to the special issue. *Telecommunications Policy*, 39(9), 745-750.
- [16] Goffman, E. (1959). *The Presentation of Self in Everyday Life*. Doubleday, Garden City, NY.
- [17] Buoincontri, A. Morvillo, F. Okumus, & M. van Niekerk (2017). Managing the experience co-creation process in tourism destinations: Empirical findings from Naples. *Tourism Management*, 62, 264-277.
- [18] Fatanti, M. N., & Suyadnya, I. W. (2015). "Beyond User Gaze: How Instagram creates tourism destination brand?". *Procedia - Social and Behavioral Sciences*, 211, 1089-1095.
- [19] Prahalad, C. K., & Ramaswamy, V. (2004). Co-creation experiences: The next practice in value creation. *Journal of Interactive Marketing*, 18(3), 5-14.
- [20] Doolin, B., Burgess, L., & Cooper, J. (2002). Evaluating the use of the web for tourism marketing: A case study from New Zealand. *Tourism Management*, 23(5), 557-561.
- [21] Zadeh, A. H., & Sharda, R. (2014). Modeling brand post popularity dynamics in online social networks. *Decision Support Systems*, 65, 59-68.
- [22] Swani, K., Milne, G. R., Brown, B. P., Assaf, A. G., & Donthu, N. (2017). What messages to post? Evaluating the popularity of social media communications in business versus consumer markets. *Industrial Marketing Management*, 62, 77-87.
- [23] De Vries, L., Gensler, S., & Leeflang, P. S. (2012). Popularity of brand posts on brand fan pages: An investigation of the effects of social media marketing. *Journal of Interactive Marketing*, 26(2), 83-91.
- [24] Sabate, F., Berbegal-Mirabent, J., Cañabate, A., & Lebherz, P. R. (2014). Factors influencing popularity of branded content in Facebook fan pages. *European Management Journal*, 32(6), 1001-1011.
- [25] Sevin, H. E. (2014). Understanding cities through city brands: City branding as a social and semantic network. *Cities*, 38, 47-56
- [26] Chen, N. (2012). Branding national images: The 2008 Beijing summer olympics, 2010 Shanghai world expo, and 2010 Guangzhou asian games. *Public Relations Review*, 38(5), 731-745.
- [27] Lai, M. Y., Khoo-Lattimore, C., and Wang, Y. (2018). A perception gap investigation into food and cuisine image attributes for destination branding from the host perspective: The case of Australia. *Tourism Management*, 69, 579-595.
- [28] Ab Karim, S., & Chi, C. G. Q. (2010). Culinary tourism as a destination attraction: An empirical examination of destinations' food image. *Journal of Hospitality Marketing & Management*, 19(6), 531-555.
- [29] Fields, K. (2002). Demand for the gastronomy tourism product: Motivational factors. *Tourism and gastronomy*, Routledge (pp. 50-64).
- [30] Kim, Y., Eves, A., & Scarles, C. (2009). Building a model of local food consumption on trips and holidays: A grounded theory approach. *International Journal of Hospitality Management*, 28(3), 423-431.
- [31] Yuan, Y., Chan, C. S., Eichelberger, S., Ma, H., & Pikkemaat, B. (2022). The effect of social media on travel planning process by Chinese tourists: the way

- forward to tourism futures. *Journal of Tourism Futures* (pp. 1-20).
- [32] Dossena, C., Mochi, F., Bissola, R., & Imperatori, B. (2021). Restaurants and social media: rethinking organizational capabilities and individual competencies. *Journal of tourism Futures*, 7(1), 20-39.
- [33] Jiménez Beltrán, J., López-Guzmán, T., & Santa-Cruz, F. G. (2016). Gastronomy and tourism: Profile and motivation of international tourism in the city of Córdoba, Spain. *Journal of Culinary Science & Technology*, 14(4), 347-362.
- [34] Zhou, L., & Wang, T. (2014). Social media: A new vehicle for city marketing in China. *Cities*, 37, 27-32.
- [35] Burgess, S., Sellitto, C., Cox, C., & Buultjens, J. (2009). User-generated content (UGC) in tourism: Benefits and concerns of online consumers. In *17th European Conference on Information Systems*.
- [36] Vukolić, D., Gajić, T. & Gamor, E. (2021c). The importance of tourist's perception of restaurant's offer in Banja Luka. In *The Eight International Academic Conference, Banja Luka*, (pp. 401-411).
- [37] Chua, A. Y. K., & Banerjee, S. (2015). How businesses draw attention on facebook through incentives, vividness and interactivity. *International Journal of Computer Science*, 42(3), 275-281.
- [38] Gretzel, U., & Yoo, K. H. (2008). Use and impact of online travel reviews. *Information and communication technologies in tourism* (pp. 35-46).
- [39] Fong, L. H. N., Lei, S. S. I., & Law, R. (2017). Asymmetry of hotel ratings on TripAdvisor: Evidence from single- versus dual-valence reviews. *Journal of Hospitality Marketing & Management*, 26(1), 67-82.
- [40] Mariani, M. M., Di Felice, M., & Mura, M. (2016). Facebook as a destination marketing tool: Evidence from Italian regional destination management organizations. *Tourism Management*, 54, 321-343.
- [41] Taylor, D. G., Lewin, J. E., & Stratton, D. (2011). Friends, fans, and followers: Do ads work on social networks?. *Journal of Advertising Research*, 51(1), 258-275.
- [42] Lin, H., Swarna, H., & Bruning, P. F. (2017). Taking a global view on brand post popularity: Six social media brand post practices for global markets. *Business Horizons*, 60(5), 621-633.
- [43] Bickart, B., & Schindler, R. M. (2001). Internet forums as influential sources of consumer information. *Journal of Interactive Marketing*, 15(3), 31-40.
- [44] Moe, W. W., & Trusov, M. (2011). The value of social dynamics in online product ratings forums. *Journal of Marketing Research*, 48(3), 444-456.
- [45] Drummey, C. (2017). Influencer and Marketing Campaigns on Social Media: Which Platforms to Use and When. *MarketingProfs*, 27.
- [46] Gajic, T., Radovanovic, M., Tretiakova, T., & Syromiatnikova, J. (2020). Creating brand confidence to gastronomic consumers through social networks—a report from Novi Sad. *Journal of Place Management and Development*.
- [47] Bartle, C., Avineri, E., & Chatterjee, K. (2013). Online information-sharing: A qualitative analysis of community, trust and social influence amongst commuter cyclists in the UK. *Transportation Research Part F: Traffic Psychology and Behaviour*, 16, 60-72.
- [48] Kasavana, M. L. (2008). The unintended consequences of social media and the hospitality industry. *Hospitality Upgrade*.
- [49] Buted, R. D., Gillespie, S. N., Conti, B. J., Delgado, A. B., Mae, P. R., Sher, M., Rubico, A. K., & Felicen, S. m Industry of Batangas Province. *Asia Pacific Journal of Multidisciplinary Research*, 2(3), 123-131.
- [50] Vukolic, D., Gajić, T. & Penic, M. (2022). The effect of social networks on the development of gastronomy – the way forward to the development of gastronomy tourism in Serbia. *Journal of Tourism Futures*, Vol. ahead-of-print No. ahead-of-print.

# Analysis of the Influence of Types of Multimedia Content in Posts on Social Networks on the Success of Posting

Đorđe Petrović<sup>1</sup>, Ivan Pantelić<sup>2</sup>, Dejan Beljić<sup>3</sup>

<sup>1,2,3</sup>Valjevo Department, Western Serbia Academy of Applied Studies, Valjevo, Serbia

<sup>1</sup>djordje.petrovic@vipos.edu.rs, <sup>2</sup>ivan.pantelic@vipos.edu.rs, <sup>3</sup>dejan.beljic@vipos.edu.rs

**Abstract**—This paper describes research and analysis of the performance of the services used for promotion, different types of published content, as well as different types of promotional content, and the impact of all of the above on the success of social media posts. The goal of the research is to determine whether it is possible to influence the success of publishing content by managing these values, as well as to obtain data for optimizing content publishing. The research described in this paper can be used for data on the success of posts on social networks, for posts made and published for the needs of any institution or individual.

**Keywords** - social network, multimedia content, success, correlation

## I. INTRODUCTION

According to one of the definitions, the Social Network is a communication over the Internet, in which more than one user publish information within a community of users [1]. Some of the authors go even further, claiming that e.g. Facebook enables the most effective communication on the Internet [2]. Essentially, Social Networks are a modern and indispensable tool for promotion and advertising of both products and services, and perhaps even the best tool for that purpose. In this research, the use of social networks by the observed educational institution will be analyzed, so the activities of this institution on social networks will be treated as promotion and advertising of services. By their very nature, social networks represent the application of web technologies in creating virtual communities with users of posts and other content, and provide useful data about the activities of those users. In addition to providing

useful data about users, they also enable the analysis of that data in order to increase the number of users and improve their interaction with published content. Thus, the goal of this research is to analyze the impact of different types of posts, different types of published content, as well as different types of promotional content, on the reactions of users of social networks, in order to determine whether the management of these values can increase the reach and number of users of published content. The innovative approach of this research, in relation to other analyzes of such data, is that the posts are classified by the type of post and the type of content of the post, and then is analyzed the impact of certain types of posts and types of post content on the reach of those posts. In addition, this analysis can eventually provide useful data for assessing threats to the effect that is intended to be achieved by publishing content on social networks.

## II. RELATED WORKS

Research on the effects of promotion on social networks covers a wide range of topics and applications of different methodological disciplines. There are a number of works that have dealt with the analysis of content published on various social networks from the aspect of content-related parameters. One such work is [3]. In the research of feedback received from social networks, the authors [4] showed the effects of the reactions of social network users on the benefit that arose and was accumulated from the relationship with those users. In a study that analyzed data on the reactions of social network users to the publication of educational content [5]

it was shown that such data offer a wealth of opportunities for researchers interested in social media analytics. In addition, we have witnessed significant changes in the structure and way of organizing global social networks in the past year. In October 2021, social networks Facebook and Instagram were merged into the company brand “Meta” [6], and in 2022, Elon Musk bought and took over Twitter, which heralded a new era in functioning and the way of promotion on social networks. All of the above just indicates that it is necessary to conduct research, such as the one described in the rest of this paper.

### III. DESCRIPTION OF THE DATA

In this research, in an innovative way data were analyzed on the reactions of visitors to social networks to posts that were made and published for the needs of the Department in Valjevo, Western Serbia Academy of Applied Studies. The data, which were analyzed, were collected for a period of one year. As the data refer to an educational institution, they were collected for the period of one academic year, so they cover the period from October 1, 2021 to September 30, 2022. Data on the reactions of visitors to the social networks Facebook and Instagram, and to different types and types of posts, were analyzed. Specifically, after downloading the data, it was determined that during that period the observed educational institution published 1094 announcements on these social networks. For each of the announcements, the following data were analyzed that indicate the success of the observed announcements:

- Reach – Reach refers to the number of unique users of social networks, who saw some content on their screen;
- Likes and reactions – user interactions on posts, by clicking on one of the offered options for likes and other reactions;
- Sticker taps – the number of users who clicked on the sticker;
- Replies – the number of responses to a post;
- Link clicks – the number of users who clicked on the offered link;
- Comments – the number of users who commented on the posts;

- Shares – the number of users who shared the post publicly on another location.

During the further analysis of the collected data, the distribution of announcements was first made in relation to different types of announcements, to different types of published content, as well as to different types of promotional content. The distribution of services and types of posts is given in Table I. The distribution of the type of multimedia content that was used for posts, for the observed set of posts, is given in Table II. The distribution of the method of publication of multimedia content, whether or not they contain a textual explanation in the publication, for the observed set of publications is given in Table III. The distribution of promotional and informational content, which were used for announcements, for the observed set of announcements is given in Table IV.

TABLE I. SOCIAL NETWORKS AND TYPES OF POSTS

Social network	Post type	Post participation
Instagram	Story	46.16%
Facebook	Post	26.42%
Instagram	Post	24.86%
Facebook	Story	2.56%

TABLE II. TYPE OF CONTENT IN POSTS

Content type	Post participation
A graphic visual, drawing or image	52.22%
Photo	33.61%
Link	7.91%
Scanned material	5.93%
Video	0,33%

TABLE III. TEXT EXPLANATIONS IN POSTS

Content type	Post participation
Multimedia content with accompanying text	70.41%
Multimedia content without accompanying text	29.59%

TABLE IV. POST CONTENT

Post content	Post participation
Events related to the institution and promotion of the institution	49,75%
Primary activity of the institution, information about studies and students	44.50%
General information, holiday greetings, etc.	4.06%
Information about external events, events in other institutions, etc.	1.69%

#### IV. DATA ANALYSIS

In this analysis, data on the interaction of social network users on individual posts will be observed, only for posts for which no promotion has been paid. Calculated degrees of correlation, observed parameters and their influence on certain reactions of users of social networks are given in the following tables.

The following table (Table V) shows the results obtained for the correlation coefficients of the services used and individual reactions of users of social networks. "Stories on Facebook" are excluded from the results shown, due to the small sample, i.e. due to the small number of these posts in the observed period.

TABLE V. CORRELATION COEFFICIENTS OF THE SERVICE USED AND INDIVIDUAL REACTIONS OF USERS OF SOCIAL NETWORKS

	Reach	Likes and reactions	Sticker taps	Replies	Link clicks	Comments	Shares
Facebook Post	<b>0.39</b>	-0.07	-0.10	-0.09	<b>0.27</b>	0.19	-0.09
Facebook Story	-	-	-	-	-	-	-
Instagram Post	<b>-0.21</b>	<b>0.29</b>	-0.09	-0.08	<b>-0.22</b>	-0.14	0.18
Instagram Story	<b>-0.27</b>	<b>-0.33</b>	<b>0.30</b>	<b>0.27</b>	-0.09	-0.07	-0.14

Table VI shows the results obtained for the correlation coefficients of the type of multimedia content and individual reactions of users of social networks. Videos are excluded from the displayed results, due to the small sample, that is, due to the small number of these announcements in the observed period.

Table VII shows the results obtained for the correlation coefficients of the type of published content and individual reactions of users of social networks. "Information on external events" is excluded from the displayed results, due to the small sample, that is, due to the small number of these announcements in the observed period.

TABLE VI. CORRELATION COEFFICIENTS OF CONTENT TYPE AND INDIVIDUAL REACTIONS OF USERS OF SOCIAL NETWORKS

	Reach	Likes and reactions	Sticker taps	Replies	Link clicks	Comments	Shares
Photo	0.16	<b>0.37</b>	0.01	0.05	-0.07	0.09	0.12
Graphic	-0.12	<b>-0.30</b>	0.03	-0.01	-0.09	-0.08	-0.03
Scanned material	0.01	-0.03	-0.03	-0.03	-0.07	-0.02	-0.09
Link	-0.07	-0.08	-0.03	-0.03	<b>0.35</b>	0.00	-0.06
Video	-	-	-	-	-	-	-
Following text	0.18	0.19	-0.02	-0.03	-0.06	0.05	0.02

TABLE VII. CORRELATION COEFFICIENTS OF THE TYPE OF CONTENT AND INDIVIDUAL REACTIONS OF USERS OF SOCIAL NETWORKS

	Reach	Likes and reactions	Sticker taps	Replies	Link clicks	Comments	Shares
Events	-0.04	0.00	0.10	0.07	-0.04	-0.04	-0.05
General information	-0.07	-0.08	-0.02	-0.02	0.01	-0.03	-0.08
Studies and students	0.08	0.04	-0.09	-0.06	0.04	0.06	0.09
External events	-	-	-	-	-	-	-



## V. DISCUSSION

The interpretation of the obtained results is often based on the interval in which the values for the correlation coefficient are found, such as e.g. shown in the paper [7]. Based on the results obtained from the research of the observed data set and in accordance with the interpretations described in the previous work, it can be concluded that in this data set there are no high values for the degree of correlation of the observed values with the reactions of social network users.

Regarding the service used for promotion, the highest value obtained is 39% for the impact of a post on the social network Facebook on the reach of those posts, and this value can be interpreted as a weak correlation. Slightly lower values were obtained for Instagram stories, which have a positive correlation with user clicks on stickers, then Instagram posts, which have a positive correlation with user interactions on those posts, etc.

On the other hand, negative values were observed for the correlation of stories on the social network Instagram to the user interactions on posts and to the reach of those posts, as well as for the correlation of posts on Instagram to the number of users who clicked on the offered link and to the reach of those posts. Although these values show little correlation with user reactions, this phenomenon may be the subject of some special research and determining potential threats from such posts, to the effect that is intended to be achieved by publishing content on social networks.

As for the obtained results for the correlation of certain types of published content with the reactions of social network users, the range of obtained values is similar to the correlation values for the types of published content. The highest value is 37% for the influence of published photos on the interaction of social network users on posts. One of the expected results refers to the correlation value between links in posts and the activity of social network users, which measures the number of clicks on the offered link.

On the other hand, the subject of some further research may be obtained negative values for the correlation of graphic posts on user interaction with such posts and determining the cause of this phenomenon.

Apart from the previously described results, all obtained values for the degree of correlation of the influence of certain types of content on the reactions of users of social networks are close to zero, so it can be concluded that there is no connection between the types of content and their success on social networks.

## VI. CONCLUSION

The results obtained in this research do not show a strong connection between the observed data on services, types and types of content and data that indicate the success of individual posts on social networks. Based on the obtained results, as well as on the basis of the observed isolated set of data, it is not possible to make general conclusions. The obtained results can still be interpreted and used to improve the effects of the promotion.

The use of certain services for promotion and types of posts, which have positive values for correlation, can be used to a greater extent for communication with users of social networks. On the other hand, you should pay attention to the services and types of posts that have a negative correlation with the interaction of users of social networks and make changes in the use of such posts.

The analysis described in this research can be used to analyze data on the success of posts on social networks, for posts made and published for the needs of any institution or individual.

## REFERENCES

- [1] Luchman, J., & Romano Bergstrom, J., & Moynihan, C. (2014). A motives framework of social media website use: A survey of young Americans. *Computers in Human Behavior*, 38, 136–141.
- [2] Smith, S. D., & Caruso J. B. (2010). ECAR Study of Undergraduate Students and Information Technology, 2010 (Research Study). *ECAR Research Study*, 6.
- [3] Jothi, P. S., Neelamalar, M., & Prasad, R. S. (2011). Analysis of social networking sites: A study on effective communication strategy in developing brand communication. *Journal of Media and Communication Study*, 3(7), 234-242.
- [4] Varanasi R. A., Diccico, E., & Gambino, A. (2018). Facebook Reactions: Impact of Introducing New Features of SNS on Social Capital. In *International Conference of Human-Computer Interaction* (pp. 444-451).
- [5] Freeman, C., Roy, M. K., Fattoruso, M., & Alhoori, H. (2019, June). Shared feelings: Understanding facebook reactions to scholarly articles. In *2019 ACM/IEEE Joint Conference on Digital Libraries (JCDL)* (pp. 301-304). IEEE.

- [6] Kraus, S., Kanbach, D. K., Krysta, P. M., Steinhoff, M. M., & Tomini, N. (2022), Facebook and the creation of the metaverse: radical business model innovation or incremental transformation? *International Journal of Entrepreneurial Behavior & Research*, 28(9), 52-77.
- [7] Napitupulu, D., et al. (2018). Analysis of Student Satisfaction Toward Quality of Service Facility. *Journal of Physics Conference Series*, 954(1).



# Education and Knowledge about Sustainable Development Goals

Milica Stanković<sup>1</sup>, Jovana Džoljić<sup>2</sup>, Tiana Anđelković<sup>3</sup>, Suzana Stojković<sup>4</sup>

<sup>1,2,3,4</sup>Academy of Applied Technical and Preschool Studies, Vranje, Serbia

<sup>1</sup>milica.stankovic@akademijanis.edu.rs, <sup>2</sup>jovana.dzoljic@akademijanis.edu.rs,  
<sup>3</sup>tiana.andjelkovic-vr@akademijanis.edu.rs, <sup>4</sup>suzana.stojanovic@akademijanis.edu.rs

**Abstract**—The concept of sustainable development is an extremely popular topic. Sustainable development was talked about even before 1992, when UNESCO decided to promote education for sustainable development. This program was implemented from 2005 to 2014. In 2015, the Agenda for Sustainable Development 2030 was adopted. The goals of sustainable development represent environmental, social, and economic requirements that need to be met in the future. It is necessary to influence people to focus on learning and acquiring knowledge to broaden their horizons and their awareness of the importance of sustainable development goals. Education and knowledge are included in goal 4, according to which it is necessary to ensure quality and inclusive education for all and lifelong learning for all. The aim of this paper is to point out the importance of lifelong learning in accordance with the concept of sustainable development. The work consists of six parts. The first part will discuss the importance of sustainable development in the 21st century. The importance of intellectual capital will be discussed in the second part of the paper. In the third part, the reasons for improving the educational process will be discussed. The fourth part will talk about the carriers of changes in the educational process. Through the fifth part of the paper, the urgency of implementing the goals from the 2030 Agenda will be pointed out, and through the sixth part, the influence of knowledge and education on the goals of sustainable development will be discussed.

**Keywords** – sustainable development goals, knowledge, education

## I. INTRODUCTION

Quality education is the basic postulate of the progress of society. With the possibility of educating more people on the planet, their

knowledge about phenomena in nature and society began to spread. They became more aware of the problems we face as a society and began to think about sustainable development. Sustainable development is not only the development that is expressed by economic indicators, such as growth in production, increase in productivity, decrease in unemployment, gross domestic product, but also integrates social and environmental components. Therefore, in addition to economic problems, it is necessary to pay attention to social and environmental problems as well. For us as a society to survive if possible, it is necessary to pay attention to environmental problems and to solve them continuously, but also to continuously take care of people's living standards and economic variables. To deal with these and other current problems of sustainable development, it is necessary to acquire new knowledge and skills, to transform the educational system, so that after the completion of formal education, graduates will have the skills needed for a new era, the era of sustainable development.

The 2030 Agenda for Sustainable Development, which was adopted in 2015 at the United Nations General Assembly, promotes sustainable development goals that should be achieved by 2030 [1]. This global framework of sustainable goals was established after the United Nations Conference on Sustainable Development, held in Rio de Janeiro, which was attended by the member countries of the United Nations, as well as other interested countries. At the heart of this Agenda are the 17 Sustainable Development Goals that describe the main challenges for humanity - which is to enable everyone to live a sustainable, peaceful,

prosperous, and just life now and in the future. It is about global challenges that are crucial for the survival of humanity. To realize them in the planned period, we need to focus as much as possible on education and knowledge. Intellectual capital is the basic factor of economic and economic growth, but obviously also the driving force of sustainable development.

## II. THE IMPORTANCE OF SUSTAINABLE DEVELOPMENT IN THE XXI CENTURY

For the first time, sustainable development was discussed almost 30 years ago, back in the nineties of the 20th century, when Agenda 21 was adopted at the Earth Summit - the United Nations conference on environment and development, which spoke about it. In the meantime, numerous scientific research has been carried out and numerous publications have been published, but the number of problems that must be solved has also increased. The public has also become more aware of the problems facing the world. During 2012, a conference was held, because the difficulty of certain countries to implement the goals of sustainable development from 1992 was recognized.

The reasons for this non-implementation of the goals of sustainable development by certain countries lie in the insufficient progress and even backwardness of those countries regarding the dimensions of sustainable development (economic, ecological, social). The response of the international community to this problem was the establishment of the United Nations Forum on Sustainable Development (High level political forum - HLPF). The main task of this body was to strengthen science for better political influence to achieve the goals of sustainable development even in the most underdeveloped countries [2].

The 2014 Global Sustainable Development Goals Report tells us about the founding of the science of sustainable development [3]. The field of research in the science of sustainable development is defined as research into the relationship between natural and social phenomena and their impact on the survival and development of humanity. One of the main characteristics of the science of sustainable development is its integration - that it incorporates multiple natural and social sciences and seeks a constant balance between multiple conflicting goals. The idea is to bring together experts from different fields related to sustainable development, who will jointly define

the problems of sustainable development and develop methodologies for solving those problems [4]. In addition to hiring experts from the fields of economics, ecology, biology, psychology, sociology, it is often necessary to hire engineers and mathematicians who would use their technical and mathematical knowledge to identify the main variables and limitations and apply some of the optimization methods [5].

In September 2014, 17 sustainable development goals were proposed, as well as 169 intermediate goals that should be achieved by 2030. They are defined as the goals of the universal political aspiration to achieve sustainable development in both developed and underdeveloped countries. These goals set ecological limits for the use of natural resources. Ending poverty is also one of the main goals and it should be achieved in parallel with economic development. The goals of sustainable development also include improving the satisfaction of social needs through the improvement of health, education, social protection, and employment. They relate to both climate change management and environmental protection. Therefore, the goals of sustainable development focus on solving problems such as inequality, irrational use of natural resources, environmental degradation, lack of economic growth. In order to achieve these goals, each of us should do our part - governments to establish national frameworks, policies and measures for the implementation of Agenda 2030, the private sector to employ minorities, women, young people, regularly pay taxes, fees, salaries and other duties, to exploit natural resources and pollute the environment as little as possible, and all of us as members of society to behave rationally and responsibly [6].

Now we are already at the end of 2022. The world continues to face crises that threaten to destroy humanity's survival on Earth. The 2022 Sustainable Development Goals report shows progress. However, due to the many crises that have befallen our planet in the past and are still ongoing, such as the pandemic caused by the Covid-19 virus, war conflicts in Ukraine, climate change and others, we come to a situation where we wonder if we are on the right path to achieving the goals of sustainable development. For example, the pandemic caused by the Covid-19 virus has pushed more than 93 million people into extreme poverty [7]. The increase in the number of extremely poor people has led to the disruption of the provision of health services,

which has resulted in a decrease in the percentage of people who are vaccinated not only against the Covid-19 virus but also against other long-eradicated diseases. Schools and universities around the world were closed during 2020, and during 2021 and partially during 2022, classes were held online, so there were numerous educational failures. The consequences of that will be felt only in a few years. There is also climate change, which has remained in the shadow of these crises. Floods, droughts, heat waves, unstoppable fires affect people all over the world more and more every year and cause enormous damage to the planet's ecosystem. In terms of conflict, it is believed that as much as a quarter of the global population today lives in countries where war conflicts prevail. War conflicts in Ukraine caused a jump in the prices of basic foodstuffs and oil, supply chains and the financial market were disrupted. All these developments also led to the growth of inflation, especially in countries in transition that are unsuccessfully trying to deal with the consequences of these crises [7].

There are obviously many problems and obstacles on the way to sustainable development. That is why it is necessary to systematically solve one problem at a time and gradually eliminate obstacles to return to normal as soon as possible and continue to achieve the goals of sustainable development. An extremely important factor in this process is knowledge, but also education. This two-year intermezzo did cause the degradation of knowledge and education systems everywhere in the world. For humanity to survive, we must deal with the issues of spreading knowledge and creating such an educational system that will produce experts who will successfully deal with issues and problems of sustainable development.

### III. THE IMPORTANCE OF KNOWLEDGE AND INTELLECTUAL CAPITAL IN MODERN SOCIETY

To deal with issues of sustainable development, it is necessary to have appropriate knowledge. Dealing with these issues means possessing knowledge, skills, abilities, but also attitudes that will further empower people to deal with these important issues.

We are witnessing the rapid progress of technology and its penetration into all spheres of life and economy. All this trend of digitization and globalization leads to the fact that we work and live in increasingly uncertain circumstances, where social diversities are manifested. This

results in an increase in people's economic and cultural awareness on the one hand, but on the other hand it also leads to greater vulnerability of vulnerable categories of the population and disruption of the ecological balance. The problem arises because people find it increasingly difficult to understand the world in which they live and work. That is why it is necessary to educate ourselves in accordance with the problems we are facing, which are certainly the growing social inequality, the problem of using non-renewable natural resources, but also other environmental problems. People who can talk about these problems of sustainable development today, to solve them and to work towards achieving the goals of the 2030 Agenda, we call "sustainability citizens" [8]. You so called "Citizens of sustainability" must have competences that will enable them to behave responsibly and competently for the purpose of sustainable development.

Competences are all those characteristics of individuals that enable them to deal with some issues willingly, consciously, and qualitatively. These are not the knowledge that is acquired in the process of formal education, but the knowledge that develops in the consciousness of everyone. They are acquired experientially, but also because of the thinking process [9]. Key competences in terms of the concept of sustainability represent the abilities of "sustainable citizens" to cope with today's complex challenges that coincide with the goals of sustainable development. Such competences enable the various goals of sustainable development to be interconnected, so that individuals dealing with these issues have a broader view of the situation.

According to the results of the research conducted in Malaysia on how students are familiar with the concept of sustainable development, we learned the following data. In general, students show a low level of knowledge about this concept [10]. Students have only basic knowledge about the problems of sustainable development that the whole world is facing, and they cite structural deficiencies in the education system as the reason for this. Lower education and the highest tertiary level of education are considered the best platform for promoting awareness of sustainable development goals [11]. The knowledge that young people acquire about sustainable development is mainly from traditional mass and social media such as

newspapers, television, radio, and social networks, but increasingly modern communication channels such as YouTube, Tweeter and Instagram. These more modern channels are increasingly in use, so authorities dealing with sustainable development goals should use them to spread knowledge about the sustainable development problems we face.

#### IV. EDUCATION AS A FACTOR OF GROWTH OF KNOWLEDGE AND INTELLECTUAL CAPITAL

New education programs should contribute to the fact that graduates can bring the so-called informed decisions and actions that will contribute to achieving the goals of sustainable development. The concept of sustainable development must therefore be permeated through all levels of education - from the preschool educational program, all the way to the highest level of education. Such a "new education" that requires the concept of sustainable development does not only mean that during classes one learns about climate change, about poverty, or about the use of non-renewable resources, but it implies a new - higher level of education and learning. This means that the entire educational process needs to be transformed, in order to avoid dry learning and repetition of what has been written, and to enable pupils and students to draw their own conclusions based on given facts and circumstances. In this way, it will not only lead to the establishment of the concept and realization of the goals of sustainable development, but also to the development of civilization itself in general.

Developing new teaching and educational programs that support the development of cognitive, socio-emotional, and behavioral learning outcomes as well as key competencies related to sustainable development will certainly lead to the achievement of the goals of the 2030 Agenda and to general social well-being. However, to achieve this easier and faster, it is necessary to ensure the support of politics - ministries in charge of education, science. They have an important role in terms of adapting the curriculum and processes to the new challenges of sustainability. This process is still ongoing in many countries, but it is still very uneven.

If we look at the education sector, we cannot ignore the teaching staff, which is the key driver of changes that can provide the opportunity to achieve the goals of sustainable development. The knowledge and competences of teachers are

essential for the restructuring of educational processes and educational institutions towards the concept of sustainability. Continuous education of the teaching staff is necessary so that they can convey appropriate knowledge to pupils or students in the right way. Given that this is an ongoing process, the results so far have shown that the support of the teaching staff was crucial for the successful inclusion of the concept of sustainable development in the teaching process. Unfortunately, it is still not enough. It is necessary to work more on the implementation of the concept of sustainable development, that is, it is considered that the current teachers are not sufficiently prepared for the restructuring of the teaching process in this direction because they themselves do not have sufficient and necessary knowledge and experience. What they certainly lack is the ability to help people develop sustainability competencies through different models of innovative learning.

In the literature, there are different conceptual frameworks of teacher competencies in the field of sustainable development, such as the CSCT model [12], the UNECE model [13], the KOM-BiNE model and other models. Therefore, to implement the concept of sustainable development in the curriculum itself, it is necessary to deal with the initial and professional education of teachers. In addition to the theoretical concept of sustainable development that they must know, teachers also learn based on real social challenges in the local, national, and global context, so this requires cooperation with all parties involved in this concept. This process includes the internationalization of this problem to expand the base of necessary knowledge and skills of both teachers and students at international conferences, but also through student exchanges.

#### V. THE MAIN CARRIERS OF CHANGES IN EDUCATION

It is necessary to start from the policy makers in each country individually. The state, i.e. policy holders in a state, are extremely important in creating an environment for the successful dissemination of knowledge and importance of solving the problem of sustainable development. The state is key in the process of making decisions about changing curricula in accordance with the goals of sustainable development. Therefore, it is not just one person like the president of the state or the prime minister who is crucial for the implementation of these goals.

The ministry of education, at the local and national level are also important. It is necessary to point out the importance of employees in the ministries for environmental protection and other ministries dealing with issues of sustainable development. As representatives of the state, there are also academic communities that greatly contribute to the achievement of the goals of sustainable development in terms of education and knowledge, as well as UNESCO and its branches in various countries. Their main tasks would be to define new learning goals that are fully in line with the goals of sustainable development; integrating the concept of sustainable development into the education system; to strengthen relations between formal, non-formal and informal education with their actions and measures [14].

Our future is certainly current students and pupils, so it is necessary to talk about them as agents of change in terms of education and knowledge in terms of achieving the goals of sustainable development. During their life and education, pupils and students acquire knowledge, competences, values, and attitudes to undertake all initiatives and actions towards the achievement of the goals of sustainable development. They are guided on this path by their teachers, teachers, parents, UNESCO and its partners, the wider social and political community [14].

Teachers are still the leading actors who implement innovations in the education process and thus create a new knowledge base to pass on to their students. Teachers help students understand the goals of sustainable development and motivate them to transform themselves and their attitudes to make a positive impact on society. For this purpose, teachers must possess

adequate knowledge, skills, values and attitudes in order to make this transition process as easy as possible. This also implies understanding the key aspects of all 17 sustainable development goals and their interrelationships [14].

Today’s youth, as well as future generations, are the interest group that benefits the most from the fight for sustainable development. That is why they should become as active as possible, but also louder in terms of achieving the goals of Agenda 2030. They should advocate for solving problems related to sustainable development, but especially for climate change and reducing the gap between the poor and the rich. In addition, young people are a very important consumer group, and the formation of their consumer habits today can have a very positive impact on the achievement of sustainable development goals in the future [14].

As we can see in Fig. 1, teachers and other staff employed in schools and universities have a share of as much as 53% in the process of implementing knowledge about sustainable development. After them are the pupils themselves - students and student organizations with 20% participation, and then other associations [15].

VI. SUSTAINABLE DEVELOPMENT – WHERE ARE WE NOW?

The situation we are in now is a direct consequence of human behavior. Reckless human activity has led to climate change, excessive consumption of non-renewable natural resources, but also to stratification of people into extremely rich or extremely poor. Given that we face the consequences of irresponsible human behavior every day, the question arises whether people will ever be

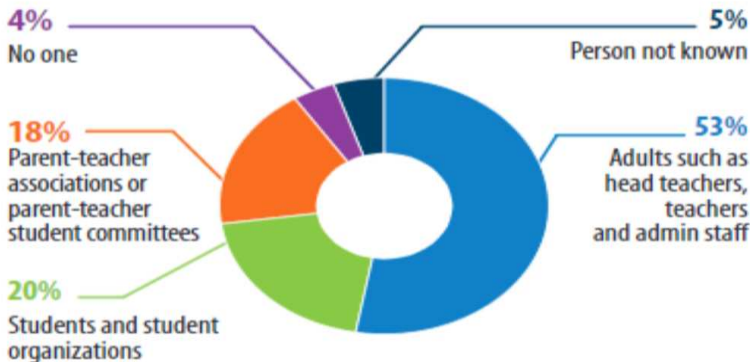

Figure 1. Carriers of education process of the education process to implement the SDGs.



aware that their actions are destroying the possibility of humanity’s long-term survival?

Climate change represents an extraordinary threat to the survival of humanity. The Paris Agreement that was adopted in December 2015, whose task is to make efforts to limit the global temperature increase [16], speaks about this. This agreement has been adopted by as many as 195 countries of the world. The International Panel on Climate Change warns that the effect of global warming is rapidly approaching the 1.5°C level. Predictions are that the effect of global warming of 2°C is catastrophic, and accordingly, rapid, far-reaching changes in all aspects of society are necessary, to keep the effect of global warming at the level of up to 1.5°C (The International Panel on Climate Change [17]). The situation becomes even more dramatic if you consider that before 1975 the effect of global warming was at the level of about 0.5°C, and in 2017 it was at the level of about 0.87°C (±0.12°C) (Fig.2). It is thought that the global increase in temperature from the pre-industrial period to today is already 1°C. If this rate continues, it is thought that by 2040 the world will reach a global warming effect of 1.5°C. When it comes to the period of pre-industrialization, it is not precisely defined in the IPCC report, but it is the period before the beginning of the industrial revolution. Considering that the global temperature increase is decreasing more and more as we go back in time, it is necessary to roughly define the period when the global temperature increase begins to be observed. Therefore, in the IPCC report, that

time is roughly given as the second half of the XIX century.

Once we have defined the pre-industrial period, the next step is to calculate the global warming at any time relative to the base period. Through this IPCC report, global warming is defined as the increase in temperature over a thirty-year period as the average of the combined air temperature over land and water temperature on the ocean surface. A period of 30 years is taken to account for the period of natural variability that can cause different temperatures in the current year compared to the previous year.

In the period from 2006-2015. year, global warming, as we can see on the graph, reached a level of 0.87°C, (±0.12°C) in relation to the pre-industrial period and that is due to human activities. As the decade-long increase in temperature is already around 0.2°C (±0.1°C), the warming of the planet has already reached 1°C around 2017 and if this continues, it will be at the level of 1.5°C in 2040 [17].

This is a global analysis, but it does not mean that all corners of the world emit the same amount of carbon into the atmosphere and that everyone should apply drastic measures to reduce the temperature. In fact, many regions and countries have already exceeded 1.5°C compared to the pre-industrial period. Therefore, special attention should be paid to those regions, to keep the overall effect of global warming at a sufficiently low level.

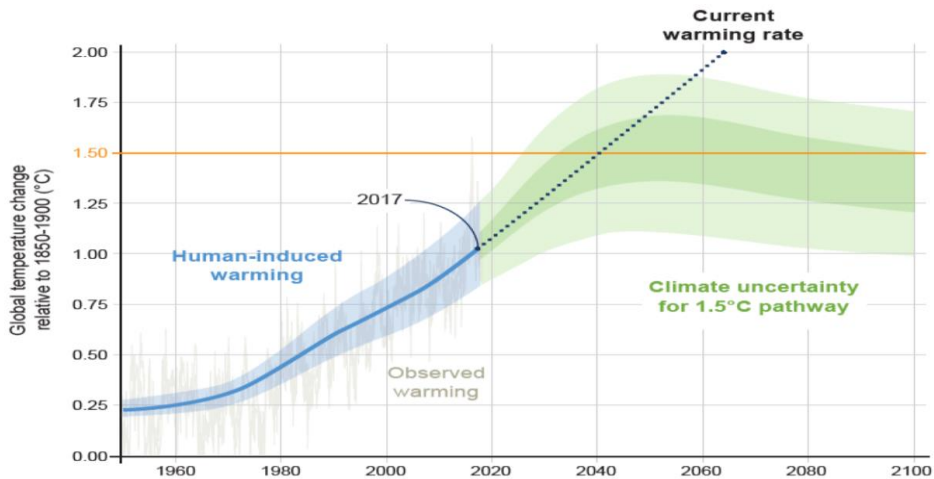

Figure 2. The effect of global warming.

It follows from this that it is necessary to reorient ourselves to new concepts of education in order to take control of this problem as soon as possible, and to reduce the effect of global warming, that is, to keep it under control. In this sense, we need to develop knowledge, skills and attitudes that will enable us all to make informed decisions and to undertake both individual and collective actions at the local, national, and global level. Education for sustainable development is therefore a well-designed concept that empowers pupils and students to make informed decisions about environmental issues, economic prosperity, and social equality. It is a lifelong learning process.

#### VII. THE INFLUENCE OF KNOWLEDGE AND EDUCATION ON THE CONCEPT OF SUSTAINABLE DEVELOPMENT

The aim of these interventions in education is precisely to develop a critical awareness of the complexity of global challenges such as poverty, injustice, and unsustainability. They involve pupils and students getting involved in considering different perspectives, questioning attitudes and prejudices, and thinking about their own roles in maintaining an unbalanced world. The central theme of these changes in education is the development of solution-oriented skills such as critical and creative thinking and constant review of decisions in terms of sustainable development for the survival of the planet [18].

Education based on sustainable development does not only mean that students acquire the necessary knowledge related to sustainable development. The emphasis is on schools and universities, which should orient all their processes towards the principles of sustainability [6]. For the process of implementing the concept of sustainable development to be successfully implemented, it is necessary to transform educational institutions. It is a holistic approach that aims to introduce sustainability in all aspects of the educational institution's operations. This implies a review of the curriculum, campus work, organizational culture, student participation [19]. Only in this way that educational institution will serve as an example for students. The creation of such eco-schools or green campuses will enable students and teachers to accept the goals of sustainable development in their daily lives and thus develop the required competencies in

accordance with the concept of sustainable development.

Given that the transformation of the entire educational institution is important, the Global Action Plan calls on all schools and universities to promote and implement the concept of sustainable development in their work. Considering the existing positive experiences, it is necessary to include lower levels of education, such as preschool institutions, in this transformation program.

#### VIII. CONCLUSIONS

If we consider the growth rate of the effect of global warming in the last 50 years, as well as the increasing inequality between the extremely rich and the extremely poor, it is clear to us that urgent action is necessary in terms of harmonizing the goals of economic and economic growth of each country with environmental and social goals. We treat these three groups of mutually conflicting goals as sustainable development goals defined by Agenda 2030. To achieve these goals, it is necessary to upgrade ourselves as conscious and intellectual beings. Only then can we tackle the problem of sustainable development.

Uncertainty is our everyday life and accordingly, the intellectual capital, i.e. the knowledge and skills we possess, becomes the main resource of any organization. It was finally realized that without people there is no profit or economic growth, but at the same time people are the main culprits for the environmental and social problems we are facing. That's why it is necessary to activate everyone - from the state and its organs, through teachers, all the way to families, non-governmental organizations, local communities, and international organizations to face the problems of sustainable development that we as humanity are already facing in time.

For this purpose, it is necessary to work on redefining the education system in each country, to work on the creation of those knowledge and skills that are necessary in looking at the problems of sustainable development. Only in this way will people become more aware of the problems the whole world is facing and will be able to act to realize the goals of the 2030 Agenda. Precisely for this reason, it is vitally important to include in the teaching process contents related to the goals of sustainable development, but also to use the so-called action-oriented pedagogy. Teachers, politicians,

ministries of education and other persons participating in this process are invited to rethink education in order to contribute to achieving the goals of sustainable development in the next seven-year period - until 2030.

#### ACKNOWLEDGMENT

This paper is a result of teamwork.

#### REFERENCES

- [1] UN. (2015). *Global sustainable development report*. Available at: <https://sdgs.un.org/sites/default/files/publications/1758GSDR%202015%20Advance%20Unedited%20Version.pdf>.
- [2] UN. (2018). *The 2030 Agenda and the Sustainable Development Goals: An opportunity for Latin America and the Caribbean Santiago*. Available at: [https://repositorio.cepal.org/bitstream/handle/11362/40156/S1801140\\_en.pdf](https://repositorio.cepal.org/bitstream/handle/11362/40156/S1801140_en.pdf).
- [3] UN. (2014). *Global sustainable development report*. Available at: [https://sdgs.un.org/sites/default/files/2022-07/Prototype\\_Global\\_SD\\_Report2014.pdf](https://sdgs.un.org/sites/default/files/2022-07/Prototype_Global_SD_Report2014.pdf).
- [4] Stock, P., & Burton, R. J. F. (2011). Defining terms for integrated (multi-inter-trans-disciplinary) sustainability research. *Sustainability*, 3, 1090 – 1113.
- [5] UN. (2014). *UN system priorities related to science for sustainable development - Background paper on items 4 and 5 of the SAB Terms of Reference (Scientific Advisory Board of the Secretary-General of the United Nations, 2014)*.
- [6] UNESCO. (2017). *Education for Sustainable Development Goals. Learning objectives*. Available at: <https://unesdoc.unesco.org/ark:/48223/pf0000247444>.
- [7] UN. (2022). *The Sustainable Development Goals Report 2022*. Available at: <https://unstats.un.org/sdgs/report/2022/The-Sustainable-Development-Goals-Report-2022.pdf>.
- [8] Wals, A. E. J. (2015). *Beyond unreasonable doubt. Education and learning for socio-ecological sustainability in the Anthropocene*. Available at: [https://arjenwals.files.wordpress.com/2016/02/8412100972\\_rvb\\_inauguratie-wals\\_oratieboekje\\_v02.pdf](https://arjenwals.files.wordpress.com/2016/02/8412100972_rvb_inauguratie-wals_oratieboekje_v02.pdf).
- [9] Wiek, A., Withycombe, L., & Redman, C. L. (2011). Key competencies in sustainability: a reference framework for academic program development. *Sustainability Science*, 6(2), 203–218.
- [10] Mawonde, A., & Togo, M. (2021). Challenges of Involving Students in Campus SDGs-related Practices in an ODeL Context: The Case of the University of South Africa (Unisa). *International Journal of Sustainability in Higher Education*, 22(7), 1487-1502.
- [11] Odelami, B. J., & Fasakin, R. I. (2019). In Pursuit of 2030 Global Agenda; Awareness, Perception and Involvement of Nigerian Youths in Achieving Sustainable Development Goals and the Role of Libraries. *Library Philosophy and Practice*, 1-9.
- [12] Sleurs, W. (2008). *Competencies for ESD (Education for Sustainable Development) teachers. A framework to integrate ESD in the curriculum of teacher training institutes*. Available at: [http://www.unece.org/fileadmin/DAM/env/esd/inf.meeting.docs/EGonInd/8mtg/CSCT%20Handbook\\_Extract.pdf](http://www.unece.org/fileadmin/DAM/env/esd/inf.meeting.docs/EGonInd/8mtg/CSCT%20Handbook_Extract.pdf).
- [13] UNECE. (2012). *Learning for the Future: Competences in Education for Sustainable Development*. Available at: [http://www.unece.org/fileadmin/DAM/env/esd/ESD\\_Publications/Competences\\_Publication.pdf](http://www.unece.org/fileadmin/DAM/env/esd/ESD_Publications/Competences_Publication.pdf).
- [14] UNESCO. (2020). *Education for Sustainable Development – A Roadmap*. Available at: <https://www.gcedclearinghouse.org/sites/default/files/resources/200782eng.pdf>.
- [15] UNESCO. (2022). *Youth demands for quality climate change education*. Available at: <https://unesdoc.unesco.org/ark:/48223/pf0000383615>.
- [16] EUR – Lex. (2019). *Paris Agreement*. Available at: <https://eur-lex.europa.eu/legal-content/EN/TXT/?uri=CELEX%3A22016A1019%2801%29>.
- [17] IPCC. (2018). *Global Warming of 1.5°C. An IPCC Special Report on the impacts of global warming of 1.5°C above pre-industrial levels and related global greenhouse gas emission pathways, in the context of strengthening the global response to the threat of climate change, sustainable development, and efforts to eradicate poverty*. Cambridge University Press.
- [18] McCloskey, S. (2016). Are We Changing the World? Reflections on Development Education, Activism and Social Change. *Policy and Practice. A Development Education Review* 22, 110–130.
- [19] UNESCO. (2014). *Education Strategy 2014-2021*. Available at: <https://unesdoc.unesco.org/ark:/48223/pf0000231288>.

# Naïve Bayes Classifier Model for Predicting Admission in Master's Program Based on Academic Grades

Kavita Gupta<sup>1</sup>

<sup>1</sup>Department of Mathematics, Kirori Mal College, University of Delhi, Delhi, India

<sup>1</sup>gupta\_kavita31@yahoo.com

**Abstract**—In this paper, a machine learning algorithm Naive Bayes Classifier is applied to the admission prediction dataset available on Kaggle. The dataset consists of eight attributes: GRE Score, TOEFL score, University rating, SOP, LOR, CGPA, Research and Chance of admission. The target variable is “chance of admission” which can be predicted according to the input given in terms of other seven attributes. The model developed in this paper will assist the students in predicting whether they have a chance to get admission in post-graduate programs across varsities based on their academic performance. Computing software R is used for performing data analysis and data interpretation.

**Keywords** - Naïve Bayes Classifier, machine learning, predictive analytics, artificial intelligence, supervised machine learning

## I. INTRODUCTION

Now a days, the students prefer to study abroad for many reasons such as excellent career opportunities, enhanced language skills, exposure to new culture and educational system, overall personality development and many others. But the biggest problem is that they face difficulty in choosing a proper institution for pursuing masters based on their academic performance. Parents face huge problem in arranging funds for their wards' admission in overseas universities. One needs funds even to apply in Universities of National and International repute. A student is unaware of the places where they might be admitted based on their performance. A student can avoid wasting money by applying to universities that are out of his financial grasp if he can predict in advance

where he would be admitted based on his GRE, TOEFL, research, CGPA, etc. scores. This fact motivated the author to study the students' grades and the likelihood of admission to programs so that a student can forecast the probability of being accepted in the master's program in any university across the globe and can manage the necessary funding accordingly. This study's objective is to evaluate a student's academic performance and university ranking in order to determine the likelihood that student will be admitted to that particular university.

The fields of data mining and machine learning have evolved and attracted attention in recent years to analyze acquired data. Data mining is the best process of extracting data from a dataset and using that data to find relevant information. The evaluated data is then used to improve the decision-making process. It employs several algorithms in an effort to identify particular patterns in the data. Moubayed et al. [1] focused on the importance of machine learning and data analytics to extract information and finding valuable patterns within the collected data. This ultimately helps in prediction based on historical data. Essalmi et al. [2] provided generalized criteria that assist teachers in evaluating and contrasting personalization tactics and selecting the best one to use for each course. Experiments were used to test the approach's viability and effectiveness when used with a wide range of learning items and learner characteristics. Wan and Niu [3] put emphasis on e-learning recommender systems. Kaur and Singh [4] predicted the class performance using the WEKA tool, Naïve Bayes and J48 decision tree classification approaches. Injadat et al. [5]

analyzed two different undergraduate datasets at two different universities to predict the students' performance at two stages of course delivery. Acharya et al. [6] predicted the chances of admission in different universities by comparing the results obtained on applying different machine learning algorithms such as Random Forest, regression, support vector machine, decision trees etc. Lykourantzou et al. [7] predicted dropout rate in e-learning courses through the combination of machine learning techniques. Many researchers such as Luan [8], Herbert [9] and Vandamme et al. [10] focussed on the importance of data mining and its applications in higher education. Batta [11] has recently provided a review on machine learning algorithms. Machine learning models are now a days recently used by many researchers in the field of medicine. For instance, Kar et al. [12] presented a model on mortality risk prediction into COVID clinical and laboratory parameters at admission in hospitals. Gao, Y., Cai, GY., Fang, W. et al. [13] resented a model that enables expeditious and accurate mortality risk stratification of patients with COVID-19, and potentially facilitates more responsive health systems that are conducive to high risk COVID-19 patients. Brajer N, Cozzi B, Gao M, et al. [14] created a machine learning model that predicts in-hospital mortality for all adult patients at the time of hospital admission and prospectively and externally validate it using data from widely accessible electronic health records and easily accessible computational techniques.

In this paper, we have used the machine learning algorithm "Naïve Bayes algorithm" to predict chances of admission in masters' program based on students' academic score. The Naive Bayes algorithm is a supervised learning technique that applies the Bayes theorem to tackle classification issues. With a sizable training dataset, text classification is its main use. It is an easy-to-use and effective classification technique that helps create quick machine learning models that are capable of providing prompt predictions. Being a probabilistic classifier, it makes predictions based on the likelihood that an object will occur. The Naive Bayes classifier is supported by the Bayes theorem. Due to its ease of use and linear runtime, the Naive Bayes classifier is still a common learning method for data mining applications. The categorical parameters are assumed to be statistically independent given the class in this method. As a result, the approach is

straightforward and has linear training times for both the number of examples and the characteristics.

## II. DATA COLLECTION AND DESCRIPTION

### A. Data Description

The data set imported from Kaggle consists of 400 rows and 9 columns. The various attributes presented in nine columns are Serial number, GRE score, TOEFL score, University rating, SOP, LOR, CGPA, Research, Chance of admission. The description of all the independent and dependent variables are given below:

1. **GRE Score:** It is Graduate Record Exam score. The score will be out of 340 points. This exam is required for admission to graduate programs globally.
2. **TOEFL:** It is Test of English as a Foreign Language which will be out of 120 points. It is a standardised test used to assess the English language proficiency of non-native speakers looking to enrol in universities that use the English language.
3. **University Rating:** It indicates the ranking of the university from where the student has graduated among the other universities. The score will be out of 5.
4. **Statement of purpose (SOP):** It is a document written by the student addressing the admission committee. It includes career path, ambitions interests, professional and academic accomplishments, and the inspiration for choosing a specific programme. The score will be out of 5 points.
5. **LOR** is the Letter of Recommendation which verifies the candidate professional experience, builds credibility, boosts confidence and ensures competency. The score is out of 5 points.
6. **CGPA:** It is the cumulative grade point average which is actually the academic score of the student at under-graduate level. This score is out of 10.
7. **Research:** It includes the research experience of the student such as publishing research papers in various journals of National and international

repute. Further, it includes working as a research assistant with a university professor. It is a factor variable that takes two values 0 or 1.

8. Chances of admission: It is the only dependent variable which can be predicted based on the students' score in the other seven attributes discussed above.

The admission data is collected from Kaggle. Structure and first six rows of the dataset are extracted using R software. Table I shows the first six rows of the dataset.

TABLE I. ADMISSION PREDICTION DATA

GRE	TOEFL	Uni.Rating	SOP	LOR	CGPA	Research	Chances of admission
337	118	4	4.5	4.5	9.65	1	0.92
324	107	4	4.0	4.5	8.87	1	0.76
316	104	3	3.0	3.5	8.00	1	0.72
322	110	3	3.5	2.5	8.67	1	0.80
314	103	2	2.0	3.0	8.21	0	0.65
330	115	5	4.5	3.0	9.34	1	0.90

### III. SOLUTION METHODOLOGY

The stepwise procedure to apply the Naïve Bayes Classifier to the input data is explained in the following steps.

#### A. Step 1: Pre-processing of the Dataset

The dataset is first examined for the presence of any null values. If any text is null, it is converted to empty string. In Naïve Bayes classification, the target variable should be categorical. So, the next step is to convert the output variable "chance of admission" in to factor type. Chances of admission ( $x$ ) will have four factors as shown in Table II.

TABLE II. CHANCES OF ADMISSION

Value of $x$ (Chances of admission)	Factor
$0 \leq x \leq 0.3$	No chance
$0.3 < x \leq 0.5$	low
$0.5 < x \leq 0.8$	medium
$x > 0.8$	High

#### B. Step 2: Data Visualization

It includes the determination of correlation matrix between all the numerical variables which is shown in Table III. In order to visualize the correlation matrix, we may draw a heat map as shown in Fig. 1. This heat map shows that the chances of admission are highly related to CGPA, GRE, TOEFL scores.

TABLE III. CORRELATION MATRIX

	GRE	TOEFL	Uni.Rating	SOP	LOR	CGPA	Research	Chances of admission
GRE	1.0000000	0.8359768	0.6689759	0.6128307	0.5575545	0.8330605	0.5803906	0.8026105
TOEFL	0.8359768	1.0000000	0.6955898	0.6579805	0.5677209	0.8284174	0.4898579	0.7915940
Uni.Rating	0.6689759	0.6955898	1.0000000	0.7345228	0.6601235	0.7464787	0.4477825	0.7112503
SOP	0.6128307	0.6579805	0.7345228	1.0000000	0.7295925	0.7181440	0.4440288	0.6757319
LOR	0.5575545	0.5677209	0.6601235	0.7295925	1.0000000	0.6702113	0.3968593	0.6698888
CGPA	0.8330605	0.8284174	0.7464787	0.7181440	0.6702113	1.0000000	0.5216542	0.8732891
Research	0.5803906	0.4898579	0.4477825	0.4440288	0.3968593	0.5216542	1.0000000	0.5532021
Chances of admission	0.8026105	0.7915940	0.7112503	0.6757319	0.6698888	0.8732891	0.5532021	1.0000000

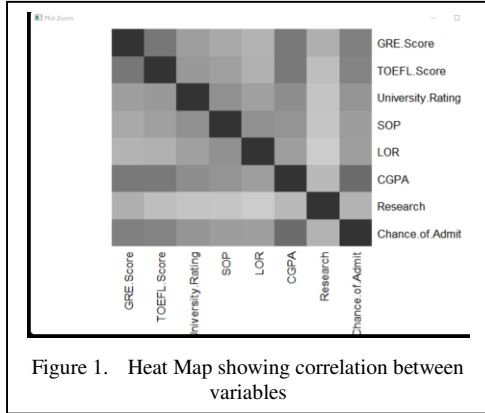

Figure 1. Heat Map showing correlation between variables

### C. Step 3: Summary of Admission Data

Chances of admission are categorized as high, low and medium. Proportion of chances of admission in these three categories are shown in Table IV. The summary of admission data includes minimum, maximum, lower quartile, upper quartile, mean values of each of the eight attributes. This summary is shown in Table V.

TABLE IV. CHANCES OF ADMISSION

Factor	High	Low	Medium
Frequency	117	35	248
Proportion	0.2925	0.0875	0.6200

TABLE V. SUMMARY OF ADMISSION DATA

	GRE	TOEFL	Uni.Rating	SOP	LOR	CGPA	Research	Chance of admission
Minimum	290.0	92.0	1.000	1.0	1.000	6.800	0.0000	0.3400
Lower quartile	308.0	103.0	2.000	2.5	3.000	8.170	0.0000	0.6400
Median	317.0	107.0	3.000	3.5	3.500	8.610	1.0000	0.7300
Mean	316.8	107.4	3.087	3.4	3.453	8.599	0.5475	0.7244
Upper Quartile	325.0	112.0	4.000	4.0	4.000	9.062	1.0000	0.8300
Maximum	340.0	120.0	5.000	5.0	5.000	9.920	1.0000	0.9700

### D. Step 4: Fitting Naïve Bayes to the Training Dataset and Prediction

Split the dataset in to two parts according to thumb rule: 75% training data and 25% testing data. Then we create training label and testing labels. Labels are “chances of admission” attribute i.e., the target variable in the original data. Install package e1071 for Naive Bayes classifier. Use the predict() function of NB classifier for prediction. Code for prediction using NB classifier is given in Table VI.

TABLE VI. PREDICTION USING NB CLASSIFIER

R-Code For Prediction Using NB Classifier
install.packages("e1071")
library(e1071)
classifier<-naiveBayes(train_data,train_label)
classifier_predict<-predict(classifier,test_data)

matrix to find misclassification in prediction. Code for generating cross tables and confusion matrix are given in Table VII.

TABLE VII. CODE FOR CROSS TABLES AND CONFUSION MATRIX

R Code for Creation of Cross Tables and Confusion Matrix
install.packages("gmodels")
library(gmodels)
CrossTable(test_label,classifier_predict,prop.r=T,prop.c=F,prop.t=F,prop.chisq=F,dnn=c("Actual","predicted"))
confusionmatrix<-table(test_label,classifier_predict)
confusionmatrix
conf_prop<-
prop.table(table(test_label,classifier_predict))
conf_prop
1-sum(diag(conf_prop))/sum(conf_prop)

### E. Step 5: Creation of Cross Tables and Confusion Matrix

We prepare cross table by using CrossTable() function of gmodels package to find the accuracy in the prediction. Create confusion

## IV. DATA ANALYSIS AND INTERPRETATION

After predicting the output using Naïve Bayes classifier, the following results are obtained. Cross table (Table VIII) and confusion matrix (Table IX) with Laplace Value = 0 shows

that out of total 305 observations, 205 observations are predicted correctly whereas 100 observations are misclassified. One can interpret that chances of admission is high in 30 cases actually which are predicted correctly 12 number of times but are wrongly predicted as low 5 times and medium 13 times. The values on the diagonal of cross tables shows correct classification whereas the other entries show misclassification. The percentage of correct prediction is 67.21%. One can improve the performance of the model by changing the Laplace value from 0 to 1,2,3 and so on.

TABLE VIII. CROSS TABLE

Actual↓ Predicted→	High	Low	Medium	Row total
High	12 0.4	5 0.167	13 0.433	30 0.098
Low	2 0.017	74 0.638	40 0.345	116 0.380
Medium	9 0.057	31 0.195	119 0.748	159 0.521
Column total	23	110	172	305

TABLE IX. CONFUSION MATRIX

predict→ test_label↓	High	Low	Medium
High	12 0.039	5 0.016	13 0.043
Low	2 0.0065	74 0.2426	40 0.1311
Medium	9 0.0295	31 0.1016	119 0.3902

## V. CONCLUSION

In this paper, a machine learning algorithm namely, Naïve Bayes Classifier is used with a default Laplace value = 0 to predict the chances of admission in master’s program overseas on the basis of academic grades. The academic grades include GRE score, TOEFL score, University rating, SOP, LOR, CGPA, Research. The target variable “Chances of admission” depends on these seven attributes. By means of cross tables and confusion matrix, it is observed that the misclassification in chances of admission is 33.44%. One can improve the performance of the model by increasing the Laplace value. As future work is intended, one can study the same dataset by applying other machine learning algorithms such as Random Forest, Decision Trees, Linear Regression, Logistic Regression, KNN algorithm, cluster analysis , support vector machines etc.

## ACKNOWLEDGMENT

The author is thankful to the reviewers for their valuable comments and suggestions.

## REFERENCES

- [1] Moubayed, A., Injadat, M., Nassif, A. B., Lutfiyya, H., & Shami, A. (2018). E-learning: Challenges and research opportunities using machine learning & data analytics. *IEEE Access*, 6, 39117-39138.
- [2] Essalmi, F., Ayed, L. J. B., Jemni, M., Graf, S. (2015) Generalized metrics for the analysis of e-learning personalization strategies. *Computers in Human Behaviour*, 48, 310–322.
- [3] Wan, S., & Niu, Z. (2018). An e-learning recommendation approach based on the self-organization of learning resource. *Knowledge-Based Systems*, 160, 71-87.
- [4] Kaur, G., & Singh, W. (2016). Prediction of student performance using weka tool. *An International Journal of Engineering Sciences*, 17, 8-16.
- [5] Injadat, M., Moubayed, A., Nassif, A. B., & Shami, A. (2020). Multi-split optimized bagging ensemble model selection for multi-class educational data mining. *Applied Intelligence*, 50, 4506-4528.
- [6] Acharya, M. S., Armaan, A., & Antony, A. S. (2019, February). A comparison of regression models for prediction of graduate admissions. In *2019 international conference on computational intelligence in data science (ICCIDIS)* (pp. 1-5). IEEE.
- [7] Luan, J. (2002). Data mining and its applications in higher education. *New Directions for Institutional Research* 2002, 113, 17–36.
- [8] Herbert, M. (2006). Staying the course: A study in online student satisfaction and retention. *Online Journal of Distance Learning Administration*, 9(4), 300-317.
- [9] Lykourantzou, I., Giannoukos, I., Nikolopoulos, V., Mpardis, G., & Loumos, V. (2009). Dropout prediction in e-learning courses through the combination of machine learning techniques. *Computers & Education*, 53(3), 950-965.
- [10] Vandamme, J. P., Meskens, N., & Superby, J. F. (2007). Predicting academic performance by data mining methods. *Education Economics*, 15(4), 405–419.
- [11] Mahesh, B. (2020). Machine learning algorithms-a review. *International Journal of Science and Research (IJSR).[Internet]*, 9, 381-386.
- [12] Kar, S., Chawla, R., Haranath, S. P., Ramasubban, S., Ramakrishnan, N., Vaishya, R., ... & Reddy, S. (2021). Multivariable mortality risk prediction using machine learning for COVID-19 patients at admission (AICOVID). *Scientific reports*, 11(1), 1-11.
- [13] Gao, Y., Cai, G. Y., Fang, W., Li, H. Y., Wang, S. Y., Chen, L., ... & Gao, Q. L. (2020). Machine learning based early warning system enables accurate mortality risk prediction for COVID-19. *Nature communications*, 11(1), 5033.
- [14] Brajer N, Cozzi B, Gao M, et al. (2020). Prospective and External Evaluation of a Machine Learning Model to Predict In-Hospital Mortality of Adults at Time of Admission. *JAMA Network Open*, 3(2):e1920733.





# Knowledge Management Strategy, Resources and Competences

Milovan Rogan<sup>1</sup>

<sup>1</sup>University of Niš, Faculty of Economics, Niš, Serbia

<sup>1</sup>milovanrogan@gmail.com

**Abstract**—Knowledge management is an increasingly topical subject in the field of management. Knowledge represents a company's resource on which the company's competitive advantages are increasingly based. This paper will deal with the problem of identifying knowledge as a resource that exists in all organizational parts. Knowledge management implies the application of knowledge on a larger scale and in a better way, so in this work special importance is given to the problem of knowledge application from the aspect of disposing of existing knowledge, but also methods for improving knowledge. The mobility of knowledge makes managing it difficult, but it also gives the company the character of flexibility, which is the basis for maintaining competitiveness in modern conditions.

**Keywords** - knowledge management, competitiveness, resources, learning

## I. INTRODUCTION

Companies, as the main business entity, have various resources at their disposal in order to perform their activities. The structure of resources is different in all companies and it changes with the passage of time on a global level. In the past, natural resources were a necessary resource for the functioning of companies, that is, they were a source of competitive advantage. Throughout history, it was manpower, capital, means of work, and today it is knowledge. In modern business conditions, where information technology and other types of modern achievements are very prevalent, knowledge is a key resource for the functioning of the company. It is precisely on this resource that the highest level of competitive advantage and value creation for consumers as end users and verifiers of value creation is based. Due to its importance and complexity of

disposal, knowledge management is a significant management process that must be applied in almost all larger companies.

## II. KNOWLEDGE AS A COMPANY RESOURCE

In order to function and survive on the market, the company as a basic economic entity must have various knowledge and skills, starting from organizational through specialized technical and technological knowledge related directly to the company's activities, and up to knowledge that is applied in the field of marketing and sales. No company, no matter how similar they are or perform a similar activity, has even close to the same skills and competences. It is one of the main reasons that appear in the competitiveness of companies, but also in the way of functioning or organization of each company separately.

The knowledge resource in a company is manifested through the knowledge and skills of the employees, from the production workers themselves to the management level, then through the organizational hierarchy that defines the way of management and communication channels, work procedures, technical documentation on the basis of which a certain product is made (this can be a recipe in the food, pharmaceutical or chemical industry), technological documentation that describes in detail the way in which production is carried out, the procedures that are applied in the product quality control process.

Above all, the knowledge that is closely related to the production segment must certainly be included in the knowledge possessed by workers who work in the sectors of procurement, logistics, sales, marketing, after-sales services, etc. Procedures, ways of working as well as the

results of previous analyzes represent a great source of knowledge in the mentioned areas. A large database in every company is also an accounting system that identifies and systematically records all changes that take place in the company. Based on the accounting data, various reports are created which in the future can serve as a basis for improving business processes and carrying out activities in a better way.

Based on the above, we can conclude that the main subjects of knowledge in the company are:

1. Human resources, professional skills of employees at all levels;
2. Experiential data that the company has at its disposal from the production segment, through logistics, finance to sales, including all types of databases in the framework of information systems;
3. Work procedures and instructions defining the implementation of each activity that takes place in the company (including written documents, audio and video recordings);
4. The organizational structure of the company and the organizational capabilities arising from it.

As we can see, the knowledge resource is widely distributed in the company, the more of this resource within the company, the competitive ability of the company increases, but the complexity of managing this resource also increases. If these resources are not sufficiently identified or if they are used inefficiently, the company will miss numerous opportunities, bearing in mind the intense competition that will realize all its advantages in the areas of its dominant knowledge, missing opportunities will consequently lead to a weakening of competitiveness and endangering the functionality of the company. Knowledge is an intangible resource that is more difficult to identify and more difficult to measure its importance and contribution in financial terms, but no doubt the irrational use of this resource will produce the same negative effects as the irrational use of any other material resource. The same applies to the positive component of the functioning of the enterprise, if it is used correctly and efficiently, it is possible to make serious strides in business [1].

### III. KNOWLEDGE MANAGEMENT PROCESS

The process of knowledge management within the company is a complex and dynamic process that is relatively new in the management system. In order to manage something, one must first identify the subjects of management and determine the importance of each of them [2]. As already mentioned, the carriers of knowledge in the company are people, documents, information data that the company has, as well as the organizational system. In fact, these are all subjects of knowledge that can be used for the purpose of business improvement, the use of knowledge can only be carried out by people, that is, employees of the company.

The identification of knowledge in the company can mostly be carried out by managers from the lowest to the highest levels. Especially when it refers to the identification of knowledge that exists within human resources, a great contribution to the identification of knowledge can also be made by persons who are in charge of forming databases and archiving data, especially if they are included in the processing of relevant data appearing in the company. An accounting system that is modern today with information technology is also a respectable source of information and knowledge that can be used at a given moment. Significant improvement and constant development of information technologies enable the establishment of online programs that can serve to test employees in terms of knowledge of the job for which they are trained, collecting and checking information about the knowledge they have and which they have not previously demonstrated in the jobs they perform. All of these are procedures that contribute to the complete identification of knowledge within the company, which, along with further systematic structuring, is the basis for effective knowledge management.

Considering that the level of knowledge possessed by the company is generally considered very high and that it increases over time, and that the importance of certain knowledge changes over time, as well as the fact that some knowledge becomes obsolete or cannot make a significant contribution to the functioning of the company, it is increasingly being observed the need for centralized coordination of knowledge management. The knowledge management process itself, as well as the management of other resources, is carried out

by management structures at all levels, but due to its specificities and one could say insufficient visibility of this resource, there is a need to define roles such as the knowledge management manager or even in larger companies the management department knowledge. The knowledge management manager should work on the identification of knowledge, determining the level of quality of that knowledge among all employees and at all levels, to contribute to the organization of education that would contribute to the increase of knowledge among employees on a continuous basis without jeopardizing their ongoing operation [3]. It should also provide relevant data to management structures on the basis of which they can make correct decisions about the application of knowledge in certain areas, focusing on certain segments or turning the business strategy, etc.

The process of knowledge management also includes constant learning, i.e. education of employees, in order for the company to maintain its competitive position, bearing in mind that other companies also apply new knowledge and make improvements in this area. The quality of education and the intensity with which it is carried out depends on whether the company will remain in the same position in relation to its competitors or will improve its position. Of course, there is no direct correlation between these processes, because other business factors, i.e. other resources available to companies, also play a role in market positioning.

The improvement of knowledge is carried out through the improvement of information bases, by simplifying their access, by improving communication between employees, by establishing greater interaction between organizational segments. The improvement of knowledge is also carried out through connecting and better familiarizing employees with the vertical and horizontal structure of the company's organization. Also, the establishment of universal principles that represent the doctrine of corporate functioning in the essential sense contribute to a better application and improvement of knowledge among employees.

In addition to identifying knowledge and improving knowledge within the company, a very important part of knowledge management is the adequate application of knowledge that is, maximizing knowledge in business areas in which the company stands out compared to its competitors. If management analyzes show that

it has specific knowledge in production that other companies do not have to a sufficient extent, certainly the focus of improving the application of knowledge should be in that organizational part. This implies the improvement of existing products, the introduction of new ones or even the expansion of activities to areas where the available knowledge can be applied so that it will create a dominant position in that new market segment. Creating a competitive advantage based on knowledge is a very suitable process that creates a marked increase in the profitability and competitiveness of the company.

The focus on a specific area prompted by expressed competence must be timely and dynamically coordinated with the availability of other resources, this makes the process of management and focusing even more complex, which is why the entire process must be led by the highest levels of the management structure. It is very important to point out that creating a competitive advantage based on knowledge can be achieved in all segments of the company, but also the process of identifying advantages in a specific area and reacting to that possibility can take time, which in a highly dynamic business environment represents a significant risk of changing the position and the existence of a competitive advantage in general. When analyzing knowledge and application potential, attention must be paid to the nature of the competitive advantage arising from this type of resource. It should be evaluated whether the advantage is short-term or permanent, and how certain it is to maintain that advantage in a certain period.

The advantage in knowledge that the company has is most obviously manifested through the application of innovations, which can be in the area of product construction and quality, within the means of production or in other business segments that are also important for the functioning of the company. Therefore, we can apply knowledge through innovations or by increasing the intensity of application within the existing business processes, which will therefore become better quality and more efficient. Another type of manifestation of knowledge in the company is the increase in productivity, i.e. speeding up production processes with the same number of workers and the same means of work. We often say that more experienced workers perform certain processes better and faster, and this essentially means that workers who have been performing the same or

similar jobs for many years acquire additional practical knowledge in a certain area, as a result of which they perform business processes significantly more efficiently.

The most important source but also the bearer of the application of knowledge are employees, it depends on them how effectively the available knowledge will be used. Given that most workers have the freedom to leave the company at any time without special compensation or restrictions, the risk of knowledge fluctuation is very pronounced. In this context, the strategy of knowledge management and how it must be connected with the strategy of human resources management, in terms of education, training, increasing the safety of employees, and all with the aim of increasing the loyalty of employees to the company [4]. In this way, a stable level of knowledge can be ensured in the company, which can later be a real economic potential. Another problem that is also expressed in this segment is the security of knowledge.

Knowledge as an intangible resource is not easy to secure, starting from information systems that are a kind of base or archive of available knowledge, they are often the target of illegal download of data, whether it is through unauthorized use and distribution of data by employees or intrusion into the system of third parties. Also, it very often happens that employees transfer their knowledge with financial compensation to other companies that represent competition, even if they should not do so according to the employment contracts, but due to the difficulty of controlling the flow of knowledge and proving its origin, the mentioned process is very present and represents a significant danger to the functioning of the company and especially to the competitive advantage based on this resource.

A large number of companies have employees with a pronounced character of loyalty and a sense of belonging to the company. Such companies can and should push for the creation of a competitive advantage based on knowledge in all business segments, starting with the procurement process and ending with the sales process. Those companies can carry out their accelerated development without excessive investments, but it is necessary that the personnel potential, which is the greatest source of knowledge, be developed with quality and filled with new adequate personnel.

#### IV. KNOWLEDGE AS A SOURCE OF FLEXIBILITY

Modern companies are faced with very strong competition, which is threatened by direct competitors, but due to the accelerated process of application of innovations, competition often appears from an unexpected side through the entry of new business players into a certain market branch, or through the appearance of substitutes for existing products from other branches [5]. An increasing number of companies appear on a global level, so it is not even possible to completely determine who the main and direct competitors are. The dynamic business environment imposes the need for constant and accelerated adjustments to market conditions. The adjustment process is not at all easy and can very often be extremely expensive, and the effects extremely uncertain.

Companies that have a significant level of knowledge are able to adapt to market conditions much faster and easier. This is shown by numerous researches, it is interesting that the results are similar in less and more developed economies. Companies that have built up this resource, especially those that have a well-organized management of it, are able to adapt their product range much faster to the needs of the market and not spend too much money. They are also able to conquer the production of new products that are sold in some other market segments, relatively quickly and without excessive additional investments. It has already been mentioned that the complicating factor of knowledge management is its mobility, which is expressed through the easy transferability of documented knowledge through information systems, and the mobility of the workers themselves who are the primary carriers of knowledge, and who can easily and quickly change their work location.

In terms of increasing flexibility and adaptability, the deficiency just described is an advantage, which the company must carefully guard so that this feature of knowledge remains an advantage and not a disadvantage for the company. Companies with a high level of knowledge as a resource, which is well managed in conditions of pronounced globalization, represent the safest and most resilient economic subjects. This is not the case for joint ventures that have large material resources, their flexibility is expressed in the form of changing the purpose of the wine, but exclusively at the same location with significant additional

investments. Changing the location when the production equipment is in question is possible, but with extremely high costs of disassembly, transport and re-installation. All of this makes companies with valuable material resources inflexible and vulnerable to market fluctuations.

Companies with highly developed knowledge-based management skills build special business functions that should contribute to the security of the company's functioning over a longer period of time. In accordance with that, risk assessment services, knowledge management services, asset management services, human resources etc. are formed. All these creations are based on knowledge that is generally available in the environment, but also on specific knowledge that the company has. All these resource management procedures should increase the flexibility of the company due to market conditions that are uncertain and largely unpredictable.

## V. CONCLUSION

Knowledge as a company resource has always been present and necessary for the functioning of the company. With the development of the market on a global level, it is realized that knowledge is an increasingly important and valuable resource that increasingly becomes the basic source of competitive advantage. In order to use its values and eliminate the weaknesses it can produce in the functioning of the company, a systematic system of knowledge management was established. The process of knowledge management manifests itself in three basic forms, namely: identifying knowledge, improving knowledge, and applying knowledge within existing or new business processes in the company.

Organizational hierarchy, communication channels, databases, knowledge improvement procedures, and employees themselves represent constructive elements of knowledge as a resource in a company. Each of these elements should be analyzed and improved through the process of knowledge management. The availability of knowledge is not enough by itself, as with other resources, it is only through its application that new value begins to be created, which is

imperative for the functioning of the company. Effective knowledge management implies that certain competencies that are the company's advantage are applied in the same way in other segments of the company, that new activities are formed on their basis or the company's activities are expanded. A very important feature of knowledge that companies should use is its flexibility. If the highest management structure in the company correctly values and respects this feature, it is possible to significantly increase the flexibility of the company and make it safer and more resistant to the dangers that come from the market environment, which is today of a global character. Due to its characteristics, knowledge in today's conditions represents the primary source of competitive advantage and security of companies.

Knowledge management is already one of the key business processes, the intensity of knowledge application will only increase, and therefore the importance of managing this resource will continue to increase. Better and easier identification of knowledge as a resource within the company should contribute to its greater marketability through the improvement of existing products or through the introduction of new ones, but through the transfer of knowledge itself as a resource that will be adequately financially valued. Further research should be focused on the evaluation of knowledge and its balancing as a real economic quantity that exists in the company and that represents the basis for creating a competitive advantage.

## REFERENCES

- [1] Slavković, M. (2020). *Upravljanje znanjem – Strategijski i organizacioni aspekti*. Ekonomski fakultet Kragujevac CID, 66-72.
- [2] Siegfried, J. J., Sanderson, A. R., & McHenry, P. (2007). The economic impact of colleges and universities. *Economics of Education Review*, 26(5), 546-558.
- [3] Ćirić, I., Ćirić, Z., Eremić-Đodić, J., Perin, J., (2014). *Upravljanje znanjem u ostvarivanju konkurentske prednosti preduzeća, Info-teh*, Jahorina.
- [4] Santosus, M., Surmacz, J. (2001). *The ABCs of Knowledge Management*. *CIO Magazine*.
- [5] Nicolas, R. (2004). Knowledge management impacts on decision making process. *Journal of Knowledge Management*, 8(1).



# Funding Models in the European Startup Ecosystem

Aleksandar Vekić<sup>1</sup>, Jelena Borocki<sup>2</sup>, Ana Ivanić<sup>3</sup>, Galina Žižakov<sup>4</sup>

<sup>1,2,3,4</sup>University of Novi Sad, Faculty of Technical Sciences, Novi Sad, Serbia

<sup>1</sup>vekic@uns.ac.rs, <sup>2</sup>borocki@uns.ac.rs, <sup>3</sup>ana.ivanic97@gmail.com, <sup>4</sup>galina.zizakov@gmail.com

**Abstract**—The basic drivers and the “connective tissue” of startup ecosystems are connections and interactions that take place between members of these ecosystems and contribute to their progress and innovation. In addition to subjects and their mutual interactions, it is important to note that resources like knowledge, experience, skills and money are vital components for survival, growth and development of startup ecosystems. Resources that flow through ecosystems are provided primarily from people and organizations that are an active part of these startup ecosystems. The focus of the research is aimed at the process and sources of funding within the European startup ecosystem. Cash assets as a resource have a crucial role in achieving the potential and setting the goals of newly established business ventures. By providing support and investing in Startup companies, multiple benefits are achieved. The success of a specific endeavor has an impact on the entire regional startup ecosystem within which the specific endeavor is located. The power of ecosystem is reflected in the stability and success of all its members. The aim of this research is to compare startup ecosystems of selected European Union countries for the period from 2019-2022, including Serbia which is currently in amidst entrance negotiations. The comparison was performed according to the selected indicators of selected startup ecosystems, which are as follows: the total value of the startup ecosystem and investment in the initial stages of the company startup.

**Keywords** - startup ecosystem, Europe, funding models, growth encouragement

## I. INTRODUCTION

The question of ventures funding within the startup ecosystem should be approached methodically and thoroughly, in order to create baselines for the sustainability and development

of these ecosystems. The main task of all countries is to encourage entrepreneurship and innovation and to provide conditions for the accelerated growth of their economies, allow for talent acquisition and their employment. It also allows the creation of innovative products/services or processes, which greatly contributes to the competitiveness of the economy. The startup companies are mainly managed by their founders who are fighting for the success of their business ventures.

Wennekers & Thurik agreed that entrepreneurship affects the economy directly and indirectly, at different levels, through innovation, competition and restructuring [1]. Empirical research has shown that a higher opening rate of new companies and higher turbulence rate (the sum of opening and closing) encourage economic growth and job creation [2]. Entrepreneurship is a way of thinking, i.e. the process of creating and developing economic activities by combining risks, creativity, and/or innovation with a reliable management structure within the new or existing organization [3]. Building on previous definitions, it can be noticed that entrepreneurship as a sort of human activity has a great importance for the economic and social development of the community, which is why the efforts of social communities are designed by measures and activities to encourage entrepreneurial activity in their territories.

The term “entrepreneur” was first defined by Jan Baptiste Say in 1803, and “the entrepreneur shifts economic resources from the field of lower to the field of higher productivity and larger yield” [4]. Over the years, three authors were the key to adopting the notion “Entrepreneur” and “Entrepreneurship”, Joseph Schumpeter, Frank Knight and Israel Kirzner. Schumpeter suggested



that entrepreneurs - not only companies - are responsible for innovating in the search for profit. Knight focused on entrepreneurs as carriers of uncertainty and believed that they were responsible for risk premiums in financial markets. Kirzner believed that entrepreneurship was a process that leads to the discovery [5].

Innovation is of great importance for business, and thus society as a whole, therefore it is of great interest for economic entities and governments. According to Peter Drucker "Innovation represents a new product/service, the process or improvement of technology, which are incurred by applying their own or otherwise scientific research, learning and development, which is placed on the market" [6]. Innovation is primarily related to creating more efficient and faster processes, products and ideas. If business is coming from the point of view, it means the implementation of new ideas, improving services or creating dynamic products. It can act as a catalyst that will improve the task and help each individual adjust to the market. Innovation can lead to a change in the business model. Successful innovation should be part of the business strategy of each entrepreneur. It can also increase the probability that the company creates more efficient processes, which will result in better productivity and performance. In general, the main purpose of innovation through entrepreneurship is reflected in improving people's lives. When it comes to company management, innovation is the key to progress [7].

Based on innovation, new business ventures are created, and they are called startups. Eric Ries defines a startup as "an institution made of people, designed to deliver a new product or service in conditions where there is a high factor of uncertainty" [8]. The startup is a business venture that is not over 10 years of age or older, based on new sale model and whose realization has enabled the development of innovative technology [9]. The startup can be defined as: "a temporary organization that is looking for a sustainable and scalable business model" [10].

Startup ecosystem can be seen as the environment developing the startups, which are made up of individuals, teams, different types of organizations and institutions acting as a system with the aim of creating and accelerating the development of new startups [11]. The goal of the ecosystem is to starting and developing companies. The common resource fund usually

includes: policy makers, accelerators, incubators, co-working spaces, educational institutions and funding groups.

The startup ecosystem is affected by three key factors [12]:

- critical mass of entrepreneurs, companies and specialized institutions at a specific location,
- developed network of attitudes between actors, and
- cultural basis that connects all the elements.

In order for the startup company to open its doors and have them permanently opened it needs capital until it reaches the business phase in which it is profitable. The money, in addition to allowing the life and growth of the company, most often represents a competitive advantage when it comes to hiring staff, publicity, marketing and sales relationships. The amount of money needed to make the startup lead to profitability levels, most often exceeds the possibilities of founders, their families and friends. Although banks act as the next logical option to turn, there are other sources of funding that can be considered.

Investors are constantly searching for better opportunities to invest their own resources in and potentially increases them.

In order to provide the necessary capital, the founders must be connected to investors, determine where the money is located and who owns it.

## II. RESEARCH METHODOLOGY

The methodology used when implementing this research includes the analysis of secondary data in four consecutive years 2019 - 2022. The discussion was formed on the analysis of data on startup ecosystems and financing values in the initial stages of the company. What matters is the fact that during the years, the Startup Genome organization changed the methodology of making reports, which resulted in changes in data presentation when making this study. Within this paper, the results obtained by the research and analysis of the Startup Ecosystems in the countries of the European Union, and the Republic of Serbia, as the countries of the candidate for membership, whose data is complete in reports in the observed period. This research therefore covering the following

countries: Denmark, Finland, France, Hungary, Germany, Ireland, The Netherlands, Sweden and Serbia. As the reports of the reasons for improving the methodology through the years have been a constant effort of organization in the direction of improving the methods of measuring startups and ecosystems that belong to, with the achievement of objectivity and precision [13].

### III. TYPES OF FUNDING SOURCE FOR STARTUPS

As the most common sources of funding for startup companies appear:

*Self-financing* is one of the most common ways to ensure the necessary funds to start a startup company, especially in the earlier stages of its development. Although there are new companies that are funded by risk capital and bank loans, most entrepreneurs and their startups, which do not really require large investment, rely on friends, family and own savings [14]. Judging by the statistics, between 35 - 40% startup ventures were funded by the family, acquaintance or friend of the founder [15]. In addition to FFF investor, a good source of funding for startups can also be users, better known under the term “early adopters”. They provide evidence of sustainability of the concept of business venture to future investors, but also funds that are currently needed. Incentives are commonly given for the early adopter purchase of products or services before their official placement on the market. Big discounts are mainly offered, additional services, free subscription, networking awards to new customers and many others.

*Commercial loans (lending)* - The next option offered to the founders as a source of security for the necessary capital are commercial institutions that offer money at a certain price, and it is banks. About 40% of the startup capital comes from loans that offered by banks [16]. The loan represents the debtor - the credit relationship in which the bank as the creditor provides the right to dispose of his client - the debtor, for a certain period of time and under certain conditions.

Grants - A grant is a direct financial participation, which is given in the form of a donation, for financing [17]:

- activities aimed at achieving a goal that is a part of the European Union policy; or,

- work of a body of labor that strives to achieve the goal of general European interest or whose goal forms part of the European Union's strategic commitment.

Grants or donations are a kind of funding sources assigned by an entity, usually a company, foundation, government, international organization to an individual or company to facilitate the achievement of the predicted goal or encourage the effect. The grants represent a perspective source of funding, both in the initial phases of launching business venture, and in later stages. The largest project financing program, i.e. the public grant program in Europe is the Horizon Europe Program. The Horizon Europe is a key EU program for financing research and innovation with a budget of 95.5 billion [18].

*Incubators and accelerators* - For startups in the initial phases of business, sometimes things like mentoring, access to resources and expertise are much more needed and more valuable than money itself. Most of the founders of the startup companies have no experience in launching business ventures and facing the first time all obstacles that the market and business environment brings. There is no culture in the world in which communities do not play a key role in the development of one society. Community members who provide mutual understanding and support, exchange experiences, receive advice from people more experienced than themselves, associated with the same aim in symbiosis enter further survival and progress [19].

*Business Incubators* - Incubators represent organizations created for founders in the earliest phases of starting a startup venture, for those who have an innovative idea, but they need assistance to set up a business model, legal regulations or market entry [20]. The goal of the incubator is to support the founders in the process of taking innovative ideas and developing them into the Minimum Viable Product – MVP.

*Accelerators* - Unlike incubators, accelerators are primarily focused on technological companies that have far surpassed the initial idea phase, came to the initial product (left the incubator) and have ambition to “speed up” their development. Of course, there are exceptions to this case, so accelerators that accept companies that are only an innovative idea in principle can be found. The accelerator programs are intended to last a certain period of time, commonly it is between three and twelve

months, so that startups pass a certain type of preparation and thus improve their chances of finding the appropriate investor and secured cooperation with it [21].

*Angel Investors* - According to the definition of “Angels investors” most often former entrepreneurs, but this is not always a rule, which have significant amounts of money and are ready to invest in highly risky, but also highly cost-effective ventures [22]. The capital they provide can be a one-time injection of initial money or constant support. In this way, entrepreneurs and owners of small businesses provide missing resources to start operations, and business angels invest funds in these companies, expecting a high annual yield from investing their property, as well as a significant increase in that property in the short term. Business Angels are the most important connection between funding in developing companies, from the very beginning to the stage in which companies are ready to be in the capital market [23]. Based on the reports of national federations, local networks of investors and national associations of risk capital, there are about 34,500 active investors in the form of business angels at the European continent, which invest primarily through local investments and funds [24].

*Risk Capital (Venture Capital - VC) and Private Investment Fund (Private Equity Funds - PEF)* - Venture Capital Funds are defined as funds investing in companies in exchange for proportion. These are companies that invest money collected from private investors with the expectation of achieving high annual returns to their investment. Therefore, risk capital funds invest in innovative companies that promise successful business. The Private Equity Fund is the greater term from the risk capital fund. The risk capital fund, as a rule, refers to the financing of companies at an early stage of development, while Private Equity Fund includes risk capital and additional takeover [25].

Venture Capital Firms - (VCF) and private investment funds (Private Equity Funds - PEF) provide private capital by private investors (indicated by the notion - The Venture Capitalists) for the SMEs, especially those in the initial phases development. It is important to point out that VCF and PEF do not invest its own capital, but funds collected by institutional or individual investors.

It is believed that in addition to the financing role of VCF and PEF, they usually perform two

more roles - monitoring (control and assistance to the organization to develop their business) and exit [26].

Unlike traditional suppliers of capital, risk capital prefers high-risk ventures with a potentially high degree of investment returns, if these innovative ventures successfully overcome the “Death Valley” - the period from initial funding for startup to commercially sustainable. Many regulatory reforms were taken by developed countries, including those on the European continent to ensure the survival and sustainability of market [27].

*Crowdfunding* - Innovative and alternative model of financing new risky ventures, which allows individuals to participate with individual donations and payments in financing for profit, cultural or social projects, often with the aim of gaining future products or owned shares [28]. There are three main participants in the crowdfunding campaign. The first participant is the author of the campaign, so someone who organizes a campaign and collects funds for the realization of its project. The author of the campaign addresses another process participant - Backer or Backes (supporters). Backers are people who support a particular project and campaign authors with their money donations. The whole process takes place on the Internet, via a crowdfunding platform, which is a third participant in the process and intermediary between the campaign and Backer’s authors. We distinguish four types of crowdfunding [29]:

- Donation crowdfunding - is the simplest form. Backer donate to particular campaign and do not expect anything in return.
- Reward Crowdfunding - means that Backer’s for financial support from campaign authors will receive some kind of award.
- Investment crowdfunding or crowd investing - is the investment of financial resources in the campaign, while in turn counts on interest profits.
- Equity Crowdfunding – allows backers to become part-owners of company by buying shares.

The development of the crowdfunding platform has facilitated the campaign by standardizing the process and creating higher visibility of projects.

This in turn accelerated the development of crowdfunding at the international level.

#### IV. EUROPEAN STARTUP ECOSYSTEM SUCCESS FACTORS AND SUPPORT PROGRAMS

Startup companies represent the catalysts of economic development, their innovation encourage market competitiveness to satisfactorily the existing needs of consumers as well as those who are just in their formation. The development of these micro endeavors differs from country to country. Strategic success factors for startup development vary in highly developed countries in relation to those countries trying to compensate existing backlogs. In the 21<sup>st</sup> century, competitive advantage in the company market generates mainly by possessing and implementing resources and skills for faster market needs in relation to competitors.

European startup ecosystems success factors can be divided into eight categories [30]. In accordance with internal growth, these categories include knowledge, human capital, and technological progress that largely depends on the specific company and its commitment. The exceptional importance of human capital is especially emphasized, which manages the process of formation, growth and sustainability of startup companies. Among external independent factors are economic policies of European Union institutions, but also the Member States who set economic, innovation and social base for startup development. In this regard, we come to a conclusion that only the interaction of internal and external factors creates an appropriate “climate” for the success of the startup and the ecosystems they belong to.

##### A. Startup Support Programs in European Union

The European Commission has most contributed to the growth of European startup ecosystems through their funding programs such as Horizon 2020 and Horizon Europe as well as many others.

Horizon 2020 had set aside almost 800 million euros for cascade funding calls. Cascade funding, also known as the financial support to third parties (FSTP), is the mechanism of the European Commission for the Distribution of Public Funds to help users, such as new companies, growing companies, small and medium enterprises in adoption or development of digital innovation [31].

This method of financing aims to simplify administrative procedures, creating a solid application scheme that is suitable for small and medium-sized enterprises. Also, this mechanism allowing some EU-funded projects, in return, open calls for further funding [32].

On the other hand, the European Startup Network (ESN) unites the European National Startup Association to create a joint association for European startups.

European Startup Network helps strengthen European Startup Ecosystem through [33]:

- presentation of the Startup Ecosystem at the level of the European Union (European Commission);
- sharing knowledge and exchange of best European practices;
- creating partnerships between startups, corporations, accelerators, institutions and investors.

New trends in European startup ecosystem are [34]:

1. the rapid increase in funding for the start of business;
2. increased technological expertise;
3. more capital employees;
4. initiatives to strengthen the startup scene;
5. EU policies that empower technological startups.

##### B. Standard EU Startup Nation

New policy, EU Startup Nation Standard, is set to solve the usual problems facing startups, such as employee retention, attracting talents and creating endeavors.

##### C. Innovative Radar Platform

In order to detect the results of its financing innovation, the innovative radar platform aims to identify innovators and innovations of high potential in research and innovation projects.

##### D. Digital Innovation and Scaleup Initiative (DISC)

This policy was set up to counter the investment gap faced by digital startups in central, eastern and southeast regions of Europe by maximizing investment opportunities and beefing up on technical assistance programs.

## V. RESULTS AND DISCUSSION

This research includes the most important parameters of selected countries, and their comparative analysis was performed. These selected parameters indicate the characteristics and financing of these startup ecosystems, in order to obtain a picture of the European startup ecosystem on the basis of this. Research covers the period 2019-2022. and the observed indicators are: value of startup ecosystems and investments in the initial stages of startup business.

By analyzing Fig.1. and the information presented, it can be noticed that for observed states, the value of the startup ecosystem was recorded throughout the year, which in 2021 recorded a decline in this indicator. As a state with the highest values throughout the years is Sweden followed by France and Germany. Although Finland, Ireland, Hungary and Serbia stand out with lower values, there are also a tendency for positive growth through them. The total value of startup ecosystems in 2022 for observed states amounts to over 389 billion dollars, and that is an increase of 200 billion dollars compared to 2021, which is so far the biggest growth.

Fig.2. shows the comparative display of the value of financing in the early stages of starting startup company for the period 2019-2022. At the displayed diagram, it can be noticed that in most countries, funding in the early stages except Hungary, Ireland and Serbia, where fluctuations of this value during the observed period were recorded. The average value of funding startup companies in the initial phases for observed countries in 2022 is over 1.6 billion dollars. The highest amounts of financial assets in the early

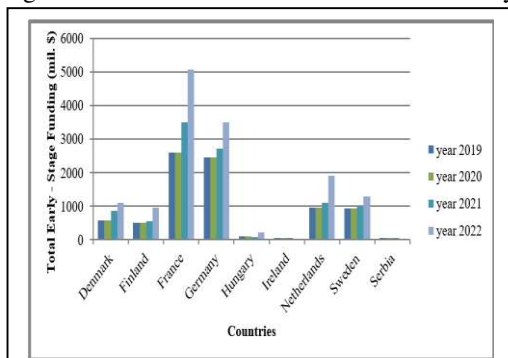

Figure 1. Comparative representation of the Startup Ecosystem value for the period 2019-2022. (Data sources: Startup Genome Reports [13,35,36,37]).

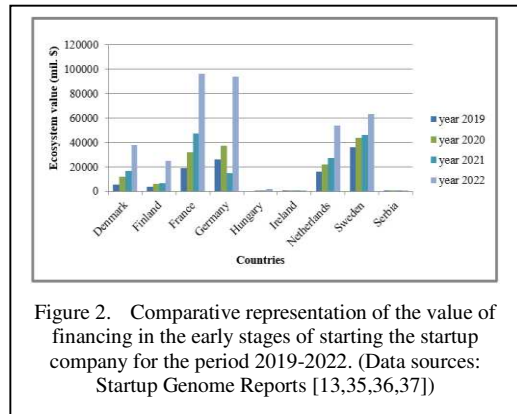

Figure 2. Comparative representation of the value of financing in the early stages of starting the startup company for the period 2019-2022. (Data sources: Startup Genome Reports [13,35,36,37])

stages of starting startup companies were recorded in Germany and France, while the lowest amount was recorded in Serbia and Ireland.

## VI. CONCLUSIONS

The process of developing a new startup company begins with the development and implementation of innovative ideas. However, a good idea is not a sure indicator of the future survival and stability of the new venture. So in addition to the already mentioned ideas, the efforts and commitment of the founders, the appropriate community support, developed entrepreneurial culture of the area from which the company will enter into size and phase in which the startup is located.

While conducting the research, which was set as a basis for this study, it was observed that the European Union has been shown to improve the conditions for the establishment of the startup companies and improving the functioning of ecosystems to catch up with the largest competitors, and they are the United States and China. Efforts can be noticed through numerous legislation adopted in favor of entrepreneurs with the aim of providing further progress and development.

Analysis of data collected based on the Startup Genome Organization for the period from 2019 to 2022 has led to a conclusion that countries have been recorded in significant growth of the value of indicators through the years: France, Germany, Netherlands and Sweden. Considering the success factors of the European startup ecosystem, the obtained results give an even clearer image. The mentioned states invest an intensive effort during years in cultivating and developing innovation, intellectual capital, entrepreneurship, but also

sustainable development, which makes them “fertile soil” for the development of the best startup venture on the European continent.

During the research, certain obstacles in the form of inconsistency of data took place in consideration. Namely, in Startup Genome reports for four observed years in 2019, 2020, 2021 and 2022 there was a change in the methodology. It should also be noted that reports did not cover a number of other European countries, and they were not part of this research. Therefore, in the future, other European countries should be included in these reports, which would lead to more complete and better research. By including more European countries in reports, it would be clearly insight into the reasons for the success of certain startup ecosystems and the prevention of negative consequences caused by turbulences on the market, and especially in the conditions of current crises. Such research, also has practical contributions, primarily in terms of guidelines provided for starting startup companies in the European startup ecosystem, as well as the possibilities of their financing and development.

#### ACKNOWLEDGMENT

The results presented in this paper are part of the research within the project “Improvement of teaching processes at DIEM through the implementation of the results of scientific research in the field of Industrial engineering and management”, Department of Industrial Engineering and Management, Faculty of Technical Sciences in Novi Sad, University of Novi Sad, Republic of Serbia.

#### REFERENCES

- [1] Wennekers, S., & Thurik, R. (1999). Linking entrepreneurship and economic growth. *Small business economics*, 13(1), 27-56.
- [2] Carree, M. A., & Thurik, A. R. (Eds.). (2006). *Entrepreneurship and economic growth*. Cheltenham: Edward Elgar.
- [3] Commission of the European Communities. (2003). *Green Paper: Entrepreneurship in Europe*. Enterprise Directorate-General, Document based on COM (2003) 27 final.
- [4] Forget, E. L. (2002). *The Social Economics of Jean-Baptiste Say: Markets and Virtue*. Routledge.
- [5] Manne, H. G. (2014). *Resurrecting the ghostly entrepreneur. The Review of Austrian Economics*, 27(3), 249-258.
- [6] Drucker, P. F. (1985). *The discipline of innovation. Harvard business review*, 63(3), 67-72.
- [7] Čičovački, T., Kulić, M., & Škorić, S. (2022). Inovacije i preduzetništvo. *XXVIII Skup Trendovi razvoja: “Univerzitetsko obrazovanje za privredu”, Kopaonik*.
- [8] Reis, E. (2011). *The lean startup. Crown Business*, 27, 2016-2020.
- [9] Kollmann, T., Stöckmann, C., Hensellek, S., & Kensbock, J. (2016). *European startup monitor 2016*. Universität Duisburg-Essen Lehrstuhl für E-Business, Graz.
- [10] Blank, S., & Dorf, B. (2012). *The startup owner’s manual: The step-by-step guide for building a great company*. K & S Ranch, Inc, California. PubMed Abstract OpenURL.
- [11] Tripathi, N., Seppänen, P., Boominathan, G., Oivo, M., & Liukkunen, K. (2019). Insights into startup ecosystems through exploration of multi-vocal literature. *Information and Software Technology*, 105, 56-77.
- [12] Isenberg, D. (2011). The entrepreneurship ecosystem strategy as a new paradigm for economic policy: Principles for cultivating entrepreneurship. *Presentation at the Institute of International and European Affairs*, 1(781), 1-13.
- [13] Startup Genome (2020). *The 2020 Global Startup Ecosystem Report*. Available at: <https://startupgenome.com/report/gser2020>.
- [14] Schwienbacher, A., & Larralde, B. (2010). *Crowdfunding of small entrepreneurial ventures*. Handbook of entrepreneurial finance, Oxford University Press, Forthcoming.
- [15] Gordon, J. (2022). *Funding from Friends, Family and Fools – Explained*. The Business Professor. Available at: [https://thebusinessprofessor.com/en\\_US/business-transactions/funding-from-friends-family-and-fools](https://thebusinessprofessor.com/en_US/business-transactions/funding-from-friends-family-and-fools).
- [16] Robinett, J. (2019). *Crack the Funding Code: How Investors Think and What They Need to Hear to Fund Your Startup*. Kindle Edition.
- [17] Ministry of the Republic of Serbia for work, employment, veterans and social issues. (2014). *Priručnik za pripremu i sprovođenje grant projekata*. Available at: [https://www.minrzs.gov.rs/sites/default/files/2021-02/prirucnik\\_za\\_pripremu\\_i\\_sprovodjenje\\_grant\\_projekata.pdf](https://www.minrzs.gov.rs/sites/default/files/2021-02/prirucnik_za_pripremu_i_sprovodjenje_grant_projekata.pdf).
- [18] European Commission (2021). *Horizon Europe*. Available at: [https://research-and-innovation.ec.europa.eu/funding/funding-opportunities/funding-programmes-and-open-calls/horizon-europe\\_en](https://research-and-innovation.ec.europa.eu/funding/funding-opportunities/funding-programmes-and-open-calls/horizon-europe_en).
- [19] Al-Mubarak, H., & Wong, S. F. (2011). How valuable are business incubators? A case illustration of their performance indicators. In *European, Mediterranean & Middle Eastern Conference on Information Systems (Vol. 30)*.
- [20] Aerts, K., Matthyssens, P., & Vandenbempt, K. (2007). Critical role and screening practices of European business incubators. *Technovation*, 27(5), 254-267.
- [21] Cohen, S. (2013). What do accelerators do? Insights from incubators and angels. *Innovations: Technology, Governance, Globalization*, 8(3), pp. 19-25.
- [22] Petković, S. (2021). *Entrepreneurship and Innovation in Digital Era*. University of Banja Luka, Faculty of Economics.
- [23] Giurca Vasilescu, L. (2009). Business angels: potential financial engines for start-ups. *Economic research-Ekonomska istraživanja*, 22(3), pp. 86-98.

- [24] EBAN (2019). *EBAN Statistic Compedium (European early stage market statistics 2019)*. EBAN, Bruxelles.
- [25] Petković, S. & Milanović, M. (2017). *Labaratory of ideas. From an idea to entrepreneurial venture*. University of Banja Luka. Faculty of Economics.
- [26] Metrick, A., & Yasuda, A. (2010). *The economics of private equity funds*. *The Review of Financial Studies*, 23(6), 2303-2341.
- [27] Carvell, S. A., Kim, J. Y., Ma, Q., & Ukhov, A. D. (2013). *Economic and capital market antecedents of venture capital commitments (1960–2010)*. *International Entrepreneurship and Management Journal*, 9(2), 167-182.
- [28] Mollick, E. R. (2013). *Swept away by the crowd? Crowdfunding, venture capital, and the selection of entrepreneurs*. Venture Capital, and the Selection of Entrepreneurs.
- [29] Crowdfunding.rs. (2017). *Četiri modela grupnog finansiranja*. Available at: <https://www.crowdfunding.rs/crowdfunding>.
- [30] Skawińska, E., & Zalewski, R. I. (2020). Success factors of startups in the EU—A comparative study. *Sustainability*, 12(19), 8200.
- [31] EUCalls (2021). *Financial Support to Third Parties: An Introduction*. Available at: <https://eucalls.net/blog/financial-support-third-parties>.
- [32] European Commission (2022). *Funding & tenders opportunities*. Available at: <https://ec.europa.eu/info/funding-tenders/opportunities/portal/screen/home>.
- [33] European Startup Network (ESN) (2022). *Publications*. Available at: <https://europeanstartapnetwork.eu/publications/>.
- [34] Scaler8 (2022). *5 EU Startup Growth Investment Trends To Spot in 2022*. Available at: <https://scaler8.com/insight/5-eu-startup-investment-trends-to-spot-in-2022/>.
- [35] Startup Genome (2019). *Global Startup Ecosystem Report 2019*. Available at: <https://startupgenome.com/reports/global-startup-ecosystem-report-2019>.
- [36] Startup Genome (2021). *The Global Startup Ecosystem Report GSER 2021*. Available at: <https://startupgenome.com/reports/gser2021>.
- [37] Startup Genome (2022). *The Global Startup Ecosystem Report GSER 2022*. Available at: <https://startupgenome.com/reports/gser2022>.

# Intellectual Capital and Emergencies

Jelena Malenović-Nikolić<sup>1</sup>, Uglješa Jovanović<sup>2</sup>

<sup>1,2</sup>Faculty of Occupational Safety, Niš, Serbia

<sup>1</sup>malenovicfnrr@gmail.com, <sup>2</sup>ugljesa.jovanovic@znrfak.ni.ac.rs

**Abstract**—Intellectual capital, as a resource ensuring competitive advantage and providing a basis for proper knowledge management, can greatly contribute to prevention of emergencies. Modern economy is based on material and non-material resources (knowledge). Possession of information and individuals' ability to efficiently and timely utilize the information are essential for the mitigation of negative environmental impacts. The previous values of material economy (real estate and money) are gradually being replaced by new ones, such as gold and uranium. Prevention of emergencies caused by exploitation of uranium reserves and increased radioactivity can also be based on the elements of modern economics. This requires adequate use of intellectual capital in the form of individual competencies and internal capital, in order to efficiently use national uranium resources and mitigate the effects of natural radioactivity. This paper discusses the increased concentrations of natural radioactivity in the area covered by Mount Stara Planina. Additional problems include the presence of an improperly shut down uranium mine and the presence of uranium tailings around the mine, in the vicinity of the villages of Gabrovnica and Mezdreja. These problems are considered as potential emergencies. The foundation for creating added material value together with the simultaneous solution of accumulated environmental issues, is to utilize the experience, capabilities, and skills, or competences, as the elements of human capital, and to collect the measured results in databases (internal capital).

**Keywords** – intellectual capital, emergencies, risk assessment

## I. INTRODUCTION

Intellectual capital management is directly associated with knowledge development. The importance of organizational-social capital is in that it causes people to work together successfully to accomplish tasks [1,2]. Intellectual capital is one of the relatively modern

concepts that are increasingly relevant in terms of concept and measurement [3]. Radioactivity, the property of chemical elements or substances to emit invisible high-energy particles or rays, has a negative impact on the fundamental elements of the environment – flora and fauna. As a natural radioactive element, uranium is present in high concentrations in minerals and in lower concentrations in water, plants, animals, humans, and rocks. In addition to uranium, natural world also contains isotopes of plutonium, the naturally occurring element with the highest atomic mass. Natural radiation in the form of Earth's crust radiation originates from naturally occurring radioactive elements in clay substrates, rocks, and soil. Radioactive substances accumulate in water, soil, and sediments, and the radiation is characteristic of different parts of the Earth and usually the most prominent above uranium ore deposits. Combination of such knowledge with the possibility of adequately applying it facilitates the analysis of the effects of natural and artificial radioactivity.

The major radioactive materials in rocks include potassium, rubidium, and the radioactive elements formed by the decay of uranium and thorium. Individual knowledge of these facts is not considered intellectual capital [4], because individuals who possess knowledge without applying it do not contribute to development and do not create material or non-material values. Discovery theory refers to the systematic scanning of the environment to discover possibilities for creating new products and/or services [5].

## II. KNOWLEDGE AND INFORMATION AS THE BASIS OF INTELLECTUAL CAPITAL

With the entirety of their individual and collective knowledge, individuals are considered human capital only when they transform their



knowledge into specific activities aimed at solving specific observed problems. The basic information about uranium that an individual possesses is only a portion of professional competence, as the example below will demonstrate.

Uranium, a radioactive chemical element present on Earth since its formation, occurs as a mixture of three uranium radionuclides:  $^{238}\text{U}$  – 99.2745%,  $^{234}\text{U}$  – 0.0055%, and  $^{235}\text{U}$  – 0.7200% [6]. It has been studied for over a century by experts in the fields of radiation, mining, geology, paedology, physics, chemistry, biology, and technology, primarily because of its physical (nuclear), chemical, geological (radiochemical and geochemical), toxic, and ecological properties [6]. Studies indicate that scientists have gained knowledge, capabilities, and experience, as the foundations of human capital. The most frequent area of study regarding uranium is the transformation of the atomic nucleus and the occurrence of ionizing radiation during the formation of new chemical nuclei. It was discovered that uranium nuclear transformations are accompanied by significant energy transformations, which initiated the period of nuclear energy exploitation. Investigations of uranium application show that professional competences of employees have been converted to collective knowledge, which remains company property.

Research has advanced over time and collective knowledge has reached significant heights, which is evident from the following facts. Uranium is widespread and can be found in the basic environmental elements. It is present in small concentrations in foods for humans and animals, whereas higher uranium concentrations, i.e., larger uranium deposits in nature, depend on redox processes in the presence of oxygen and organic matter [6].

In nature, uranium forms chemical compounds with other elements in the environment, even though it is very inert and poorly soluble in water. ‘Inert’ uranium, which has around 97%-presence in nature [6], is not typical of migration processes through ecosystems and biological communities. The problem of uranium oxidation and transition into hexavalent uranium refers to the formation of water-soluble compounds. The remaining uranium, present in the range from 0.1 to 3% [6], is categorized as the so-called ‘mobile’ uranium, because it migrates easily and has an ecological

and biological significance. Its migration from the soil into plants proceeds through ion exchange [6] and results in complex compounds that it forms with organic acids from the soil or secreted from the plant roots. The stated facts indicate that employee competences when studying uranium transformations are not negligible, since changes under specific circumstances were monitored, accompanied by socially acceptable behavior (team work).

The ability of employees to direct their research toward creating value and shared results is verified by the existence of professional competences, as seen in the following example. Prevention of uranium migration is possible if the hexavalent uranium ( $\text{U6}$ ) is reduced to tetravalent ( $\text{U4}$ ), weakly soluble ‘inert’ uranium [6]. This process is an important destabilizer of environmental systems, although a portion of uranium is lost through oxidation. Hexavalent uranium is easily drained by precipitation but it reaches water courses and is scattered via deposited sediment.

Reduced uranium concentrations in rocks and increased concentrations in water sediment pose even more serious environmental problems. Uranium concentrations in sediments also increase because of the physical and chemical processes of erosion, which accelerate uranium transport. Erosion processes are responsible for significant uranium ore deposits over the previous two to three billion years, and one of those processes occurred in Mount Stara Planina (lit. old mountain) nature park, the Serbian portion of the Balkan mountain range. Investigating a problem in a specific territory and applying scientific knowledge is a confirmation of concrete results, wherein rational capital includes relations with the external environment.

Rational capital based on specific job assignment and higher autonomy of lower organizational structures leads to higher individual values of a system. An investigation of a single issue from different perspectives suggests that the problems of defining uranium reserves, analyzing chain reactions, and determining the effects of mining are solved using a systems approach. Nowadays, it is estimated that the total uranium ore reserves amount to appr.  $5 \cdot 10^6$  tonnes, and that one tonne of uranium in nature contains 992.9kg of  $^{238}\text{U}$ , 7.1kg of  $^{235}\text{U}$ , and 0.54kg of  $^{234}\text{U}$ , when the isotopes in the mixture are balanced [6]. It is also estimated that ocean waters contain considerably

more uranium (appr.  $5 \cdot 10^9$  t), but the issue is the complicated process of underwater extraction, which poses substantial risk to marine life.

Four billion years ago, natural redox processes created the ‘natural nuclear reactors’, in which a chain reaction occurred. These reactors contained several tonnes of uranium oxides with 2% of  $^{235}\text{U}$ . The surrounding water served as the neutron moderator and the coolant for the reactor core. The content of fission products was about 7%, while the ratio of  $^{235}\text{U}$  and  $^{238}\text{U}$  in the reactors was 0.001–0.002. The life span of these reactors is 100 years when they are cooled. The leftover uranium fuel was found to contain 0.2%  $^{235}\text{U}$ , which means that the fuel was ‘depleted’ during the fission reaction [6].

The organization of studying natural processes should be defined in such a way that every aspect of observation is given sufficient attention, from the moment a specific occurrence has been registered. The first natural nuclear reactor with leftover depleted uranium was found in Gabon, where six reactor cores were discovered. In addition, the water that washed the mine shafts was found to contain amino acids and hydrogen peroxide [7], which indicates that the ionizing radiation from the shafts caused the polymerization of C, H, N, and O atoms and radiation-chemical processes, i.e., water radiolysis [8]. In this case, it is necessary to base intellectual capital on proper knowledge of physical, chemical, radiation, and biochemical processes. It is well known that the following processes occur in nature as well as during laboratory tests [6]:

- physical processes (uranium nuclear fission);
- chemical processes (synthesis of compounds and polymerization of molecules);
- radiation processes (water radiolysis); and
- biochemical processes (formation of organic macromolecules).

The technological procedures for transforming natural into depleted uranium were discovered much later compared with the natural processes. The knowledge of processes of natural transformation of radioactive elements constitutes an individual collective value of a system in the form of human capital. To determine the probability of emergencies, it is

important to include qualified and capable personnel in the assessment team, because their intellectual input is vital for proper assessment.

### III. STRUCTURAL CAPITAL AND URANIUM DEPOSITS

Databases, patents, organizational schematics, and projects form the basis of structural capital, which also serves as support for the development of human capital (Fig.1). Structural capital implies the use of information technology in logical processes, so in this case it is based on the application of available data on uranium deposits distribution and measured concentrations. Uranium deposits were also formed in the territory of present-day Serbia several billion years ago due to various physical and chemical processes. There are multiple geological areas containing uranium in higher or lower concentrations, with igneous, sedimentary, carbonate, and granite rocks as the main sources. Geological research of uranium uncovered uranium deposits in and around the following locations: villages of Gornjane, Brnjica, and Neresnica; the Homolje Mountains; Prokuplje; Stara Planina; Mount Bukulja; Cer and Iverak mountains; the South, the West, and the Great Morava basin; Mount Jastrebac, the Jablanica River; the Pusta River; Vranje; Mount Besna Kobila; and Bosilegrad [9]. Organizational capital of the team that assesses the possibility of an emergency is an important element of structural capital. It involves the organizational structure of the team, which is expected to properly apply the existing databases and intellectual documentation.

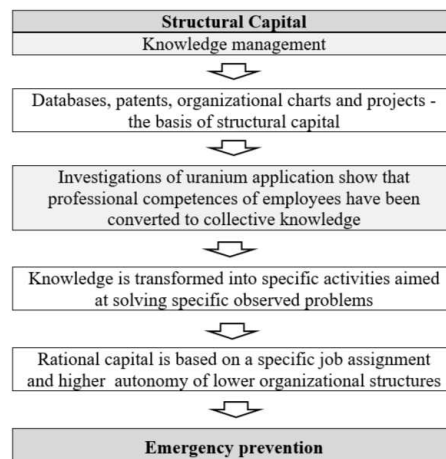

Figure 1. Structural capital and emergency prevention scheme

#### IV. ORGANIZATIONAL CAPITAL AND RISK ASSESSMENT

Organizational capital, which is based on innovation, process, and consumer capital, can have a very important role in assessing the effects of uranium radioactivity in specific areas. Innovation capital, as the ability of a team to respond constructively to when solving current issues, implies flexibility when there is a need to change the organizational structure, attitudes, and work processes focusing on the determination of real values of uranium concentrations. The analysis of uranium properties (physical, biochemical, and radioactive) revealed that uranium is a toxic and radioactive chemical element. Uranium deposits have high concentrations of radioactive matter, so the high risk to the surrounding living organisms has to be considered. The innovation processes need to be based on applicable knowledge and constant improvement, considering the seriousness of radioactivity effects.

Sediments and rocks are the main sources of uranium in nature. Uranium concentrations in water depend on the concentrations in soil and sediment as well as on the solubility of uranium compounds. The data on the natural distribution of uranium and the geochemical composition of soil indicate 'zero state' values of a given area, which is the basis for the newly-introduced uranium risk assessment for the given area.

Transformation of uranium within the technological processes that exploit its radioactive components leads to even more significant negative impacts on all environmental elements. Indirectly, increase of uranium concentrations in water and soil harms the health of humans and reduces their quality of life. Constant improvement is necessary, coupled with the inclusion of professionals, in order to improve not only intellectual capital but also the reliability of assessing the level of environmental quality degradation.

A monitoring system for water and soil can determine uranium distribution and define its migration flows. Intellectual capital management, which is based on a culture of motivation, innovation, and constant improvement, is crucial for the organization of a monitoring system. The results could also be used to determine the following aspects:

- uranium concentrations;
- activities of uranium within the basic environmental elements and the food intended for human and animal use;
- adequate bioindicators; and
- radioecological 'capacity' of a given area to withstand additional amounts of uranium.

Among other things, the clearly set goals by the emergency assessment team leader need to include the consideration of the impact of adequate technological processes, use of artificial fertilizers, coal burning, and the impact of tailings ponds and ash deposits. Mining is one of the major causes of elevation of naturally-occurring radionuclide material concentrations on the Earth's surface [7]. The aim of study [7] was to evaluate the human risk associated with exposure in soils from mine tailings around. The RESidual RADioactivity (RESRAD) OFFSITE modeling program (version 3.1) was then used to estimate the radiation doses and the cancer morbidity risk [7]. The study presented the cancer morbidity risk from all radionuclides (238U, 232Th, and 40K) and all pathways summed during 100 years with sensitivity analysis on cover depth [7,9].

Sources of uranium also include the technological processes of mineral fertilizer production, phosphoric acid production, phosphogypsum generation, coal combustion, and disposal of ashes containing radioactive matter.

Uranium presence in coals depends on the type and origin of coal and ranges from 15 to 50.8 g/kg [10], as shown in Table I.

Management is an important link between human, organizational, and consumer capital, which is why it is necessary for a real assessment of the state of the environment. The data shown in Table I indicate that uranium activity in coals in Serbia is by no means negligible.

TABLE I. AVERAGE URANIUM ACTIVITY [10]

Material	Activity [g/kg]
Coal	15-50.8
Coal in Serbia	40.8
Ash and slag	40-140.8
Fly ash	150.8

The biggest problem is the uranium activity in slag and ash, because the ash deposit sites are directly surrounded by agricultural land. Scattering of ash and emissions of fly ash cause air pollution. Considering the aforementioned environmental issues, it is understandable that ash deposits are classified as hazardous waste dumps and potential radioactive sources.

The team assessing the possibility of an emergency needs to consider all possible hazards in order to give a proper assessment and provide the expected service to information users. Efficient value creation depends on the possibility of prompt response and prevention of serious consequences. If a team is satisfied with the completed work without having provided a proper assessment, it may be a strong indication of oversights in strategic and operational activities.

#### V. INDIVIDUAL COMPETENCES IN THE ASSESSMENT OF ENVIRONMENTAL QUALITY DEGRADATION

Individual work in an emergency assessment team helps create visible and invisible values, depending on the degree of individual competences. Environmental degradation assessment should be performed by persons with adequate education and significant work experience. Assessment results largely depend on the individual competences of technical personnel, experts, and team leader, especially when protected areas are concerned. The area of Mount Stara Planina was designated a nature park in 1997, but it is also specific for its natural occurrences and deposits of uranium [6], as shown in Table II.

The area of Stara Planina is characterized by two levels of radioactivity [6], with the limit of 500 cps (counts per second). Examinations of radioactivity around entrances into the abandoned mines revealed higher radioactivity levels in Gabrovnica, Mezdreja, Novo Korito, as well as in the watercourse of the Trgoviški Timok.

The analysis of internal data based on the use of concepts, computer systems, and administrative processes indicates that team members need to direct their activities toward creating adequate internal structure in order to identify key issues caused by natural and anthropogenic events. The main sources of radioactivity on Stara Planina are classified as [6]:

TABLE II. REGIONALIZATION OF URANIUM OCCURRENCES AND DEPOSITS [10]

Uranium deposits	Uranium occurrences
Janje granite orefield	Janje granite orefield
Infiltration	Crni Vrh series orefield
/	Inovo series orefield
Colorful series orefield	Colorful series orefield

- Granite endogenous – syngenetic occurrences and deposits;
- Metamorphogenic – syngenetic; and
- Sedimentary originating from fluctuation of uranium deposits by water in various types of sedimentary rocks formed in the continental environment, which could be classified as epigenetic types.

The four analyzed samples from the Mezdreja location are described below [11-13]:

- A granite sample was taken near the pit. The GR110 device registered 520 cps at the sampling site and 420 cps and 0.322  $\mu\text{Sv/h}$  at the pit entrance. The pit has been covered and can no longer be entered. The rock is partially cracked.
- Small offshoots of silicified material were observed in the area from the pit entrance to the tailings pond. The registered radioactivity was 320 cps and 0.182  $\mu\text{Sv/h}$ .
- Radioactivity at the tailings pond was up to 1250 cps and 0.421  $\mu\text{Sv/h}$ .
- A sample taken at the interface of granite and gabbro showed the radioactivity level of 120 cps and 0.192  $\mu\text{Sv/h}$ .

The Gabrovnica uranium deposit has a similar genesis to that in Mezdreja, and the uranium ore has developed in crushed granites. The samples included fresh granite [6] near the pit (240 cps and 0.210  $\mu\text{Sv/h}$ ) and granite from the tailings pond (360 cps and 0.248  $\mu\text{Sv/h}$ ), whereby lower values were registered for the Grabovnica site.

At the Mezdreja mine, only test unearthing was performed, whereas almost all of the ore was unearthed at the Gabrovnica mine. The ore was processed [11-13] at Mezdreja (capacity of

60 t/day) and Gabrovnica (capacity of 200 t/day) mines.

The collected data, as elements of internal structure, are predominantly based on a well-organized monitoring system, but they should also include the element of uncertainty [14], owing to the influence of various factors at measurement locations.

## VI. INTELLECTUAL CAPITAL IN EMERGENCY PREVENTION

Emergencies are established through actions, declarations, and management in the event of threats to material and natural resources and the environment from natural disasters, technical and technological accidents, and other disasters (Fig.2), as stipulated by the Law on Emergencies [15]. The analysis of the impact of radioactivity on Stara Planina indicated that there is increased radioactivity specifically around the abandoned Mezdreja and Gabrovnica mines, in the area of Inovo schist, and in the area of Jelovica-Dojkinci red sandstone. Solution of the observed problems using databases and individual knowledge and experience, but by ensuring material gains based on uranium reserves, meets the need for utilizing natural (uranium reserves) and intellectual (qualified personnel) resources of the country by relying on intellectual capital.

The Emergency Protection and Rescue Plan is used to plan preventive and operating measures for the prevention and mitigation of the effects for the purpose of protection and rescue of people and property and provision of basic living conditions, all on the basis of threat assessment. Modern economy necessitates the use of knowledge, so that efficient knowledge management may also generate profit, reduce the level of environmental pollution, and prevent emergencies.

Measurement results show that Serbia possesses considerable uranium reserves, which could lead to an increase of material value. Natural concentrations of uranium in granite range from 6.5 to 20.09 cpm, and the values are increased by 1.5 to almost 5 times compared to the natural uranium distribution in granite. The measured maximum natural concentrations of uranium in the offshoot of graphitic schist of the Inovo series was 27.31 cpm, which is 18.2 times higher than the average uranium concentration (1.5 cpm). The gamma absorbed dose is 5.4 times higher than the global average. Grey aleurolites of the colorful series contain the measured

maximum of 54.43 cpm of uranium, which is almost 22 times higher than the average uranium content in sedimentary rocks. The gamma absorbed dose is 3.3 times higher than the global average [6,11].

Uranium concentrations also point to environmental issues that require immediate attention. According to the Law on Emergencies [15], an emergency may be declared after the fact if the immediate danger of its onset could not have been predicted or if, owing to other circumstances, it could not have been declared

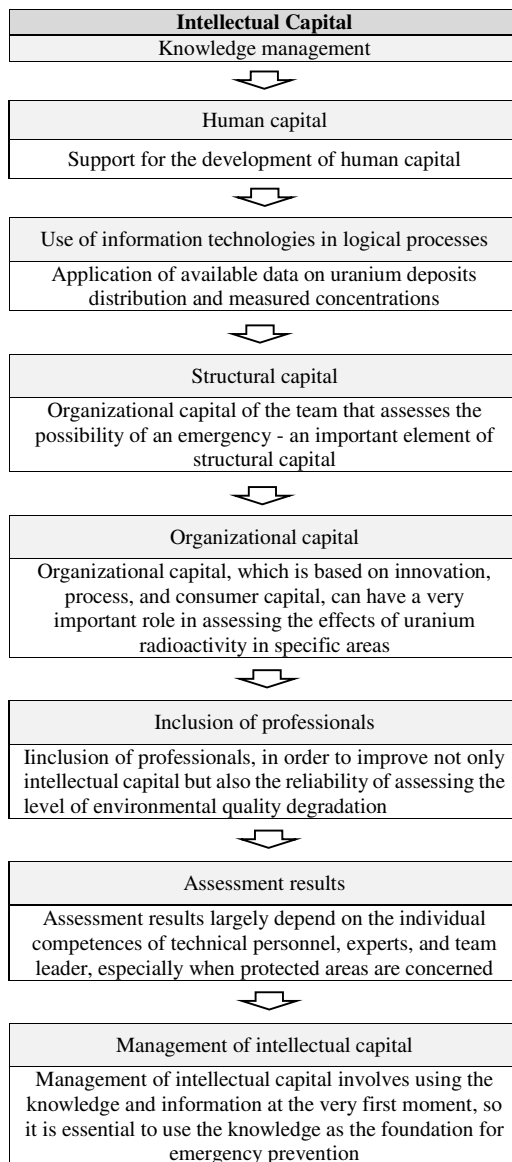

Figure 2. Structural capital and emergency prevention scheme

momentarily after learning about the immediate danger of its onset. Accordingly, the actual situation must always be considered. According to the Law on Radiation and Nuclear Safety and Security [18], systematic monitoring of environmental radioactivity is conducted in order to determine the presence of radionuclides in the environment and to assess the level of human exposure to ionizing radiation in normal circumstances, in the event of a suspected accident, and during an accident.

Radioactivity monitoring results for environmental samples are published within the annual reports on the population's exposure to ionizing radiation. In Serbia, the gamma ambient dose equivalent rate is monitored in Belgrade, Vinča, Golubac, Zaječar, Lazarevac, Kladovo, Kragujevac, Novi Sad, Niš, Obrenovac, Palić, Pirot, Prahovo, Sremska Mitrovica, Kraljevo, and Užice. Air sampling for radionuclide content examination is conducted in Belgrade, Vinča, Subotica (Palić), Niš, Zlatibor, Zaječar, and Vranje. Samples of solid and liquid precipitation are collected daily and continuously over the 24 hours in Belgrade, Vinča, Subotica (Palić), Novi Sad, Niš, Zaječar, Kragujevac, Zlatibor, and Vranje. Samples of staple foods and dairy products are collected in Belgrade, Subotica, Novi Sad, Niš, Užice (Zlatibor), Zaječar, and Vranje [16].

Surface water samples are collected daily from the Danube in Bezdan, Zemun, Vinča, and Prahovo; from the Sava in Sremska Mitrovica and Belgrade; from the Nišava in Pirot; from the Tisa in Kanjiža; from the Timok in Knjaževac; and from the Drina in Loznica. Drinking water samples are collected daily from water utilities that supply water to settlements larger than 100,000 people. In 2021, drinking water samples were collected in Belgrade, Niš, Subotica, Kragujevac, Čačak, Kraljevo, and Leskovac [13]. Attention should also be given to the leachate from the abandoned uranium mines Mezdreja and Gabrovnica. The leachate from graphitic schists is drained into the watercourses of the Crnovrška, Gabrovnicka, and Inovska rivers, but also into the water of the Trgoviški Timok, which flows through limestone, all of which warrants the analysis of samples from the said watercourses. It is also necessary to examine the status of the watercourse at the confluence of the Crnovrška into the Trgoviški Timok in the village of Balta Berilovac.

The observed issues reveal the fact that much is known about the issues but that little is being done to minimize the effects. The aim of this paper is to draw attention to the possibility of deriving benefit from uranium reserves through proper use of intellectual capital. The analyzed data indicate that uranium and radium are usually in equilibrium, which suggests that there is no significant uranium migration. The problem is that specific locations contain uranium concentrations that exceed radium concentrations, indicating that the deposition processes are still ongoing. Uranium accumulation and formation of infiltration uranium deposits are by no means completed processes, so it is necessary to monitor the values of radioactive materials on Stara Planina, specifically in Gabrovnica, Mezdreja, Inova, and in the Trgoviški Timok around the village of Kalna.

Encouraging professionals to apply their intellectual capital to creating values and solving environmental issues will result in adherence to the basic principles of sustainable development.

## VII. CONCLUSION

It is necessary to base the solutions to environmental issues on efficient knowledge management as well as on recognition of individual competences within the professional community. The need to expand knowledge, to adopt new technologies, and to share individual experiences will lead to successful solution of environmental issues by means of modern economy. Prevention of emergencies based on the analysis of radioactivity data indicates that immediate action was not taken and that there is a need to resolutely and promptly determine and mitigate the serious effects of natural and anthropogenic radioactivity on Mount Stara Planina. Monitoring of radioactivity as a regularly occurring phenomenon and the presence of uranium deposits requires a re-evaluation and definition of corrective measures to reduce the negative impact. Anthropogenic impact on radioactivity levels is evident, as confirmed by the values of radioelements. The problem also needs to be addressed by declaring an emergency in order to allow the reclamation of tailings ponds and block the transport of radioactive materials into the environment of the surrounding villages. Red sandstones also contain uranium, which is transported further through leachate and watercourses.

Management of intellectual capital involves using the knowledge and information at the very first moment, so it is essential to use the knowledge as the foundation for emergency prevention.

Recognition of individual potential and its utilization within interdisciplinary teams leads to the use of human capital in creating new values when minimizing the effects of negative anthropogenic activity.

#### ACKNOWLEDGMENT

The presented research is funded by the Ministry of Education, Science and Technological Development of the Republic of Serbia.

#### REFERENCES

- [1] Allameh, S. (2018). Antecedents and consequences of intellectual capital. *Journal of Intellectual Capital*, 19(5), 858–874
- [2] Ali, S., Murtaza, G., Jiang, J., & Naeem, M. (2022). Intellectual capital and financial performance: A comparative study. *Frontiers in Psychology*, 4672.
- [3] Nishanthini, A., & Arthika, R. (2021). The Impact of Intellectual Capital on Financial Performance: A Study of Sri Lankan Financial Institution. *International Journal of Multidisciplinary Research and Analysis*, 4(9), 1342-1348.
- [4] Sunač, D., & Ftur, I. (2004). Intellectual capital [Intelektualni kapital]. *Ekonomski pregled*.
- [5] Ognjanović, J., & Slavković, M. (2022). Intellectual capital and financial performance of entrepreneurs in the hotel industry. *Hotel and Tourism Management*, 10(1).
- [6] Abdulqader, S. A. (2017). *Characteristics of natural and antropogenically developed radioactivity of the Stara Planina mt. and its environmental impact* [Karakteristike prirodne i antropogeno izazvane radioaktivnosti Stare planine i njen uticaj na životnu sredinu]. Doctoral dissertation, Singidunum university, Faculty of applied ecology Futura, Belgrade.
- [7] Mathuthu, M., Kamunda, C., & Madhuku, M. (2016). Modelling of radiological health risks from gold mine tailings in Wonderfontein spruit catchment area, South Africa. *International Journal of Environmental Research and Public Health*, 13(6), 570.
- [8] Meija, J., et al. (2016). Atomic weights of the elements 2013. *IUPAC Technical Report*.
- [9] Momčilović, M., Kovačević, J., & Dragović, S. (2010). Population doses from terrestrial exposure in the vicinity of abandoned uranium mines in Serbia. *Radiation Measurements*, 45(2), 225-230.
- [10] Muto, T., Hirono, S., & Kurata, H. (1965). Some aspects of fixation of uranium from natural waters. *Mining Geology*, 15(74), 287-298.
- [11] Nikić, Z., Letić, L., Kovačević, J., & Nikolić, V. (2013). State of elements of the environment in the broader area of former uranium mines in the catchment of the Trgoviski Timok. *Glasnik Šumarskog fakulteta*, (107), 163-174.
- [12] Nikic, Z., Kovacevic, J., & Papic, P. (2008). Uranium in the groundwater of Permo-Triassic aquifers of the Visok region, Stara Planina, eastern Serbia. *Water, air, and soil pollution*, 192, 47-58.
- [13] Nikić, Z., Kovačević, J., & Radošević, B. (2002). Uranium content in ground water in Stara Planina Triassic sediments. In *Proceedings of the International Conference on Uranium Mining and Hydrogeology III and the International Mine Water Association Symposium, Freiberg* (pp. 99-106).
- [14] Peng, X., Min, M., Qiao, H., Wang, J., & Fayek, M. (2015). Uranium-series disequilibria in the groundwater of the Shihongtan sandstone-hosted uranium deposit, NW China. *Minerals*, 6(1), 3.
- [15] Law on Emergencies, Official Gazette of the RS, No. 111/2009, 92/2011, and 93/2012.
- [16] Republika Srbija, Ministarstvo zaštite životne sredine, Sektor za nadzor i predostrožnost u životnoj sredini (2019). *Izveštaj o radu inspekcije za zaštitu od jonizujućih zračenja za 2018. godinu*.
- [17] Law on Radiation and Nuclear Safety and Security (Official Gazette of the RS, No. 95/18 and 10/19)

# Performance Quality: A Measure of Organizational Complexity

Dragoljub Šarović<sup>1</sup>

<sup>1</sup>Montenegrin Association for Risk Management, Malo brdo L1/37, Podgorica, Montenegro

<sup>1</sup>dragansarovic@mafrm.me

**Abstract**—The total production costs change depending on the quantity of scrap and waste reduction costs. As the quantity of scrap is reduced, production costs are also reduced. When that percentage starts to approach zero, costs begin to rise. This implies that there is an optimal percentage of scrap and an optimal organizational complexity for which production costs are minimal. An organization is able to maintain the optimal quantity of scrap by using the PDCA (Plan, Do, Control, Act) improvement cycle. However, this will be of no help if in the meantime the competition finds a way to manage costs more efficiently and thus overtake the position of the said organization on the market. This paper therefore suggests that the organization, by applying a creative approach - the PDCA cycle of improvement and performance evaluation, should aim to reach the ideal goal: the reduction of the optimal quantity of scrap to zero without additional costs, whereby the total production costs are reduced to the basic production costs only. It is likely that the organization can achieve the ideal goal over time, by implementing many different types of creative PDCA improvement cycles. The corresponding level of organizational complexity which is related to the complexity of the external context approaches the ideal organizational complexity. In order to face the organization with the growing complexity of the external context, this work uses the Luhmann's approach, according to which the system will never be as complex as its environment.

**Keywords** - ideal goal, ideal complexity, performance, creativity

## I. INTRODUCTION

Creativity is related to motivation and it is the driving force for the improvement of the process. The complementarity of creativity and work

standardization holds enormous potential for discovering greater methods of performing the work. The most important indicators of the successful operation of an organization are quality, productivity and costs. When it comes to the relationship between productivity and quality we can use Edward Deming's statement: "productivity grows in parallel with quality". The relationship between productivity or costs and quality is observed through the process of production, which means that the increase of productivity makes no sense if the products are of low quality [1].

The first important question which arises in this work is whether the organization can achieve what Kondo calls the "ideal" ("ultimate") goal [1]. In other words, can the percentage of non-conforming products be reduced to zero, whereby production costs would be reduced only to basic costs? To reach the ideal goal, this paper recommends the use of creative approach and the PDCA (Plan, Do, Check, Act) improvement cycle.

Schwandt states that the top management of the organization tries to strike the balance between reducing and increasing the organizational complexity. Simultaneously, the management tends to adapt the organization in accordance with the influence of the growing complexity of the external context [2]. This means that the level of organizational complexity can be too high and may lead to a decrease of profit, flexibility and negative quality of product performance. In addition, the organization can become inflexible due to its simplicity, which results in the incompetence to deal with the complexity of the external context.



Therefore, this paper asks two more questions: Is there an optimal level of organizational complexity, and if there is, is it sufficient to achieve a competitive advantage? How does the level of organizational complexity affect the quality of product performance?

In order to consider these issues this paper uses both Luhmann's approach and the hypothetical relationship between organizational complexity and performance, graphically presented in the form of an inverse letter "U" [2]. Moreover, a greatly important tool from the ISO 9001:2015 standard, known as performance evaluation, was used. At the same time, a relative definition of complexity is given: System complexity is a function of the number of elements, the number of mutual interactions between elements, the complexity of the elements of the system and the complexity of their interactions [3].

The purpose of this work is expressed through two statements. The first one is that top management can lead the organization towards reaching the ideal goal by creating the conditions for the "wasteful" expression of employees' creativity in the process of production. Another one is that top management can improve the quality of performance by improving organizational complexity (which creates value) and its connection with the complexity of the external context.

## II. METHODS

Here are presented the methods and tools used to answer the questions posed in the introduction of the paper. The ISO 9001:2015 standard requires the evaluation of system and process performance in order to achieve strategic goals. Internal checks and reviews conducted by the top management improve the processes in the organization.

There are always more methods to improve quality of the product. In addition, there is always a space to improve the method which is currently been used, by practicing the creative approach. The conclusion that follows from the abovementioned is that the corresponding costs are variable. It is on this variability that the concept/idea of improvement is based.

In order that a creative approach gives the best possible results, top management needs to create the conditions for the full "release" of employees' creativity, as follows: before

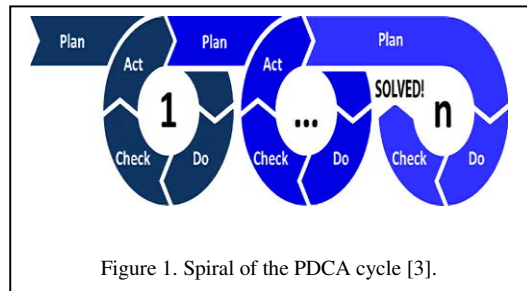

Figure 1. Spiral of the PDCA cycle [3].

performing the work, it is necessary to communicate a clear and realistic goal of the task, to work persistently on creating a sense of responsibility of the employees towards the job, to plan time which is necessary for expressing the new ideas, to enable new ideas to become reality [1].

By applying the PDCA methodology (Fig.1), which is based on a repetitive cycle of activities and monitoring, we create prerequisites for constant improvements and effective management of processes. The purpose of using these methods and tools is a quality assessment of users' satisfaction with the achieved performance.

According to Ishikawa Kaoru, the quality is divided into two categories: positive and negative. The first category refers to the positive characteristics that make it superior to the competition. The second refers to defects, omissions and deficiencies [1].

To consider the first question from the introduction of this paper, we should analyze a graphic representation of the relationship between production costs and the quantity of inappropriate products (Fig.2). It can be seen that the costs of scrap (amounts of non-conforming products and finishing) decrease almost proportionally with the reduction of the quantity of scrap. Simultaneously, the costs of reduction of scrap are growing intensively. Therefore, the total costs of production initially decrease with the reduction of the quantity of scrap. However, when that percentage starts to approach zero, they start to grow. Therefore, there is an optimal percentage of scrap for which costs of production are minimal.

If the top management additionally reduces the quantity of scrap by empowering the creativity of employee and using PDCA cycle, internal checks, review and evaluation of performance, then the value of total costs of

production and the optimal amount of non-conforming products will decrease (as it is shown by dashed lines in Fig.2).

If the employees express additional creativity, it is possible that the total costs of production equalize with the basic costs of production. Simultaneously, the optimal quantity of non-conforming products will be reduced to zero. That is the ideal (ultimate) goal [1].

To consider the second and third questions from the introduction of the paper, we use the Luhmann's approach to simplicity (Fig.3), and the hypothetical relationship between organizational complexity and performance (Fig.4).

Due to the growing complexity of the external context, the increased pressure of selection results in simpler patterns of selectivity, until they become mechanical (based on simplified cause-and-effect relationships). As a result of the pressure of selection and cause-and-effect (mechanical) decisions, the complexity of the system is reduced to a level that ensures a positive performance quality [2]. The pressure of selection means the pressure of the external context of the organization that guides its evolution in a certain direction. Fig.4 shows the hypothetical relationship between organizational complexity and performance.

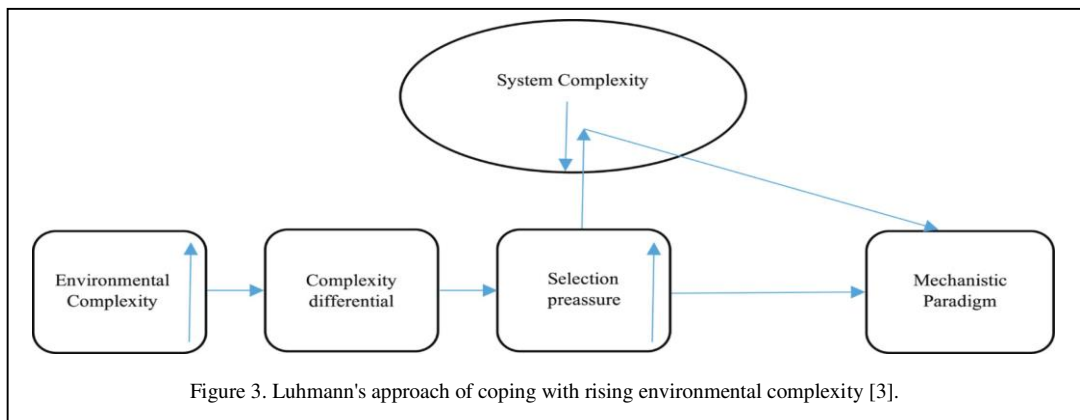
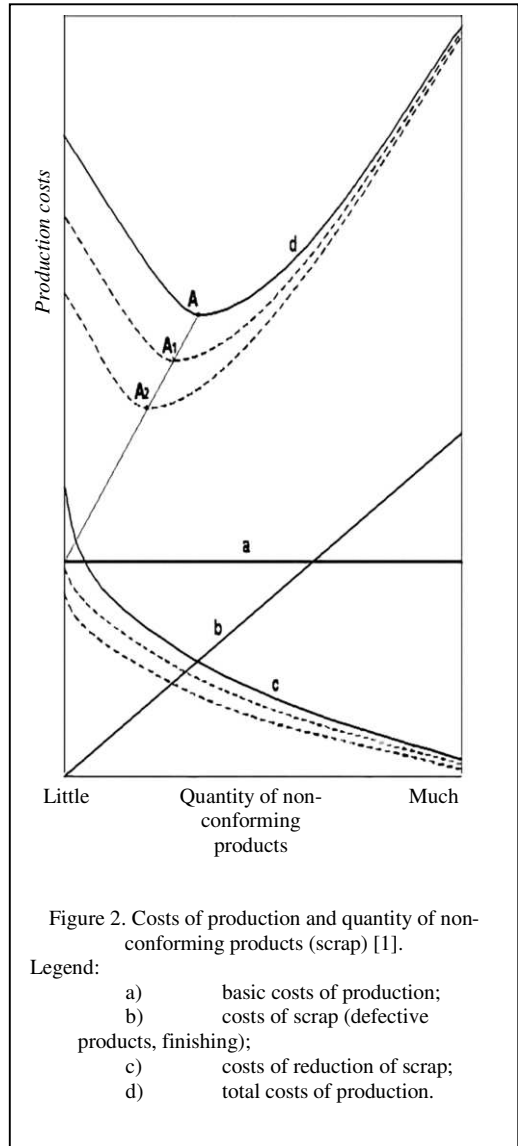

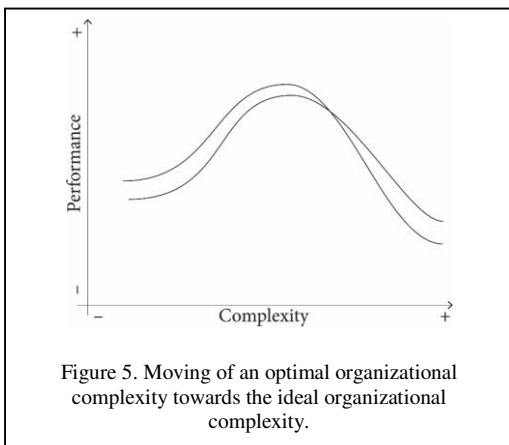
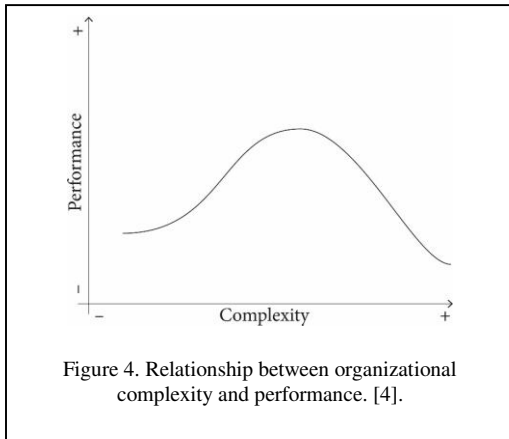

### III. RESULTS

The growing organizational complexity is a result of the adaptation of the organization during its confrontation with the complexity of the external context. In order that the organization operates successfully, it is necessary to have a certain level of organizational complexity. However, this growth of complexity is desirable as long as it creates the value for the organization, which is verified by evaluation of the performance.

The graphic representations (Figs. 2 and 4) show that there is an optimal percentage of scrap for which total costs of production are minimal. The level of complexity that enables the realization of this “optimum” can be considered “an optimal organizational complexity”.

By improving the organizational complexity, the curve (Fig.4) will move to the left in the

direction of reducing complexity and achieving positive performance quality (Fig.5). This moving continues as long as the appropriate level of organizational complexity creates value.

By including more (new) PDCA cycles, performance evaluation and full creativity, we can expect that over time the moving of an optimal organizational complexity, which is directly related to the complexity of the external context (e.g. customer satisfaction), will correspond to positive performance quality and the ideal goal. I named this level of organizational complexity an *ideal (final)*.

### IV. CONCLUSION

Reaching the minimum percentage of scrap (quantity of non-conforming products and finishing) for which the costs of production are minimal does not imply a competitive advantage on the market. The reason for this lies in a fact that other manufacturers can find a more efficient way to reduce both the costs of production and the quantity of scrap at the same time. An organization can achieve a competitive advantage if it constantly strives to reach an ideal goal that corresponds with positive performance quality and ideal organizational complexity.

For the dominant majority of management theorists and practitioners, the ideal goal and ideal organizational complexity is the utopia. However, these assumptions have not been disproved to date. Therefore, it represents a great challenge for the future efforts of creative, motivated and persistent people to either confirm or reject these assumptions.

### REFERENCES

- [1] Kondo, J. (1997). Motivation, creativity and quality control: a Japanese perspective. ECPD, Beograd. (pp. 57-69).
- [2] Schwandt, A. (2009). Measuring organizational complexity and its impact on organizational performance—A comprehensive conceptual model and empirical study. Technische Universität Berlin, Fakultät VII-Wirtschaft und Management: Technische Universität Berlin.
- [3] Šarović, D., & Perović, J.M. (2022). Complexity of the Concept of the Sustainability of Sustainable Success. In X International Conference “Quality System Condition for Successful Business and Competitiveness”, Proceedings, Association for Quality and Standardization of Serbia, Kopaonik.

# Digital Transformation of the Teaching Process using Mobile Devices and Dedicated Software

Momčilo B. Randelović<sup>1</sup>, Radoje B. Jevtić<sup>2</sup>, Ivana D. Janković<sup>3</sup>

<sup>1</sup>University Business Academy in Novi Sad, Faculty of Social Sciences Belgrade, Serbia

<sup>2,3</sup>School for Electrical Engineering “Nikola Tesla”, Niš, Serbia

<sup>1</sup>momcilo.randjelovic@fdn.edu.rs, <sup>2</sup>jevta@etstesla.ni.ac.rs, <sup>3</sup>ivana.etstesla@gmail.com

**Abstract**—Digital transformation, as an ongoing global process, has affected all business segments in the world, including educational systems. With the application of information technologies, direct teaching in the classroom has been enriched with multimedia elements, various applications for presenting teaching content, but they have not significantly contributed to greater interaction between teachers and students in class. This paper presents commercial software tools for that purpose, as well as specialized applications. They are classified according to the pedagogical requirements for digital dialogue in the classroom. The results showed that each of the tested applications can be used relatively successfully, but for the realization of a real digital dialogue in the classroom and the realization of a functional digital transformation, it is still necessary to develop a comprehensive, specialized information system.

**Keywords** - digital dialogue, digital transformation, programming, Java, mobile devices.

## I. INTRODUCTION

The term digital transformation primarily refers to the adoption of disruptive technologies in order to increase productivity and create new values. Most business entities, industrial companies, banks, trade, transport, etc. have largely changed their work environment, integrating digital technology and business activities into a new business model. The digital transformation itself represents a kind of process of integration of digital technologies, literally in all areas of business, with radical changes in the way technology and people are used with the aim

of improving their own performance, in accordance with new market requirements [1].

Digital transformation in education, using digital technologies in teaching, should improve the effectiveness of learning. The use of information and communication technologies (ICT) in education has led to the development of numerous distance learning systems (*Distance Learning System*, DLS), as well as complex modern systems for systematic learning management (*Learning Management System*, LMS). Such systems, which contain software applications for administration, documentation, testing, monitoring, reporting and delivery of electronic educational materials, are united under the name of electronic learning (*e-learning*) [2].

Although LMS are a massive trend in the world, practice has shown that due to the imperfection in communication between students and teachers within LMS, traditional teaching still retains a significant place in educational processes [3]. Information technology products as modern digital learning tools are modern to the extent that the needs of the users require them and the capabilities of the teachers enable them [4]. On the other hand, despite the obvious influence on all segments of the educational system, IT did not suppress, or even significantly transform, direct teaching. With the application of information technologies, direct teaching in the classroom has been enriched with multimedia elements, various applications for presenting teaching content, but they have not contributed much to greater interaction between teachers and students during the lesson itself [5]. A variety of techniques and

methods of electronic testing and surveying of students are available, but mostly after lectures, in different, specially designated times [6].

Among the activities of teaching subjects, what stands out is what conditions every teaching process, which is the organization of students' work in class. By placing students at the center of learning, new demands arise for both students and teachers. Students must be as clear as possible about their interests, their possibilities and needs. They must also be able to communicate with each other, with their teachers and advisors. They must be self-directed towards learning, i.e. they can organize their own learning process relatively independently, and on the other hand they can ask for the help of teachers, superiors or experts when necessary and be able to monitor their progress [7]. To this end, teachers should be involved in ongoing assessment to better understand the peculiarities of each student, their needs and monitor their progress, to provide them with resources and guidelines, adequate to their interests, which should involve them in projects, as well as to meet the requirements of the curricula. I can get most of that information first of all from the students themselves, parents, educators. Obviously, a constant active dialogue of all teaching subjects is necessary. Technology can help students and teachers meet these demands.

This paper discusses several popular commercial applications intended for digital interaction in the classroom. In the first part, selected commercial software solutions are presented, with their most significant features: *Socrative*, *Edmodo*, *Quizizz* and *Kahoot*. The second part of this paper describes the original software package of specially developed programs for digital dialogue: *Information System for Digital Dialogue in the Classroom* (SDDC). The development environment, used technologies, client and server side and basic communication flows are described. The third part of this paper contains the results of testing in practice of each of the mentioned applications. The fourth part summarizes the results, experiences and comments.

## II. APPLICATIONS FOR DIGITAL INTERACTION BETWEEN TEACHERS AND STUDENTS

As a starting point in this research, we used previous results of examining the characteristics of different student response systems [8]. There

are a number of models and techniques of cooperative learning, which differ from each other:

- in terms of how students work together,
- in terms of learning tasks,
- regarding the degree of cooperation between students,
- in terms of creating a competitive atmosphere in the classroom.

Some elements of the structure of the conditions are always represented, regardless of which variant of the teaching work it is about. Digital systems for student responses (*Classroom Response Systems*) - CRS, in this case represent an adequate solution. Namely, the use of CRS has been practiced at universities and schools all over the world for two decades, so they are already a proven didactic tool.

CRS are also called classroom response technologies, voting systems, clickers, or student response systems based on the BYOD (*Bring Your Own Device*) concept. They consist of individual remote controls that students use to answer questions and a wireless transceiver on the teacher's server that collects student data. Other classroom technologies are online, and students can use cell phones or other personal mobile devices to answer questions. With this technology, instructors can design multiple-choice questions for students, and students can answer anonymously or log in using a personal mobile device. In addition to multiple-choice questions, some web-based classroom response software, such as *Poll Everywhere*, allow questions that require text responses, and application *Learning Catalytics* allows even more question types, such as those that require text, sketch, and math type the answers, expressions. CRS contains 4 temporally and functionally divided segments that change periodically during the lesson:

- segment of the introductory presentation,
- dialogue segment,
- assessment segment,
- segment of the closing presentation.

There are multiple solutions for user software. Depending on the needs of the user (school, faculty) and the type of teaching process, the following are used:

- general commercial software - software of a wider range of application that is more or less usable in different institutions (*Interwrite Response, MS Interactive Classroom, ...*);
- dedicated user software – a specialized program package, ordered and created according to the specifics and special requirements of the user;
- free Web 2.0 solutions - simple programs that can be downloaded from the Internet and usually meet the needs of only a part of the requirements. They are suitable for the first phase of the introduction of digital dialogue - the testing and testing phase, until the final requirements are precisely defined (*TopHatMonocle, SMSPoll, mQlicker, ClickerSchool, PollEverywhere, FreeMobilePolls, ...*);
- special solutions for communication within the existing LMS that is already used in classes, as an extension or addition to the existing software (if the applied LMS has them).

The communication system for connecting the student's device with the lecturer's computer can be based on different technologies: infrared (IR), radio-frequency (RF), SMS, Wi-Fi, LAN. It is only necessary to ensure simultaneous acceptance of a large number of responses from students' mobile devices (PRD - *Personal Response Device*) (Fig.1) [8].

The programs *Socrative*, *Edmodo*, *Quizizz* and *Kahoot* were tested. Later tests, in practice, confirmed the test results. Unlike previous research, this paper also includes an examination of the application's ability to be used in the digital transformation process. Therefore, special attention is paid to the possibilities of automatic digitization and archiving of key activities during classes, atomization of data and the possibility of using saved data in other applications (Fig.2).

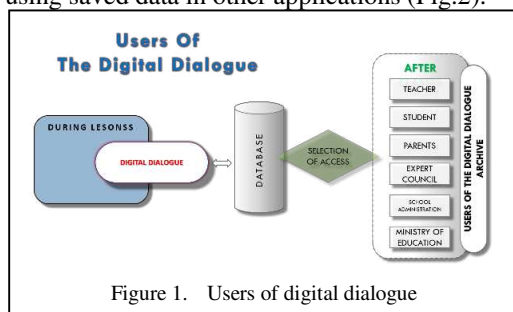

Figure 1. Users of digital dialogue

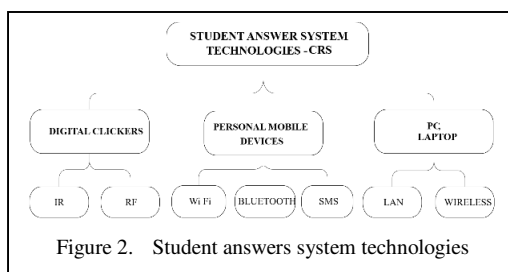

Figure 2. Student answers system technologies

**Socrative** is a web platform designed to provide reliable digital communication between students and teachers. It offers a system of learning through questions and answers that teachers prepare before class. It represents another attempt to implement online testing, distance learning and paperless learning. Evaluation is almost instant and functional in practice. Socrative is a partially free tool that allows for two types of questions:

- multiple choice,
- short answer.

It is possible to change the order of questions, delete and add questions, generate a random order of questions and answers. The special advantage of this tool is that students do not have to log in to the system with their e-mail address, but only type the code of the classroom (room) that they receive from the teacher. It is possible for a quiz that has already been created to be recorded, copied and saved in the modified cloud under a different name. Socrative also provides a SOC code for sharing quizzes. Initiating questions can be realized in two ways: students answer each question successively in their own rhythm (*Student Passed Quiz* - which is mostly not practiced in digital dialogue) and the teacher who initiates the question determines the time for providing the answer - *Teacher Passed Quiz*. After each answer, the students wait for a new question, which is also initiated by the teacher. At the end of the class, all questions and all answers can be discussed and recorded in an *Excel* file and sent to the teacher by email.

**Kahoot** is an application that can be used to create interactive quizzes in the classroom. When creating an account, it is necessary for the teacher to report his position in education and the exact name of the institution to which he belongs, in addition to his e-mail address. Students are also expected to log in with their email address and even their date of birth. There is the possibility of creating flash questions or forming a whole quiz. A quiz, survey or discussion can be created as

types of questionnaires, although in fact they differ only according to the number of answers offered and the way they are collected. The perceived shortcoming during testing refers to the inability of students to see the questions and alternative answers on their mobile phones, instead they are directed to an image from a projector or white board. As with the *Socratic* application, reports are also generated in the form of an *Excel* file. Specificity represents the possibility for the student to evaluate the quiz at the end of the lesson and recommend it to friends.

*Quizizz* is a software tool very similar to the described *Kahoot* program. Students log in using a pin number or a code (*Game Code*) that they enter on the *join.quizizz.com* page. After that, they enter their name, enter the game and automatically get their avatar. The use of avatars contributes to the visual attractiveness of the quiz, but also indicates that it is intended for students of lower grades. The teacher starts the quiz by clicking *Play*. As with the previous programs, the teacher's and student's screens are different - the teacher first instructs the students to start answering the questions on the screen until the first answers start to arrive. After that, the teacher monitors who answers, whether the answers are correct and which question the student is on. Therefore, the questions are not displayed on the teacher's computer, because not all students have to answer the same questions at the same time. However, for the needs of digital dialogue in the classroom, it is necessary that all questions - all students answer at the same time, especially since the questions are asked asynchronously results in an *Excel* table.

*Edmodo* is a web tool for the realization of a digital system for student answers. This internet application first of all gained popularity as a service for professional connection of teachers - a social network of educators. However, some segments of the application can be used very successfully as a platform for learning, testing and realizing digital dialogue in the classroom. Use requires full teacher registration, joining an existing community or group. This is also expected from the students, however, their full control is provided by the teacher. Without teacher supervision, students cannot communicate with anyone outside the group, or even with each other. Student profiles are private, and teachers and parents can view them. Work with students begins with the teacher forming a study group and inviting the students of the class he teaches to it, by sending them the

code they need to log in. To set a task, the recruiter can use the option of the same name, which allows him to specify the name of the task and attach a description. The defined task becomes available to the students when the teacher places it on the profile wall, then the students add comments and solutions to the task (which only the teacher can open). For each question asked, statistics are created on how many students answered correctly and how many answered incorrectly in order to see which content they understand less well or where the questions were asked unclearly. Practice has shown that the dynamics of asking questions and receiving answers is the weaker side of this application, so fewer questions can be asked during the lesson.

### III. DEVELOPMENT OF DEDICATED SOFTWARE FOR DIGITAL DIALOGUE – SYSTEM FOR DIGITAL DIALOGUE IN THE CLASSROOM (SDDC)

The information system for the implementation of digital dialogue in the classroom should ensure the connection of all subjects of the teaching process, via the Internet and wireless networks. The system for connecting students' devices with the teacher's computer can be based on different technologies: infrared (IR), radio-frequency (RF), SMS, Wi-Fi, and LAN. It is necessary to ensure that the broadcast of a large number of responses from students' mobile devices - PRS (*Personal Response System*) in real time is accepted at the same time [8].

The server application accepts client requests and processes them through its interface. The entire system functions using web service technology (Fig.3). The application is three-tiered. The upper layer consists of a Windows-form client application for teachers and a web (*Android*) application for students. These two client applications provide an interface through

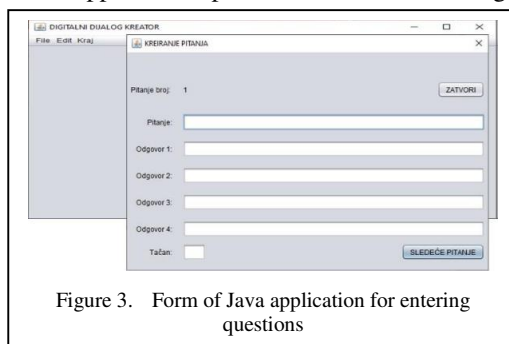

Figure 3. Form of Java application for entering questions



which data is forwarded to the components. On the middle layer are the components, which enable communication with the database, perform all operations on databases and pass data between layers. They contain most of the system's logic. The bottom layer is the data layer. Applications that make up SDDC can be divided into client and server applications [9].

### A. Java Applications on the Server

The server application was implemented in the *Eclipse EE (Java Enterprise Edition)* IDE 4.24.0 environment in the Java programming language (java.version-17.0.3).

Such an environment already has built-in functionality for handling REST services, which means that there is no need to use an external one or create your own. All persistent data is stored in *MySQL* database. This approach enables the installation of the entire system within a school or college at the local level by creating a desktop application. Of course, the principle is the same in the case of setting up a web application on the server side (Fig.3).

The desktop *Windows* application is intended for administrators and teachers. It allows viewing and updating data on system users, both students and other teachers, tasks and tests, viewing statistical data on the use of the application and setting the parameters necessary for the correct operation of the application.

The application itself on the server is composed of two basic modules:

- *Creator* – a module that contains forms for entering data about students, classes and groups, for creating questions with answers, for grouping questions according to teaching units and forms for creating tests.
- *StartDialog* – a module that contains forms for selecting a group of questions or a test and the process of activating the digital dialog itself.

All data in this application is filled in by the teacher. If he knows the curriculum and students well, the teacher can enter most of the data at the beginning of the school year (Fig.4).

A set of 5-10 standard questions is formed for each class of processing new material. Tests are created for refresher classes (Fig.5).

The *Creator* module in the desktop application does not require a web connection, but a *MySQL* database connection is required.

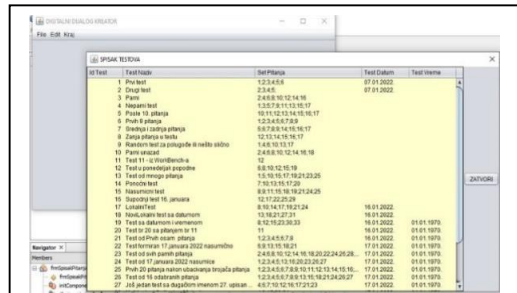

Figure 4. Form of Java application for creating a group of questions in a teaching unit

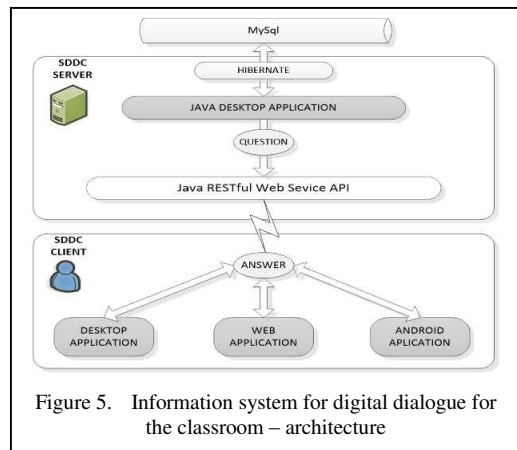

Figure 5. Information system for digital dialogue for the classroom – architecture

The *StartDialog* module requires a mandatory web connection and a *MySQL* database connection.

### B. Java Client-Side Android Application

On the client side in the digital dialog is an application whose most important role is to provide the user with a display of questions and the possibility of the simplest possible answer. Since the speed of response factor is also significant, they are most often implemented through the form of *Multiple Choice Questions* (Fig.6). Unlike the *Java* application on the server, which is entirely developed in *Eclipse* IDE, the client application is implemented in the *Android Studio Arctic Fox* development environment based on REST services [9]. Each client application functions independently, while on the server, after logging in, a new program thread is created for each individual user.



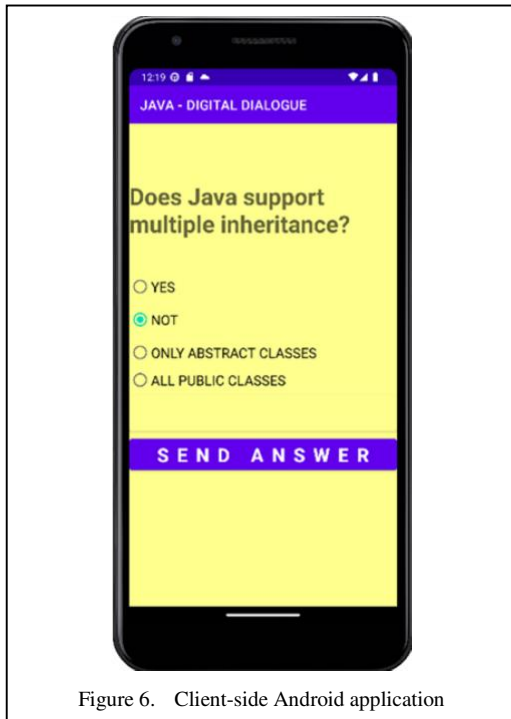

Figure 6. Client-side Android application

#### IV. RESULTS OF TESTING THE POSSIBILITIES OF THE DESCRIBED APPLICATIONS

The table (Table I) shows the summarized results of the conducted research for all five programs. The research focused on the most important features that an information system for digital dialogue in the classroom should have. These are, first of all, communication properties, the speed of accepting and processing client responses, as well as saving data in relational databases. Also, in order to achieve the digital transformation of the teaching process, it is necessary that the software used provides systematically unified and digitized key activities of both teachers and students during lectures. All these features of the software are defined in thirteen points and each of the tested applications received a score for each of these points.

Based on the test results, we can see that none of the tested applications meets all 13 conditions. Also, any of the tested applications can be used as part of CRS in the process of digital dialogue, only a purpose-built *Java* application (SDDC) fully meets the requirements of digital transformation.

Out of 13 tested conditions, SDDC fulfills 12. The only question: “Unlimited number of correct answers” did not receive a positive answer, but

TABLE I. REQUIREMENTS FOR DIGITAL DIALOGUE

SOFTWARE CAPABILITIES FOR DIGITAL DIALOGUE IN EDUCATION	Socrative	Edmodo	Quizizz	Kahoot	SDDC
1. Questions with suggested answers	*	*	*	*	*
2. Unlimited number of correct answers	*		*		
3. The possibility of inserting images into the question	*	*	*	*	*
4. Time limit for solving tasks	*	*	*	*	*
5. The teacher controls the time	*				*
6. The possibility of changing the order of questions	*	*	*		*
7. Ability to change the order of answers	*	*	*		*
8. Saving total results	*		*		*
9. Writing reports in an Excel table	*	*	*	*	*
10. Writing reports to the database					*
11. The possibility of repeating the question after the explanation					*
12. Graphical presentation of results in real time					*
13. Recording elapsed time for response					*

for the purposes of digital dialogue it is not of key importance. According to the table, right behind him, in second place is Socrative, which fulfills 9 conditions.

#### V. CONCLUSION

As the digital dialogue unequivocally represents a complete redesign of the teaching process, in order to improve the most important properties, its application is rightly expected to significantly raise the level of efficiency of direct teaching. From the aspect of digital transformation, the use of mobile devices, according to the BYOD concept, with the support of purpose-designed applications for digital dialogue, represents a fundamental change in the way of thinking, organizing, implementing and analyzing activities in immediate teaching and not just a mere technological innovation. Key information, generated during the lecture, which is digitized and stored in the database with this procedure, can later be analyzed and cross-referenced with other data related to the activities

of teachers, students, parents, professional councils and other subjects. In this sense, the application of mobile devices and special software, through the concept of digital dialogue, in the most obvious way, provides strong support for the general paradigm of digital transformation of educational processes.

#### REFERENCES

- [1] Ebert, C., & Henrique C. Duarte, C. (2018). Digital Transformation. *IEEE Software*, 35(4), 16-21.
- [2] Cavus, N. (2015). Distance Learning And Learning Management Systems. *Procedia - Social and Behavioral Sciences*, 191, 872-877.
- [3] Atiyah, J., El Sherbiny, M. M., & Guirguis, S. K. (2015). Evaluation of E-Learning Program versus Traditional Education Instruction for Undergraduate. *International Journal of Advanced Research in Science, Engineering and Technology*, 2(7), 776-786.
- [4] Randelović, M., & Veljović, A. (2017). Reinženjering neposredne nastave u hibridnom sistemu učenja. *Nacionalna konferencija sa međunarodnim učešćem - Reinženjering poslovnih procesa u obrazovanju RPPO17*, Čačak (pp. 1-21).
- [5] Aslan, S. (2010). What are the factors that contribute to ineffective and limited use of Learning Management Systems in the Schools?. *The Annual Convention of the Association for Educational Communications and Technology*, Anaheim, CA, 2, (pp. 1-4).
- [6] Jamornmann, U. (2004). Techniques for Assessing Students' eLearning Achievement. *International Journal of The Computer, the Internet and Management*, 12(2), 26 -31.
- [7] Moeller, B., & Reitzes, T. (2011). *Integrating technology with student-centered learning*. Quincy: Nellie Mae Education Foundation (NMEF).
- [8] Randelović, M., & Veljović, A. (2018). Sistemi za odgovore učenika u hibridnom učenju. *Nacionalna konferencija sa međunarodnim učešćem - ITOP18*. 3, Čačak. Fakultet tehničkih nauka u Čačku.
- [9] Randelović, M., Papić, M., Veljović, V., & Stanojević, L. (2022). Development of information system for digital dialogue in teaching using RESTful service. *9th International scientific conference Technics and informatics in education* (pp. 49-55). University of Kragujevac, Faculty of Technical Sciences Čačak, Serbia.
- [10] Ei Ei Thu and Than Nwe Aung. (2015). Developing Mobile Application Framework by Using RESTful Web Service with JSON Parser. In *International Conference on Genetic and Evolutionary Computing*, Mandalay, Myanmar, (pp. 177–184). University of Computer Studies Mandalay (UCSM).



# The Importance of the Evaluation of Investment Projects in Local Government Units

Dragan Dokić<sup>1</sup>, Vesna Gantner<sup>2</sup>

<sup>1</sup>Erdut Municipality, Dalj, Croatia

<sup>2</sup>Josip Juraj Strossmayer University of Osijek, Faculty of Agrobiotechnical Sciences  
Osijek, Osijek, Croatia

<sup>1</sup>dragan.dokic79@gmail.com, <sup>2</sup>vgantner@fazos.hr

**Abstract**—The aim of this paper was to point out the importance of learning about investment projects in LGUs through a theoretical approach using a range of methods for evaluating projects. The choice of realization of the investment project should be accompanied to a large extent by the benefit that the project has for the social community. In the paper, through theoretical analysis, the methods for evaluating investment projects will be considered, considering the necessary variables that affect the justification of the investment. Based on the considered methodology, the paper will discuss methods and calculations based on which the clearest knowledge about the justification of choosing a project investment is obtained.

**Keywords** - investment projects, methods for evaluation of investment projects, social benefit, local self-government units

## I. INTRODUCTION

The general term investment evaluation refers to a set of actions aimed at determining the justification and acceptability of the investment [1]. In the operational sense, evaluation could be defined as the phase of investment project planning in which the following activities take place [2]:

- defining the development goals within which the investment is planned;
- defining criteria and choosing methods for investment evaluation;

- creating a documentation and information base for the application of evaluation methods;
- application of criteria and methods;
- making an investment decision (positive or negative).

Considering to the effects it produces, the investment project can be observed and evaluated from the perspective of the local self-government in which the investment is made and from the perspective of the wider social community or society. Therefore, the consideration of the effects of the investment project and the use of appropriate evaluation criteria are different [3], depending on which aspect is involved. The role of LGUs in national economies has changed significantly in modern times as a result of globalization and structural adjustments. Understanding these changes is important for creating an efficient investment concept at the local level aimed at local development programming. Municipalities are basic socioeconomic, political and administrative units, responsible for the development of the local economy and social services in their territories. The functioning of LGUs is an essential issue for their existence and sustainability. Depending on the legislative framework, LGUs operate according to the territorial principle within which they perform their work in accordance with the applicable regulations. Each LGU contributes to building

its own competitiveness with individual strategic documents. In general, LGUs regulate:

- development of settlements and housing, spatial and urban planning;
- communal policy and management;
- economic policy;
- social policy and basic education;
- culture and sports;
- consumer protection;
- environmental protection;
- fire and civil protection, and
- traffic connections.

Thus, for LGUs, the most significant is the immediate economic effects that contribute to the increase in budget revenues, while for society as a whole, in addition to the economic effects, the most important so-called non-economic and indirect effects from investments.

Investments in LGUs should be observed and evaluated from a broader social aspect, which indicates the division of the investment project into two parts [5]:

- assessment of the financial and market effects of the investment (financial analysis);
- evaluation of the socio-economic effects of the investment (economic analysis).

TABLE I. CRITERIA FOR SELECTING INVESTMENT PROJECTS [4].

Evaluation elements	Financial-market effects	Social-economic effects
Criterion for evaluating the effects of the investment	Effect of investment on profit	The effect of the investment on all the goals of socio-economic development
Comprehensiveness of investment effects	Immediate effects of the investment	Direct and indirect effects of the investment
Prices for evaluating the effects of the investment	Market prices of investment inputs and outputs	Correcting input and output prices
Time preferences of investment decision makers	Individual time preferences	Social time preferences

In the assessment of financial-market effects, a part of the newly realized value of the project that will be created and left in the JLS is estimated, and the inputs and outputs of the project are valued according to market prices [6]. When evaluating the socioeconomic effects, the analysis includes the effects of the project on all the goals of socio-economic development, namely the direct effects in the investment itself, but also the indirect effects that will appear outside of it. In addition, all effects as well as investment and exploitation costs are valued according to corrected prices that reflect their value from the perspective of society. According to Bendeković, this means that customs duties, taxes, subsidies, etc. should be excluded from the prices since the mentioned costs mean a spillover of income from the economy to the benefit of the social community.

## II. MATERIALS AND METHODS

Evaluation of investments is carried out to gain knowledge about their justification and profitability and is carried out in the pre-investment stages. The most well-known internationally recognized methodologies for evaluating investment projects are the methodology of the International Bank for Reconstruction and Development, the UNIDO methodology and Cost-Benefit Analysis (CBA).

Investment projects financed by the International Bank for Reconstruction and Development can be realized following the rules and procedures required by this bank, to use the approved loan for the approved investment project. Investment projects go through several stages in the evaluation process before the loan is approved and realized, and in each stage, this bank plays an active role in a certain way. These are the following stages [1]:

- strategy and identification;
- project preparation;
- project assessment;
- project approval;
- implementation or realization of the project;
- end of a project;
- project evaluation.

UNIDO (United Nations Industrial Development Organization) methodology is

used to assess the profitability of investment projects in the following segments [2]:

- financial analysis;
- analysis of national profitability; and
- assessment in conditions of uncertainty.

CBA (Cost-benefit analysis) is a project evaluation technique and was developed as a response to the shortcomings of financial analysis of investment projects. CBA provides an assessment of socio-economic impacts on the investment itself. Compared to standard financial analysis, CBA also includes a social dimension in which society is a de facto investor. In a broader sense, CBA includes [8]:

- a description of project solutions that solve the set goals of the project;
- socio-economic context;
- institutional analysis;
- creditworthiness analysis;
- demand analysis;
- technical-structural analysis;
- financial analysis;
- economic analysis;
- sensitivity and risk analysis.

The most common evaluations of investment projects imply the omission of cash flows (discount cash flow - DCF), that is, all those calculations that do not consider opportunity costs - benefits based on an investment in an investment [9]:

- The annual profit method is a method that is determined for each year or only for typical years in the case of a long-term investment. The calculation elements that are used are income and expenses increased by profit tax taken from the income statement of the specific year according to the formula:

$$\text{profit or loss} = \text{income} - (\text{expenses} + \text{tax}) . \quad (1)$$

- The payback period is defined as the period required to return the original investment through net cash flow. This method is used for smaller investments

that involve rehabilitation or reconstruction of the existing condition.

This method includes calculations [10]:

$$\begin{aligned} \text{average rate of return} &= \\ &= \frac{\text{accounting earnings in period } t}{\text{initial investment}} \cdot 100 , \quad (2) \end{aligned}$$

$$\begin{aligned} \text{payback period} &= \\ &= \frac{\text{initial investment}}{\text{annual receipts from the project}} , \quad (3) \end{aligned}$$

$$\text{internal rate of return} = \left[ \frac{A_t}{(1+r)^t} \right] = 0 , \quad (4)$$

where:

$A_t$  - cash flow for period  $t$ ,

$r$  – the discount rate that equates the present value of expected expenditures with the present value of expected receipts.

$$\text{net present value} = \frac{A_t}{(1+k)^t} , \quad (5)$$

$k$  – required rate of return,

$$\text{profitability index} = \frac{A_t}{A_0} , \quad (6)$$

$A_0$  – Initial investment.

- The method of internal rate of profitability (IRP) is a discounted rate at which the present value of the expected future cash inflow is equal to the present value of expenses. It represents the rate at which the present value of the inflow is equal to the present value of invested capital, that is, the net present value is equal to zero [11]. Calculation formula:

$$\begin{aligned} IRP &= A_0 + \frac{A_1}{(1+IRR)^1} + \\ &+ \frac{A_2}{(1+IRR)^2} + \frac{A_t}{(1+IRR)^t} , \quad (7) \end{aligned}$$

*IRP* – internal rate of profitability,

*IRR* – internal rate of return.

- The benefit-cost ratio method is used when making strategic decisions for an investment in a project whose economic profitability is not easy to evaluate using standard conventional methods. Cost-benefit analysis helps to calculate returns on investments based on the costs, resources and risks involved in that investment [12]. It is a process by which companies can analyse decisions, systems or projects or determine value for intangible assets. It is calculated by the formula:

$$B_c = \sum_{t=1}^n \frac{P_t}{\left(1 + \frac{p}{100}\right)^t} \Bigg/ \sum_{t=1}^n \frac{T_t}{\left(1 + \frac{p}{100}\right)^t} + 1, \quad (8)$$

where:

$B_c$  - benefit and cost ratio,

$P_t$  - income in year  $t$ ,

$T_t$  - costs in year  $t$ ,

$I$  - investment costs,

$n$  - duration of the project,

$p$  - required interest rate.

- the annuity method is a method of examining the financial efficiency of investment options by which all amounts of inflows and outflows are reduced to the average annual level via the annuity factor, which is the reciprocal of the discount factor of equal periodic amounts. According to this method, all amounts of monetary receipts and current monetary expenditures, as well as initial investment investments, are first reduced to the time when a specific investment option begins to take effect. To achieve this, the discounting technique is applied to the amounts of cash receipts and expenses, and interest is applied to the initial investments [13]. The amounts of discounted cash receipts, cash expenses and accrued initial investments are added together. The obtained sum is reduced to the average annual amount using the

annuity factor. It is calculated according to the formula:

$$a_f = \frac{r^n (r-1)}{r^n - 1}, \quad (9)$$

$$A_v = a_f \cdot \sum_{t=1}^n \frac{F_t}{\left(1 + \frac{p}{100}\right)^t}. \quad (10)$$

$a_f$  – annuity factor,

$F_t$  – net cash flow in year  $t$ ,

$A_v$  – annuity amount of net present value,

$A_i$  – annuity amount of investment costs,

$n$  – duration of the project,

$p$  – required interest rate,

$r$  – decrease interest factor  $(1+p/100)$ .

- multi-criteria analysis is a multi-criteria evaluation method that focuses on investment goals from multiple points of view, and scenarios, and assigns weight to each criterion that can be measured [14]. With this method, it is possible during the investment analysis to consider those factors that previous financial analyses did not do so. In this case, it is important to consider the effects of the investments on the goals, assign a weight to each goal and calculate the final effect.

Each investment represents a certain business risk that can be calculated with the help of various models and projections. Different indicators, such as cost-benefit analysis, such as internal rate of return, net present value, benefit-cost ratio, etc., can lead to different results, so it is up to the investor to evaluate which methods he has more confidence in, that is, which analysis provides him more information. From the point of view of LGUs, investment evaluation methods used to determine the effects of investments in LGUs must also satisfy the social benefit.

### III. RESULTS AND DISCUSSION

In the previous part of the work, the focus of the research was methodology and calculations that can be used in the evaluation of investment projects. When choosing a project idea,

decision-makers should be able to read and interpret the obtained results, that is, understand well what the individual indicators represent. The correct interpretation of the results is very important in order to choose the project that provides the most benefits to the social community. When choosing a project, those responsible in LGUs must consider the profitability of the project, but the impact on decision-making also has a social benefit. Furthermore, those responsible in LGUs must consider the connection between project investments. It is necessary to build on previous investments with new investments in order to create a system that is self-sustaining. The correlation calculation between projects should show a result greater than 1.00, which means that there is a significant relationship between project investments.

*Annual profit method* – The value obtained by the calculation should be inviting, which can be explained by the fact that revenues are greater than expenses, that is, that a positive result or profit is achieved. The variables that are put into the relationship are taken from the income statement, all income during the time period of the investment as well as all expenses during the same period. Furthermore, the total income is then taxed at the applicable tax rate and the resulting value is added to the total expenses. If the difference is a positive number, the project is profitable. Otherwise, if obtained value is a negative number, the project is unprofitable. This method considers only bookkeeping quantities, and does not consider other social aspects, does not consider the flow of money over a certain period of time, which represents its shortcomings, but also the reason for the creation of other methods.

*The return period* includes the following methods:

*The average rate of return* - It is expressed as a fraction when accounting earnings in a certain period are compared to the value of the initial investment. The obtained result is multiplied by 100. The result shows the average percentage of investment return. If the percentage amount is higher, the investment will be returned sooner.

The main disadvantages of this method are that it ignores the cash flow after the return of the original deposit, and like the previous method, it ignores the calculation of the value of money over time.

*Payback period* - It is expressed as a fraction when the initial investment and annual receipts are put in relation. The obtained result represents the investment return time period. If the payback period is less than an acceptable maximum specified period, the investment proposal is accepted, while otherwise, if the payback period is longer, the investment is rejected. This method is most often used as a supplement to other methods. The shorter the payback period, the lower the risk of the project and the higher its liquidity. It is very important for LGUs to burden their budget with debt repayment as soon as possible.

*Internal rate of return* – This method results in a value that is discounted to the present value. It considers the relationship of cash flow in a certain period of time and the discount rate that must equate the value of expected expenses with the present value of expected receipts. The criterion on the basis of which the project is accepted or rejected is the comparison of the internal rate of return with the requested (marginal or minimum) rate of return. If the obtained result is higher than the requested rate, the project is accepted, and if the value is lower, the project is rejected. The main disadvantage of this method is that it makes it impossible to determine the real profitability of the investment. Before assessing the results of the investment, it is necessary to define what is profit, what is depreciation, and what is invested capital, according to the different legislation of a particular country.

*Net present value* - can be treated as a representative evaluation method, and other methods can be said to be inferior to the NSV method [13]. This method shows the difference between invested capital and the total discounted difference between the inflow and outflow of funds throughout the entire duration of the investment project. The discount rate is determined earlier. Net present value is calculated by summing all discounted net benefits. Net amounts can also be negative, which indicates a loss. Net profit is the amount that remains after all expenses have been deducted from all receipts in a given year. In practice, it is also called “pure cash flow”. If the net present value is positive, that is, the discounted value of the cash inflow is greater than the invested capital, it means that the profitability of the investment is greater than the minimum required and the investment can be accepted. A negative net present value means



that the investment is not profitable. The disadvantages of this method are that it does not show the real profitability of the project, and therefore it is often supplemented with other methods.

*Profitability index* - represents the ratio of benefits and costs of the project, it is the relationship between the present value of future cash flows and the average cost [13]. The calculated value must be greater than 1.00, which indicates that the investment project is acceptable. If the result is less than 1.00, the project should be rejected. When calculating, the net index is calculated, not the aggregate index. The net index is calculated for the purpose of understanding the difference between the initial expenditure and the final monetary expenditure. The main disadvantage of this method is that it expresses quantities in relative amounts.

*The method of the internal rate of return on capital* is a discounted rate at which the present value of the expected future cash inflow is equal to the present value of expenses. It represents the rate at which the present value of the inflow is equal to the present value of invested capital, that is, the net present value is equal to zero. The advantage of this method is that it shows the real profitability of the investment and in this sense, the result is understandable and clear. the value of the internal rate of return may change during the investment. [14]. Investors expect higher profits in the initial stages to compensate for higher risk, and lower profits in later years when conditions are known and risk is lower. This is the reason why it is not always correct to apply a single rate of return.

*Benefit-cost ratio method* - The benefit-cost ratio is the ratio of the present value of receipts to the present value of project costs plus investment costs. Supplements the profitability index. Between projects with equal or similar profitability indexes, it chooses those with lower current and investment expenses, that is, less capital-intensive projects. The threshold of acceptance of a project is when the benefit-cost ratio is greater than 1.00.

*The annuity method* is a method of examining the financial efficiency of investment options by which all amounts of inflows and outflows are reduced to the average annual level via the annuity factor, which is the reciprocal of the discount factor of equal periodic amounts. According to this method, all amounts of

monetary receipts and current monetary expenditures, as well as initial investment investments, are first reduced to the time of the beginning of the effects of a certain investment option through discounting. The amounts of discounted cash receipts, cash expenses and accrued initial investments are added together. The obtained sum is reduced to the average annual amount using the annuity factor. The annuity amount of net cash costs must be greater than the annuity amount of investment costs.

*Multi-criteria analysis* is one of the methods where the results are expressed quantitatively and qualitatively. It is important to note that the results are completely comparable and through the mentioned procedure it is possible to decide which scenario is the most acceptable for realization and which scenario will benefit the LGU the most. Making decisions implies the existence of choices. For a given set of alternatives, a question naturally arises as to which alternative is the best. The main task of the analyst in the process of multi-criteria analysis is to understand the preferences of the decision maker and to adequately develop a model that represents that preference. In every model of multi-criteria decision-making, the decision-makers preference is expressed using the aggregation of function values associated with individual criteria. In addition to economic and financial analysis, this method also considers the socio-economic context. The selection of a suitable optimization method is in itself a multi-criteria model that depends on the type of problem under consideration, the knowledge and experience of the decision-maker in the field of multi-criteria analysis, as well as the technical issues that are considered.

#### IV. CONCLUSION

From the results in the paper, it can be seen that the evaluation of investment projects is a complex process that includes a number of different methods and calculations. Given that the focus of the research is the methodology used to evaluate investment projects in LGUs. The results of the paper showed that it is not enough to evaluate with only one method, but it is necessary to implement a combination of methods that analyze profit, payback period, profitability, cost-benefit ratio, presentation of net present value and multi-criteria analysis. Through the results of the mentioned methods, a comprehensive picture of the justification of the

investment can be obtained because the results are expressed quantitatively and qualitatively. However, it is necessary to take care of the connection between the projects, that is, that the investment correlates with the economic environment and is beneficial to the social community.

#### REFERENCES

- [1] Fabozzi, F., Fuss, R., & Kaiser, D. (2008). *The Handbook of Commodity Investing*. John Wiley & Sons, Inc.
- [2] DeFusco, R., McLeavey, D., Pinto, J., & Runkle, D. (2017). *Chartered Financial Analyst Program Level 1: Ethical and Professional Standards and Quantitative Methods* (pp. 623-659). Virginia, USA: CFA Institute.
- [3] Schlossberg, A., Gorelik, A., & Karier, V. (2002). *Guide to Investment Management*. Valut Inc.
- [4] Trigeorgis, L. (1996). *Real Options, Managerial Flexibility and Strategy in Resource Allocation*. MIT Press, Cambridge.
- [5] Bendeković, J. (1993). *Planiranje investicijskih projekata*. Ekonomski institut Zagreb.
- [6] Babaei S. A. B., & Jassbi, A. J. (2022). Modified simple average internal rate of return. *The Engineering Economist*, 67(2), 157-169.
- [7] Čulo, K. (2010). *Ekonomika investicionih projekata*. Sveučilište Josipa Jurja Strossmayera u Osijeku, Građevinski Fakultet Osijek.
- [8] Morris, K., & Morris, V. (2006). *Novac & Investiranje*. Korak Plus.
- [9] Dixit, K. A., & Pindyck, S. R. (1994). *Investment Under Uncertainty*. Princeton University Press.
- [10] Robison, L. J., & Barry, P. J. (2020). Accrual income statements and present value models. *Agricultural Finance Review*, 80(5), 715-731.
- [11] Bodie, Z., Kane, A., & Marcus A. (2009). *Osnovi investicija*. Data Status, Beograd.
- [12] James, C. (1993). *Financijsko upravljanje i politika*.
- [13] LeBaron, D., & Vaitilingam, R. (1999). *The Ultimate Book of Investment Quotations*. Capstone.
- [14] Shenar, A. J., & Wideman, R. M. (1997). Toward a Fundamental Differentiation between Project Types. In *PICMET 97 conference Inovation in Tehnology Mangment: The Key to Global Leadership*, Portland.



# Bankruptcy Proceeding as a Result of Fraud: Characteristics and Consequences

Zorica Jović<sup>1</sup>

<sup>1</sup>Singidunum University, Belgrade, Serbia

<sup>1</sup>zorica.jovic2007@gmail.com

**Abstract**—The aim of this work is to indicate the types of criminal acts that can lead to the initiation of bankruptcy proceedings of a business entity. The many consequences caused by criminal acts in the economy are multiple, from causing material damage to causing damage to the overall economic and economic flows and to the state itself. According to available data from the website of the Agency for Licensing Bankruptcy Administrators, the number of bankruptcy proceedings opened in the Republic of Serbia from 1995 to 01.08.2022 is 8.628, while in 2022 alone (until 01.08.2022.) 259 bankruptcy proceedings were opened and the number of active bankruptcies on day 01.08.2022 is 1,734. The average duration of bankruptcy proceedings for still active cases is 5 years, 6 months and 10 days (the average duration for the bankruptcy of social property is longer than the average duration for the bankruptcy of private property). Considering the large number of initiated and active bankruptcies over the past years, the length of the proceedings, as well as the numerous frauds, the paper presents criminal acts that can lead to the opening of bankruptcy proceedings, indicators of criminal acts as well as penal provisions for criminal acts, all for the purpose of raising awareness society about the importance of the existing problem.

**Keywords** - bankruptcy proceedings, criminal acts, penal provisions of the law, abuses, fraud.

## I. INTRODUCTION

The economic crises that occurred at the end of the 20th and the beginning of the 21st century led to a large number of bankruptcies. Socio-economic and political relations have brought numerous forms of economic crime. According to the Law on Bankruptcy of the Republic of

Serbia, the method of initiating and implementing bankruptcy of legal entities is regulated, and the same is implemented through bankruptcy or reorganization. The reasons for which the debtor ends up in an unfavorable financial situation can be different, and one of them can be the commission of criminal acts from the so-called economic crime. Criminal acts of causing bankruptcy can be particularly in the following: irrational spending of funds, disposal of assets for nothing, excessive indebtedness, taking on irrational obligations, recklessly concluding a contract with a person unable to pay, failure to timely realize claims, destruction or concealment of property, other actions that are not in accordance with conscientious business practices [1].

Insolvency is always a reason for initiating bankruptcy proceedings, even if it was caused by force majeure. The insolvency of a business entity and bringing it into the bankruptcy process can be influenced by numerous factors as well as criminal acts. The experiences of most developing countries show that there are sudden changes in the economic structure, also in times of great instability, and therefore an increase in crime. The still very noticeable consequences of the financial crisis further complicate the business environment in the Republic of Serbia [2].

One of the most frequently cited definitions of economic crime comes from Edwin Sutherland, president of the American Sociological Association, who uses the term “white collar” crime for economic crime. This author defines this phenomenon as “criminality”

that occurs in the field of business operations and points out that its basic forms are manifested in machinations related to the purchase and sale of various shares, false statements of the state and operations of certain corporations, false advertising of goods, bribing business partners and state officials for the purpose of achieving favorable business arrangements, by misappropriating funds, tax evasion, etc. [3].

## II. INITIATION OF BANKRUPTCY PROCEEDINGS

In accordance with the Law, bankruptcy proceedings are initiated at the proposal of authorized entities (debtor, creditor or liquidation administrator). The proposal initiates the initiation of bankruptcy proceedings. The bankruptcy judge is obliged to issue a decision on the initiation of the previous bankruptcy procedure, which is initiated in order to determine the reasons for the initiation of the bankruptcy procedure, within three days from the submission of the proposal for the initiation of the bankruptcy procedure.

Bankruptcy proceedings are the last chance for creditors to try to settle or partially settle their claims against a debtor who has become insolvent. The creditor should make the existence of his claim against the debtor probable by submitting a proposal for the initiation of bankruptcy proceedings through the delivery of documentation, i.e. evidence from which the existence and amount of the claim can be determined (list of documents attached to the proposal), as well as that the debtor has become insolvent. The debtor has the right to submit a proposal to initiate bankruptcy proceedings against his assets in the event of one of the bankruptcy grounds defined in Article 11 paragraph 2 of the Bankruptcy Law (permanent inability to pay, threatened inability to pay, over-indebtedness and failure to act according to the adopted reorganization plan).

The debtor is obliged to justify his proposal for initiation of bankruptcy proceedings and the necessary documents and attachments with the proposal for initiation of bankruptcy proceedings related to the financial report, documentation on the admissibility of the proposal for initiation of bankruptcy proceedings, if there is a bankruptcy reason. Possible submission of falsified documents with entered data of untrue content is sanctioned by the criminal liability of the perpetrator of that criminal offense (Article 204, ZOS) [1].

According to the authors of the book "Bankruptcy and Bankruptcy Balance Sheets" [2], there are 4 reasons why bankruptcies are opened or must be opened:

1) The first and most common is that the entity against which the bankruptcy proceedings are initiated is incapable of successful business, that is, it is unprofitable, and therefore there are no reasons to commit capital to it and permanently tie it to it.

2) Another reason is the situation in which the business entity is profitable and successful, but is financed from inadequate sources, so it has come to a situation where it is unable to meet its financial obligations to creditors due to overindebtedness. The purpose of initiating such bankruptcies is reduced to the collection of creditors' claims, so in such situations things are put in order due to the debts of the entity against which bankruptcy is being instituted. In this case, it is about solvency. According to that logic, an unprofitable company should be shut down, and a profitable and insolvent one should be saved.

3) The third reason for the introduction of bankruptcies is the fact that in such a way some or someone's interests are concealed with the aim of achieving a benefit in the bankruptcy procedure for the proposer or subjects who are interested in the process of opening and conducting the bankruptcy procedure. In such cases, speculative motives and actions that often have hidden motives are at the fore, especially if the bankruptcy proceedings result in damage to creditors or third parties.

4) The fourth reason for the introduction of bankruptcy consists in the release of excess unnecessary resources and the use of bankruptcy legislation for the purpose of the survival of the business company over which the bankruptcy is conducted.

According to the provisions of the Bankruptcy Law, bankruptcy proceedings can be carried out through bankruptcy or reorganization. Bankruptcy is the settlement of creditors from the entire assets of the bankrupt debtor.

Reorganization is carried out with the aim of satisfying creditors according to a pre-prepared plan for reorganization by redefining debtor-creditor relations, status changes of debtors or in some other way provided for in the reorganization plan. Bankruptcy and

reorganization of a business entity that is in financial difficulties is carried out on it when it is unable to pay, i.e. when insolvent. Insolvency is a permanent inability to fulfill due obligations.

### III. FRAUDULENT ACTIONS AS A CAUSE OF INITIATION OF BANKRUPTCY PROCEEDINGS

Businesses often find themselves in a situation where their bankruptcy is inevitable due to financial frauds committed through the presentation of false financial reports, which result in a drop in their market value. Bankruptcy abuses can occur before or after the initiation of bankruptcy proceedings. Bankruptcy abuses before bankruptcy proceedings are initiated are carried out by the owners and management of companies by intentionally causing bankruptcy and falsely presenting bankruptcy in order to benefit one of the parties in the proceedings. As abuses of the bankruptcy procedure, not only the activities of management and company owners calculated to harm creditors, but also the activities of creditors whose goal is to obtain benefits at the expense of the bankrupt debtor are designated [5].

In terms of bankruptcy malfeasance, that is, criminal acts by which the perpetrators bring a business entity into bankruptcy, i.e. bankruptcy, it should be emphasized that contemporary economic and criminological practice points to two basic techniques of this phenomenon, namely: the technique of planned collapse and the technique of death bleeding [3].

The technique of planned collapse - involves the illegal actions of responsible persons in newly established or taken over business entities who, with the intention of obtaining illegal property benefits for themselves or others, mislead the responsible persons in other business entities that they will pay for the goods they have taken over from them within the agreed period, although they were aware of the fact that this would not be possible, because they kept the income generated from the sale of the taken goods, usually on the "black" market below market prices, for themselves. In the described manner, the executors consciously bring their companies into a state of insolvency and threatened or actual bankruptcy.

The "death bleeding" technique - in contrast to the planned breakdown, the "death bleeding" technique is not based on misleading the supplier that their obligations based on the goods taken over will be settled within the agreed

payment period, but the business entity is brought to bankruptcy and bankruptcy through complex commodity-monetary and financial transactions in which, over a long period of time, usually by the owner or responsible persons, the property owned by the company is intentionally reduced and transferred to the founders or third parties, all with the intention of its illegal appropriation and at the same time damage to creditors through reduction future bankruptcy estates. Life juices are deliberately extracted from a business entity, it "bleeds" and eventually "dies". The execution of this technique of criminal activity is usually well planned in advance with the use of abundant documentation and numerous transactions, the main goal of which is to conceal the actual illegal intent [4].

Abuses of bankruptcy of a business are most often carried out in the form of [3]:

- Deliberately induced bankruptcy - in the Republic of Serbia, deliberately causing the bankruptcy of a company by individual owners of companies has become a mass phenomenon, because in this way they avoid obligations to the state, other business entities and employees, who most often remain not only without wages, but also without paid contributions for health and social insurance. This usually works according to the following principle: the owner overindebts the company, so due to the impossibility of paying off the obligations (debts), he transfers the property of that company (e.g. machinery, equipment, vehicles...) to his other company or to a company owned by a related party. persons, whereby the first company with all debts is left to bankruptcy. All forms of abuse of the bankruptcy of a business company, in order to avoid payment of obligations to the state, other business entities and employees, are, as a rule, related to the establishment of a business company by related parties.
- False bankruptcy - false bankruptcy, in contrast to intentionally induced bankruptcy, arises as a result of the activity of the owner and the management to create the impression that the bankruptcy conditions have been met, and that through the bankruptcy process, the payment of all

obligations is avoided through the apparent or real reduction of their assets and the apparent indebtedness of the company.

In addition to the above, there is also the possibility of simulating bankruptcy through the execution of the so-called criminal act. fake bankruptcy.

Creative financial reporting implies deliberate, premeditated manipulation of information in financial reports in order to create a false impression of the financial position and success of the company, calculated to mislead certain interest groups, primarily investors. Creative accounting practice always implies unprofessional and unethical, and often illegal application of accounting rules, which distance the displayed performance of the company from real achievements [5].

The most common consequences of the application of creative accounting in the business practice of commercial companies are: 1. bankruptcy and large business losses of the company; 2. reducing the reliability, quality, transparency and integrity of the financial reporting process; 3. violation of the integrity and impartiality of the audit profession, auditors and audit firms; 4. reduction of public credibility and trust in the accounting and auditing profession; 5. serious doubts about the effectiveness of the audit of financial statements; 6. loss of the company's reputation; 7. difficult acquisition of capital in the future, 8. loss of investor confidence and others [8].

In practice, numerous cases are known where accountants, with their knowledge and professional knowledge, helped to present a wrong, rather than a realistic (real) image of the company's operations, although the Code of Ethics for Professional Accountants states that an accountant must not knowingly participate in any illegal or illegal activity, nor in activities that damage the reputation of the accounting profession. Also, in practice, it turned out that the reports of large companies that were audited and received a positive opinion from the auditors were false [7].

#### IV. RED FLAGS TO SIGNAL FRAUD

Below are the indicators (red flags) of fraud [4]:

- circumstances that indicate unusual reductions in the assets of the business

entity immediately before filing for bankruptcy;

- dismissal of the workforce, leaving of officers, directors or staff of the business entity immediately before the opening of bankruptcy;
- concealment of assets;
- failure to keep certain business records;
- missing or incomplete business documentation;
- frequent additions and corrections in financial reports and reports on operations;
- impossibility of contacting owners and responsible persons of blocked legal entities;
- impossibility of finding the location of the debtor, that is, the blocked legal entity;
- sudden salary increases, bonuses or cash withdrawals by officers, directors, shareholders or other insiders immediately before the blocking of current accounts and the formal initiation of bankruptcy proceedings;
- transfer of property to insiders, shareholders and relatives immediately before bankruptcy;
- payment or repayment of loans to officers, directors, shareholders, relatives or other insiders immediately before bankruptcy;
- transactions with related legal entities such as representative offices, subsidiaries, parent companies or related corporations immediately before bankruptcy;
- management has a history of prior claims or litigation involving breach of contract, tort or misrepresentation;
- occurrence of thefts, losses or fires immediately before bankruptcy;
- establishment of a new company in the same business branch that precedes bankruptcy, the company had a short lifespan before bankruptcy;

- a company with a good credit rating and good market potential is taken over by a new group of managers and owners who try to hide changes in the ownership structure;
- falsified or “made up” credit references;
- an apparent disproportion between assets and liabilities;
- the business entity employs labor force for a certain period of time;
- the business entity owns and operates with leased equipment.

## V. PENAL PROVISIONS FOR CRIMINAL ACTS

The main goal of regulating economic crime with positive legal regulations is the protection of the economic system and all its participants, and consequently the suppression of crime. Also, the tightening of criminal liability of legal entities should result in a reduction of criminal acts and misdemeanors in the future [2].

Criminal Code of the Republic of Serbia, Sl. glasnik RS, no. 85/2005, 88/2005 - corrected , 107/2005 - corrected , 72/2009, 111/2009, 121/2012, 104/2013, 108/2014, 94/2016 and 35/2019) the consequences due to the existence of criminal acts against the economy and related to bankruptcy are defined.

Causing bankruptcy is regulated by Article 232 of the Criminal Code and provides for prison terms of six months to five years. The mentioned article refers to a responsible person who has the status of a legal entity, who by irrational spending of funds or their disposal for nothing, excessive borrowing, taking on disproportionate obligations, destruction or concealment of property, frivolous conclusion of contracts with persons unable to pay, failure to timely realize claims or other actions which are not in accordance with conscientious business practices, causes bankruptcy and thereby damages the other.

Causing false bankruptcy is regulated by Article 232a of the Criminal Code and provides prison sentences from six months to ten years. The mentioned article refers to a person who has the status of a legal entity who, with the intention of that entity avoiding payment of an obligation, causes the bankruptcy of that legal entity by apparent or real reduction of assets, in such a way that:

1) Statutory prison sentence of six months to five years

2) Cover up all or part of the property of the business entity, sell it ostensibly, sell it below the market value or give it away for free.

3) Enter into fictitious debt agreements or acknowledge non-existent claims.

4) Business books that the subject of business operations is obliged to keep by law are concealed, destroyed or altered in such a way that the business results or the state of assets or liabilities cannot be seen from them, or this state can be presented by creating false documents or in some other way in such a way that, on the basis of it, it can be open bankruptcy.

Provided for a statutory prison sentence of two to ten years if severe consequences for the creditor occurred as a result of the aforementioned criminal acts.

Damage to the creditor is regulated by Article 233 of the Criminal Code and provides for prison sentences from three months to eight years. The mentioned article of the law refers to a responsible person who, in the subject of business operations, knowing that that subject has become unable to pay, by paying off the debt or in another way puts the creditor in a more favorable position and thereby significantly damages another creditor (predicted prison sentence from three months to three years); with the intention of damaging or defrauding the creditor, acknowledges a false claim, draws up a false contract or damages the creditor by some other fraudulent act (prison sentence from three months to three years). A prison sentence of one to eight years if, in part from the above-mentioned points, the creditor has suffered large-scale damage, or if, according to the injured party, forced settlement or bankruptcy proceedings have been initiated as a result.

Abuse of official position is regulated by Article 359 of the Criminal Code and provides prison sentences from six months to twelve years. The mentioned article of the law refers to an official who, by delivering his official position or failing to perform his official duty, obtains any benefit for himself or another natural or legal person, causes any damage to another, or severely violates the rights of another, a prison sentence of six months to five years is provided for; if a benefit in the amount of RSD 450,000.00 was obtained through the execution of the act from the previous paragraph, a prison



sentence of one to eight years is provided, and if the value of the acquired property benefit exceeds the amount of RSD 1,500,000.00, a prison sentence of two to twelve years is provided.

Law on Bankruptcy ("Official Gazette of RS", no. 104/2009, 99/2011 - other law, 71/2012 - decision of US, 83/2014, 113/2017, 44/2018 and 95/2018):

Reporting of a false claim is regulated by Article 204 of the Law on Bankruptcy and foresees a prison sentence of one to three years and a fine in the amount of RSD 500,000.00 to RSD 10,000,000.00 if a false report is made to the court in bankruptcy proceedings conducted according to the provisions of this law claim by submitting false documents or otherwise.

Non-notification of claim settlement is regulated by Article 204a of the Bankruptcy Law and foresees a fine in the amount of RSD 500,000.00 to RSD 10,000,000.00 for a responsible person who, during bankruptcy proceedings, collects his claim from the guarantor or principal debtor within eight days, does not inform the court about the collection of claims from the day of collection.

The disposal of the property of a bankrupt debtor after the opening of bankruptcy proceedings is regulated by Article 205 of the Bankruptcy Law, which provides for a prison sentence of one to five years and a fine of at least RSD 500,000.00, and if the crime was committed for profit, up to RSD 10,000,000.00 for the responsible person who, after the opening of the bankruptcy proceedings and before assuming the duties of the bankruptcy trustee, disposes of things and rights from the bankruptcy estate without compensation or with compensation corresponding to the market value. A prison sentence of one to five years and a fine of at least RSD 500,000.00, and if the criminal offense was committed for self-interest, up to RSD 10,000,000.00 for the responsible person who, after the appointment of the temporary bankruptcy administrator, until he takes office, disposes of the property and rights bankruptcy debtor without compensation or with compensation that does not correspond to the market value.

False representation and concealment of facts in a pre-prepared reorganization plan is regulated by Article 206 of the Bankruptcy Law, which provides for a prison sentence of one to

five years and a fine of at least RSD 500,000.00 and if the criminal offense was committed from self-interest up to RSD 10,000,000.00 for a responsible person who, in a pre-prepared reorganization plan, falsely presents or conceals facts of importance for the court's decision or the creditors' vote on the plan.

Failure to notify the settlement of claims based on financial security contracts and other financial contracts is regulated by Article 206a of the Law on Bankruptcy, which provides for a fine in the amount of RSD 100,000.00 to RSD 2,000,000.00 for a legal entity that does not notify the competent court of the settlement of its claim. on the basis of a contract on financial security, that is, another financial contract through netting. The responsible person in the legal entity will also be fined from RSD 20,000.00 to RSD 150,000.00 for the said offense. The National Bank of Serbia imposes measures and fines on entities over whose operations it exercises control, i.e. supervision, according to special laws regulating its control, i.e. supervisory powers.

## VI. CONCLUSION

Causing bankruptcy is a criminal offense defined by the Riviža Law with the aim of protecting the interests of creditors and other interested parties. Irrational spending of funds or their alienation for nothing, excessive borrowing, taking on disproportionate obligations, destruction or concealment of property or other actions that are not in accordance with conscientious business and thus cause bankruptcy and cause damage to other persons, will be punished in accordance with the defined provisions of the legal regulations that is presented in this paper.

The responsibility of accountants, auditors and state institutions in the financial reporting process itself should be emphasized. Ethical behavior on the part of the aforementioned parties leads to accurate and high-quality financial reports, while otherwise there are inevitable consequences.

An important role in preventing the occurrence of criminal acts is played by: internal controls and company management, external and internal audit and the state. The criminal system of the Republic of Serbia, as defined by the Criminal Code, includes categories of criminal acts: causing bankruptcy, counterfeiting money, money laundering, tax

evasion, abuse of authority in the economy, etc. and for which prison and fine penalties are provided.

#### REFERENCES

- [1] Velimirović, M. (2019). *Stečaj privrednog društva bankrotstvo i sanacija*. Beograd: JP Službeni glasnik.
- [2] Slović, D., & Slović, J. (2019). *Stečajevi i stečajni bilansi*. Beograd, Fineks d.o.o.
- [3] Škarić-Jovanović, K. (2011). Finansijsko izveštavanje preduzeća u bankrotstvu. *Acta economica*, 9(14), 9-36.
- [4] Todorović, Z. (2021). *Forenzika stečaja*. Međunarodno udruženje forenzičkih računovođa i revizora.
- [5] Malinić, D. (2009). Savremeni izazovi integralnog istraživanja kvaliteta finansijskih izveštaja. *Ekonomika preduzeća*, 57(3-4), 138-155.
- [6] Kaparavlović, N. (2011). Uticaj kreativnog računovodstva na kvalitet finansijskog izveštavanja. *Ekonomski horizonti*, 13(1), 155-168.
- [7] Bešlić, D., & Bešlić, I. (2013). Stečaj privrednog društva kao posledica manipulativnog finansijskog izveštavanja. *International Journal of Economic Practice and Policy*, (3-4), 148-159.
- [8] Arežina, N., Stefanović, D., Mizdraković, V., Džamić, V., & Alčaković, S. (2014). Zastupljenost krivičnih dela protiv privrede i privrednih prestupa u Republici Srbiji, privredni kriminalitet i savremeno poslovanje. u: XV Međunarodni naučni skup SINERGIJA. XV Međunarodni naučni skup SINERGIJA, Bijeljina, 1-6.
- [9] Dragan, C., Zoran, J., & Bešić, D. (2016). Privredni kriminalitet u Republici Srbiji u periodu od 2006. do 2015. godine. *Zbornik radova Pravnog fakulteta u Novom Sadu*, 50(2), 569-584.



# Commercializing University Knowledge in Serbia – An Empirical Evidence

Viktorija Petrov<sup>1</sup>, Zoran Drašković<sup>2</sup>, Đorđe Čelić<sup>3</sup>, Zorica Uzelac<sup>4</sup>

<sup>1</sup>Faculty of Economics in Subotica, University of Novi Sad, Subotica, Serbia

<sup>2,3,4</sup>Faculty of Technical Sciences, University of Novi Sad, Novi Sad, Serbia

<sup>1</sup>petrov.viktorija@ef.uns.ac.rs, <sup>2</sup>zoran.draskovic@uns.ac.rs

**Abstract**—Mutual relationship between the university and industry through the exchange of knowledge has become a global trend. Following this trend, many universities have transformed themselves from traditional research universities to entrepreneurial universities with strong ties to industry, thereby encouraging the entrepreneurial activities of their academics. The paper presents research of academic entrepreneurship activity which included 5163 scholars in Serbia. The instrument used in “Commercializing university research in transition economies” was applied. Based on analyzing scholars' survey responses at all Serbian universities, our analysis aimed at defining the profile of scholars who have achieved the highest form of research commercialization - founding of a spin-off company or patenting of an invention.

**Keywords** - commercializing university research, spin-off, licencing a patent, financing commercialization

## I. INTRODUCTION

The role of modern universities is multifaceted [1-5] and encompasses teaching, research, and entrepreneurship function [6]. Universities are changing, implementing new activities, and accepting practices that make them more entrepreneurial [7,8]. Research commercialization requires building a strong external partnerships with ecosystem stakeholders, such as entrepreneurs, universities, local and national governments and private industries [9,10].

Mechanisms of university knowledge transfer, as well as resulting financial

compensation are subjects of research and attract a lot of attention from both researchers and policy makers in developed [11] and developing economies [12].

This work is an expression of entrepreneurial activity among scholars in Serbia. The research was conducted on the basis of data collected in 2018 and 2019, and the analysis performed based on the answers of 334 scholars/respondents. The instrument used in the “Commercializing university research in transition economies” [13] was applied.

The main goal of this paper is understanding the profiles of scholars who have achieved the highest form of research commercialization - founding of a spin-off company, or patenting of an invention.

## II. ACADEMIC ENGAGEMENT

Universities are recognized as basic generators of knowledge and as such occupy a special place in modern society. Adding to them a third mission in the form of technological transfer, it becomes increasingly important to measure the contribution of universities to economic growth. The commercialization of academic knowledge, including the patenting and licensing of inventions, as well as academic entrepreneurship [14,15] is becoming an increasingly important research field, both for the academic community and for policy makers.

Commercialization represents a basic example of generating academic impact, as it represents an immediate and measurable market

confirmation of acceptance of the results of academic research [16]. Commercialization represents the basic and most important form of contribution of the academic community to society and the economy. Academic engagement represents broader term than commercialization, and implies a way of transferring university knowledge. It can be defined as scientifically based cooperation between academic and non-academic organizations [17]. Collaboration can be formally defined as: joint research, contract research, consulting, informal counseling, or networking with collaborators.

Academic engagement is often called informal technology transfer, and is nothing new. On the contrary, it has a well-established practice, especially at universities that specialize in teaching technically oriented skills. The most common types of academic engagement are: securing internships for students in the companies with which formal cooperation has been established, educating profiles for a specific profession for which market need has been established, or developing profiles according to the requirements of companies that rely on the university. The basic prerequisite of academic engagement is direct contact between organizations. There is usually a quid-pro-quo agreement of a purely financial nature between the participants of the cooperation. Scholars work for compensation, or for free access to company databases which could allow them to advance their careers by publishing scientific papers, or for possibility to participate in scientific projects. Non-academic partners have a motive to improve their market position using academic knowledge and skills by developing new ideas/products/services or improving existing ones.

After established cooperation and academic engagement, commercialization in the form of academic entrepreneurship could follow [18] with the aim of commercializing a patent, invention, or unprotected expertise in the form of university spin-offs, spin-outs or start-up companies. This definition of commercialization emphasizes academic engagement with the sole purpose of financial gain, and that is why commercialization is a narrower, more precise term [19].

Although they can be demarcated and clearly defined, the terms used overlap and are often used as synonyms. Perhaps it is good to underline that in practice, the standard introduction of

scholars (academics) into the market space is first through informal cooperation in the form of projects and academic engagement, while commercialization is always the next phase and for scholars it represents a huge step out of their comfort zone.

Academic engagement, with all its nuances and aspects, is unfortunately driven solely by the personal motives of scientists. Motivating researchers at universities for the commercialization of scientific research is a particularly important issue, perhaps a key one, for the establishment of entrepreneurially oriented universities that would integrate much easier into various types of partnerships with the economy, i.e. innovation systems.

The most common barriers to the commercialization of scientific research are: the overload of teaching and administrative work related to teaching in the case of teaching staff, as well as the absence of the impact of commercialization on the academic career, both for researchers and teachers. Therefore, commercialization is most often seen as a burden and an unnecessary waste of time, with a misunderstanding of the value of the potential market application of research for society. On the other hand, there is also a fear that active engagement in commercialization will slow scientists down in their academic work [20].

### III. THE IMPORTANCE OF MONITORING AND MEASURING INNOVATIVE ACTIVITY

The degree of success of the development of intellectual property as a result of creativity, and applicability of that creation for useful and commercial purposes, is reflected through intellectual property rights applications [21].

Assessment and monitoring of the innovation landscape of national economies is carried out by World Intellectual Property Organization (WIPO). With the simple goal of determining how to find metrics and approaches that better capture the richness of innovation in society and go beyond such traditional measures of innovation as the number of research articles and the level of research and development (R&D) expenditures, the Global Innovation Index (GII) was introduced in 2007. The index includes three sets of parameters for evaluating and comparing the development of an economy's innovative environment. The first set includes Science and innovation investment, in the form of: scientific publications, R&D expenditures both in business

and government institutions, international patent filings, and venture capital deals. The next set of indicators includes Technological progress measured by: microchip transistor count, costs of renewable energy (solar photovoltaic and onshore wind) and drug approvals. The last set of indicators includes socioeconomic impact as: labor productivity, life expectancy, and carbon dioxide emissions.

The Science and innovation investments part is extremely important for this paper because it contains the two highest forms of academic engagement of scholars in the form of entrepreneurial activities - patenting and spin-offs.

For Serbia, which belongs to the upper-middle income group, the GII 2022 places it at 55th place [22], which is one position worse than the rank in the previous year [23], i.e. two positions worse compared to the period 2 years ago. The rank considering only Innovation Input is 55, and the rank for Innovation Output is worse than overall - 58.

When analyzing patents in our country in the pillar Knowledge and technology outputs, section Knowledge creation, for Patents by origin/bn PPP\$ GDP, Serbia is ranked 61st, and for PCT patents by origin/bn PPP\$ GDP, Serbia is ranked 57th. In that part, for Serbia, the number of published works, i.e. Scientific and technical articles/bn PPP\$ GDP, is set aside as a strength. And on the basis of this index, the orientation of our scientists towards publication, rather than commercialization of their research, is confirmed. On the other hand, in the pillar Market sophistication, in the section Investment, data is unavailable for almost all parameters, except for market capitalization, for which it is available but outdated. For the parameters: Venture capital investments, deals/bn PPP\$ GDP; venture capital recipients, deals/bn PPP\$ GDP; as well as venture capital received, value, % GDP; there is no data for Serbia, and it ranks 94th. All of the above confirms that our market isn't sufficiently attractive for VC activities.

Comparing the performance of Serbia with similar economies, primarily those in the same income group, it is easiest to make comparisons with Montenegro and Bosnia and Herzegovina. Montenegro recorded a huge drop in 2022, as it fell from 50th to 60th place, and thus lost its advantage over Serbia. In 2022, Bosnia and Herzegovina placed 70th, compared to 75th

in 2021, and thus, although it remained behind Serbia and Montenegro, it still improved.

In order to provide more than a simple ranking of intellectual property offices and to show the activity of filing patent applications in a wider geographical area [24] an insight into the number of accepted patent applications in selected middle-income countries in 2020 was conducted. Countries were selected based on geographic distribution and data availability. The most patent applications were approved in the designated office for the protection of intellectual property in the OAPI (Organisation Africaine de la Propriété Intellectuelle) as many as 490, followed by 461 in Belarus, and 357 applications in Morocco. In terms of the number of patent applications, Serbia is at the bottom with 59 patent applications in 2020 [24].

Observing the trend in the number of registered patent applications in Serbia over the last decade, a slight fluctuation is noticeable and the annual number of patent applications ranges from 234 recorded in 2012 to a maximum of 333 in 2013 [24].

Human creativity, especially the one with economic profitability, which is reflected in applied for and registered intellectual property rights, is something that should be encouraged in Serbia. Registered intellectual property rights have the greatest chance of achieving utility value.

#### IV. RESEARCH METHODOLOGY

For this research, we used a Survey instrument that was carefully developed and applied [13] in transition, i.e. post-socialist and developing economies: Belarus, Kazakhstan and Azerbaijan.

The instrument itself is made up of 4 parts. The first part includes general information about the respondents, such as: age, work experience, title, position, research field, faculty, and university. The second block of questions is devoted to the academic progress in terms of number of works published in Serbian or international journals in the last 5 years.

The next part of the questionnaire is dedicated to the academic engagement of researchers, in the form of undertaking some of the following activities:

- honorarium for conferences, lectures, etc.;

- units as winning a grant;
- consulting, mentoring, coaching;
- selling products of your research without establishing a firm;
- licensing of patents;
- establishing a spin-off (new business).

And the last part of the questionnaire referred to the sources from which the researcher's entrepreneurial activity was financed. The answers offered were:

- government grants;
- foreign (EU) grants;
- university resources;
- own resources;
- private capital market;
- venture capital business.

The empirical analysis is based on a novel dataset collected via online survey over the four months from September 2018 to January 2019 in Serbia. Academic entrepreneurship survey required optional participation.

#### A. Sample

There are 18 universities in Serbia, 8 of which have been founded and are financed by the state, while 10 are privately owned. In our analysis, we first devoted our efforts to obtaining contact information of scholars. Email information was collected for the 5,163 established scholars via the universities' web-pages and a database was created. In total 2,106 questionnaires were opened, 408 showed some activity, while 43 emails bounced.

With 5,163 emails sent, and 408 responses received, we had response rate of 7.9%. After a thorough examination of responses 74 questionnaires were excluded from further analysis due to the high proportion of missing data and 334 were regarded as valid.

Only a subsample of individual observations were defined as academically entrepreneurial, and provided information on commercialization income as a share of total income, as well as other commercialization activity characteristics. The subsample of scholars with reported commercialization activity consists of 260 respondents.

The Academic entrepreneurship survey was conducted on the entire territory of Serbia and included scholars from all universities. The majority of valid answers came from the University of Novi Sad (34.44%) and the University of Belgrade (32.63%), while the response from other universities was significantly lower: University of Kragujevac (9.9%), University of Nis (3.3%), University of Novi Pazar (0.6%) and University of Pristina temporarily headquartered in Kosovska Mitrovica (0.6%), others (1%), while 55 respondents (16.5%) did not want to name their university. Looking at university ownership, the sample included 3 respondents from private, and 331 respondents from state universities. An overview of the demographic characteristics of the respondents is presented in Table I.

In relation to the age, the predominant number of respondents, 115 of them (34.4%) were from 30 to 39 years of age, while 78 of them (23.4%) were from 50 to 59 years of age, followed by 71 respondents (21.3%) that were from 40 to 49 years of age. Age groups that are presented by the youngest and oldest scholars are

TABLE I. DEMOGRAPHICS OF THE SAMPLE.

<i>Characteristics</i>		<i>frequency</i>	<i>%</i>
<i>Age</i>	up to 29	45	13.5
	30-39	115	34.4
	40-49	71	21.3
	50-59	78	23.4
	60+	24	7.2
<i>Work experience</i>	up to 5	42	12.6
	6-10	85	25.4
	11-20	91	27.2
	21-30	68	20.4
	31+	47	14.1
<i>Title</i>	PhD	257	76.9
	MSc	65	19.5
	MPhil	10	3.0
	Graduate	1	0.3
<i>Position</i>	Specialist	1	0.3
	Full Professor	81	24.3
	Assoc. Professor	98	29.3
	Asst. Professor	59	17.7
	Lecturer	11	3.3
	Vocational Prof.	2	0.6
<i>University</i>	Research fellow	83	24.9
	Novi Sad	115	34.4
	Belgrade	109	32.6
	Kragujevac	33	9.9
	Niš	11	3.3
	Novi Pazar	2	0.6
	Priština	2	0.6
Other	5	1.0	
n/a	55	16.5	
<b>Total sample Size (n) = 334</b>			

much less represented with 13.5%, and 7.2% respectively.

Regarding work experience, the distribution was as follows: 91 of respondents (27.2%) were employed between 11 and 20 years, 85 (25.4%) between 6 and 10 years, 68 (20.4%) between 21 and 30 years, while the groups with 31+ and up to 5 years of employment were much less represented, with 14.1% and 12.6% respectively.

The most represented academic title by far in our sample was PhD with 257 (76.9%), followed by MSc with 65 (19.5%) and MPhil 10 (3%) of responses. One respondent each (0.3%) reported a graduate and a specialist title.

Most of the respondents held teaching positions - 238 (71.2%), research fellow - 83 (24.9%), lecturer - 11 (3.3%), and professor of vocational studies - 2 (0.6%).

## V. ANALYSIS AND DISCUSSION

Analyzing the demographic characteristics of the respondents who reported some form of research commercialization and those who answered that they were not active in commercialization, it was evident that among the respondents who had no experience in commercialization, the most numerous were young people at lower positions and with the least work experience.

It was interesting to note that some form of commercialization was reported at all universities covered by the survey, as well as at each position held.

A subsample of individual observations were defined as academically entrepreneurial, and provided information on commercialization income as a share of total income as well as other commercialization activity characteristics. The subsample of scientists with reported commercialization activity consists of 260 respondents, with reported types of commercialization presented in Fig.1.

Respondents who were engaged in some of the academic research activities were analyzed separately, and those who achieved the highest degree of scientific work commercialization were singled out from that group.

After selecting respondents who founded their own spin-off companies - 27 (10.38%), and those who reported holding a patent - 16 (6.15%), followed a detailed analysis of their basic characteristics

### A. Comparison Between Scholars with Spin-Offs and Patents

The respondents who founded their own spin-off companies were predominantly from the field of ICT, holding the title of full professor, and employment ranging between 11 and 20 years at the University of Novi Sad.

On the other hand, the respondents who registered their patents were mostly from the field of engineering, holding titles of full or assistant professor, with employment ranging

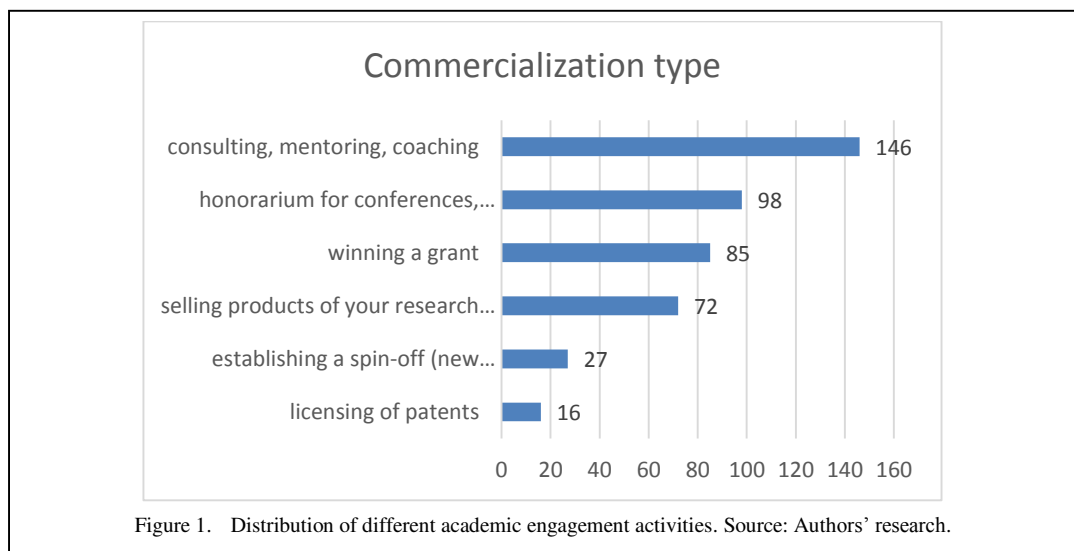



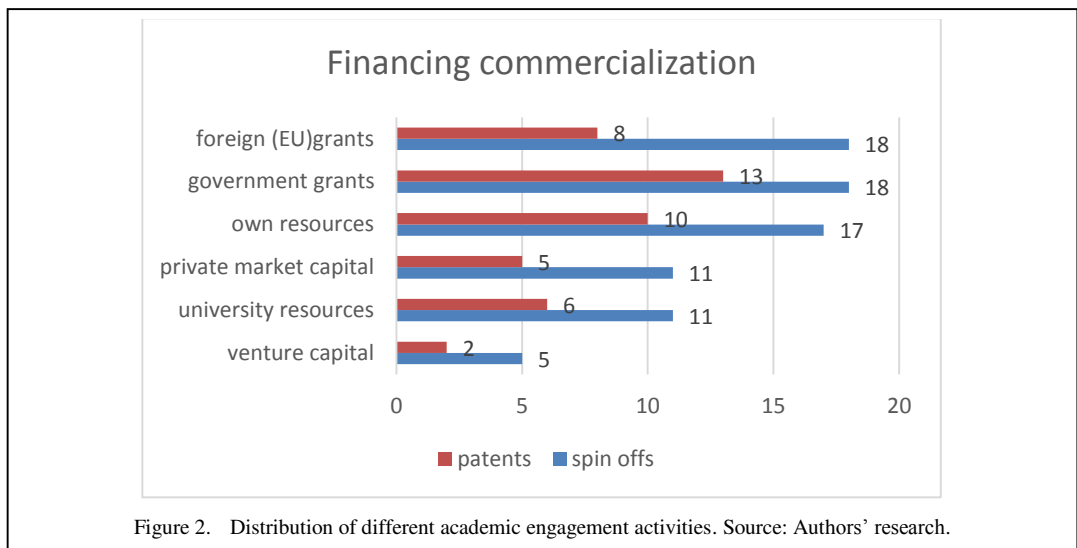

between 6 and 10 years at the University of Novi Sad, or University of Belgrade.

What is perhaps the most interesting result of the research is an insight into the funding sources of the entrepreneurial ventures of scholars, which is shown in Fig.2.

Most of respondents who founded spin-off companies reported that a large share funding came from project financing, whether foreign or domestic, as well as from their own funds. The participation of private capital, university resources, and venture capital was considerably smaller.

Among respondents who registered patents, the most common types of financing were: state grants, own funds, foreign grants, and to a lesser extent university resources, private capital, and VC.

Since the questionnaire did not offer an exclusive answer to the question of the type of academic entrepreneurship, there was a possibility for the respondents to opt for both a spin-off and a patent at the same time, which 4 respondents did. Respondents were from the fields of: engineering (2), bioscience and ICT, from the University of Novi Sad (2), University of Belgrade, and one n/a. The respondents held titles of full professor (2) or assistant professor (2), with work experience of 6 to 10 years (2), 11 to 20 (1) and 21 to 30 (1). All respondents reported funding from project financing, both foreign and domestic.

## VI. CONCLUSION

The role of modern universities encompasses teaching, research and entrepreneurship functions. Research commercialization requires building strong external partnerships with ecosystem stakeholders. Mechanisms of transfer of university knowledge, as well as financial compensation from the same, are subjects of continued research. The paper presents results of the research of academic entrepreneurship activity among scholars in Serbia. Questionnaire was sent to 5.163 scholars, and the analysis was carried out on the answers of 334 respondents. The instrument used in the paper "Commercializing university research in transition economies" was applied.

On the basis of the conducted analysis, the profile of scholars who achieved the highest form of research commercialization - establishment of a spin-off company or patenting - was defined. The respondents who founded their own spin-off companies were predominantly from the field of ICT, holding the title of full professor, with work experience of between 11 and 20 years at the University of Novi Sad. On the other hand, the respondents who registered patents were mostly from the field of engineering, holding the title of full professor or assistant professor with employment ranging from 6 to 10 years at the University of Novi Sad, or University of Belgrade.

Further research could deepen the analysis and determine the factors that can encourage a greater number of scholars to commercialize

their research, and determine possible barriers that are present at universities in Serbia. It should focus on determining guidelines for the promotion of entrepreneurial activities in the academic community, while at the level of university management it should determine guidelines for the shift towards greater commercialization of research.

#### ACKNOWLEDGMENT

The research was supported by the Faculty of Technical Sciences, University of Novi Sad: project “Application of general disciplines in technical and information sciences” of the Department of Fundamental Sciences.

#### REFERENCES

- [1] Bishop, K., D’Este, P. & Neely, A. (2011). Gaining from interactions with universities: multiple methods for nurturing absorptive capacity. *Research Policy*, 40 (1), 30-40.
- [2] Etzkowitz, H., Webster, A., Gebhardt, C. & Cantisano, B. R. (2000). The future of the university and the university of the future: evolution of ivory tower to entrepreneurial paradigm. *Research Policy*, 29, 313-330.
- [3] Goddard, J., Hazelkorn, E., Kempton, L. & Vallance, P. (2016). *The Civic University - The Policy and Leadership Challenges*, 4.
- [4] Hvide, H. K. & Jones, B. F. (2016). *University innovation and the professor’s privilege*. National Bureau of Economic Research No. w22057. Available at: [https://www.nber.org/system/files/working\\_papers/w22057/w22057.pdf](https://www.nber.org/system/files/working_papers/w22057/w22057.pdf)
- [5] Thomas, E. & Pugh, R. (2020). From ‘Entrepreneurial’ to ‘Engaged’ Universities: Social Innovation for Regional Development in the Global South. *Regional Studies*, 54, 1-13.
- [6] Audretsch, D. B. (2014). From the entrepreneurial university to the university for the entrepreneurial society. *The Journal of Technological Transfer*, 39(3), 313-321.
- [7] Siegel, D. S. & Wright, M. (2015). Academic Entrepreneurship: Time for a Rethink? *British Journal of Management*, 26(4), 582-595.
- [8] Cunningham, J.A. & Link, A.N. (2015). Fostering university-industry R&D collaborations in European Union countries. *International Entrepreneurship Management Journal*, 11, 849–860.
- [9] Acs, Z., Autio, E. & Szerb, L. (2014). National Systems of Entrepreneurship: Measurement issues and policy implications. *Research Policy*, 43(3), 476-494.
- [10] Bozeman, B. & Gaughan, M. (2007). Impacts of grants and contracts on academic researchers’ interactions with industry. *Research Policy*, 36, 694-707.
- [11] Kalar, B. & Antoncic, B. (2015) The entrepreneurial university, academic activities and technology and knowledge transfer in four European countries. *Technovation*, 36-37, 1-11.
- [12] Marozau, R. & Guerrero, M. (2016). Conditioning Factors of Knowledge Transfer and Commercialisation in the Context of Post-Socialist Economies: The Case of Belarusian Higher Education Institutions. *International Journal of Entrepreneurship and Small Business*, 27(4), 441-462.
- [13] Belitski, M., Aginskaja, A. & Marozau, R. (2019). Commercializing university research in transition economies: technology transfer offices or direct industrial funding? *Research Policy*, 48(3), 601-615.
- [14] Lockett, A., Wright, M. & Franklin, S. (2003). Technology Transfer and Universities’ Spin-out Strategies. *Small Business Economics*, 20(2), 185-200.
- [15] Di Gregorio, D. & Shane, S. (2003). Why do some universities generate more start-ups than others? *Research Policy*, 32, 209–227.
- [16] Markman, G., Siegel, D. & Wright, M. (2008). Research and technology commercialization. *Journal of Management Studies*, 45, 1401-1423.
- [17] Perkmann, M. and Walsh, K. (2007) „University–industry relationships and open innovation: Towards a research agenda“. *International Journal of Management Reviews*, 9(4), 259-280.
- [18] Würmseher, M. (2017). To each his own: Matching different entrepreneurial models to the academic scientist’s individual needs. *Technovation*, 59, 1-17.
- [19] Petrov, V. (2022) Mogućnosti prevazilaženja jaza između naučno – istraživačkog rada i komercijalizacije In Mosurovic Ružičić, M., Lazarevic Moravčević, M., Paunovic, M. *Nauka i inovacije kao pokretači privrednog razvoja* (pp: 1-21).
- [20] Van Looy, B., Ranga, M., Callaert, J., Debackere, K., Zimmermann, E. (2004). Combining entrepreneurial and scientific performance in academia: towards a compounded and reciprocal Matthew-effect? *Research Policy*, 33(3), 425-441.
- [21] Jelisavac Trošić, S. (2012). Položaj Srbije u međunarodnim tokovima intelektualne svojine in Bjelić, P. & Dimitrijević, D. (2012). *Položaj Srbije u savremenim međunarodnim ekonomskim odnosima*, Institut za međunarodnu politiku i privredu (pp: 128-151).
- [22] World Intellectual Property Organization (2022). *Global Innovation Index 2022: What is the future of innovation-driven growth? 15th edition*. Available at: <https://www.wipo.int/globalinnovationindex/en/2022/>
- [23] World Intellectual Property Organization (2021). *Global Innovation Index 2021: Tracking Innovation through the COVID-19 Crisis*. Available at: [https://www.wipo.int/global\\_innovation\\_index/en/2021/](https://www.wipo.int/global_innovation_index/en/2021/)
- [24] *World Intellectual Property Organization Accessed November 2022* Available at: [https://www.wipo.int/ipstats/en/statistics/country\\_profile/](https://www.wipo.int/ipstats/en/statistics/country_profile/)



# Understanding Employee Innovative Behavior in Serbia: A Comparison with EU Country

Bojana Milić<sup>1</sup>, Milan Lečić<sup>2</sup>, Jelena Spajić<sup>3</sup>, Dunja Bošković<sup>4</sup>, Danijela Lalić<sup>5</sup>

<sup>1,2,3,4,5</sup>University of Novi Sad, Faculty of Technical Sciences, Novi Sad, Serbia

<sup>1</sup>bojana.milic@uns.ac.rs, <sup>2</sup>lecic.di16.2017@uns.ac.rs, <sup>3</sup>stankovicj@uns.ac.rs,  
<sup>4</sup>dunja.vujcic@uns.ac.rs, <sup>5</sup>danijelalalic@uns.ac.rs

**Abstract**—This paper investigates the differences between Serbia and Slovenia in structural model that examines the relationship between leadership and innovative work behavior, observed through several mediators: innovative climate, internal trust and organizational commitment. The quantitative research was conducted from May through October 2021. After contacting companies in Serbia and Slovenia, the questionnaire consisting of 41 items was distributed through Google Form platform. The final sample consisted of 1114 employees working in Serbian and Slovenian companies on managerial and non-managerial positions. The analysis was conducted with SmartPLS multigroup analysis. Results indicate that internal trust can have significant role in initiating and directing innovative work behavior. The practical implications are discussed.

**Keywords** - leadership, innovative behavior, PLS-MGA

## I. INTRODUCTION

When investigating statistical models, authors frequently use different samples, and often overlook differences in path coefficients of different groups. One can't help but wonder: is there a statistical difference between the path coefficients of observed samples, and how they can affect the generalization of model? In this paper results of multi group analysis with PLS structural equation modelling (MGA-PLS) are presented. The proposed model aims to investigate how leadership affects innovative behavior of employees through following mediators: innovative climate, internal trust and organizational commitment. The group

differences that could be identified can help better understanding of proposed theoretical framework for innovative work behavior.

## II. THEORETICAL BACKGROUND

### A. Leadership

The leader-member-exchange theory (LMX) argues that high-quality exchanges between leaders and their followers are crucial for successful leadership – when followers were given greater responsibility, they tend to work more innovatively in order to exceed their leader's expectations [1,2]. Leadership (L) is identified as crucial factor that impact creativity and innovative work behavior [3]. If leaders want to boost and benefit from their follower's creativity, they need to put in the effort to build trust and respect between team members [4].

### B. Innovative Climate

While interacting with their followers, leaders also influence a special type of organizational climate – an innovative climate (IC) [5]. This form of climate is considered crucial for innovative organizations since it supports and promotes change and innovation, and encourages employees to develop, share and work on their ideas [6,7]. Innovative climate has motivational effect on employees, by providing them a positive environment to pursue creative and innovative ideas [8]. Employees can increase their innovative work behavior, if they feel that they have freedom in their work. These

employees will show initiative, present new ideas, and will try to find a way to implement them [9].

### C. Internal Trust

Internal trust (IT) is expressed as climate of trust between employees in organization, and their positive expectations about their role, relationships with other employees and their co-dependence. The organizations with strong feeling of internal trust are considered more successful, creative and innovative [10]. Leaders can develop a feeling of trust among their followers, by manifesting a trusting behavior themselves by assigning important tasks or entrusting confidential information [11]. The different styles of leadership, leader's actions and their attitudes are found to be important drivers of internal trust in organizations [12,13]. Internal trust is found to be an important factor for innovation [14], but also it is found that lack of trust may hinder the creation of an innovative climate [15].

### D. Organizational Commitment

Employees are psychologically connected to their organization through organizational commitment (OC). Committed employees will adopt organizational values, mission and vision, will work hard and put in a lot of effort to achieve company's goals [16]. The results of previous studies indicate that leader's behavior has a strong impact on organizational commitment [17]. Also, positive relationship between innovative climate and organizational commitment has been found [18].

### E. Innovative Work Behavior

Innovative work behavior (IB) imply a wide range of behaviors that aid: idea generation, idea promotion and idea implementation [19]. Over the years, different factors are found to have a positive impact on innovative work behavior. Innovative climate is found to have a mediating effect on innovative work behavior [20]. On the other hand, it is found that leaders through their vision, expertise, mentoring but also through developing supportive culture and intellectual stimulation, can motivate employees to develop innovative work behavior [21].

Based on the theoretical background and the results of previous research, the research model was conceptualized (Fig.1) and hypotheses were developed (Table I).

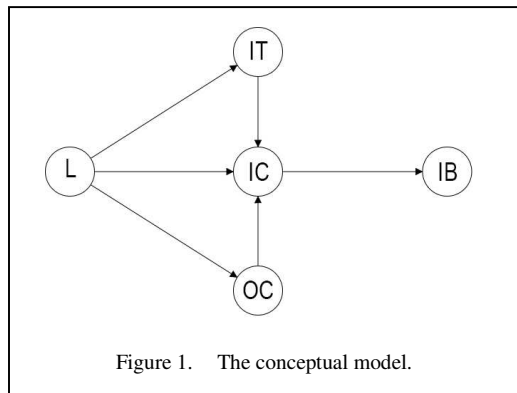

Figure 1. The conceptual model.

TABLE I. RESEARCH HYPOTHESES.

Hypotheses	Relationship	
H1	$L \rightarrow IC$	There is no statistically significant difference between Serbian and Slovenian sample.
H2	$IC \rightarrow IB$	
H3	$L \rightarrow IC \rightarrow IB$	
H4	$L \rightarrow IT$	
H5	$IT \rightarrow IC$	
H6	$L \rightarrow IT \rightarrow IC$	
H7	$IT \rightarrow IB$	
H8	$L \rightarrow IT \rightarrow IC \rightarrow IB$	
H9	$L \rightarrow OC$	
H10	$OC \rightarrow IC$	
H11	$L \rightarrow OC \rightarrow IC$	
H12	$IB \rightarrow IB$	
H13	$L \rightarrow OC \rightarrow IC \rightarrow IB$	

## III. METHODOLOGY

### A. Measurement

The total of 41 items were used to measure five constructs: (1) LMX-7 scale was used to measure LMX leadership – 7 items [22]; (2) subscale of psychological climate measure was used to measure innovative climate – 5 items [23]; (3) items used in previous study were adapted in order to measure internal trust – 4 items [24]; (4) the Organizational Commitment Questionnaire (OCQ) was used to measure organizational commitment -15 items [25]; (5) Innovative Work Behavior Scale (IWBS) was used to measure innovative behavior – 10 items [26]. The selected measurements were applied and validated in previous studies and showed satisfactory levels of validity and reliability.

The questionnaire was translated following double-translation method [27] from English to Serbian and Slovenian language. Confirmatory factor analysis provided similar values for

measures of internal consistency, validity and reliability for both questionnaires.

### B. Data Collection

The research was conducted from May to October 2021. Some of leading Serbian and Slovenian companies were contacted with invitation to participate in this study. Online questionnaire was sent to companies who responded positively, via Google Form platform.

### C. Sample Characteristics

The total of 1114 employees from Serbian (54%) and Slovenian (46%) companies were included in the final sample. There were 579 women respondents (52%) and 535 (48%) male respondents. The total of 350 respondents were working on managerial positions (31,4%), while 764 respondents were working on non-managerial positions (68,6%). The total of 413 respondents (37,1%) were working in public sector, 694 respondents (62,3%) were working in private sector, while 7 respondents (0,6%) worked in other types of company ownership.

### D. Statistical Analysis

Statistical analysis was performed using SmartPLS 4 software [28]. The conceptual model was analyzed with PLS-SEM algorithm and bootstrapping. The analysis of measurement model showed that convergent validity, internal consistency reliability and discriminant validity were established. The structural model was tested for collinearity, and results of path analysis, values of coefficient of determination ( $R^2$ ) indicated a good model fit. Finally, the group differences were examined with Consistent Bootstrap multigroup analysis.

## IV. RESULTS

The Smart PLS multi-group analysis allows testing the hypothesis that the path coefficients between two groups are not significantly different. PLS-MGA approach based on bootstrap analysis allows the comparison of structural model parameters between different groups [29]. PLS-MGA analysis followed three steps, suggested by Hair and colleagues [30]:

- generating groups;
- test for invariance;
- permutation analysis.

### A. Generating Groups

In the first step, the groups for two observed countries were generated. It is important to obtain the minimum group size to ensure the predictive power of test. For a total of 5 variables in the conceptual model, 45 observations must be obtained in order to achieve the statistical power of 80%, and  $R^2$  value of 0.25 at the statistical significance level of 95% [31]. The final sample exceeded the minimum sample size.

### B. Test for Invariance

Testing for measurement invariance, ensures that the differences between groups identified in multigroup analysis originate from real differences in structural relationship and are not the result of different interpretation of specific measures. Measurement invariance of composite models (MICOM) follows three step procedure [32]:

- MICOM step 1: configural invariance;
- MICOM step 2: compositional invariance;
- MICOM step 3: equality of composite mean values and variances.

Configurable invariance was established by: (1) using identical indicators in both Serbian and Slovenian model; (2) identical data processing, (3) identical PLS algorithm setting.

Compositional invariance examines correlation of composite scores (c), and assumes the value of 1. The results of second step in MICOM analysis (Table II), suggest that c value is not significantly lower than 1, concluding that compositional invariance is established.

The complete invariance of measurement is achieved when there is no significant difference in mean value and variance between groups. The results presented in Table III and IV, suggest that partial measurement invariance is established.

Based on the results of MICOM analysis, as well as recommendations found in literature [32], a PLS-MGA analysis was carried out.

TABLE II. MICOM STEP 2.

Composite	c	95% conf. interval	Comp. invariance?
L	0.999	(0.999-1)	YES
IC	1.000	(1.000-1)	YES
IT	1.000	(1.000-1)	YES
OC	1.000	(1.000-1)	YES
IB	1.000	(1.000-1)	YES

TABLE III. MICOM STEP 3A.

Composite	Mean		
	Mean diff.	95% conf. interval	Equal mean?
L	0.238	(-0.126-0.124)	NO
IC	0.122	(-0.116-0.117)	NO
IT	0.026	(-0.120-0.109)	YES
OC	0.138	(-0.123-0.106)	NO
IB	0.107	(-0.126-0.117)	YES

TABLE IV. MICOM STEP 3B.

Composite	Variance		
	Mean diff.	95% conf. interval	Equal var.?
L	0.156	(-0.163-0.165)	YES
IC	0.020	(-0.166-0.160)	YES
IT	0.003	(-0.167-0.157)	YES
OC	-0.202	(-0.163-0.167)	NO
IB	0.000	(-0.161-0.177)	YES

C. Multigroup Analysis

Figs. 2 and 3 present the structural models with path coefficients and R<sup>2</sup> values for Serbian (A) and Slovenian (B) samples. The differences between the two groups are noticeable for both path coefficients as well as R<sup>2</sup> values.

Further analysis evaluated their statistical significance. In the comparison of two group in PLS-MGA analysis, Serbia group showed statistically significant higher values of path coefficients than Slovenia group in all relationships containing construct internal trust. No other path coefficients showed statistical difference (Table V).

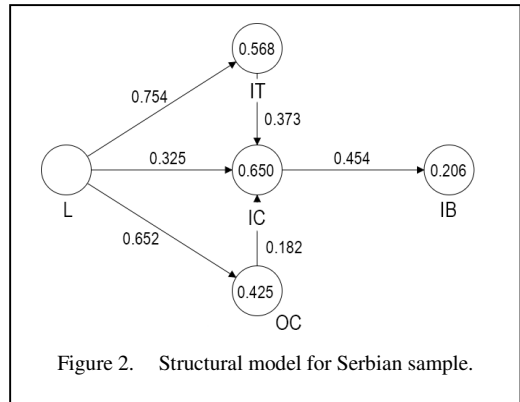

Figure 2. Structural model for Serbian sample.

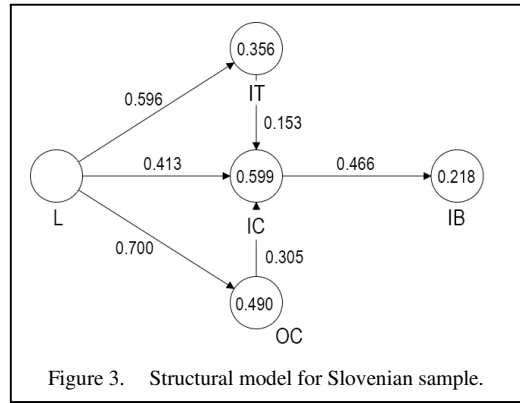

Figure 3. Structural model for Slovenian sample.

TABLE V. THE RESULTS OF MULTIGROUP ANALYSIS.

Relationship	Bootstrap MGA		
	Diff. (A-B)	P (A>B)	P (B>A)
L → IC	-0.0043	0.491	0.509
IC → IB	-0.004	0.946	0.054
L → IC → IB	-0.020	0.536	0.464
L → IT	0.142	<b>0.001</b>	0.999
IT → IC	0.165	<b>0.016</b>	0.984
L → IT → IC	0.136	<b>0.002</b>	0.998
IT → IB	0.070	<b>0.030</b>	0.970
L → IT → IC → IB	0.058	<b>0.005</b>	0.995
L → OC	-0.038	0.396	0.604
OC → IC	-0.097	0.164	0.836
L → OC → IC	-0.069	0.121	0.879
OC → IB	-0.059	0.890	0.110
L → OC → IC → IB	-0.030	0.192	0.808

## V. DISCUSSION

SmartPLS software is often used for complex structural models with many constructs, indicators and relationship to test a theoretical framework from a prediction perspective [33]. When arguing new theory, authors often fail to report the possible group differences in their sample. If reported, they usually use traditional parametric and non-parametric tests that analyze group differences for one construct at a time, which is why there is no possibility to see how group differences affect the functioning of the model as a whole. SmartPLS multigroup analysis allowed us to investigate the possible differences between two countries in one research sample, while proposing a new theoretical framework aimed to further understand the origin, development and directing of innovative work behavior in organizational context. The results of multigroup analysis (Tables V and VI) suggest that internal trust is affected by group differences in sample, since all relationships in model that include this construct showed statistically higher values for Serbian sample. This is an interesting finding since Serbia and Slovenia are considered to share similar profiles of cultural dimensions, and the both countries are considered to have collectivistic orientation [34]. However, the found differences could be explained through different historical circumstances that these two countries have gone through.

TABLE VI. THE RESULTS OF HYPOTHESIS TESTING.

Hypotheses	Relationship	Decision
H1	L → IC	Supported
H2	IC → IB	Supported
H3	L → IC → IB	Supported
H4	L → IT	Not supported
H5	IT → IC	Not supported
H6	L → IT → IC	Not supported
H7	IT → IB	Not supported
H8	L → IT → IC → IB	Not supported
H9	L → OC	Supported
H10	OC → IC	Supported
H11	L → OC → IC	Supported
H12	IB → IB	Supported
H13	L → OC → IC → IB	Supported

## VI. CONCLUSION

The results of a study that investigated trust, confidence and social environment in post-communist societies, indicate that countries that have experienced fewer economic and political turbulences show higher levels of trust. These results indicate that sudden and negatively perceived change can completely destroy trust in countries recovering from or going through transition [35]. Other results suggest that supporting and encouraging employees to generate and implement new ideas, will help internal trust to boost innovative behavior [36]. The results of this paper highlight the importance of observing the broader context that goes beyond the boundaries of the organization, which could be of crucial importance for initiating innovative behavior in multinational companies.

### ACKNOWLEDGMENT

The results presented in this paper are part of the research within the project “Improvement of teaching processes at DIEM through the implementation of the results of scientific research in the field of Industrial engineering and management”, Department of Industrial Engineering and Management, Faculty of Technical Sciences in Novi Sad, University of Novi Sad, Republic of Serbia.

### REFERENCES

- [1] Northouse, P. (2009). *Introduction to leadership: Concepts and practice*. Thousand Oaks: Sage.
- [2] Graen, G. B. & Uhl-Bien, M., (1991). The Transformation of Professionals into Self-Managing and Partially Self-Designing Contributors: Toward a Theory of Leadership-Making. *Journal of Management Systems*, 3(3), 25-39.
- [3] Jung, D. I., Chow, C., & Wu, A. (2003). The role of transformational leadership in enhancing organizational innovation: Hypotheses and some preliminary findings. *The leadership quarterly*, 14(4-5), 525-544.
- [4] Catmull, E. (2008). *How Pixar fosters collective creativity*. Boston, MA: Harvard Business School Publishing.
- [5] Ekvall, G. (1996). Organizational climate for creativity and innovation. *European journal of work and organizational psychology*, 5(1), 105-123.
- [6] Isaksen, S. G., & Ekvall, G. (2010). Managing for innovation: The two faces of tension in creative climates. *Creativity and innovation management*, 19(2), 73-88.
- [7] Scott, S. G., & Bruce, R. A. (1994). Determinants of innovative behavior: A path model of individual innovation in the workplace. *Academy of management journal*, 37(3), 580-607.



- [8] Zhang, N., Zhou, Z., Zhan, G., & Zhou, N. (2021). How does online brand community climate influence community identification? The mediation of social capital. *Journal of Theoretical and Applied Electronic Commerce Research*, 16(4), 922-936.
- [9] Amabile, T.M., Conti, R., Coon, H., et al. (1996) Assessing the Work Environment for Creativity. *Academy of Management Journal*, 39, 1154-1184.
- [10] Shockley-Zalabak, P., Ellis, K., & Winograd, G. (2000). Organizational trust: What it means, why it matters. *Organization Development Journal*, 18(4), 35.
- [11] Baer, J. (2015). The importance of domain-specific expertise in creativity. *Roepers Review*, 37(3), 165-178.
- [12] Andersen, J. A. (2019). Trust in Managers Revisited: Antecedents, Mediating Factors, and Consequences. *Dynamic relationships management journal*, 8(2), 65-73.
- [13] Pučėtaitytė, R., Novelskaitė, A., & Markūnaitė, L. (2015). The mediating role of leadership relationship in building organisational trust on ethical culture of an organisation. *Economics and Sociology*, 11-31.
- [14] Sankowska, A. (2013). Relationships between organizational trust, knowledge transfer, knowledge creation, and firm's innovativeness. *The Learning Organization*, 20(2), 85-100.
- [15] Curşeu, P. L., & Schrujier, S. G. (2010). Does conflict shatter trust or does trust obliterate conflict? Revisiting the relationships between team diversity, conflict, and trust. *Group Dynamics: Theory, Research, and Practice*, 14(1), 66-79.
- [16] Porter, L. W., Crampon, W. J., & Smith, F. J. (1976). Organizational commitment and managerial turnover: A longitudinal study. *Organizational behavior and human performance*, 15(1), 87-98.
- [17] Avolio, B. J., Zhu, W., Koh, W., & Bhatia, P. (2004). Transformational leadership and organizational commitment: Mediating role of psychological empowerment and moderating role of structural distance. *Journal of Organizational Behavior: The International Journal of Industrial, Occupational and Organizational Psychology and Behavior*, 25(8), 951-968.
- [18] Xiong, K., Lin, W., Li, J. C., & Wang, L. (2016). Employee trust in supervisors and affective commitment: The moderating role of authentic leadership. *Psychological reports*, 118(3), 829-848.
- [19] Janssen, O. (2000). Job demands, perceptions of effort - reward fairness and innovative work behaviour. *Journal of Occupational and organizational psychology*, 73(3), 287-302.
- [20] Luo, Y., Cao, Z., Yin, L., Zhang, H., & Wang, Z. (2018). Relationship between extraversion and employees' innovative behavior and moderating effect of organizational innovative climate. *NeuroQuantology*, 16(6), 186-194.
- [21] Afsar, B., Badir, Y. F., & Saeed, B. B. (2014). Transformational leadership and innovative work behavior. *Industrial Management & Data Systems*, 114(8), 1270-1300.
- [22] Graen, G. B., & Uhl-Bien, M. (1995). Relationship-based approach to leadership: Development of leader-member exchange (LMX) theory of leadership over 25 years: Applying a multi-level multi-domain perspective. *The leadership quarterly*, 6(2), 219-247.
- [23] Koys, D. J., & DeCotiis, T. A. (1991). Inductive measures of psychological climate. *Human relations*, 44(3), 265-285.
- [24] Huff, L., & Kelley, L. (2003). Levels of organizational trust in individualist versus collectivist societies: A seven-nation study. *Organization science*, 14(1), 81-90.
- [25] Porter, L. W., Steers, R. M., Mowday, R. T., & Boulian, P. V. (1974). Organizational commitment, job satisfaction, and turnover among psychiatric technicians. *Journal of applied psychology*, 59(5), 603.
- [26] De Jong, J., & Den Hartog, D. (2010). Measuring innovative work behaviour. *Creativity and innovation management*, 19(1), 23-36.
- [27] Brislin, R. W. (1980). Cross-cultural research methods. In *Environment and culture* (pp. 47-82). Springer, Boston, MA.
- [28] Ringle, Christian M., Wende, Sven, & Becker, Jan-Michael. (2022). *SmartPLS 4. Boenningstedt: SmartPLS*. Retrieved from <https://www.smartpls.com>.
- [29] Henseler, J., Ringle, C. M., & Sinkovics, R. R. (2009). The use of partial least squares path modeling in international marketing. In *New challenges to international marketing*. Emerald Group Publishing Limited.
- [30] Hair, J. F., Sarstedt, M., Ringle, C. M., & Gudergan, S. P. (2018). *Advanced Issues in Partial Least Squares Structural Equation Modeling (PLS-SEM)*. Thousand Oaks, CA, Sage.
- [31] Hair Jr, J. F., Hult, G. T. M., Ringle, C. M., & Sarstedt, M. (2021). *A primer on partial least squares structural equation modeling (PLS-SEM)*. Sage publications.
- [32] Henseler, J., Ringle, C. M., & Sarstedt, M. (2016). Testing measurement invariance of composites using partial least squares. *International marketing review*.
- [33] Hair, J.F. Risher, J.J. Sarstedt, M. Ringle, C.M. (2019). When to Use and How to Report the Results of PLS-SEM. *European Business Review*, 31(1), 2-24.
- [34] Hofstede Insights (2022). *Country comparison: Serbia vs. Slovenia*. Retrieved November 1, 2022, from <https://www.hofstede-insights.com/country-comparison/serbia,slovenia/>.
- [35] Sapsford, R., & Abbott, P. (2006). Trust, confidence and social environment in post-communist societies. *Communist and Post-Communist Studies*, 39(1), 59-71.
- [36] Yu, M. C., Mai, Q., Tsai, S. B., & Dai, Y. (2018). An empirical study on the organizational trust, employee-organization relationship and innovative behavior from the integrated perspective of social exchange and organizational sustainability. *Sustainability*, 10(3), 864.

# Problems of Quantitative Measurement Technological Level of the Economy

Oleg Sukharev<sup>1</sup>

<sup>1</sup>Institute of Economics of the Russian Academy of Sciences, Moscow, Russia

<sup>1</sup>o\_sukharev@list.ru

*Abstract*—The purpose of the research is to identify the main problems of measuring the technological level of the economy. The methodology consists of the theory of technological development and measurements, statistical estimates. The result boils down to an assessment of the manufacturability by types of economic activity by gross value added, and the ratio of innovative and non-innovative products, which in general does not give a true idea of the level of technological development of the economy. A change in the method of technology accounting by the method of technological maps is proposed, an assessment of the sensitivity of the level of manufacturability to investments in old and new technologies, with reference to the created classification of technology types by types of economic activity.

**Keywords** - technologies, R&D costs, innovative and non-innovative products, economic growth, investment

## I. INTRODUCTION

The technological level of the economy is determined by the existing structure of technologies used at various levels [1-3].

The structural problem is expressed in the fact that the professional structure of the economy affects economic growth, that is, each professional group makes its own contribution to it. Various technologies also provide their impact on economic growth. Old technologies, contrary to the accepted opinion, can make a very significant contribution to the growth rate in some areas of development, but new technologies can even slow it down. Of interest is the assessment of the professional group that

makes the greatest contribution to the growth rate, as well as the type of technology that provides the same result. The solution of such structural tasks will allow us to approach the justification of strategic decisions not only in the field of science and education, or high technologies and knowledge-intensive sectors, personnel training, but also the management model of economic growth [4-7].

The above makes it possible to formulate the task of measuring the technological level of the economy as a starting point in conducting the necessary studies of the impact of technological development on growth and reverse effects. The purpose of the study is to analyze the problems of measuring the technological level that have accumulated in modern accounting and measurement practice carried out by statistical offices in different countries, in particular, in Russia. The methodology consists of approaches in the field of measurement theory of technological development and growth [6,7]. To achieve this goal, we will consider what the technological level of the economy is and in what ways it can be measured.

## II. CUMULATIVE EFFECT OF ECONOMIC POLICY AND ITS REFLECTION IN THE CHANGE OF TECHNOLOGICAL LEVEL

Controlling influences are very difficult to investigate, since the study is subject to a period of time already lived. Policy and management can have a cumulative effect – negative or positive, when, in the first case, the sensitivity of the economy decreases to measures of influence, in the second – it persists or increases. It becomes a non-trivial task of

modern management and economic science to determine which instruments have what cumulative effect. It is impossible to change the management methods already applied, as well as to assume that their repeated application will give the same effect after a certain time (although there is a certain probability of this). This circumstance dictates the need to have an idea of the cumulative effect of the policy. The technological level of the economy is also differently sensitive to investments in new and old (obsolete) technologies. Therefore, in this area, in relation to investment policy, there may also be a cumulative effect of its influence on the technological structure.

The negative cumulative effect limits the possibility of prolongation of the application of certain policy measures. The degree of sensitivity of the system elements and its overall control tools can change quite quickly. From the point of view of macro-management, it is assumed that individual parameters and connections will remain unchanged for some next period of time. This allows us to consider the identified reactions of the system for the previous time interval, persisting in the near future. As a result, the instruments of macroeconomic policy (management) are formed based on very erroneous economic policy settings. The higher the uncertainty of a system element, for example, technology, the more mistakes can be made. They are caused by the peculiarities of changing the impact of technology on economic development, the assessment of the technological level of the system and the selection of methods for managing technological changes. Let us consider in detail the problem of measuring the technological level, because it will largely determine then the management.

### III. TECHNOLOGICAL LEVEL OF THE ECONOMY AND ITS MEASUREMENT

The technological level of the economy is a characteristic of its manufacturability, that is, how exactly this system uses all kinds of resources to obtain a full set of benefits (products and services), the performance of necessary functions. In other words, it reflects what kind of effectiveness the system provides

in some way, transforming resources into useful benefits and functions, including management. The assessment of this level can be carried out in different ways, but it should provide information on how effectively the method of influence is applied to various objects. This level is relative, but the criterion for its assessment for an adequate comparison should be equivalent and reflect the degree of application of new technologies that reproduce the effect of savings.

The impacts in the form of decisions taken affect both the level of technology and the dynamics of various economic structures, the closeness of connections between them. The need to measure the strength and causes of this influence on the elements of the economy represents the meaning and content of the task of "structural management". The level of manufacturability can be measured by the ratio of investments in new and old technologies. With the dominance of the former, the process of technological renewal is more intensive. Investments in new technologies can be considered as the costs of technological innovations of organizations. Investments in old technologies are defined as the difference between the gross accumulation of fixed capital and investments in new technologies, since what does not go to new technologies serves the old technological basis.

The structure of investments can change in various ways:

1. the value of total investments is growing, but the ratio of investments in new and old technologies does not change;
2. the amount of investments is growing, but the ratio of investments is changing towards either new or old technologies;
3. the total amount of investments does not change, but the ratio of investments changes, either in favor of old or new technologies, or does not change.

It is possible that the amount of investment is reduced, and the ratio of investments in new and old technologies does not change, or may change in favor of a certain type of technology.

The contribution to the growth rate of old and new technologies can be estimated by investments in these technologies, as one of the ways. In addition, it can be done by the amount of added value created on old and new technologies, although it is often not possible to separate the latter.

The technological level of the economy can be measured in various ways.

Firstly, today in Russia, for example, the assessment of manufacturability is applied by the amount of R&D costs in the total amount of added value created. Based on this, Rosstat identifies high-tech activities, two subspecies of medium-tech activities, as well as low-tech activities. Moreover, the grouping of activities according to OKVED related to one or another type is carried out. This approach is very inaccurate, since there is no direct correlation between the amount of R&D costs as a proportion of a certain amount, for example, value added, and technological efficiency. Low costs can be spent on those R&D that will give a large contribution in the field of creating new technologies, and large costs can be associated with R&D that do not give a significant ‘technological result’ at all, but in the form of a report are gathering dust on the shelves of the organizations that carry them out.

Secondly, the technological level can be assessed by the number of advanced technologies used from their total number, or by the amount of innovative products in the volume of non-innovative, or by the amount of gross value added created by new technologies to the total value of this indicator.

However, this method of evaluation also has inherent disadvantages, since it depends on how technological innovations are taken into account, or advanced technologies are relatively not advanced. In addition, it is often not possible to allocate the added value created using the latest technologies, since both advanced and outdated technologies are involved in the creation of products. At the same time, this method is direct, in contrast to the indirect assessment of R&D, which are not directly responsible for the emergence of new technologies.

#### IV. RESULTS DISCUSSION

Here is the definition of various types of activities that create gross value added,

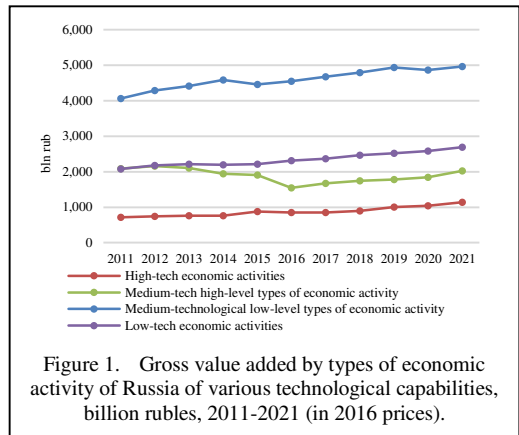

Figure 1. Gross value added by types of economic activity of Russia of various technological capabilities, billion rubles, 2011-2021 (in 2016 prices).

according to the level of manufacturability, based on the methodology of Rosstat. As it was noted, the criterion for classifying high-tech activities is the amount of R&D costs in the total amount of value added, and the criterion for knowledge-intensive activities is the share of persons with a high level of professional education in the number of employees. In conditions of greater coverage of people with higher education, the latter assessment is also highly imperfect. This was clearly shown by the author on the example of the Eurostat methodology of accounting for the “knowledge economy”.

Note that from the recession of 2014 onwards, Russia's technological level, measured in relation to innovative to non-innovative goods, works and services, has generally declined (Fig.1). A slight increase was observed only in 2016, and then in 2019-2020, which did not bring the total value significantly higher than 2011.

Thus, in order to ensure sound management of technological development, it is necessary not only to more accurately and adequately measure the technological level of the economy, including regions, but also to study the causes and factors of a particular regime of its dynamics. The rating approach is in many senses very flawed and not suitable for obtaining plausible estimates that are necessary for building an economic policy that stimulates technological development.

#### V. CONCLUSION

In conclusion, we note the following conclusions.

Firstly, the measurement of the technological level of the economy today is

very imperfect. The reason is the presence of objective difficulties in interpreting this level, as well as a set of accounting and measurement limitations.

Secondly, the applied estimates can greatly affect management decision-making, the implementation of mathematical models that will lead away from reality, including, I mean, assessments of the “knowledge economy”, the activities of intellectual firms and etc.

Based on the identified limitations, it is necessary to increase analytical efforts to improve the criteria of manufacturability, their measurement, statistical accounting and interpretation of models and applied empirical analysis. This report takes a step in that direction. It will be necessary to assess the sensitivity of various technologies and the overall level of manufacturability to various types of investments in technology, as well as the compilation of technological maps as a way to identify the technological level of this type of activity.

## REFERENCES

- [1] Sukharev, O. S. (2016). *Theory of economic restructuring*. Moscow Lenand.
- [2] Aghion P., & Howitt, P. (2007). Thoughts on Capital Accumulation, Innovation, and Growth. *Annals of Economics and Statistics*, 125-126, 57-78.
- [3] Vo, L.V., & Le, H.T.T. (2017). Strategic growth option, uncertainty, and R&D investment. *International Review of Financial Analysis*, 51, 16-24.
- [4] Iamsiraroj, S. (2016). The foreign direct investment–economic growth nexus. *International Review of Economics & Finance*, 42, 116-133.
- [5] Gabardo, F.A., Pereira, J.B., & Einloft, P. (2017). The incorporation of structural change into growth theory: A historical appraisal. *Economía*, 18(3), 392-410.
- [6] Sukharev, O. S. (2022). Intellectual Firm: Key Features and Development Models. *Journal of Knowledge Economy*.
- [7] Sukharev, O. S. (2021). Modern characteristics of knowledge firms. *3-rd Virtual International Conference PaKSoM 21. Complex system research Center*. Mathematical Institute of the Serbian Academy of Sciences and Arts (pp. 139-145).

# Competencies for the Knowledge Economy and Reducing Unemployment

Milica Stanković<sup>1</sup>, Tiana Anđelković<sup>2</sup>

<sup>1,2</sup>The Academy of Applied Technical and Preschool Studies, Vranje, Serbia

<sup>1</sup>milica.stankovic@akademijanis.edu.rs, <sup>2</sup>tiana.andjelkovic-vr@akademijanis.edu.rs

**Abstract**—Unemployment is an extremely challenging topic that many economies face. The fact that there are more than 200 million unemployed today is devastating. At the same time, the majority of the unemployed are young people, women, minorities, and people with disabilities. In this situation, they turnover to the gray economy, and “work illegally”. Unemployment is a huge cost for the state, but also for the individual and his family, so the state should fight against it with various measures and policies. The fact that only a small variety of young people possess the necessary knowledge and skills necessary for modern business also speaks in favor of unemployment. Young people do not have enough IT knowledge, they don’t know how to navigate, they work under pressure, they do not have developed logical and communication skills. That is why it is necessary to pay special attention to both the reform of traditional school system and the encouragement of non-formal and informal education of young people. Only in that way there will be an increase in the number of employed people, and young people using the acquired knowledge and skills will directly influence the productivity and efficiency of the company, and thus economic growth. The aim of this paper is to point out the importance of knowledge, skills, as intellectual capital in the modern economy.

**Keywords** - knowledge, competences, unemployment, youth, economy

## I. INTRODUCTION

The potential or real loss of a job is probably even more difficult than the inability to employ young people. It is a risk faced by all employees who may lose their job for some reason. Losing a job is not only disastrous for the individual

because he is left without a regular income and potentially falls into depression because of it [1]. The loss of a job also means an increase in the state's costs because it must pay unemployment insurance to the dismissed worker. The loss is for various types of markets because the demand for some products will decrease. It is also a loss for the financial sector because they will be laid off without the ability to pay loan installments or pay insurance premiums. Therefore, the loss is not only at the level of the individual but is multiplied. It's the same with unemployment. An unemployed young person costs not only his parents, but also the state and other market participants.

We live in the age of information and communication technologies, where information is the main resource, and the skills that are valued in those conditions are the ability to analyze that data, teamwork, and exceptional communication skills. Manual work, which involves performing the same operation, is no longer so prevalent even in mass production. Employees are increasingly expected to use logic, to be able to use the knowledge and information they possess as a resource to achieve the company's goals. We live in an era of digital economy with a focus on knowledge, it is necessary that individuals have a constant desire to expand their knowledge and skills. But considering that it is an expensive process, they need to have the support of the state and other institutions to reduce the burden that the unemployed leave on the entire economy.

Skills and abilities are a very important element that decides in which workplace someone will be employed. Withdrawal,

resource lessness, walking the line of least resistance and giving in to the situation are long gone. A person needs to work on himself continuously, to acquire new skills and new knowledge so that he, as an individual, can be competitive on the labor market. Unlike the socialist period where people got a job after finishing school and usually stayed in the same company until retirement, today it is a real rarity. Regardless of whether someone is employed or not, he should work continuously on acquiring new knowledge and skills, to maintain his current position, possibly advance in the same company or improve his position for a future engagement.

The aim of this paper is to point out the importance of knowledge, skills and intellectual capital in the modern economy. Extremely important topics such as unemployment, but also the possession of skills needed in modern business will be covered. In the paper, the methods of induction and deduction, as well as the descriptive method, were used. The first part of the paper will be devoted to the knowledge-based economy and the influence of the human factor on economic variables such as productivity and efficiency. The second part of the paper will discuss the skills that individuals should possess in order to be recognized on the labor market and find a job in the shortest possible time. The third part of the paper talks about unemployment as a limiting factor of economic growth. After a comprehensive analysis, relevant conclusions and recommendations are given.

## II. KNOWLEDGE ECONOMY - IMPACT ON ECONOMIC VARIABLES

The economy based on knowledge has its own development path since the 70s of the last century until today. It gradually developed and was implemented in different economies in parallel with the development of information and communication technologies, and even then, there was a division of employed and unemployed individuals into those who follow trends and improve and those who are afraid of them. All this leads to the separation of business ethics from ethics as a scientific discipline, because in addition to other ethical issues, the number of ethical problems that arise when firing and hiring people is also increasing. It's true, profit is not in every case ahead of ethical principles, but for a company to survive from period to period in turbulent and dynamic business conditions, it is increasingly necessary

to monitor changes in the market and react to them. And that was made possible only by knowledge, that is, an economy based on knowledge.

The term knowledge-based economy derives from the understanding of the importance of knowledge and technology for economic growth. Knowledge is immanent to human beings and in the literature, we find it as intellectual capital, human capital, therefore, in technological progress, knowledge has always been of exceptional importance for economic growth [2]. In the last twenty years, the increasing importance of the human factor has been noticed both for developed economies and for developing economies, especially in sectors such as electronics, aviation, computing. The service sector also shows an increasing dependence on people's knowledge and skills, so that the information and communication sector is growing even faster. Back in the nineties of the 20th century, it was estimated that more than half of the gross domestic product (GDP) of developed countries comes from knowledge.

All this tells us that knowledge has become the main source of innovation and growth [3]. Economic growth of any country is impossible without innovation and entrepreneurial spirit. Entrepreneurial spirit implies the knowledge of many skills, knowledge, and abilities that individuals must possess if they want to stand out from the crowd and start working more efficiently and be more competitive. People who fit the criteria of the knowledge economy are not born that way. They develop these skills throughout their lives. At the end of their formal education, they continue to learn and have a constant desire for new knowledge, which they could apply in practice and thus perform better than the competition. That is why the importance of learning and knowledge should be constantly emphasized among young people, because only in this way they will be an adequate staff that will be desired in many organizations. However, continuous work should also be done to improve the educational process, where young people would be introduced to the trends that exist in various economic activities while still in school. They should be able to do professional practice in different companies, to see how things, work in the economy and to work on the skills they need to develop or improve in time. In Europe, the dual education model has been increasingly exploited in recent decades, which developing countries are slowly starting to apply. The dual

model of education implies the practical application of theoretical knowledge acquired in the process of formal education.

One of the main reasons why companies are increasingly dealing with employment policy is that not everyone is able to influence the productivity growth of that company in the same way. Employees who have more developed skills, who think logically, are flexible, can better organize their working time, are communicative, will produce a larger volume of products more easily and quickly, unlike the average individual. However, not all people are so adaptable, and they cannot achieve the given goals, but they can be placed in those positions that will correspond to their abilities. Many studies mention the connection between productivity growth and information and communication trends [4]. In those studies, interpretations were given for the productivity trend. In the case of technical-technological progress, a drop in productivity is usually noted first, and economists believe that the reasons are different - from the situation that the company had insufficient capital investments to maintain that productivity growth, through the drop in innovation, which consequently affected the drop in productivity, increased prices of raw materials and technologies, government regulation, and even workers' skills and abilities have deteriorated or workers may not want to work as hard as before.

The conclusion is that productivity growth is influenced by technological changes. However, productivity is a broader term than technological changes, because in addition to technological changes, we must also consider the human factor here. Better managerial skills in terms of managing both production and workers can affect the growth of production, i.e., the reduction of costs, and all this together affects the level of productivity. However, it is not always feasible to separate technological factors from sociological ones, so all options must be carefully considered before a final decision is made.

Today, the role of a manager cannot be reduced only to reacting in case something unforeseen happens. His role is to manage risk in such a way that he can predict what will happen. This means that the manager, based on his previous experience and the experience of similar companies, predicts what the company can potentially expect in the future. For this purpose, it is necessary to develop such

competences, which will enable the company to deal with its uncertainty, which the market carries by itself. They imply that company managers as well as employees present a certain minimum of technical knowledge and experience in order to predict in time the trends that innovations and crises bring.

### III. SKILLS AND ABILITIES ESSENTIAL FOR THE EMPLOYMENT OF A MODERN MAN

Education and training of the individual is a key element of the knowledge-based economy. It is these variables that make it easier for people to find work, while on the other hand, investing in them brings long-term income, and therefore peace and security for the individual [5].

People acquire knowledge and skills throughout their lives. However, when they reach a certain age, in addition to formal education, they must acquire such knowledge, competences and attitudes that will help them find a job and keep it, which means that they will have developed skills such as flexibility, adaptability, communication, the ability to work in a team, knowledge of information and communication technologies and others, to deal with market dynamics. At the end of formal education, everyone expects to get a job right away, but this is mostly not possible.

Given that these are mostly young people looking for their first job, in addition to formal education, it is very important to pay attention to informal and non-formal education as well [6]. People acquire informal education every day - at work, in the family or during their free time. This education is experiential and as such does not result in any certificates or diplomas [7]. Non-formal education is not provided by educational institutions such as colleges and universities, and it often does not award any degrees or certificates. However, here we are talking about the desired - deliberate learning of new knowledge and skills, and this requires additional time and effort from the participants, to acquire the desired abilities. Non-formal education is a term that describes a wide range of learning that provides learners with the opportunity to acquire new skills that will benefit them at work or in life.

The European Union has been implementing an active employment policy for many years, and thus supports the reintegration of the unemployed into the labor market. The importance of skills in successfully finding a job



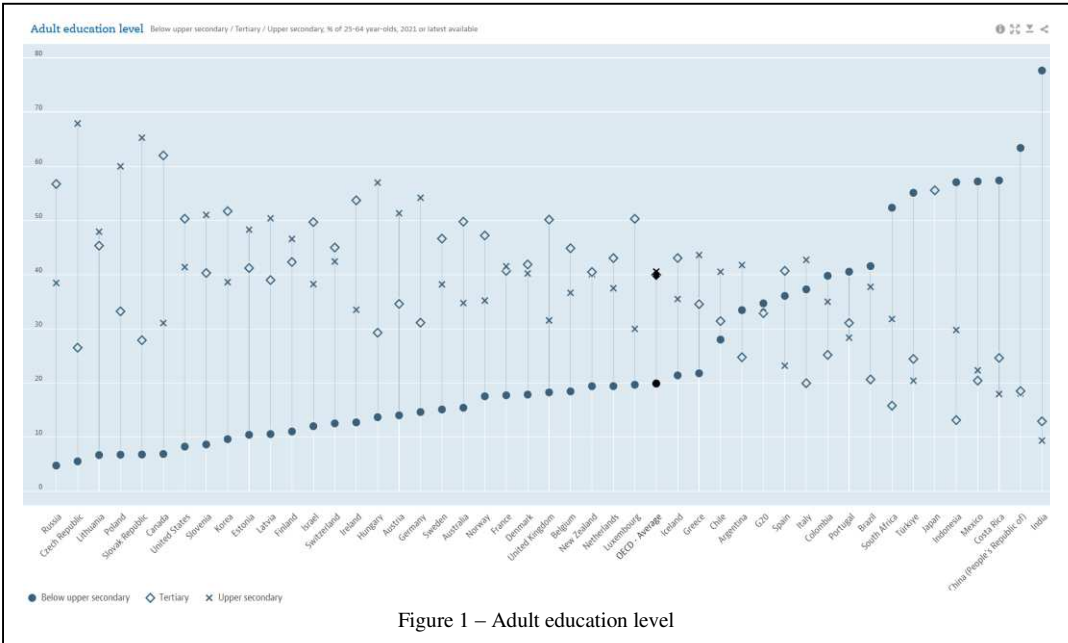

Figure 1 – Adult education level

is increasingly being understood. As for the unemployed, there are several ways to improve their skills - learning on the job as part of training, subsidizing temporary jobs [8]. Such a way of acquiring skills is intended for all levels of education of people - from low-educated to highly educated. The European Union defines the key competencies that should exist for employees within the territory of the European Union. However, not all member states use the

same terminology, so they call the same competencies by similar names [9].

Given that basic skills such as reading, writing, and knowledge of mathematics acquired through formal education are no longer sufficient for working in any position, the need to redefine the model of formal education is increasingly highlighted [10]. As it is a very difficult process, more and more often individuals and companies are turning to processes of retraining or retraining

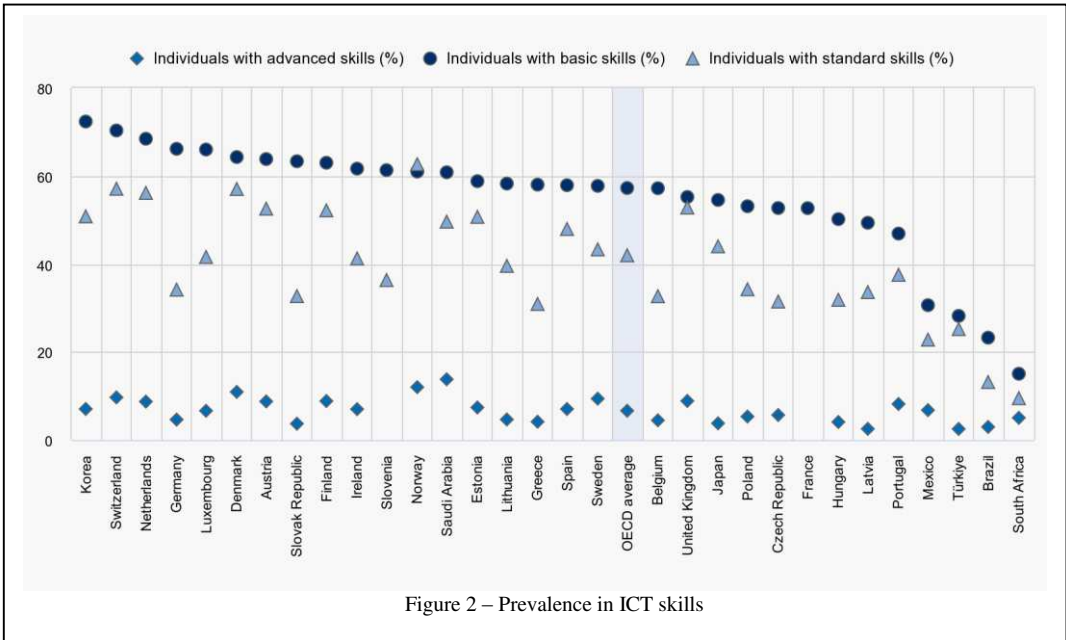

Figure 2 – Prevalence in ICT skills

of workers. Those processes have a significant impact on the structure of the employees as well as the performance of the company. The greatest impact of these changes is reflected in the OECD countries, where there is an increasing supply and demand for highly educated people on the labor market.

This concept of “knowledge-based economy” is based on the fact that information and knowledge are the main driver of economic growth and development. This ability to obtain and use information in a timely manner is a vital source of skills for many [11]. Many changes in information and communication technologies, the innovations that followed, could not be accompanied without adequate intellectual capital. Industries whose growth is based on knowledge - manufacturers of high-tech goods, but also other sectors that make extensive use of modern technologies (banking, insurance, communications...) make up more than half of the gross domestic product of OECD countries and are growing rapidly. In the continuation of the text, we will see a graph that shows the educational structure of the population in various world economies that were the subject of OECD analysis [12]. This is a very significant piece of information that indicates how far these economies have progressed in understanding the importance of intellectual capital for the economic development of those countries.

As we can see in these graphs, the awareness of the importance of intellectual capital and skills exists in most countries, but in most of them, the knowledge-based economy has not yet shone in its full glory. The most common problem that is observed is the lack of knowledge about information and communication technologies (ICT), therefore there is a general lack of ICT skills.

This deficiency hinders the use of available digital technologies and is not in accordance with the goals of sustainable long-term development. The research on the knowledge of information and communication technologies, which was conducted by the OECD according to the ITU (International Telecommunication Union) methodology, was conducted by having employees in some companies answer questions such as whether they use ICT in their work, the availability of Internet access, whether use of ICT skills the same if the job description changes, how long it takes them to do a job using ICT skills, have they used this skill recently.

Then, based on these answers, the respondents were divided into three groups - possessing basic, standard and advanced ICT skills. Basic ICT skills would include working with files, files, sending emails. Standard ICT skills would be working with spreadsheets, presentations, installing software, while advanced ICT skills would be the ability to program or code. On average, about 55% of respondents have developed basic ICT skills. In Switzerland or Korea, that percentage is around 70%, in contrast to Brazil, where it is less than 30%. In contrast, only 7% of respondents said they knew advanced ICT skills in developed countries, compared to less than 3% in underdeveloped economies.

The same survey showed that adults with higher education have a higher rate of participation in non-formal education and training than those with less education. All this speaks in favor of the enlightenment that people with higher education possess and which they acquire precisely through that higher formal education.

#### IV. REDUCING UNEMPLOYMENT - TREND OR REALITY?

Unemployment is a serious problem of every economy. If it occurs at the beginning of an individual's working life, it can lead to serious consequences. In a young person, this can be manifested through a loss of self-confidence, a loss of the opportunity to acquire experiential skills that can only be acquired through work, and then there is a whole series of negative economic facts - lower income per member of that family, decrease in demand due to decreased income, decrease in sales, reducing the amount of tax that sellers pay for sold goods, and in addition to this negative effect on the state, there is at least one more, which is an increase in social benefits to encourage consumption.

Unemployment is not a phase that exists between schooling and finally finding a job. It is a very difficult and long-term process where young people go from finishing school through volunteering, low-paid unqualified employment or illegal employment to employment that suits the individual according to his knowledge and competences. All elements of this process are reflected through the large informality of the labor market, the growing gap between skills and earnings, and the decline in the income of informal workers [13].

As for the problem of unemployment in the last few years, large fluctuations have been recorded, mostly due to the pandemic caused by the COVID-19 virus. According to the ILO report from 2020, which refers to the period up to December 31, 2019. In 2018, we see that the general decline in youth engagement in the labor market continued because young people devoted more time to their formal education [14]. On the one hand, this may have indicated the possibility for young people to better devote themselves to the development of skills that are not acquired in the workplace, but on the other hand, it led to underutilization of the workforce. Other problems associated with youth unemployment are the dominance of informal employment, the lack of gender equality, and the youth's lack of work experience. The fact that millions of young people would gladly emigrate if they had the opportunity to work somewhere abroad for a job for which they have the skills but for higher earnings is also very important. 2019 was followed by 2020, with the pandemic caused by the COVID-19 virus and this led to an even greater decrease in the demand for labor. Worldwide, during 2020, the number of working hours decreased by as much as 8.8%, and this trend continued in 2021, by 4.8% in the first quarter and 4.4% in the second quarter of 2021 [15]. Therefore, economic policy measures did not allow people to lose their jobs during the pandemic, so most of them kept their jobs but worked with reduced hours or did not work at all, while some still lost their jobs.

If, however, we only observe the period before the emergence of the COVID-19 virus, we will see a growing trend in the participation of employees with secondary or higher education compared to the period at the end of the 20th century. All of this points to the fact that people also understood the importance of knowledge, so they completed school to a greater extent, in order to have better qualifications [16]. The unemployment curve was decreasing in developed countries in this period thanks to the reduction of the informality of the labor market, reduced gender discrimination of the unemployed, while in developing countries, the informal labor market still functioned in addition to the formal one, with pronounced discrimination against women and minorities.

Even one of the sustainable development goals (Sustainable Development Goal) under number 8 states that it is necessary to promote sustainable and inclusive economic growth, full

and productive employment, and decent work for all [17]. Unfortunately, this goal requires GDP growth of at least 7% per year, while the least developed countries still have annual GDP growth of 5% or less. Sustainable development should be achieved through optimizing the efficiency of resources in production and consumption, through increasing labor productivity, through fostering innovation and formalizing the labor market. The very fact that in most countries many farmers still work without applying for mandatory social insurance tells us that we are still far from achieving this goal globally. The global unemployment rate in 2022 is expected to be 5.7% with about 207 million unemployed people in the world [18], in contrast to about 170 million people who were unemployed in 2018 [16]. Among the unemployed, women, young people, people with disabilities, minorities who do not acquire skills that are valued in the labor market are at the forefront, and this all reduces their chances of employment. As far as employees are concerned, in most countries there is a difference in wages between men and women ranging from 10 to 25%, which shows that we are still far from the requirement for equal work to be paid equally.

Preparation for the future working life of everyone implies that everyone is continuously exposed to the situations they will encounter at work, but also to the knowledge of how knowledge and skills develop in those positions [19]. The goal of governments should be to rebalance the economy through strategies to increase investment and through new education and training policies. Therefore, governments are trying to establish a balance between the process and the outcome - it is necessary to improve education, qualifications, the system of professional training, industry, entrepreneurship, implementation of various campaigns in the field of gender equality, all in order to establish a balance on the labor market [20]. All these processes would be improved with the help of the use of public-private partnership, the implementation of internships and internships, all with the aim of developing knowledge and skills and employment of young people and advancement in business.

## V. CONCLUSION

Considering everything that was discussed, the conclusion is that we should work as much as possible on the process of formalizing the labor

market, equalizing the rights of men and women and including young people, people with disabilities and minorities in companies so that they can use their knowledge and skills and contribute to the efficiency of business those companies, and on the other hand acquired the skills necessary to advance in life and work. Unemployment is a huge problem facing the whole world, but we all must be aware that it is a phenomenon that is negative for the global economy because it affects the reduction of social welfare.

Today's problem is certainly the desire to quickly find a job. In the short term this is fine, however such a way of employment results in an inadequate workplace for that individual in the medium and long term because there is often no matching of his skills with the job description. That should be the task of the states in the future - to deal with the issues of matching skills and available jobs. In this way, people's skills and abilities are put before other factors and everyone should be assigned to a workplace according to their competencies.

It is obvious that the knowledge-based economy is changing the demands on the labor market in terms of supply and demand. This is also evidenced by the large number of highly educated staff that exist on the labor market around the world, because with the increase in the level of formal education, people's awareness of the importance of knowing the skills that are necessary for successful business also grows. This fact indicates a higher probability that these people will be more open to new knowledge and new skills during their life and work, so they will be more flexible than workers who worked 10, 20 or more years ago.

Bearing in mind all the above, we must not forget the impact of competences and the knowledge-based economy on risk management. We live and work in extremely uncertain conditions and unpredictable things threaten us from minute to minute. In this sense, we need to work on skills such as flexibility and adaptability to know how to manage in new conditions. Innovations that occur in the companies, but also in the global changing environment, bring a number of advantages, but also the uncertainty that we have to face and turn threats into opportunities for the company. Therefore, it is of utmost importance that managers develop knowledge-based competencies in order to effectively manage risk.

## REFERENCES

- [1] Blundell, R., L. Pistaferri, and I. Saporta-Eksten (2012). *Consumption inequality and family labour supply*. National Bureau of Economic Research Working Paper No. 18445.1
- [2] Organisation for Economic Co-operation and Development [OECD]. (1996). *The Knowledge based Economy*, retrieved from Knowledge-based economy.pdf (basicknowledge101.com)
- [3] Schiliro, D. (2012). Knowledge-based economies and the institutional environment. *Theoretical and Practical Research in Economic Fields (TPREF)*, 3(05), 42-50.
- [4] Korres, M., G. (2008). *Technical Change and Economic Growth: Inside the Knowledge Based Economy*. Routledge.
- [5] International Labour Office [ILO]. (2004). *In Focus Programme on Skills, Knowledge and Employability*, Skills Working Paper No. 19, retrieved from: [http://www.ilo.org/wcmsp5/groups/public/@ed\\_emp/@ifp\\_skills/documents/publication/wcms\\_103428.pdf](http://www.ilo.org/wcmsp5/groups/public/@ed_emp/@ifp_skills/documents/publication/wcms_103428.pdf)
- [6] OECD. (2013). *Tackling Long-Term Unemployment Amongst Vulnerable Groups*, retrieved from Tackling Long\_Termunemployment\_WP\_covers.pdf(oecd.org)
- [7] The European Centre for the Development of Vocational Training [Cedefop]. (2011). *Glossary – Quality in Education and Training*, Publications Office of the European Union, Luxembourg
- [8] The European Centre for the Development of Vocational Training [Cedefop]. (2015). *Tackling unemployment while addressing skill mismatch*, Publications Office of the European Union, Luxembourg
- [9] Gordon, J., Halász, G., Krawczyk, M., Leney, T., Michel, A., Pepper, D., ... & Wiśniewski, J. (2009). Key competences in Europe: Opening doors for lifelong learners across the school curriculum and teacher education. *CASE network Reports*, (87).
- [10] Carnevale, A., Gainer, L., Meltzer, A. (1990). *Workplace Basics: The essential skills employers want*, Jossey-Bass, San Francisco.
- [11] OECD. (2001). *Competencies for the Knowledge Economy*, retrieved from 1842070.pdf (oecd.org)
- [12] OECD. (2022). *Education at a glance: Educational attainment and labour-force status*, retrieved from 3197152b-en.pdf (oecd-ilibrary.org)
- [13] Fawcett, C. (2002). *Latin American youth in transition: A policy paper on youth unemployment in Latin America and the Caribbean*, School of International Service, American University, Sustainable Development Department, Social Development Division, Labor Markets Policy Briefs Series, Inter-American Development Bank, p. 1.
- [14] ILO. (2020). *Global Employment Trends for Youth 2020: Technology and the future of jobs*, retrieved from ENG\_ILO\_Report\_GlobalYouthEmployment\_Layout\_InsidePages\_Final.indd
- [15] ILO. (2021). *World Employment and Social Outlook: Trends 2021*, retrieved from: wcms\_795453.pdf (ilo.org)
- [16] ILO (2019): *World Employment and Social Outlook – Trends*, retrieved from World Employment and Social Outlook – Trends 2019 (ilo.org)

- [17] Morton, S., Pencheon, D., & Squires, N. (2017). Sustainable Development Goals (SDGs), and their implementation A national global framework for health, development and equity needs a systems approach at every level. *British medical bulletin*, 1-10.
- [18] Sharma, Y., S., Bureau, E. (2021). *Global unemployment rate will be 5.7% in 2022: ILO*, retrieved from: Global unemployment rate will be 5.7% in 2022: ILO - The Economic Times (indiatimes.com)
- [19] Morris, M., Nelson, J., & Rickinson, M. (1999). *A literature review of young people's attitudes towards education, employment and training*. Great Britain, Department for Education and Employment.
- [20] Hoffman, N. (2011). *Schooling in the workplace: how six of the world's best vocational education systems prepare young people for jobs and life*. Harvard Education Press.

# The Legal Interpretation as a Decision-Making Algorithm

Živorad Rašević<sup>1</sup>, Marko Ćitić<sup>2</sup>

<sup>1</sup>Faculty of Business Economics and Entrepreneurship, Belgrade, Serbia

<sup>2</sup>University of East Sarajevo, Faculty of Philosophy, Department of Mathematics, Pale, Bosnia and Herzegovina

<sup>1</sup>zivorad.rasevic@vspep.edu.rs, <sup>2</sup>citicm@yahoo.com

**Abstract**—This essay explains the structure of legal norms and the process of legal interpretation through the lenses of decision-making theory. It attempts to converge formalistic and realistic theories of judicial decision-making, utilizing the basic methodology developed in the risk management theory. For this purpose, the “hard case” of the justification of human rights restrictions is used as a case study. The process of the application of the law is presented as a cognitive quest for an optimal solution to complicated legal problems. This approach may be useful for rational argumentation, education and the development of artificial intelligence support for the judiciary.

**Keywords** – legal interpretation, decision-making, algorithm, human rights restrictions

## I. INTRODUCTION

There is no doubt that the use of algorithms in digitalized decision-making is a global trend. Legal affairs seem less affected because the hermeneutics of legal texts exceeds the application of rules of logic that are prone to mechanical processing. The legal interpretation must belong to human beings because it involves social prudence and moral intuition. Thus, using pre-programmed algorithms, computerized decision-making, artificial intelligence (AI) and other concepts developed in digital technologies seems to be a highly inappropriate and risky endeavour.

However, the law cannot ignore the contemporary scientific achievements and challenges. To adapt the traditional purpose of the law to the increasingly complicated world,

lawyers should look for ways of exploiting the advantages of new technologies, while being aware of the shortcomings and risks of this quest. In this vein, the algorithms can deliver a logically consistent decision-making framework that enables bias-free information processing. However, this framework must also pay due attention to human considerations of social, philosophical and ethical concerns.

This essay hypothesises that the knowledge gained in the risk management theory can be used to explain the process of legal interpretation through decision-making algorithms that are suitable for computer programming. It implies the crucial role of human beings, and the support of artificial intelligence, which should deliver consistent logic of legal argumentation.

In the following part, the basic concepts of the decision-making theory are explained and applied in the legal context. After that, the structure of legal norms is analysed and adapted to an algorithmic expression. In the last part, the value of algorithmic programming is exposed in “hard cases” of human rights restrictions.

## II. ALGORITHMS, DECISION-MAKING AND THE LAW

Although the concepts that are under consideration hereto permeate, the hypothesis of this essay is eclectic and goes beyond the traditional understanding of law and management. This part attempts to explain these concepts and place them in a persuasive theoretical framework.

Algorithms are sets of rules that describe a process of problem-solving that can be programmed into computers. This possibility underpins the application of AI, which is more than an algorithmic process; It is self-directed and self-adaptive computer activity. Computers enable human beings to solve problems at great speed by processing a huge number of data [1]. Being steps in structural decision-making, algorithms became indispensable heuristic tools in dealing with uncertainties that follow many societal problems and endeavours, such as aircraft collision avoidance, automated driving, breast cancer screening, financial consumption and portfolio allocation, wildfire surveillance, Mars exploration, etc. They are used as methods in programming scenarios, specification of the space of possible decision strategies, maximization of performance measures, planning and learning. "Current state-of-the-art decision-making algorithms rely on a convergence of concepts developed in multiple disciplines, including economics, psychology, neuroscience, computer science, engineering, mathematics and operations research" [2]. Recent research in business shows that algorithms deliver more-efficient and more-equitable outcomes than human beings, who have proven to be inconsistent and biased decision-makers [3,4].

The decision-making analysis utilizes algorithms to facilitate the making of choices between possible alternatives and to calculate influence factors, aiming to develop techniques that lead to better decisions in uncertainties. This discipline defines decision-making as an iterative process that consists of the following steps: (1) identify the decision situation and understand objectives, (2) identify alternatives; (3) decompose and model the problem; (4) choose the best alternative; (5) analyze the suitability of the chosen alternative for the objective (sensitivity analysis). These steps are suitable for quantitative research and computer programming but include personal and subjective judgments. In short, human beings are considered to be imperfect information processors because of cognitive limitations; however, subjective personal judgments remain to be treated as important ingredients of a good decision [5].

The legal literature does not offer a profusion of sources that converge law and decision-making. However, authors that deal with this matter confirm that meanings of the pertinent

concepts permeate and overlap. Tapani Klami explains their propinquity with their purposeful nature: "Legal interpretation is either real or hypothetical decision-making, although is often understood in some other manner... The purpose of the interpretation for the decision-making process of citizens and officials is similar to the purpose of the legislation – to steer decision-making ... I do not see any reason why one could not apply the general decision-making theory to questions of fact as well as questions of law. After all, in both cases, one is speaking about the degree of certainty, i.e., of a more or less justified belief as viewed by the fact finder or interpreter of law." Just like in the decision-making analysis and contrary to the dogma that *Iudex non calculat*, he suggested the use of mathematical models for quantitative calculations in legal interpretation to explain the structure of legal reasoning. [6] In a similar vein, The Justice of the UK Supreme Court Lord Sales stated recently that decision-making algorithms are fundamental to legal thought because the "law itself is a sort of algorithmic discipline: if factors A, B and C are present, then a process of logical steps response Z should occur." He believes that algorithms and AI pose grave threats of depersonalization, illegitimate or inappropriate exercise of power and coded biases. However, they offer huge opportunities in information processing and thus must be used in ways that enhance human capacities, agency and dignity, and not remove them [1].

In the Study prepared by the Committee of Experts on Internet intermediaries of the Council of Europe, it was found that the use of algorithms can potentially have positive and negative impacts on the exercise and enjoyment of human rights. However, algorithms themselves should not be blamed, because the decision-making process around them must be scrutinized. The experts found sufficient reasons for replacing human beings with automated computing systems: "large scale data processing, speed volume and scale of decision-making lower error rates. Data analysis algorithms find correlations within large amounts of data to replicate functions previously performed by human beings and self-learning algorithms generate new decision-making rules through machine-learning techniques." However, the role of a human being is inevitable, because discretion as an important element of decision-making cannot be automated [7].

Finally, there are good examples of the practical application of algorithms in legal proceedings in the USA. First, the bail algorithms are used in the criminal procedure to eliminate bias and improve consistency, utilizing statistical data of the following factors: Age, current charges, criminal history and the record failing to appear of a defendant. But the human agency remains crucial because algorithms do not deliver a perfect solution. They do not cover other important factors, such as his/her employment status, information about substance abuse in his/her past, distinctive facts, and the risk of discrimination against minorities [8]. The second example is the quantitative calculation of the balance between costs of prospective litigation and odds of success that is developed in the economic analysis of legal disputes [9].

In sum, the application of algorithms as tools of legal interpretation is possible only if we reject or at least ignore the stance of legal formalism, i.e. the use of deductive logic to derive a correct decision from premises that are accepted as authoritative. The theoretical ground for this endeavour is underpinned by legal realism, which defines the purpose of interpretation as an outcome that best promotes the public welfare [10]. In this vein, the congruent characteristic of the decision-making and the legal interpretation processes is their result-oriented, purposeful approach to uncertainties in ways, means and ends. This congruence offers sufficient theoretical justification for the application of algorithms as tools of legal interpretation. The algorithmic expression of legal rules might diminish bias, enhance the quality of legal argumentation and be useful in legal education and the prediction of future litigation outcomes. But they lack social and ethical prudence and thus can be only a supportive tool that does not limit judicial powers and diminish judicial discretion.

### III. ALGORITHMS AND THE STRUCTURE OF LEGAL NORMS

Before we investigate the possibility of the application of decision-making algorithms in legal interpretation, we should determine how algorithms can depict the meaning of legal norms. The approach of the traditional legal theory is formal: the logical and semantical structure of legal norms is explained using deductive logic and expressed through syllogism, i.e. the subsumption of the minor

premise under the major premise to draw a conclusion.

In this vein, Kelsen believed that two concepts are sufficient for the understanding of a legal norm: a delict (*D*), i.e. a human behaviour that violates the prescribed narrative in the norm, and a sanction (*S*), i.e. the reaction of a state to such behaviour. These concepts are mutually related into one conditional statement that if somebody behaves in contravention of a legal norm, he/she should be coerced not to do so, to repair or compensate caused harm, etc. [11]. The structure of this deductive discourse can be concisely expressed in the statement:

*If (D) then should (S)*

This statement can be easily translated into the language of decision-making algorithms with flowchart symbols that are usual in computer programming (Fig.1)

The further elaboration leads to the more complicated structure of legal norms that contains ten elements: a conditional situation or primary hypothesis (*CH*<sub>1</sub>); passive person (*PP*); duty (*D*); an object of duty (*OD*); active person (*AP*); right to do/not to do something (*R*); violation or secondary hypothesis (*VH*<sub>2</sub>); a person that should be sanctioned (*S*); duty of the person that should be sanctioned (*DS*); coercion against the person that should be sanctioned (*CS*). These elements are mutually related into one disjunctive structure, consisting of the two hypothesis tests that could be described in the

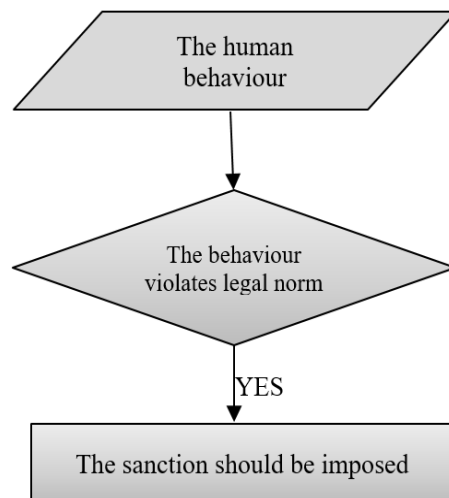

Figure 1. The flowchart of the decision-making algorithm of a legal norm.



following discourse. If the behaviour of a certain person complies with the conditional situation described in a legal norm, that means that this norm recognizes or grants him/her certain legal right and/or imposes a duty. And if this behaviour does not comply with a legal norm, the sanction that is prescribed in this norm should be imposed against that person. This narrative can be summed up in the following statement.

*If (CH1) then should (PP) (D) (OD) and/or (AP) should (A)*  
*Or*  
*If (VH2) then should (S) (DS) (CS) [12].*

The algorithmic form of this statement is given in Fig.2.

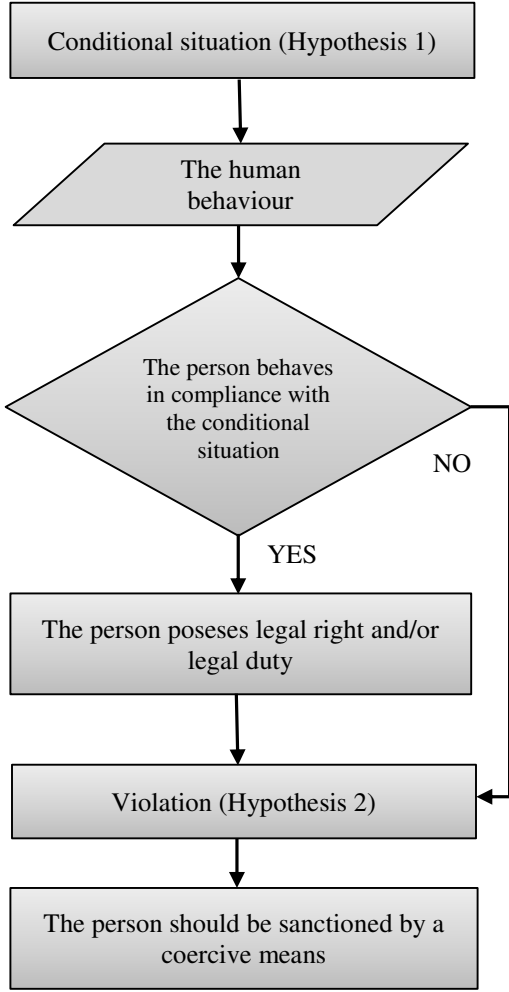

Figure 2. The flowchart based on the hypothetical-disjunctive structure of a legal norm.

These examples prove that the structure of legal norms can be clearly expressed as a set of decision-making algorithms. The value of this approach might be found in legal education and practice because the words are less precise tools. The other advantage of algorithms is their suitability for computer processing of data to an extent that is beyond human abilities and cognizance. On the other hand, such processing must be open to human agency because of the inherent uncertainty in facts that follows every application of the law. However, the main objection to this approach is a deductive formality that neglects the issue of the quality of the outcome. The application of the law is not a leap into the dark; as Ihering concluded a long time ago, it should serve practical motives [13].

IV. ALGORITHMS AND THE LEGAL INTERPRETATION OF “HARD CASES”

In the previous part, simple structures of algorithms depicted the syllogistic structure of legal norms. Their interpretation is a more complex endeavour. Due to the vagueness and ambiguity of legal texts, traditional methods of interpretation (textual, logical, systemic and teleological) cannot be sufficient to solve a practically unlimited number of factual combinations; thus their application produces only random results [14]. And Wendell Holmes Jr. pointed out almost one and a half centuries ago that the life of the law has not been just the logic, but the experience that includes felt necessities of the time, the prevalent moral and political theories, intuitions and even prejudices [15].

In the positivistic legal tradition, hard cases are those in which the applicable norms leave an open door to more than one solution. Sometimes the norms contradict each other in a way that the usual tools of derogation (*lex superior, lex specialis, lex posterior, etc.*) cannot solve this conflict. The only way to solve them is the judicial creation of a new norm after pondering opposite interests [16]. Hard cases are not a rare phenomenon; actually, the application of every legal norm must comply with human rights norms, which are situated at the top of the pyramid of the legal order. In these cases, Dworkin suggests that the competing interpretations fall under judicial discretion to derive the most suitable rule by appraising possible outcomes of applicable means, i.e. legal principles and policies [17,18].

In short, the uncertainties in hard cases interpretation are not just of factual nature, but of legal as well: the interpretation that delivers an optimal result should be chosen among all correct ones, although rules for making such choice are not defined. The multiplicity in legal means and ends is a consequence of uncertainties in facts and law. These uncertainties can be tackled only by the realist result-oriented approach.

The case study for this theoretical finding is the interpretation of human rights restrictions in Articles 8.-11. of the European Convention of Human Rights (ECHR). This is a good example of a “hard case”, for two reasons. First, the ECHR obliges states to reach the result of interpretation that complies or at least optimally corresponds with the enjoyment of pertinent human rights recognized by the ECHR. Second, the reasons for the restriction are prescribed by norms that are not suitable for the application of legal syllogism, because they are not sufficiently structured and precise. They are lacking clear instructions for application and contain several wide and ambiguous notions, such as national security, public safety, economic well-being, public order, health, morals, etc.

The European Court of Human Rights (ECtHR) jurisprudence fills this gap in clarity by developing innovative and evolutionary interpretations. Moreover, these interpretations might be contrary to the intentions of a legislator when legal means or ends are contradictory, obsolete or ambiguous [19]. However, the logical structure of this process always begs for further clarification. In this case, the purpose of the decision-making algorithms is to depict a logically coherent structure that enables computer quantitative data processing and that saves the domain for the social and ethical prudence of human beings.

In this case, McBride constructs the norm that justifies human rights restrictions from the wordings of ECHR, ECtHR jurisprudence and scholars’ interpretations by defining several tests: (1) of the legality of the means that restricts human rights; (2) the pursuit of a legitimate aim; (3) relevant and sufficient reasons for the particular restriction; (4) the proportionality of the means to the expected end, i.e. to the legitimate aim [20]. The last step that should be taken on this pathway is exceptionally complex; the German theory of constitutional law explains it by three consecutive sub-tests of suitability,

necessity and proper balance of the measure with other measures. Alexy defines the last subtest by the quantitative Weight formula for a calculation of the weight of principle  $P_i$  in a concrete case. That is, the concrete weight of  $P_i$  relative to a colliding principle  $P_j$  ( $W_{i,j}$ ), as the quotient, first, of the product of the intensity of the interference with  $P_i$  ( $I_i$ ) and the abstract weight of  $P_i$  ( $W_i$ ) and the degree of reliability of the assumptions concerning what the measure in question means for the non-realization of  $P_i$  ( $R_i$ ), and, second, the product of the corresponding values with respect to  $P_j$ , now related to the realization of  $P_j$  [21]:

$$W_{i,j} = (I_i \cdot W_i \cdot R_i) / (I_j \cdot W_j \cdot R_j) \quad (1)$$

In sum, the whole structure consists of tests that can be expressed in a syllogistic form. The Weight formula introduces quantitative methodology in the legal interpretation of proportionality. This is not surprising because multi-criteria decision-making theory developed many mathematical models to determine the numerical weights of incommensurable values that should be input in such equations [22].

After careful consideration of systemic and logical relations among these tests, the sketch of the path that leads to the optimal choice between applicable legal means that justifies a human right’s restriction is given in Fig.3, and its expression in the Python programming language in Fig.4. The presented flowchart is designed in a way that the negative answer in every step returns the whole discourse to the start, i.e. the new choice of another legal means that are tested again and again until an optimal interpretation is found. In other words, the sum of affirmative answers results in the justification of the human rights restriction [23].

This flowchart is just a sketch that begs completion and further refinement but still offers useful insights. When we compare its content with the description of the decision-making process described in Part II, we can perceive four staggering congruencies. First, as already concluded in Part II, both processes are creative and designed to look for an optimal result in uncertainties. Second, the process of legal interpretation proves to be as iterative and consecutive as the decision-making process: it is based on the sequences of decision-making algorithms that repeat to identify a means that delivers optimal end-state. Third, the sequence of algorithms in both processes is quite similar: the

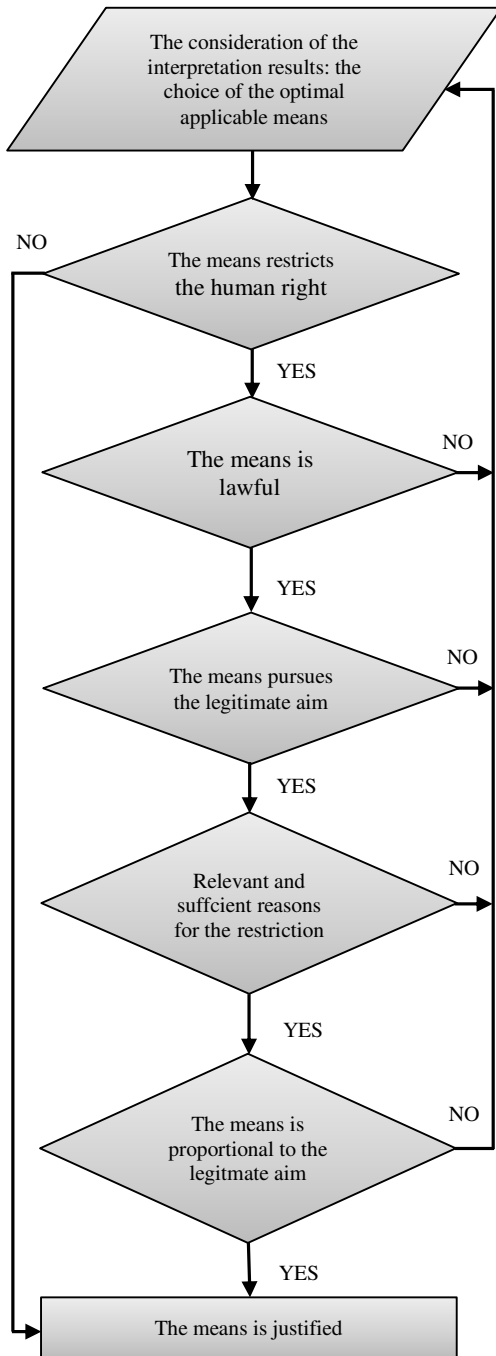

Figure 3. The flowchart of the decision-making algorithms in the interpretation of human rights restrictions

```

def run_def():

    first_message = "THE CONSIDERATION OF THE INTERPRETATION RESULTS: " \
        "THE CHOICE OF THE OPTIMAL APPLICABLE MEANS. Answer Yes or No."
    print(
        "*****"
        "*****"
    )
    print(first_message)
    print(
        "*****"
        "*****"
    )

    first_choice = input("1. The means restricts the human right?").lower()

    if first_choice == "yes":
        second_choice = input("2. The means is lawful?").lower()
        if second_choice == "yes":
            third_choice = input("3. The means pursues the legitimate aim?").lower()
            if third_choice == "yes":
                fourth_choice = input("4. Relevant and sufficient reasons for the restriction?").lower()
                if fourth_choice == "yes":
                    fifth_choice = input("5. The means is proportional to the legitimate aim?").lower()
                    if fifth_choice == "yes":
                        print("The means is justified!")
                    else:
                        run_def()
                else:
                    run_def()
            else:
                run_def()
        else:
            run_def()
    else:
        run_def()

run_def()
  
```

Figure 4. The sketch of the interpretation of human rights restrictions in Python

processes start with the identification of alternative means and ends, continue with the analysis of all alternative means and results of their application, and finalise with their comparison and the choice of an optimal one. Fourth, both processes are designed to be suitable for quantitative calculations and AI and to include human prudence in the appraisal of facts and applicable rules.

## V. CONCLUSION

The findings of this essay prove that decision-making algorithms can be used to explain the structure of legal norms and the process of legal interpretation. Furthermore, algorithms are capable to establish a framework for the use of AI technologies to support the quest for the best solution for hard cases. Their function should be the improvement of logical reasoning and information processing, without interfering with the judicial powers that include subjective appraisals inherent to human intuition.

Algorithms are valuable tools in hard cases of ambiguity or conflict of legal norms. Hard cases beg hard decisions. Such decisions can easily be disputed due to the existence of persuasive alternatives. Logically coherent argumentation is thus necessary for the justification of these decisions and diminishing legal uncertainty. Just like in the decision-making theory, this implies a result-oriented approach, creative considerations of alternatives, and painstaking iterative testing of applicable legal means and goals in a clearly defined sequence.

This endeavour combines objective and quantitative calculations with subjective and qualitative judgments. Thus the art of interpretation cannot be learned from legal norms only; this is a mastery that utilises scientific knowledge, rules of logic and practical experience. If we use Dworkin's analogy of legal interpretation and card playing, we can compare the use of decision-making algorithms with card playing. Just like a skilled card player, a legal interpreter must be apt to take logical steps and make choices between uncertain alternatives to obtain an optimal result. This mastery can be described by the following Sting's verses:

*"He deals the cards as a meditation  
 And those he plays never suspect...  
 He deals the cards to find the answer  
 The sacred geometry of chance  
 The hidden law of a probable outcome  
 The numbers lead a dance."*

## REFERENCES

- [1] Lord Sales. (2019). *Algorithms, Artificial Intelligence and Law*. BAILII.
- [2] Kochenderfer, M. J., Wheeler, T. A., & Wray, K. H. (2022). *Algorithms for Decision-Making*. The MIT Press.
- [3] Miller, A. (2018). Want Less-Biased Decisions? Use Algorithms. *Harvard Business Review*.
- [4] Chernayev, V. M., Mazurchuk, M. T., & Boiko, A. A. (2021). Artificial Intelligence as a Tool for Evaluating the Efficiency of Innovative Technologies for Hard-to-Recover Development. *International Review* 2021(3-4), 31-34.
- [5] Clemen, R. T. (1996). *Making Hard Decisions. An introduction to Decision Analysis*. Brooks/Cole Publishing.
- [6] Tapani Klami, H. (1992). Legal Argument and Decision Theory. *The American Journal of Jurisprudence*, 171-184.
- [7] Council of the Europe Study DGI (2017). *Algorithms and Human Rights*. Available at: <https://rm.coe.int/algorithms-and-human-rights-en-rev/16807956b5>
- [8] Justia (2022). *Bail Algorithms*. Available at: <https://www.justia.com/criminal/bail-bonds/bail-algorithms/>
- [9] Cooter, R. D., & Rubinfeld, D. D. (1989). Economic Analysis of Legal Disputes and Their Resolution. *Journal of Economic Literature*, XXVII., 1067-1095.
- [10] Posner, R. (1986-1987). Legal Formalism, Legal Realism, and the Interpretation of Statutes and the Constitution. *Case Western Reserve Law Review*, 37(2), 181.
- [11] Kelsen, H. (2010). *Über Grenzen zwischen juristischer und soziologischer Methode*. Pravni fakultet Univerziteta u Beogradu.
- [12] Visković, N. (1981). *Pojam prava*. Logos
- [13] von Ihering, R. (1913) *Law as a means to an End*. The Boston Book Company.
- [14] Kantorowicz, H. (2006). *Der Kampf um die Rechtswissenschaft. Zur Lehre vom richtigen Recht Rechtswissenschaft und Soziologie*. Dosije.
- [15] Wendel Holmes Jr., O. (2011). *The Common Law*. University of Toronto Law Schol Typographical Society.
- [16] Kelsen, H. (1934). *Reine Rechtsleere, Einleitung in die rechtswissenschaftliche Problematik*. Franz Deuticke. Serbian translation: (2007). Čista teorija prava. Uvod u problematiku pravne nauke. Centar za publikacije Pravnog fakulteta u Beogradu.
- [17] Dworkin, R. (1977, 1978). *Taking Rights Seriously*. Harvard University Press, Cambridge, Massachusetts.
- [18] Dworkin, R. (1986). *Law's Empire*. Harvard University Press.
- [19] Bovan, S. (2014). *Pravna hermeneutika između filozofije i logike. Sociološki metod u tumačenju i primeni prava*. Pravni fakultet Univerziteta u Beogradu.
- [20] Mc Bride, J. (2021). *The doctrines and Methodology of Interpretation of the European Convention on Human Rights by the European Court of Human Rights*. Council of Europe.

- [21] Alexy, R. (2021). Constitutional Rights, Proportionality, and Argumentation. In *Proportionality, Balancing and Rights* (pp.1-10). Springer.
- [22] Pamučar, D., Stević, Ž., & Sremac, S. (2018). A new model for determining weight coefficients of criteria in mcdm models: Full consistency method (fucom). *Symmetry*, 10(9), 393.
- [23] Rašević, Ž. (2022). Konkretizacija ustavnog načela srazmjernosti ograničavanja ljudskih prava. *Glasnik prava*, 1(22), 17-37.

# Remote Working in the Digital Age: Benefits and Potential Negative Effects

Jelena Lukić Nikolić<sup>1</sup>

<sup>1</sup>Modern Business School, Belgrade, Serbia

<sup>1</sup>jelena.lukic@mbs.edu.rs

**Abstract**—The aim of this paper is to point out the advantages and possible negative effects of remote working which has become popular due to advancement of modern digital technologies. For this purpose, during 2022 were conducted semi-structured interviews with employees from different industries who worked hybrid or remote in previous period. In the interviewing process participated 30 employees which do not hold any managerial position and 10 employees who hold some managerial positions. All collected answers were qualitatively analyzed and presented in this paper. The key conclusion is that while some employees prefer remote work, others prefer to go to office or some hybrid ways of working which means some days working remotely and rest from the office. Human resource managers will be confronted with new challenges how to organize work and satisfy the needs and preferences of employees who work remotely or hybrid.

**Keywords** – digital age, remote work, flexibility, employees, loafing

## I. INTRODUCTION

The development of modern technologies has led to numerous changes in the organization of work of any company which operates in the digital age. Certainly, the most noticeable change is the transition to remote work, instead of going to work in the company's premises.

Although the beginning of remote work was quite challenging and accompanied by numerous problems, such as: inadequate working conditions, insufficient space at home for all family members, unsuitable desks, uncomfortable chairs, small monitors, weak Internet connection, problems with microphones, cameras, adjustment to new collaboration tools and systems, over time employees get used to the new way of remote working and realized the

numerous advantages. That is why employers are confronted with pressing question: how to ensure the return of employees to the offices, without negative effects? The worrying fact is that many employees, especially IT professionals, made decisions to leave employers who insist on returning to the office and sought new employment within the company that allows remote working. For this reason, with the strong desire to retain talented employees, companies have oriented toward various kind of hybrid solutions in which a certain number of days employees work from the office and the rest remotely.

The aim of this paper is to point out the key advantages of remote work, as well as the key negative effects that can occur during remote work.

## II. REMOTE WORKING: STATISTICAL DATA AND KEY TRENDS

Results from various research showed valuable findings regarding remote working and key tendencies in the future. Some of them are [1]:

- Employees who work remotely save on average 40 minutes daily from commuting;
- 23% of surveyed employees would take a 10% pay cut to work remotely permanently;
- People are saving on average almost 500 dollars per month being at home during COVID-19;
- 59% of respondents said they rather choose an employer who offer remote work than those who do not;

- The CEO of Facebook stated that he expects 50% of their workforce to be working remotely by 2030.

Another studies, also showed results in favor of remote working [2]:

- By the 2025, there will be 36.2 million Americans who will work remotely;
- Gartner revealed that 82% of executives expected to offer the ability to work remotely, at least some time post-pandemic;
- Gallup poll showed that 35% of US workers would prefer to continue working completely remote;
- Company GoodHire found that 85% of Americans prefer to apply to jobs with remote work options;
- Job postings on LinkedIn with the tag *remote work* increased by 357% in May 2021 compared to the year before.
- Around 50% of respondents reported that they would resign if their employers demanded returning to the office.

Gallup survey showed that employees who prefer fully working from office feel more productive, have better access to technologies and other resources, collaborate more easily, and feel more connected to the organization. Those employees who prefer hybrid methods of work stated as benefits that they avoid commute time, have the flexibility to balance family and other obligations, feel more productive, and have an option to work in person with co-workers on the days when they come to the office. Finally, those employees who prefer fully remote work stated as benefits that they avoid commute time, have the flexibility to balance their private obligations, feel more productive and have fewer distractions [3].

Professor of management and organization, Margaret Luciano pointed out four ways in which managers can increase employee flexibility without losing productivity. In the digital age, managers will need to think differently about employees who work together, how they share information and with whom, while being fully informed of any change in organization [4]. In this way, productivity will not decrease, and employees will have a greater

degree of flexibility and the ability to balance between professional and private life.

### III. RESEARCH METHODOLOGY

In order to find out what are the benefits of remote working, as well as to analyze potential negative effects, there were conducted interviews with employees who work hybrid or remotely during COVID-19 pandemic.

The interviews were conducted with 30 employees who do not hold managerial positions, as well as with 10 employees who are on some managerial positions. Interviews were semi-structured, with a list of prepared questions. However, according to the flow of conversation, there also appeared some new, sudden questions related to the specific industry and company. Interviews were conducted “one on one” during 2022 year and encompassed employees from four different industries: banking, accounting, IT, and education.

The respondents were born from 1972 to 1997 year, so they have between 25 and 50 years. All of them have finished bachelor or master studies in the field of information technology, economy, finance, and management. All respondents were given the opportunity for remote working in the period from 2020 to 2022, due to COVID-19 pandemic.

The collected answers were qualitatively analyzed and presented in the following titles of this paper.

#### IV. THE KEY ADVANTAGES OF REMOTE WORKING – WHY EMPLOYEES DO NOT WANT TO RETURN TO OFFICES?

During interviews, respondents indicated the following positive effects they experienced while working remotely.

*Savings in commute time.* Employees who work remotely can comfortably get up 5 to 10 minutes before the start of working hours and start working immediately. They don't waste time commuting from home to work and back. Likewise, as soon as employees finish working hours, they are already at home and can devote themselves to other duties and activities. This is especially important for employees who commute to work more than 30 minutes, because in this way they save an hour a day. They have extra time to spend it in a much more efficient and high-quality way. Furthermore, there are regular traffic jams, and it is obvious that remote

work brings a dose of comfort and convenience for employees.

*Less stress because there are no more problems with the parking space.* The insufficient number of parking spaces is well-known problems to all drivers in Belgrade, but also in other major cities. When an employee returns to home tired from work, he often loses an additional time (approximately quarter of an hour) looking for a parking space, which is sometimes quite away from his home. Likewise, in the morning when employee comes to work, if the company has not provided a parking space, employees have already faced the first stress - where to park the car.

*No worries about the weather forecast and what to wear.* Every morning, getting ready for work involves checking the weather forecast and deciding what to wear. Clothing must be prepared - clean, ironed and adapted to the needs of work and appointments. When working remotely, employees do not have those worries and can devote themselves to other, more useful activities.

*Easier management and coordination of family/other obligations.* Many times, it happens to employees that they cannot be sure when they will return home from work due to traffic jams, transportation, and parking, which makes it more difficult for them to plan family obligations and other activities. When they work remotely, they can be sure that they will be available to their family as soon as they finish work, and they can manage their private time more easily and with greater precision.

*Doing some of the household chores.* Modern technology has penetrated in all areas and segments of our life and work. For employees who work remotely it only takes a few minutes to turn on a washing machine, a dishwasher, a smart-multi-cooker, and the like. Employees who work remotely only need a few minutes (less than five minutes) to turn on these devices and during the day they are able to perform some minor household tasks that would otherwise await them in the evening when they come home from work.

*A healthier food and more proper nutrition.* Employees often want to sleep as long as possible in the morning, so they have time to just get dressed and go to work. Sometimes it happens that they have an important meeting right at the beginning of working hours. They

quickly buy some bakery products, sandwiches, muffins, puff pastry, snacks, carbonated drinks, coffee. When employees work remotely, they can prepare a meal according to their own wishes and eat much healthier food. There are also significant savings in money spent on meals for employees who work remotely, and the fact that they can eat when they are hungry.

Another seemingly minor but significant benefit of remote work that respondents stated is *the ability to easily pick up a shipment they ordered online.* Employees who work from office have difficulties when they expect such shipments because they never know when they will arrive home and whether any of the family members will be at home and able to receive the shipment or they will have to look for it and go to the nearby post office to pick it up.

All these advantages and benefits mean a lot to employees and contribute to the overall quality of their lives. These are primarily a lower degree of stress, less tension, nervousness, frustration, easier management and coordination of family and private obligations, more free time, and a greater degree of satisfaction. Many employees stated that there is no money which can bring them back to the office. On the other hand, many companies that predominantly apply remote working have noticed that certain employees are loafing and working less. That is why they became focused on strategies of returning employees to offices.

## V. THE POSITIVE EFFECTS OF WORKING AT THE OFFICE - WHY EMPLOYEES WANT TO RETURN TO THE OFFICES?

In addition to the numerous advantages that remote work brings, there are also certain negative effects that make employees look forward to returning to the office. During the interviews, respondents stated the following reasons why they want to return to the office.

*Easier exchange of knowledge and experience.* Although modern technologies enable various tools for employee collaboration, it is difficult to exchange some specific knowledge and experience in that way. When employees are gathered in the office, the opportunities for knowledge sharing are much greater. Employees are happy to share their experiences and help each other to complete their work better and more efficiently.



*Receiving better and precise information about company.* When employees are present in the office, they are better informed about organizational plans, goals, further development directions and activities. On that way, employees get all the necessary information, as well as additional guidelines and explanations, in a faster and simpler way.

*The need for proposal of new ideas and different approaches.* Employees want to work from the offices with the aim to have active discussions and exchange of opinions with colleagues, and other teams and departments. They are aware of the opportunities that teamworking brings - to jointly come up with a better solution to a problem or to make a better proposal for a project.

*Desire for progress and career development.* When working remotely, employees often feel isolated and that their work and efforts are not properly monitored and appreciated. They believe that they will make better impressions on managers and co-workers while working at the office. As a result, employees believe that this will create a better chance for them to advance to some better positions. Furthermore, employees who work from the office have the opportunity to receive real-time feedback from managers and superiors on the achieved work results, as well as possible directions for improvements.

*Adequate infrastructure and space for work.* Comfortable chairs, suitable desks, adequate infrastructure, and other means of work await employees in the office. Many employees who work remotely do not have ideal conditions and want to return to the office as soon as possible to

enjoy the comfort and convenience. Also, many employees who work remotely do not have ideal lighting, internet connection, the ability to be alone and concentrate to work. Furthermore, they often encounter the attitudes of other family members that “they are not so burdened with work”, which is why they often receive requests to do some activity while working, which may lead to dissatisfaction, frustration and stress.

*A sense of belonging.* Employees who work remotely for long periods of time are often said to feel “out of sight, out of mind” which makes them feel isolated and less important to the organization. When they come to the office and are surrounded by colleagues, they develop a sense of belonging to the organization and an increase in work ethic and morale. Employees feel that they are part of the collective and that the organization is their second home where they spend one third of the day.

*Wish to leave the house and surround with other people.* Employees who work remotely are often deprived of many experiences and events, they feel lonely, in the monotonous atmosphere of their home, without contact and interaction with others. That is why many employees need a change of environment and leaving the house. Many of them want to experience something new and different. Employees who work remotely stated that they have gained weight, became less tidy, lazy, messy, haven't renewed their wardrobe for a long time, and the like.

*Socializing with colleagues.* There is no better feeling than seeing colleagues, drinking the first morning coffee with them, sharing

TABLE I. ADVANTAGES OF REMOTE AND OFFICE WORKING.

<i>Remote working</i>	<i>Office working</i>
<ul style="list-style-type: none"> <li>• Savings in commute time</li> <li>• Less stress because there are no problems with the parking space</li> <li>• No worries about the weather forecast and what to wear</li> <li>• Easier management and coordination of family/other obligations</li> <li>• Doing some of the household chores</li> <li>• A healthier food and more proper nutrition</li> <li>• Ability to easily pick up a shipment ordered online</li> </ul>	<ul style="list-style-type: none"> <li>• Easier exchange of knowledge and experience</li> <li>• Receiving better and precise information about company</li> <li>• The need for proposal of new ideas and different approaches</li> <li>• Desire for progress and career development</li> <li>• Adequate infrastructure and space for work</li> <li>• A sense of belonging</li> <li>• Wish to leave the house and surround with other people</li> <li>• Socializing</li> </ul>

Source: Author interpretation based on conducted interviews

important information, joking, and starting the day with laughter.

All above mentioned answers of respondents, fostered them to go to the office, or to use some hybrid methods of working.

In Table I are presented all advantages of remote work and work from the office.

## VI. STRATEGIES OF LOAFING AND SIMULATING HARD WORKING

Numerous studies have shown that there is only a small number of dedicated and engaged employees in companies. There is an increasing number of employees who come to work to loaf and procrastinate their tasks and impatiently wait for the end of the month to receive a salary [5]. In the desire to work as little as possible, employees developed numerous strategies and tactics with the aim to create false impression to colleagues and managers that they are overloaded with work.

In literature and practice, the expression “loafing effect” has become popular, especially in the digital age. It describes the behavior of individual employee which reduces the level of work, commitment, effort, and contribution [6]. Cyber loafing is a special type of loafing in which employees spend a certain (rather large) part of their working time on private social networks and various portals for their private reasons and entertainment [7].

Employees who want to present themselves as hard-working, dedicated, and engaged developed a whole set of strategies, activities, and techniques to create the illusion of being overwhelmed with work. Managers who participated in this research observed the following employee strategies.

*An open document on the computer* - employees always have some document opened on the computer and they pretend to be working when colleagues or superiors are present in the office. Such employees purposefully open document at the beginning of working hours and occasionally move pages through time, in order to create the impression that they are doing something important.

*A briefcase that they always take home and bring to work* – carrying a briefcase gives the impression that employees have too much work they need to bring home in order to meet the deadlines. In this way, employees want to create

an impression on managers and colleagues that they are dedicated and committed to work. Furthermore, it is common situation in practice that these employees took their briefcase and hurriedly walk near managers and superiors in order to be noticed by them.

*Pseudo-commitment to work* - employees often come the first to the office and leave it last with the aim to create the impression that they have too much work and are highly dedicated, conscientious, and responsible. At the end of the working hours, these employees wait for everyone to leave, pretending to work, and then quickly gather their staff and go out of the building.

*Waiting for the deadline to submit the completed work* - employees often complete the tasks they were given and then wait for the agreed deadline to submit them. In this way, employees have enough time to devote themselves to some other interests. Some employees go one step further, so if they finish the tasks quickly (after only a few days), and plan to send it the next month - they go into the files and change the dates to make it look like they managed to complete the task just that day or one day before the deadline.

*Giving unrealistically long deadlines for the completion of tasks* - employees purposefully specify a longer period for the realization of tasks in order to have enough time to devote themselves to other interests. These situations are especially common in jobs for which managers cannot objectively assess how much time employees need. When employees are aware that their superiors are not knowledgeable in their segment of work, they feel free to give unrealistically long deadlines and thus magnify their part of the work.

*Pretending to be overloaded with work* - employees may pretend that they have too much work and that they cannot accept a new task. They often point out that they are tired, that they cannot accept any new task because they have a lot of unfinished work from the previous period.

*Simulating that they are present, but they are actually absent from work* - one of the often applied tactics of employees is to leave an open document on the computer, papers scattered on the desk, reading glasses, a spare coat or jacket on the coat/jacket hanger, with the aim to create the impression that he/she is somewhere in the building, while in the fact he/she is already one,

two or even three hours absent (walks, solving some private issues, etc.).

All above mentioned activities have negative effect on efficiency, effectiveness, quality of work, products, services, business processes and productivity. The loafing effect is one of the most pressing problems in remote work due to reduced possibilities of insight into the work of employees who are not physically present at the office. Recommendations and suggestions that can be used to reduce the loafing effect during remote work are regular meetings via videoconferences and more frequent reporting on the activities carried out - for example reporting on a weekly basis.

## VII. CONCLUSION

Modern technologies that are used in companies provide the opportunity for remote work. More and more employees want to have the possibility to work remotely. This is especially noticed among younger generations which are familiar with technologies and tools and prefer flexibility.

The conducted interviews shown that employees experience certain advantages when working remotely, as well as some negative effects. Furthermore, results shown that managers are frequently surrounded with employees who are prone to loafing effect, not only when they work remotely, but also when they are present in the office.

Every employee has different needs and motivators when it comes to choosing a place of work. For that reason, many companies introduce hybrid methods of work by having employees work from the office for a certain number of days in a working week, while the rest of the working week they can work remotely. In this way are achieved all the advantages of both type of working.

It is certain that newer generations of employees will prefer remote or at least hybrid methods of working. Development of modern

technological solution will be oriented toward improved types of collaboration and communication. That is why all companies need to be prepared how to engage employees who will work remotely or hybrid and how to prepare adequate value proposition in order to make them efficient, productive, motivated, committed and engaged.

The limitation of conducted research is the number of respondents (30 employees and 10 managers) and their structure (four type of companies: finance, accounting, IT, education). As a result, obtained results cannot be generalized. Proposition for future research on this topic is to encompass a larger number of respondents and to make a special questionnaire for gaining more objective results.

## REFERENCES

- [1] ApolloTechnical Engineered Talent Solution (2022). *Statistics on remote workers that will surprise you (2022)*. Available at: <https://www.apollotechnical.com/statistics-on-remote-workers/#:~:text=Statistics%20on%20remote%20workers%20reveal,to%20an%20Owl%20labs%20study>. (07. 11. 2022).
- [2] Robinson, A. (2022). *Remote Work Statistics & Facts for 2022*. Available at: <https://teambuilding.com/blog/remote-work-statistics> (08. 11. 2022).
- [3] Saad, L., & Wigert, B. (2021). *Remote Work Persisting and Trending Permanent*. Available at: <https://news.gallup.com/poll/355907/remote-work-persisting-trending-permanent.aspx> (06. 11. 2022).
- [4] Luciano, M. (2022). *4 Ways Managers Can Increase Flexibility Without Losing Productivity*. Available at: <https://hbr.org/2022/02/4-ways-managers-can-increase-flexibility-without-losing-productivity> (06.11.2022).
- [5] Lukić Nikolić, J. (2021). *Angažovanost zaposlenih sa organizacionim ponašanjem i menadžmentom ljudskih resursa*. Beograd: Visoka škola modernog biznisa.
- [6] Byun, G., Lee, S., Karau S. J., & Dai, Y. (2020). Sustaining Collaborative Effort in Work Teams: Exchange Ideology and Employee Social Loafing. *Sustainability*, 12(15), 241.
- [7] Ugrin, J. C., Pearson, J. M., & Odom, M. D. (2008). Profiling cyber-slackers in the workplace: Demographic, cultural, and workplace factors. *Journal of Internet Commerce*, 6(3), 75-89.

# The Role of Social Media in Coups d'État

Tanja Milošević<sup>1</sup>, Nina Milošević<sup>2</sup>

<sup>1</sup>Faculty of Political Sciences, Belgrade, Serbia

<sup>2</sup>Faculty of Organizational Sciences, Belgrade, Serbia

<sup>1</sup>tanja.z.milosevic@gmail.com, <sup>2</sup>ninamilosevic1999@gmail.com

**Abstract**—Many have believed that coups d'état represent phenomenon of the past, given the widespread of democracy, rule of law, and free, fair and credible elections. However, violent changes in regimes, occurring in many countries of Africa and Asia since the beginning 21st century, as well as constant emergence of constitutional crises and the fight for introduction of third term in two-term presidencies has put the study of coups d'état to the fore. Building on the previously acquired knowledge on this phenomenon, we albeit acknowledge the fact that globalization, spread of technological advances, and especially the use of Internet and social networks, has slightly changed the methods of execution of coups, but also the coup-proofing methods. Therefore, in this paper, the authors will examine the changes introduced by the rise of technology, with a special emphasis on three focal points: the impact of social media on the conduct of coups; the impact of social media on information, disinformation and misinformation dissemination; and the impact of social media, Internet and encrypted communication apps on coup success. The presented research will be conducted with the use of methods of data collection and content analysis, as a response to research question constructed as following: “To what extent have Internet, social media and encrypted messaging apps changed execution, research and perception of contemporary coups d'état?”.

**Keywords** – social networks, coup d'état, political violence, Twitter, Facebook.

## I. INTRODUCTION

For a long period of time, and especially since the beginning of the 21<sup>st</sup> century, the academic community has continuously reiterated that coup d'état represents a phenomenon of the

past. However, the past two decades have served as a reminder that violent overtake of power by the armed forces in many countries, albeit most often in African and Asian climates, that is, in countries that are best defined as *semi-democracies*, is a method often used for changing political climates across the globe. Violent takeover of power by the armed forces nowadays is most often embodied in the form of a *coup d'état*, emerging as a strong response to “the failure of democracy” [1], as well as political fragility [2] of “new democracies”, unable to defend their Constitutions, as well as the true meaning of democracy, when faced with the idea of lifelong leaderships, constitutive crises and introduction of unconstitutional third term in two-term presidencies.

For the purpose of this research, *coup d'état* will be defined as an action partaken by a military branch or a group of officers directed towards violent or bloodless deposition of the current political leadership, and especially the president. The main perpetrators are most often embodied in the form of a *military junta*, a group of army officers determined to take over the country. The said takeover is often executed in the following five phases: planning, organization, execution, proclamation of coup, and legitimization of power. Given the topic of this research, it must be noted that globalization and spread of Internet, and thus social media and encrypted communication apps as well, has truly impacted the method of execution of coups, but also detection and coup proofing actions as well, thus justifying the need for conducting this research.

Namely, the continents most affected by coups d'état – Africa and Asia, have been identified as sort of *late boomers* when speaking

of Internet, and therefore social media access. Even though the *World Wide Web* was created in 1989, African and Asian population just started discovering the perks of Internet in the first years of the 21<sup>st</sup> century [3]. And as it can be noted from examination of spread of Internet on these continents, the intensified occurrence of coups d'état accidentally coincides with the increase of social media access, which demanded for the previously mentioned changes in methods of execution, monitoring, reporting and prevention of coups.

When speaking of execution of coups d'état, that is, preconditions for any monitoring, reporting and prevention activities, it is obvious that all phases of the coup have been *touched* by technology, thus making the coup plotters adapt to the new age of coup-making. As it was previously stated, the biggest shift was recorded within the fourth stage of the coup – proclamation of seizure of power, given that, in the past, the predominant medium for presidential office takeover were television and radio broadcasting, whilst nowadays the modern *junta* live streams the execution and publish statements via social media [4]. Given that we are speaking of quite a complex shift in *modus operandi*, which also affects other phases of coup-making, as well as the aftermath, the following occurrence will be closely examined in the following chapter.

The shift in proclamation of a coup, as well as the other phases of coup-making, also affect the perception of the coup activity in the public sphere, especially given the fact that live streaming and public broadcasting on social media prompts fast spread of news, thus creating a fertile ground for dissemination of information, but also misinformation and disinformation, both intentionally and unintentionally. The quality and quantity of (dis/mis)-information [5] therefore impacts the outcome and response of the public to the rise of the new *military junta*, thus elevating the need for scientific examination of the impact of Internet, media, social networks and their products in the cyberspace on the aftermath of the coup.

Finally, given that every action causes a reaction, the success of a coup is most often determined by the final phase – legitimization of power, which occurs sometimes even several years after the execution, with implementation of free, fair and credible presidential elections. However, it must be noted that the success of a

coup is also dictated by the public perception, but also the perception of the international community and main stakeholders, which have a tendency to “nip the coup activities in the bud”, that is, implement a certain set of measures as a form of coup-proofing, with the goal of preventing, thwarting and negating the coup d'état. Having this in mind, we deem examination of impact of Internet and social media on logistical segment of coup execution and coup-proofing as quite a significant contribution to the academic perception of practical implementation of theoretical knowledge. In this context, as most valuable to be presented are the mere impact of massification of coup execution through the use of social media, such as *Twitter* [6], the importance of maintaining secrecy in communication, which is nowadays enabled through different encrypted communication apps, as was the case in 2016 Turkey coup d'état and *ByLock* app [7], and finally, the speed of spread of the news of the coup not only in the country, but also worldwide.

Thus, the research before you is constructed multidisciplinary – providing analyses from two different standpoints – media analysis and analysis of political processes, but is also threefold, given that it researches the impact of social media in the conduct of coups through coup proclamation; information, disinformation and misinformation surrounding the coup and the final impact of media and internet, which serves as a final decision-maker when speaking of the success of the coup.

## II. GLOBALIZATION AS A GAME-CHANGER

As it was previously stated in this paper, globalization has a great impact on the execution and detection of coups, as well as on coup-proofing actions. Therefore, for this research, *globalization* will be defined as a process of integration and interaction among various subjects worldwide, such as companies, people, and governments. In the age of globalization, country borders are no longer considered barriers when it comes to international trade, exchange of ideas, and communication. This fact has made this world a global village. Suffice it to say that globalization has closed the gaps that existed among states as they are constantly interdependent in economic, socio-cultural, and political terms [8].

Having all this in mind, we can conclude that globalization is an ongoing, omnipresent process that has been greatly accelerated and influenced

by advances in communications technology. Advancement in technology is considered to be one of the major drivers of globalization [9-11].

Thomas Friedman has described the three stages of globalization:

- Globalization 1.0, which refers to the global expansion dominated by nations;
- Globalization 2.0, which refers to the rise of multinational companies; and
- Globalization 3.0, which refers to advances in global electronic interconnectivity that allowed individuals to communicate as never before [12].

One should have in mind that, even though globalization is primarily viewed as an economic process, it is important to point out that international diplomacy and disputes have been greatly influenced by globalization as well. The thought behind globalization rests on fusing the world into a single entity by developing every area of modern society. However, this process brought up challenges when it comes to inequality and insecurity as it has created new, modern weapons of resistance for individuals who oppose certain political measures and ideologies. Furthermore, there is an increase in criminal activities across national borders as a result of globalization [13].

According to the *Global Digital Overview* published in the previous year, out of the 7.91 billion people in the world, the global number of users of the internet had reached about 4.95 billion, of which 4.62 represent social media users [14].

Between 2019 and 2021, Internet use in Africa and the Asia-Pacific region jumped by 23 percent and 24 percent, respectively. Over the same period, the number of Internet users in the least developed countries increased by 20 percent and now accounts for 27 percent of the population [15].

Since the number of Internet and social media users is increasing day by day in the contemporary world, it has never been easier to connect with people, and discuss common topics and interests, but also spread misinformation and cause panic. Social media accounts provide users with a veil of anonymity and allow them to gain great power and influence among their like-minded peers. Also, the numerous privacy

policies of the various applications that users can use to communicate allow them to share their opinions freely and honestly. Privacy policies are very important to modern users who increasingly strive for complete privacy and value the importance of information, but these privacy policies protect those users who do not aim to protect their identity but strive to create unrest by spreading important information, knowing that their conversations are encrypted.

Having all previously stated in mind, the following three sections will present the impact of social media, information, disinformation and misinformation dissemination, as well as encrypted communication had on contemporary coup execution and coup-proofing techniques.

#### A. *Executing a coup d'état in the Era of Social Media*

As we have previously stated, all phases of coup d'état execution have been, to a lesser or a greater extent, impacted by globalization and the rise of technology, in this case embodied in the form of Internet and thus access to social media and encrypted communication apps. Given that the issue of encrypted communication apps will be specifically examined in the final segment of this chapter, the following lines will be dedicated to defining impact of media and social media on every single phase of coup d'état execution, with an emphasis on the phase four – proclamation of a coup, since the most significant impact of technology on the second phase – i.e., organization – will be examined in detail in the final segment.

- Phase-zero, that is, the initial phase of every coup activity, is defined as planning, which implies inception of the idea of changing the political geography of a country through staging a full-scale change in power. The said phase is essentially defined by the notion of conspiracy, given that keeping the idea of an overthrow a secret is one of the most significant variables that could impact the success of the coup. In this sense, maintaining “low profile” and implementing “radio silence” technique serve as good protection from being detected even before the plan is being set in motion. In this segment of the coup planning, as well as in the organization phase, the biggest contribution to coup-proofing and maintenance of *status quo* in the country is provided by

implementation of target-oriented machine learning algorithms, given that such actions have already proven successful in counter-terrorism and radicalization prevention actions[16-18].

- The second phase of every coup-making activity is centered around planning, that is, organization of a coup [16]. The said phase includes not only the mere logistical planning of the physical execution of a coup, but also *recruitment* of the future putschists, formation of the future *junta*, as well as maintaining secretive communication and avoiding detection of the subversive actions in question. In this sense, social media can play a significant role, especially when speaking of recruitment of potential plotters, having in mind that contemporary mankind often uses social media for expressing social discontent and dissatisfaction with the living-conditions, political situation and finally – the ruling elite. From this pool of positive or negative comments, future *junta leader*, with implementation of basic psychology and psychobiography tools, can pluck suitable collaborators. Experts researching other political violence phenomena, and especially terrorism and extremism, have many times stressed the fact that *social engineering* plays quite a significant role in recruitment of vulnerable and marginalized individuals [19], and thus, in this context, it must be noted that this method might be implemented in the case of coup-plotting recruitment as well. Moreover, the success of recruitment, when finalized, is yet to be put to a test, given that a successful coup can be executed only in complete secrecy, that is, with avoidance of all detection of subversive communication, which will be further elaborated in segment C of this chapter.
- Phase three entails execution of a coup d'état, whether it be violent or bloodless, albeit the latter, having in mind the contemporary promotion of human rights, is preferable. In the olden times, conducting a coup seemed quite easy – namely, as depicted by [20], you only have to “get the keys to the armory; turn out the barracks; take the radio station,

the post office and the airport; [and] arrest the person of the president and you arrest the state...”. Nowadays, with the omnipresence of Internet, and thus social media and free access to livestreaming actual ongoing events, the goals of the putschists have slightly changed, as it can be confirmed with execution of Malian coups of 2020 and 2021. Namely, in the morning of August 18, 2020, a party of army officers begun a mutiny in a military base, which soon culminated into deposition of the ruling party, and the head of the state as well. Soon enough, the video footage of army officers storming the luxurious palace of the son of the deposed President Ibrahim Boubacar Keita inspired the masses to storm the streets and demand deposition of the president [21]. Albeit, this story soon enough turned out to be a piece of disinformation, given that the residence in question was of a different individual, but still, the news served the purpose and drove people to the streets. On the other hand, the 2021 coup d'état in Myanmar serves as a good example of how social media and Internet can also be misused by the putschists, given that, in this case, aware of the power of social media, which positioned itself as the “Fifth Estate” in this country, they decided to block all Internet access in order to “suppress the [negative] discourse and public propaganda” [22] and ensure success of their unconstitutional actions. What should also be noted is the fact that execution of the coup and its public screening on social media is also a suitable tool for conducting analyses on the coup execution and general opinion, which can be conducted with the use of many tools nowadays offered online [23,24].

- Phase four of coup execution refers to proclamation of a coup, that is, public addressing of the *military junta leader* to the nation. This has always been deemed as the most distinctive segment of coup execution, given that, before the era of Internet and fast access to news, the general public was to be aware of the coup only after the dust has settled and the officers have taken the Presidential Palace. The traditional coup-makers

usually had all the intentions of taking over the Presidential Palace, making the next stop at the most prominent and widespread television or radio station, depending on the population of the former or the latter in the given region. Nowadays, this issue is resolved by the fact that public addressing and official statements can be easily recorded via cellphones or even livestreamed on social media platforms. Even when accessing video footage of official first addressing of several coup leaders over the last decade, a shift can be seen from overtaking media houses to simply organizing conferences, from where many media representatives have the opportunity to share their thoughts and visions of the new leader with the public instantly. To this sense, it can easily be said that the PR service surrounding the persona of the new leader of the state has shown much improvement, and thus leaves space for further examination of the methods by which the ideas and plans for the homeland are being transmitted to the public as well. Moreover, many public figures, and thus *junta leaders* as well, nowadays have official profiles on various social media platforms, thus facilitating their outreach to the general public.

- The final, fifth phase, is achieved with most difficulties, given that, in order to legitimize power, a *military junta* must first survive in power for seven days in order for a coup to be proclaimed a success. Afterwards, a *Transitional Government* is usually being formed, most often for the period of two years. As stated by [25], Transitional Governments are most often formed in order to continue peace talks and maintain *status quo* in the country. However, the true purpose of (almost) every Transitional Government is to ensure enough time for the coup leader to conduct complete overtake of the country and ensure a sure win on the subsequent presidential elections. Namely, only through participation and winning presidential elections can a *junta leader* become a legitimate president. In this sense, the impact of Internet and social media has proven to

be twofold in this phase: as in the case of Myanmar coup, the rule over the country enables the *junta leader* to have a grasp on Internet access and thus social media, with the sole intention of controlling the public discourse and directing it to the *junta's* advantage and, when speaking of Presidential campaigns, social media can be used as substantive platform for spreading propaganda and reaching the wider masses. Namely, "Platforms such as *Facebook*, *Twitter*, or *Reddit* have changed how political campaigns are run; how politicians and the public access and share political information; and the way we learn about politics, form opinions and attitudes, and ultimately engage in or disengage from the political process" [26].

Therefore, from the previously depicted phases of coup-making, it is evident that every segment of conducting a coup has witnessed a significant influence that has shifted the methods of execution of coups, but also the coup-proofing methods.

#### *B. Information, misinformation and disinformation as servants/opponents of the coup*

As we have witnessed many times throughout the history of the mankind, the importance of access to information in the times of grand political turmoil is of greatest importance when speaking of maintaining peace and tranquility. However, these times also represent a fertile ground for conception of numerous pieces of misinformation, but intended disinformation as well.

For the purpose of this research, *information* will be defined as a piece of news that provides true facts about certain event, whilst *misinformation* and *disinformation* refer to untrue piece of news, with the difference depicted in the fact that the former represents an (accidentally) wrongly presented information, while the latter refers to intentionally misleading the public regarding a certain topic [27].

As it was explained on the example of 2020 Mali coup d'état, fast spread of information can often serve as an advantage to the coup-plotters, given that, in this example, this subversive activity was greeted with positive attitude of the majority of general public, and the people stormed the streets as a sign of support to the new



military rule. However, such speed of spread of news also invites a prompt response of the international community and thus international organizations, as was the case with the coup in question, given that soon enough were sanctions imposed on the new regime by the United Nations, African Union and Economic Community of West African States [28]. One should have in mind the gravity and consequences of imposing sanctions on any state, and especially the new government, given the fact that the main promise of every *junta* is always that the future of the nation will be better, and not sanctioned.

The same coup proved to be a good example of spread of misinformation as well, given that certain journalists reiterated that, in the first hours of the Malian coup of 2020, there were claims circulating the Internet that the deposed president was arrested by the French army [29]. Such misinformation, to one extent, introduced confusion among the general public, and to the other, raised dissatisfaction with the local population, who traditionally perceives the French as colonizers.

Finally, disinformation and propaganda campaigns are the mighty swords of the Modern Times, often drawn at any occasion and directed towards every type of opponents – from political rivals to the disbelieving people. In this sense, disinformation techniques and spread of such news are most often applied in the close aftermath of a coup, and are quite regularly directed towards diminishing the claims of other pretenders to the ‘throne’, as well as towards calming the public. Albeit, this sword can turn against the putschists as well, as history has taught as well.

### C. Encrypted communication and coup-proofing

The rapid development of social networks and application encryption has contributed to an increasing convergence of users who use social networks to join together to achieve common goals related to several political disorders that are not uncommon in today’s society. It is difficult to predict the chaos that can potentially arise within a nation or state, but what these threats have in common is that they can often be organized and coordinated using social networks and the Internet.

Evidence indicates that activists and other participants used social media during civil unrest

to express political opinions, communicate with fellow citizens, and organize future events [30]. Research shows that social media played an important role during the Arab Spring uprisings. For example, active information flows related to the revolution were detected between multiple types of Twitter users, including activists, bloggers, and journalists [31]. The same is the case with the coup-making process.

Secrecy of communication was previously deemed to be the feature of groups directed towards conducting an illegal action, i.e., terrorist groups, organized crime groups, coup-plotting groups, etc. However, these apps are nowadays available to the general public, whilst apps such as *Signal*, *iMessage*, *Telegram*, *Wire*, *Threema*, *WhatsApp*, *WickrMe*, to name just a few, are currently deemed as the most secure ones [32]. As we have previously stated, the perpetrators of the failed 2016 coup d’état in Turkey used *ByLock* messaging app for their communication, which was later detected by the Turkish Intelligence Service *MIT*, whilst the discovered communication was also used for the arrest of some 75,000 people for even downloading the said app [33].

Moreover, it is important to point out the shifts that resulted from the change of ownership of the *Twitter* company when it was transferred to the hands of Elon Musk. Musk introduced the “blue tick” subscription option, which has the function of confirming the identity of the account owner. The subscription option of only 8 USD per month allowed any person to assume the identity of anybody in the world and to spread (dis)information from a “verified” account, which is exactly what happened in several cases. The biggest damage was suffered by certain companies whose reputations were destroyed in this way. Fortunately, this security threat was identified very quickly and the subscription plan was revised, whilst a new method of account verification is currently being prepared that will prevent misuse. The short-term possibility of assuming someone else’s identity for only 8 USD a month is just one of the ways in which Internet users can hide behind a fake name, and spread propaganda and information to their followers.

Another popular application that offers the possibility of anonymous communication is the social network *Telegram*, previously listed as one of the best encrypted communication apps, which offers the option of creating a conversation in which there can be up to 250,000

members who can freely connect under fictitious names. *Telegram* groups have already been recognized by researchers and policy makers as fruitful pools for recruitment of individuals prone to radicalization for terrorist and extremist purposes, thus calling the international community to find a suitable solution for protection of these most vulnerable categories.

Moreover, what characterizes today's social networks is the so-called "vanish mode" that applications offer to their users. Namely, this mode works by deleting the conversation between two users after they shut down the said application, which ensures the participants that their conversation will remain private. This is especially the case with the *Instagram* and *Facebook* apps.

### III. CONCLUDING REMARKS

The research before you was constructed as a form of an interdisciplinary experiment and exchange of thoughts regarding a phenomenon of political violence that has witnessed an awakening, especially in African and Asian semi-democratic countries. The idea of addressing such phenomena one-sidedly is outdated, as was obviously our perception of coups d'états as a thing of the past.

Approaching the issue of coups d'état, thus, from the standpoint of researcher of political violence, hand-in-hand with a researcher of organizational sciences, proved to be quite fruitful, given that, in this way, data collection and content analysis was conducted and reviewed twice, thus providing interesting insight in the role of globalization, and therefore the Internet, media and social media, in the coup-making and coup-proofing processes. May this small contribution to the understanding of this phenomenon be only a first step towards constant multidisciplinary approach and response to political violence, and especially coups d'état.

### ACKNOWLEDGMENT

We thank professor Dr Marija Đorić of the Institute for Political Studies for stressing the importance of multidisciplinary research and joining efforts in finding pieces of a puzzle called political violence.

### REFERENCES

[1] Birikorang, E. (Ed.). (2013). *Coups d'état in Africa – A Thing of the Past?*. Kofi Annan International Peacekeeping Training Centre, Policy Brief 3/2013.

[2] Ben Barka, H., & Ncube, M. (2013). *Political Fragility in Africa: Are Military Coups d'Etat an Never-Ending Phenomenon?*. African Development Bank, Chief Economist Complex.

[3] Roser, M., Ritchie, H., & Ortiz-Ospina, E. (2015). *Internet*. Available at: <https://ourworldindata.org/internet>.

[4] Korotayev, A., & Khokhlova, A. (2022). Revolutionary events in Mali, 2020–2021. In *New Wave of Revolutions in the MENA Region: A Comparative Perspective* (pp. 191-218). Springer International Publishing.

[5] Sierra Caballero, F., & Sola-Morales, S. (2020). Media Coups and Disinformation in the Digital Era. Irregular War in Latin America. *Comunicación y Sociedad*, e7604.

[6] Hughes, G. (2016). *How do military coups fail?* Kings College London, Defence Studies Department.

[7] Blunden, B. (2021, February 4). *Don't Trust Those 'Secure' Messaging Apps*. Available at: <https://www.theamericanconservative.com/dont-trust-secure-messaging-apps/>

[8] Njoku, E. T. (2011). Globalization and cyber terrorism in Nigeria: which way forward. *International Journal of Management, Social Sciences, Peace and Conflict Studies*, 4(1), 85-102.

[9] Bang, K. E., & Markeset, T. (2012). Identifying the drivers of economic globalization and the effects on companies' competitive situation. In *Advances in Production Management Systems. Value Networks: Innovation, Technologies, and Management: IFIP WG 5.7 International Conference, APMS 2011, Stavanger, Norway, September 26-28, 2011, Revised Selected Papers* (pp. 233-241). Springer Berlin Heidelberg.

[10] Bauernfeind, M. (2006). *Drivers of globalization: Integration of theories and models*. GRIN Publishing.

[11] Garrett, G. (2000). The causes of globalization. *Comparative political studies*, 33(6-7), 941-991.

[12] Thomas, L. F. (2005). *The World Is Flat*. Farrar, Straus and Giroux.

[13] Ahmed, N. (2016). The effect of globalization: terrorism and international crime. *IOSR Journal of Business and Management*, 18(11).

[14] Kemp, S. (2022). *DIGITAL 2022: GLOBAL OVERVIEW REPORT*. Available at: <https://datareportal.com/reports/digital-2022-global-overview-report>

[15] ITU Data Hub. (n.d.). *Internet use: Internet uptake has accelerated during the pandemic*. Available at: <https://www.itu.int/itu-d/reports/statistics/2021/11/15/internet-use/#:~:text=Between%202019%20and%202021%2C%20Internet%20use%20in%20Africa,accounts%20for%2027%20per%20cent%20of%20the%20population.>

[16] Luttwak, E. (1969). *Coup d'état: A Practical Handbook*. The Pinguin Press.

[17] Đorić, M., & Milošević, T. (2021). Abuse of artificial intelligence in terrorist and extremist groups [Zloupotreba veštačke inteligencije u terorističkim i ekstremističkim grupama]. *Srpska politička misao*, 71(1/2021), 201-221.

[18] Verhelst, H. M., Stannat, A. W., & Mecacci, G. (2020). Machine learning against terrorism: how big data collection and analysis influences the privacy-security

- dilemma. *Science and engineering ethics*, 26, 2975-2984.
- [19] Sabouni, S., Cullen, A., & Armitage, L. (2017). The use of social engineering techniques in online radicalisation. In *International Conference on Cyber Situational Awareness, Data Analytics and Assessment (CyberSA 2017)*, 19-20 Jun 2017, London, UK.
- [20] Pinnock, D. (1997) *Voices of Liberation. Volume 2*.
- [21] France24. (2020). *In Mali, demonstrators target symbolic places of power*. Available at: <https://observers.france24.com/en/20200819-mali-demonstrators-target-symbolic-places-power>
- [22] Sieany, V. (2021). The power of social media in politics: A case study of Myanmar coup d'état. Available at: <https://www.praxis.co.id/stories/read/268/The-Power-of-Social-Media-in-Politics-A-Case-Study-of-Myanmar-Coup-D-Etat>
- [23] Hua, T. et. al. (2013). Analyzing Civil Unrest through Social Media. *Computer* 46(12), 80-84.
- [24] Wu, C., & Gerber, M. S. (2017). Forecasting civil unrest using social media and protest participation theory. *IEEE Transactions on Computational Social Systems*, 5(1), 82-94.
- [25] Papagianni, K.. (2008). *Power sharing, transitional governments and the role of mediation*. Centre for Human Dialogue.
- [26] Dimitrova, D., & Matthes, J. (2018). Social Media in Political Campaigning Around the World: Theoretical and Methodological Challenges. *Journalism & Mass Communication Quarterly*, 95(2), 333-342.
- [27] Santos-D'Amorim, K., & Fernandes de Oliveira Miranda, M. K. (2021). Misinformation, Disinformation, And Malinformation: Clarifying The Definitions And Examples In Disinfodemic Times. *Encontros Bibli, revista eletrônica de biblioteconomia e ciência da informação, Florianópolis*, 26, 01-23.
- [28] Dietz, C. (2022). *How will sanctions on Mali affect the West Africa region?* Available at: <https://african.business/2022/03/trade-investment/coups-and-sanctions-in-the-sahel-and-west-africa-what-you-need-to-know/>
- [29] Davis, S. (2020). *Mali: Misinformation circulates on social media in aftermath of coup*. Available at: <https://www.euronews.com/my-europe/2020/08/19/mali-misinformation-circulates-on-social-media-in-aftermath-of-coup-thecube>
- [30] Howard, P. N., Duffy, A., Freelon, D., Hussain, M. M., Mari, W., & Maziad, M. (2011). *Opening closed regimes: what was the role of social media during the Arab Spring?*. Available at: SSRN 2595096.
- [31] Lotan, G., Graeff, E., Ananny, M., Gaffney, D., & Pearce, I. (2011). The Arab Spring| the revolutions were tweeted: Information flows during the 2011 Tunisian and Egyptian revolutions. *International journal of communication*, 5, 31.
- [32] Mascellino, A. (2022). *The best 6 encrypted messaging apps*. Available at: <https://www.androidpolice.com/best-encrypted-messaging-apps/>
- [33] The Hacker News. (2017). *75,000 Turks Arrested So Far for Downloading Encrypted Messaging App*. Available at: <https://thehackernews.com/2017/09/turkish-coup-bylock-messenger.html>

# Nexus between Intellectual Capital and Organizational Learning Capability

Matea Zlatković Radaković<sup>1</sup>

<sup>1</sup>Faculty of Economics University of Banja Luka, Banja Luka, Bosnia and Herzegovina

<sup>1</sup>matea.zlatkovic@ef.unibl.org

**Abstract**—Intellectual capital used to create and improve organizations' values and performance in knowledge-based economy greatly depends on its capability to successfully manage this scarce and rare resource. One of the key characteristics of organizations that enables knowledge creation and sharing to provide them with competitive advantage compared to others is the organizational capability to learn. The purpose of the study is to determine the significance and intensity of simultaneous effects of intellectual capital constructs as well as the significance of the relationship between intellectual capital and organizational learning capability. Research data obtained via a survey questionnaire are gathered from 224 organizations within different sectors from transition economy. Prior to delivering the questionnaire to organizations to collect data, pilot study was conducted to obtain feedback on the quality of the questionnaire items although measurement scales were adopted from previous studies. Latent constructs, proposed within research model, were measured with items measured on 7-point Likert-type scale ranging from "7=strongly agree" to "1=strongly disagree". Partial least squares structural equation modelling (PLS-SEM) is employed to test the proposed model and perform moderation analysis. These econometric techniques are utilized through SmartPLS software package, version 3.3.3. This study revealed that intellectual capital, mainly human and relational capital, have a positive and significant direct effect on organizational learning capability constructs.

**Keywords** – Intellectual capital, organizational learning capability, PLS-SEM

## I. INTRODUCTION

Current environment characterized by complexity, risks and growing stable and intensive competitors, increasingly changing

market and customers' needs demands from organizations to apply contemporary organization concepts and management approaches. Environmental complexity and dynamism force organizations to explore and ensure organizational structures that support two-way information and knowledge flows to encourage learning processes [1]. Organizational learning implies developing the most appropriate learning approach taking into consideration current organizational resources and capabilities simultaneously allowing new abilities and knowledge to be developed. Organizations need to continually upgrade their knowledge base and acquire new knowledge and information to respond to rapidly changing customer needs and nurture comprehensive approach to customers, stakeholders, suppliers, employees and competitor tendencies [2]. Focus on intangibles and knowledge sharing represents one dimension related to learning activities that provides long-term above-average performance, competitiveness and innovativeness [3]. As a key strategic resource, intellectual capital helps organizations to identify and quickly respond to changing customer needs and market opportunities. To support high-performance organizational achievement greater attention should be devoted to its cause-effect dynamics and simultaneous relations of intellectual capital and organizational learning. Organizations do not own capability to learn but they can acquire this capability based on the organizational members to share knowledge among themselves and to learn from other organizations and stakeholders such as customers, suppliers, and etc. [4]. Intellectual capital view and organizational learning capability approach could benefit from better understanding of environmental conditions by becoming more

context sensitive and providing practitioners directions for further development of the intellectual capital components and learning capabilities which have significant roles according to context peculiarities [5].

The purpose of this paper is to investigate the relationship between learning capabilities and intellectual capital resources of the organizations, and to identify significance and intensity of interrelations among intellectual capital constructs, using the partial least squares structural equation modelling (PLS-SEM) technique.

The paper is structured as follows. After introduction of the research problem and objective, following section contains literature review and research hypotheses. The research methodology comprised of sample structure, data collection process and measurement of variables is presented in Section 3. Section 4 contains performed data analysis and structural model results. Discussion of the obtained research findings is set out in Section 5. Implications for theory and practice, some limitations and recommendations for future research as well as conclusion remarks are presented in last section.

## II. LITERATURE REVIEW AND RESEARCH HYPOTHESES

### A. *Intellectual Capital - Definition and Structure*

Intellectual capital as one type of intangible resources have gained high attention in academic research and management practice worldwide. However, there is no consensus to its definition. Intellectual capital research field is still insufficiently developed due to its multidimensional nature [6]. As a multidimensional construct of assets of knowledge, practical capabilities and experience, intellectual capital improves organization's value [7]. It has some general dimensions such as human capital, structural capital and relational (customer) capital [8], widely used in the research field [9], as originally proposed by Bontis [10,11]. Although previous studies indicate lack of clear and precise intellectual capital conceptualization and definition, and classification system, majority of intellectual capital research followed by Bontis's intellectual capital classification [3,12]. Bontis's intellectual capital conceptualization and classification principle are also applied in this research.

Human capital represents a crucial component of intellectual capital and the most valuable source of sustainable competitiveness and organizational growth [12]. It is a knowledge base of each individual incorporated into organizational ability to cooperate to get the best possible solutions [10,11,13]. Human capital represents an asset that cannot be replaced by physical resources like machines or equipment [14,15].

Human capital lacks the support of infrastructure named structural capital [16]. It can be determined as non-human knowledge such as organizational charts, databases, process manuals, routines, strategies, which value exceeds any financial or material value. According to Bontis [10,13], the structural capital refers to mechanisms and organizational structures that support employees' pursuit towards optimal intellectual performance and thus overall performances. It includes strategies, routines, databases and process manuals. Structural capital contains efficiency elements, transaction times, procedural innovativeness and access to information for knowledge codification [10]. Structural capital is a critical link that allows the intellectual capital measurement at organizational level. Relational capital refers to intangible assets that help organizations to construct, sustain and control external relationships – those relationships among customer, suppliers, stakeholders and marketing channels. Relational capital contains knowledge gathered from all relationships with customers, stakeholders, partners in strategic alliances and other parties of the environment [17,18]. Based on these ties, organizations are able to perceive and better understand customer wants and needs and potential of target market [15,18].

The most applied intellectual capital interaction model is a diamond model where human capital represents the source of relational and structural capital [10]. This diamond model was modified – tested and partially or completely confirmed by many authors [17,19-23].

Various authors confirmed that human capital has a significant effect on structural capital [10,17,19-23]. Organizational success and ability to adapt to unpredictable market and changing customer needs depends on knowledge, competence and skills of their employees, which they take with themselves

when they live the organization. The following hypothesis is:

*Hypothesis 1: Human capital is positively related to structural capital.*

Previous research identified a significant effect of human on relational capital [10,17,19,22,23]. Higher relational capital rises cohesion among organizational members which helps them to cooperate to develop new ideas and obtain feedback information to enhance their creativity implying that relational and human capital are closely related **Error! Reference source not found.** The following hypothesis is:

*Hypothesis 2: Human capital is positively related to relational capital.*

Even though the human capital is the origin of intellectual capital through its influence on structural and relational capital, some authors provide evidence that structural and relational are mutual depended [17,21-23]. Many studies highlight that organizational settings are fundamental for creating and improving external relations because they provide knowledge sharing, identification and fulfilment of customer needs **Error! Reference source not found.** Thus, the following hypothesis is:

*Hypothesis 3: Relational capital is positively related to structural capital.*

#### *B. Organizational Learning Capability*

Organizational learning is important for organizational development and a source for competitiveness because it supports the arise of new and improvement of existing competencies [24]. Organizational learning helps organizations to cope with a rapidly changing environment. It represents the ability of organizations to develop their capabilities to obtain information and transform it into knowledge. Organizational learning development includes application of methods, structures and procedures that lead to creation of adequate surrounding for effective organizational learning [25].

Organizational learning is discussed in the literature in two different domains – as an outcome and/or as a process. Learning behavior, as one dimension of organizational learning reflects latter definition of the learning because it attempts to articulate behaviors through which outcomes could be achieved at organizational level. Some authors believe that learning

behavior should be interpreted as a continuous process in which theirs' members ask questions, discuss errors and unexpected results, seek for information, opportunities, test and reflect on the present assumptions and results and acquire feedback in general and from parties in cooperating networks [26]. However, learning behavior can lead to time waste, consequently, reducing organizational efficiency and overall performance. Also, organizational learning can be defined as set of values and beliefs that induce development of awareness and knowledge [27]. It can be described as organizational activities close to knowledge creation and exploitation [28]. Commitment to learning represents set of values that organizational learning is consisted of [29]. Commitment to learning deals with organizational orientation and motivation to learn [30]. This organizational value affects the probability that organization would promote learning culture. If organization assign very little value to learning practice than very little learning will happen [30]. Commitment to learning can be described as prerequisite to organizational capability to improve its comprehension of its environment. The cognitive framework of organizational learning is applied in this research.

#### *C. Intellectual Capital and Organizational Learning Capability Relationship*

Contemporary intellectual capital research stream tries to develop dynamic side of intellectual capital through its strong relations with dynamic organizational capabilities such as organizational learning perspectives. Organizational learning approach adds dynamics to organizational knowledge through learning flows that lead to understanding of intellectual capital as process of defining, integration, transforming, storing and renewing knowledge [11]. Previous researches indicated important role of intellectual capital in learning enhancement [31]. Some authors revealed the strongest connection between human capital and organizational learning capabilities, whereas others found that structural capital has the strongest influence [32]. Previous studies suggest that human and structural capital have effect on organizational learning capabilities with exception of third intellectual capital component – relational capital [1,32].

Organizational learning depends on the exchange and exploitation of the information,

knowledge and ideas used by employees. Highly qualified and skilled employees lead to greater generation of the knowledge which enhance organizational capability to learn. Therefore, the following hypothesis is:

*Hypothesis 4: Human capital is positively related to organizational learning capability.*

Employees will be able to disseminate more knowledge and information with other parties if organizations have developed systems, manuals and process for information communication and distribution [33]. Formalization and standardization of work and employees' knowledge influence their knowledge searching and sharing, learning modes and learning loops they apply at work place [34]. Previous studies have found that there was both significant and non-significant relationships between structural capital and organizational learning [32]. Therefore, the following hypothesis is:

*Hypothesis 5: Structural capital is positively related to organizational learning capability.*

Employees with wider social network are able to acquire and obtain more knowledge and information that could enforce organizational learning capabilities. The more relational capital organizations develop, the more likely it is to them to acquire knowledge from external parties to gain potential strategic benefit and to enhance further learning process [35]. Previous studies have found that there was both significant and non-significant relationships between relational capital and organizational learning [36]. The following hypothesis is:

*Hypothesis 6: Relational capital is positively related to organizational learning capability.*

### III. RESEACH METHODOLOGY

The objective of this research is to investigate the significance of the influence of the intellectual capital on the organizational learning capability. Thus, to test above mentioned hypotheses, the field research was conducted. All data are gathered via well-structured survey questionnaire delivered to organizations within different sectors by email or in person. At first, pilot study was performed to obtain feedback on quality of the questionnaire items and its content validity. With minor modifications of the certain items according to pilot group's recommendations, final version of the questionnaire was created. Latent constructs were measured with items

used from existing measurement scales with established content and convergent validity. Measurement items were measured on 7-point Likert-type scale ranging from "7 = strongly agree" to "1 = strongly disagree". Respondents as representatives of the organization were requested to indicate to what extent they agree or disagree with the survey items.

#### A. Intellectual Capital

Intellectual capital (IC) was measured using three latent constructs – human (HC) (20 items), relational (RC) (17 items) and structural capital (SC) (16 items). Measurement scales for these constructs were adapted from questionnaire developed and tested by Bontis [10,13]. Some items of the latent constructs of intellectual capital are reversed coded to improve scales validity and to encourage the respondents to read all items carefully rather than use a set pattern of responding [37].

#### B. Organizational Learning Capability

Organizational learning capability (OLC) was measured by two latent constructs, namely commitment to learning (CL) (4 items) and learning behavior (LB) (4 items). These measurement scales were adapted based on development scales tested by Baker and Sinkula, and Edmondson [26,38].

#### C. Sample and Data Collection Process

The final version of the questionnaire was sent to organizations in different sectors from Republic of Srpska, Bosnia and Herzegovina. Additional to the questionnaire, cover letter assuring complete anonymity of the respondents involved in the research was delivered. Survey questionnaire written in native language was sent to randomly chosen 500 organizations out of 3,838 organizations registered in the Business Register of Chamber of Commerce of Republic of Srpska, at the moment of accessing the database. The number of the organizations who actively participated in the survey by delivering fulfilled questionnaires was 243. After data cleansing to detect outliers, missing values and pattern responses, certain questionnaires were excluded to obtain quality input data for structural modelling technique application. The final sample size was 224 and these questionnaires were used for data analysis. The final sample consists of 84 product-oriented (38%) and 140 (62%) service-oriented organizations. Majority of the organizations are SMEs (88.39%) older than 15 years (63.39%).

The rule of thumb, for sample size, suggests that the number of observations should be 10 times more than there are arrows pointing into construct in measurement and/or structural model [39,40]. The measures of kurtosis and skewness are in range  $\pm 2$  suggesting indicating that there is no severe violation of data normality [41]. In line with the above-mentioned condition, 30 observations represent an acceptable sample size that is several times smaller than the real sample size of 224 organizations selected.

#### IV. DATA ANALYSIS AND RESULTS

According to results of statistic power analysis performed using G\*Power software package, version 3.1.9.2., using maximum 3 predictors of an endogenous construct in the proposed structural model, the minimum sample size of 55 observations is determined to achieve 80% statistical power, with probability error of 5%. To estimate the research model, partial least squares structural equation modelling (PLS-SEM) is used through the SmartPLS software package, version 3.3.3 [42]. Within

SEM, PLS path modelling is favored because the investigation of the mutual dependence of latent constructs and less rigorous assumptions. PLS-SEM analysis entails two-stage approach including measurement and structural model assessment [40,43-45].

#### A. Assessment of measurement and structural model

In the first stage of the PLS-SEM, indicators' reliability, constructs' internal consistency reliability, convergent validity and discriminant validity are examined and established. In the second stage, structural model assessment is conducted according to following criteria: multicollinearity issues ( $VIF < 1.715$ ), magnitude and significance of the path coefficients and predictive relevance analysis as shown in Fig.1.

The relationships between all intellectual capital constructs are significant. Results indicate that nearly all total effects of IC on OLC constructs are significant except SC on CL. Results of the assessment of the structural model are presented in Table 1.

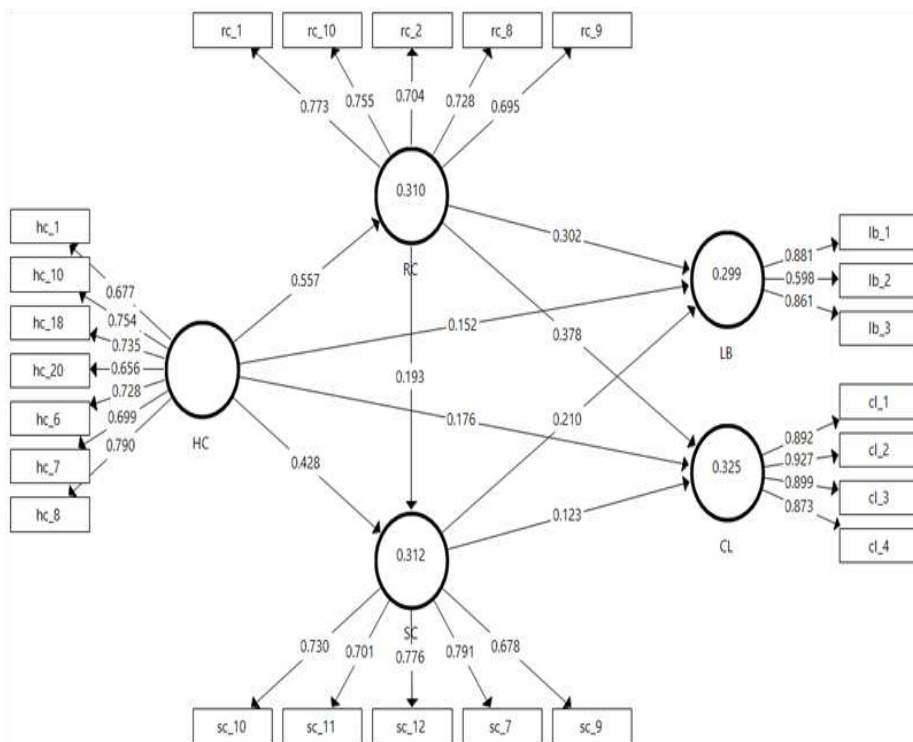

Figure 1. Direct effects and in-sample prediction results



TABLE I. PATH COEFFICIENTS, BOOTSTRAPPING PROCEDURE AND PREDICTIVE ACCURACY ANALYSIS

<b>Panel c<sub>1</sub>: Direct effects and their significance at 5% and 10% level</b>				
<i>Hypothesis</i>	<i>Direct effects</i>	<i>p values</i>	<i>BCa confidence intervals (95%)</i>	
			LB	UB
HC -> CL	0.176**	0.021	0.028	0.325
HC -> LB	0.152*	0.063	-0.009	0.317
HC -> RC	0.557**	0.000	0.440	0.643
HC -> SC	0.428**	0.000	0.274	0.553
RC -> CL	0.378**	0.000	0.239	0.523
RC -> LB	0.302**	0.000	0.156	0.442
RC -> SC	0.193**	0.017	0.041	0.358
SC -> CL	0.123 <sup>ns</sup>	0.131	-0.038	0.281
SC -> LB	0.210**	0.008	0.053	0.360
<b>Panel c<sub>2</sub>: Total effects and their significance at 5% and 10% level</b>				
<i>Hypothesis</i>	<i>Direct effects</i>	<i>p values</i>	<i>BCa confidence intervals (95%)</i>	
			LB	UB
HC -> CL	0.452**	0.000	0.342	0.546
HC -> LB	0.433**	0.000	0.302	0.533
HC -> RC	0.557**	0.000	0.440	0.643
HC -> SC	0.535**	0.000	0.427	0.623
RC -> CL	0.401**	0.000	0.259	0.547
RC -> LB	0.343**	0.000	0.190	0.488
RC -> SC	0.193**	0.017	0.041	0.358
SC -> CL	0.123 <sup>ns</sup>	0.131	-0.038	0.281
SC -> LB	0.210**	0.008	0.053	0.360

Note: LB-lower bound; UB-upper bound; bootstrapping procedure with 5,000 samples, two-tailed test, no sign change - \*\*p<0,05; \*p<0,10; ns - non significant; Source: author's calculations

## V. TESTING THE HYPOTHESES AND DISCUSSION

According to results of structural model evaluation presented in Table I, relationships between IC constructs are significant which is in line with results of previous studies [10,17,19-23]. HC has the strongest effect on RC meaning that managers need to fully exploit HC capacities to obtain market orientation toward customer wants, consequently, gaining and retaining their loyalty. The significant direct effect of HC on SC shows that organizations have developed capability to transform individual into organizational knowledge. Direct positive effect of RC on SC suggests that all organizations have significant investments in enhancing market orientation and are capable to successfully satisfy market needs. Thus, the hypotheses H1, H2 and H3 are confirmed.

All path coefficients between IC and OLC constructs are significant except SC on CL. All IC constructs have significant direct effects on the second OLC construct – LB. Obviously, RC and HC are crucial for increase of CL while RC and SC are important to enhance LB. Thus, the hypotheses H4 and H6 are completely confirmed while hypothesis H5 is partially confirmed. HC has the strongest effects on both OLC constructs – CL and LB mediated by RC, which is consistent with previous findings [32,33]. Greater HC indicates better cognitive skills and greater level of motivation of employees. Those organizations which invest more in development of HC attract knowledgeable and highly educated and skilled employees which further support learning practices improvement. Organizations support a claim that individual knowledge, skills and expertise together with well-developed quality social ties with customers and mutual trust provide effective knowledge transfer and value sharing [46]. It is important to emphasize that HC, through mediators such as RC and SC, has stronger effect on OLC. To build and enhance organizational learning practices it is not enough just to employ skilled and educated employees. Results showed that tacit knowledge embodied in employees together with external knowledge obtained from social relations and stored in knowledge repositories has stronger effect on development of organizational learning. RC has the strongest direct effects on OLC constructs. SC has a moderately significant effect on only one OLC construct named LB. These results are partially consistent with previous findings [32]. Without systems and procedures that provide relevant information for employees, the organization cannot learn [24].

## VI. CONCLUSION

### A. Implications for Theory and Practice

This research provides a deeper insight into the IC phenomenon by evaluating the relationship between widely used IC dimensions and OLC. Research findings are beneficial for both academic and business practice. Firstly, obtained results enrich existing OLC theories and IC research stream by conceptualizing and providing evidence on existence and magnitude of mutual relationships between different dimensions of IC and OLC. Second, the research contributes to existing literature in IC practice by providing empirical evidence on how effective IC management can improve various

aspects of OLC to sharpen the competitive edge and to enhance overall organizational value.

### B. Research limitation and recommendation

Firstly, this empirical testing of the proposed research is performed solely within one economy - The Republic of Srpska, Bosnia and Herzegovina. Thus, future cross-country empirical research is recommended. Second, research finding represent evidence at one point in time so future studies should be longitudinal, to capture growing OLC based on continuous IC development. Third, the sectoral structure of the selected sample together with a relatively small sample size does not representatively reflect the sector's size in the studied population. Fourth, solely perceptual measures to measure IC and OLC constructs are used in this research, even though, measurement scales were validated in more developed countries. Future studies could consider using combination of perceptual and objective measures to gain deeper insights into above-mentioned relationship. Further analysis should examine the presence of mediators of the IC - OLC relationship, such as environment or knowledge management. OLC concepts that include different types of learning skills and processes of learning should be taken into considered as well. Likewise, other concepts of IC such as renewal capital could enrich obtained findings. Moderation analysis using industry type, size and etc. as moderate variables could provide deeper insight into magnitude and significance of relationships between constructs of interest.

### REFERENCES

- [1] Durrah, O. M., Allil, K. K., & Alkhalaf, T. (2018). The intellectual capital and the learning organization. *International Journal of Public Leadership*.
- [2] Shamim, S., Cang, S., & Yu, H. (2017). Supervisory orientation, employee goal orientation, and knowledge management among front line hotel employees. *International Journal of Hospitality Management*, 62, 21-32.
- [3] Barrena-Martínez, J., Cricelli, L., Ferrándiz, E., Greco, M., & Grimaldi, M. (2020). Joint forces: Towards an integration of intellectual capital theory and the open innovation paradigm. *Journal of Business Research*, 112, 261-270.
- [4] Sun, R., Li, S., & Liu, W. (2020). A congruence perspective on how human and social capital affect learning capability and innovation. *PloS one*, 15(4), e0231504.
- [5] Whetten, D. A. (2009). An examination of the interface between context and theory applied to the study of Chinese organizations. *Management and organization review*, 5(1), 29-56.
- [6] Inkinen, H., Kianto, A., Vanhala, M., & Ritala, P. (2017). Structure of intellectual capital—an international comparison. *Accounting, Auditing & Accountability Journal*, 30(5), 1160-1183.
- [7] Rehman, S. U., Elrehail, H., Alsaad, A., & Bhatti, A. (2021). Intellectual capital and innovative performance: a mediation-moderation perspective. *Journal of Intellectual Capital*.
- [8] Wang, Z., Wang, N., Cao, J., & Ye, X. (2016). The impact of intellectual capital–knowledge management strategy fit on firm performance. *Management decision*, 54(8), 1861-1885.
- [9] Asiaei, K., Jusoh, R., & Bontis, N. (2018). Intellectual capital and performance measurement systems in Iran. *Journal of Intellectual Capital*, 19(2), 294-320.
- [10] Bontis, N. (1998). Intellectual capital – An exploratory study that develops measures and models. *Management Decision*, 36(2), 63-76.
- [11] Bontis, N. (1999). Managing organizational knowledge by diagnosing intellectual capital: Framing and advancing the state of the field. *International Journal of Technology Management*, 18(5/6/7/8), 433-462.
- [12] Oppong, G. K., & Pattanayak, J. K. (2019). Does investing in intellectual capital improve productivity? Panel evidence from commercial banks in India. *Borsa Istanbul Review*, 19(3), 219-227.
- [13] Bontis, N. (2001). Assessing knowledge assets: a review of the models used to measure intellectual capital. *International Journal of Management Reviews*, 3(1), 41-60.
- [14] Buenechea- Elberdin, M., Kianto, A., & Sáenz, J. (2018). Intellectual capital drivers of product and managerial innovation in high- tech and low- tech firms. *R&D Management*, 48(3), 290-307.
- [15] Na-Nan, K., Kanthong, S. N., Khummueng, K., & Dhienhirun, A. (2020). Intellectual capital of SMEs in Thailand: An employee behavioural measurement instrument. *International Journal of Organizational Analysis*, 29(4), 825-846.
- [16] Edvinsson, L., & Sullivan, P. (1996). Developing a model for managing intellectual capital. *European Management Journal*, 14(4), 356-364.
- [17] Cabrita, M. D. R., & Bontis, N. (2008). Intellectual capital and business performance in the Portuguese banking industry. *International Journal of Technology Management*, 43(1-3), 212-237.
- [18] Nakos, G., Dimitratos, P., & Elbanna, S. (2019). The mediating role of alliances in the international market orientation-performance relationship of smes. *International Business Review*, 28(3), 603-612.
- [19] Bontis, N., Keow, W. C., & Richardson, S. (2000). Intellectual capital and business performance in Malaysian industries. *Journal of Intellectual Capital*, 1(1), 85-100.
- [20] Tseng, C. Y., & James Goo, Y. J. (2005). Intellectual capital and corporate value in an emerging economy: empirical study of Taiwanese manufacturers. *R&D Management*, 35(2), 187-201.
- [21] Wang, W. Y., & Chang, C. (2005). Intellectual capital and performance in causal models: evidence from the information technology industry in Taiwan. *Journal of Intellectual Capital*, 6(2), 222-236.

- [22] F-Jardon, C. M., & Martos, M. S. (2009). Intellectual capital and performance in wood industries of Argentina. *Journal of Intellectual Capital*, 10(4), 600-616.
- [23] St-Pierre, J., & Audet, J. (2011). Intangible assets and performance: Analysis on manufacturing SMEs. *Journal of Intellectual Capital*, 12(2), 202-223.
- [24] Argote, L. (2013). Organization learning: A theoretical framework. In *Organizational learning* (pp. 31-56). Springer, Boston, MA.
- [25] Vallina, A. S., Moreno-Luzon, M. D., & Ferrer-Franco, A. (2019). The individual side of ambidexterity: Do inspirational leaders and organizational learning resolve the exploitation-exploration dilemma?. *Employee Relations: The International Journal*, 41(3), 592-613.
- [26] Edmondson, A. (1999). Psychological safety and learning behavior in work teams. *Administrative science quarterly*, 44(2), 350-383.
- [27] Tajeddini, K., Altinay, L., & Ratten, V. (2017). Service innovativeness and the structuring of organizations: The moderating roles of learning orientation and inter-functional coordination. *International Journal of Hospitality Management*, 65, 100-114.
- [28] Kumar, V., Jabarzadeh, Y., Jekhouni, P., & Garza-Reyes, J. A. (2020). Learning orientation and innovation performance: the mediating role of operations strategy and supply chain integration. *Supply Chain Management: An International Journal*, 25(4), 457-474.
- [29] Jyoti, J., & Dev, M. (2015). The impact of transformational leadership on employee creativity: the role of learning orientation. *Journal of Asia Business Studies*, 9(1), 78-98.
- [30] Sinkula, J. M., Baker, W. E., & Noordewier, T. (1997). A framework for market-based organizational learning: Linking values, knowledge, and behavior. *Journal of the academy of Marketing Science*, 25(4), 305-318.
- [31] Alnidawi, A. A. B., & Omran, F. M. (2016). Learning organization impact on internal intellectual capital risks: an empirical study in the Jordanian pharmaceutical industry companies. *International Business Research*, 9(10), 176-185.
- [32] Moghadam, S. K., Zabihi, M. R., Kargar, M., & Hakimzadeh, A. (2013). Intellectual Capital and organizational learning capability. *Journal of Soft Computing and Applications*, 2013, 1-9.
- [33] Hsu, Y. A., & Fang, W. (2009). Intellectual capital and new product development performance: The mediating role of organizational learning capability, *Technological Forecasting & Social Change*, 76(5), 664-677.
- [34] Sitar, A. S., & Škerlavaj, M. (2018). Learning-structure fit part I: Conceptualizing the relationship between organizational structure and employee learning. *The Learning Organization*, 25(5), 294-304.
- [35] Chahal, H., & Bakshi, P. (2015). Examining intellectual capital and competitive advantage relationship: Role of innovation and organizational learning. *International Journal of Bank Marketing*, 33(3), 376-399.
- [36] Akhtar, S., Awan, S. H., Ismail, K., & Naveed, S. (2017). Social capital and learning organisation: is it worth to engage in networking?. *International Journal Of Learning And Change*, 9(3), 208-227.
- [37] Weijters, B., & Baumgartner, H. (2012). Misresponse to reversed and negated items in surveys: A review. *Journal of Marketing Research*, 49(5), 737-747.
- [38] Baker, W. E., & Sinkula, J. M. (1999). The synergistic effect of market orientation and learning orientation on organizational performance. *Journal of the academy of marketing science*, 27(4), 411-427.
- [39] Bagozzi, R. P. and Yi, Y. (2012), "Specification, evaluation, and interpretation of structural Equation Model", *Journal of the Academy of Marketing Science*, 40(1), 8-34.
- [40] Hair, J.F., Sarstedt, M., Ringle, C.M. and Gudergan, S.P. (2018), *Advanced issues in partial least squares structural equation modeling (PLS-SEM)*, Sage Publications, Thousand Oaks.
- [41] Gravetter, F., & Wallnau, L. (2012). *Statistics for Behavioral Sciences*. Belmont, CA: Wadsworth Cengage Learning.
- [42] Ringle, C.M., Wende, S. and Becker, J.M. (2015), *Smart PLS 3*, SmartPLS GmbH, Boenningstedt.
- [43] Tenenhaus, M., Esposito Vinzi, V., Chatelin, Y.-M., & Lauro, C. (2005). PLS path modeling. *Computational Statistics & Data Analysis*, 48(1), 159-205.
- [44] Henseler, J., Ringle, C. M., & Sarstedt, M. (2016). Testing measurement invariance of composites using partial least squares. *International Marketing Review*, 33(3), 405-431.
- [45] Sarstedt, M., Ringle, C. M., Smith, D., Reams, R., & Hair, J. F. (2014). Partial least squares structural equation modeling (PLS-SEM): A useful tool for family business researchers. *Journal of Family Business Strategy*, 5(1), 105-115.
- [46] Uzzi, B., & Lancaster, R. (2003). Relational embeddedness and learning: The case of bank loan managers and their clients. *Management science*, 49(4), 383-399.

# Choice of Methodology for Management IoT Project

Maja Gaborov<sup>1</sup>, Jelena Grujić<sup>2</sup>, Dragana Kovač<sup>3</sup>, Mila Kavalić<sup>4</sup>, Stefan Ugrinov<sup>5</sup>

<sup>1,3,4,5</sup>Technical Faculty “Mihajlo Pupin”, Zrenjanin, Serbia

<sup>2</sup>Faculty of Philosophy, University of Belgrade, Belgrade, Serbia

<sup>1</sup>majagaborov26@gmail.com, <sup>2</sup>grj0107@gmail.com, <sup>3</sup>dragana.milosavljev@tfzr.rs,

<sup>4</sup>milazakin@gmail.com, <sup>5</sup>stefanugrinov1@gmail.com

**Abstract**—The reason for the failure of Internet of Things (IoT) projects may be the lack of specific project management methodologies that adequately address the complexity of IoT projects. For the application of IoT solutions, there are approaches to software development such as Scrum and Kanban, and others are adapted to large-scale Scrum, Scaled Agile Framework, etc. This study compares the main characteristics of different IoT methodologies. The comparison presented in this paper would be useful in selecting the appropriate methodology for IoT projects. In addition, it identifies their strengths and limitations in order to propose a new approved IoT methodology. It is crucial that each methodology is applied depending on the nature of the project.

**Keywords** - IoT, project, methodology, management

## I. INTRODUCTION

The Internet of Things (IoT) is a new computing paradigm [1,2], which describes several technologies such as RFID, short-range wireless communications, and research disciplines that can connect real-world physical objects to the Internet [2-4]. It has emerged as an important technology with applications in many areas. Most IoT devices are connected together to form purpose-specific systems. They are rarely used as general access devices on the World Wide Web [5].

Approaches to software development for implementing IoT solutions, such as Scrum and Kanban, have encountered many problems due to the nature of IoT projects that have led to the emergence of custom methodologies such as the Scaled Agile Framework (SAFe) [2,6]. Agile methodologies are popular in the software

industry [7]. Agile methodologies [7,8] have revolutionized the software industry and provided frameworks, such as Scrum and extreme programming, etc., to enable fast delivery of working software to clients [7,9,10].

The aim of this paper is to present the project management methodology and to determine which is the best to use.

## II. RESEARCH OF METHODOLOGY

### A. Subject and problem of research

Like any project, an IoT project should have an appropriate methodology to be applied in management. However, it is necessary to know which methodology should be applied, and that will mostly depend on the type of work, the needs of the clients and the like. It is necessary to notice the characteristics of each methodology in order to best choose the appropriate one.

### B. Research Question

RQ: Which methodology is most applied in IoT projects?

### C. Research Goal

As already mentioned, the aim of this study is to present an overview of the main characteristics of all methodologies applied in IoT project management and to identify which is most applied in practice.

## III. THEORETICAL CONSIDERATION

The literature review provides a brief description of IoT and IoT projects, as well as a methodology for managing these projects.

### A. Internet of Things

The Internet of Things is defined as “a dynamic global network infrastructure with self-configuration capabilities based on standard and interoperable communication protocols” [11]. The new paradigm is in the software and hardware industry and imagines a global network of devices interconnected using Internet technology or a specific protocol such as User Datagram Protocol (UDP) or Transmission control protocol (TCP). The strength of IOT technology lies in the ability to connect to devices that are also integrated into business processes such as vending machines, business intelligence applications or customer supply systems that facilitate business processes and the like [12]. Such “things” can generally be defined as smart objects and if supported by “anywhere, anytime and anything” [3], they are the basic building blocks for IoT [4,13].

### B. IoT Projects

“IoT projects can be categorized as high technology with an extremely dynamic product development lifecycle” [14]. Due to the large number of failed IoT projects, an appropriate project management philosophy is needed, based on which there would be greater flexibility, agility, teamwork and the development of a strong technical framework [15].

According to a 2017 Cisco survey, about 75% of IoT projects have a negative impact on several industries that feel less secure in investing in IoT business because it is considered a risky business [12,16]. Project management is built around a system development lifecycle, with waterfall or agile methodologies playing an important role in defining, designing, developing, testing, and then applying the end product. Longer project deadlines, comprehensive testing, strict compliance, planning and security rules, requiring a review of management planning can be expected in IoT projects. Cisco research highlighted one of the main causes of IoT project failure, the “human factor”. and these include poor technical or managerial skills, lack of communication, or overall culture. The lack of accepted and recognized technical and management “jargon” causes interoperability problems when it comes to managing IoT projects [12,17]. IoT projects have longer project deadlines, and testing time is longer than in other ordinary technical projects [12,18]. New project management styles are needed because risk is

involved in different stages of product development, compliance and security risk is different compared to other software and hardware projects [12,18]. Projects should be managed differently from traditional IT projects, hardware or software. The five phases (collection, transport, storage, analysis and archiving of the IoT project) should be harmonized with the current phases of the project management project, i.e. with the launch, planning, execution, monitoring and control and closure [19]. The project manager should be involved in the research and development phase of the IoT project [20]. In Amazon’s drone delivery (IoT) project, managers would be involved from the research and development phase, going through the entire process of managing and developing the way drones communicate with air traffic controllers, the corporate office and end-customer product delivery. “The need to involve IoT project managers in technical issues would be the fact that the number of jobs for managers will decrease in the future, while jobs for qualified people will increase” [21]. Sensory data will help companies reduce downtime, save money, increase productivity and help determine the amount of manpower needed. Project managers should expect longer on-site work [22]. To lead a successful IoT project, the manager needs to have a plan B to plan better risk management that facilitates the replacement or updating of IoT components and ultimately purchases from the entire organization [12,23].

Some of the approaches in project management are: Kanban, Agile, Disciplined Agile Delivery, Scrum, Extreme Programming and various Agile methodologies to adapt to products based on Big Data, SOA (Service Oriented Architecture) and IoT products [12]. The impact of these approaches on IoT projects has been poorly studied due to lack of data over time, so it remains uncertain which of these strategies are better for IoT projects. According to the Vikram Prasher study [12] in 2018, managers in IoT firms prefer an agile methodology and a hybrid of waterfalls and agile functions in IoT-based projects [12,15,24]. In IoT project organizations, workforce agility plays a vital role in determining the agility of organizations. Workforce agility is the ability of employees to adapt and develop and to offer innovative solutions and a quick turnaround and to demonstrate sufficient skills of employees at any stage of project/program execution as

needed. Employees need to show speed, innovation, flexibility, cooperation, adaptability, competence and a progressive attitude. Management plays an important role by providing appropriate training, empowerment, promoting teamwork, better compensation and a world-class information system [25].

IoT projects must be managed differently from simple and traditional IT, production or construction projects [48].

### C. Methodologies of IoT Projects

The concept of agile methodology became important in 2001 when the Manifesto for the Development of Agile Software was published [26]. One study reveals that agile methodologies were completely new in the way they were articulated and consolidated in a theoretical context [27]. The agile methodology was created with the aim of reducing the risks of previous software development methods, such as intensive documentation and inefficiency until they appear on the market [28]. There has been a general struggle against such inefficiencies in software development methods [29]. Agile methodologies emerged when efforts to meet customer requirements for contracted products and services underwent unexpected changes. This phenomenon arose as a result of increased business competitiveness [30]. The introduction of agile concepts has led customers to appreciate the speed of products and services, as well as efforts to reduce costs in software development [31]. Suppliers intend to make higher profits at lower costs, and the predictable deadline for completion of the project was relative [32]. It is estimated that 46% of small and medium enterprises have applied a number of agile methodologies.

The project team should always follow a methodology that helps it satisfy the customer. Based on the 13th annual report on the state of agility [2,34] which shows that Scrum (54%) and Kanban (5%) are the most common agile methods used by organizations, in addition, SAFe (30%) dominates in scaling methodologies. Some authors choose Ignite|IoT methodology and IoT methodology because the first methods were created in IoT organizations especially for IoT projects [2]. There are methods for managing IoT projects that have emerged due to the evolution of technology and the need for methods to adapt to this type of project [35,36]. "IoT methodology is an iterative methodology inspired by lean startup and design

thinking" [2,13,37]. IoT methodology is a generic, lightweight method built on iterative prototyping and lean startup approaches. There are presented illustrates the steps of IoT-Meth, eliminating its iterative nature for the sake of simplicity. IoT-Meth involves the following iterative steps [5]: Generate ideas, refine ideas, conceptualize a project, design an architecture, prototype a proof of concept, deploy IoT system. Ignite is an open source methodology based on real experience that covers all aspects of IoT development. It includes two main parts. The first part, entitled "Strategy Implementation", which defined the IoT strategy and prepared the organization for the adoption of the IoT, then created and managed a portfolio of IoT projects to support the IoT strategy. The second is "solution delivery", which has implemented the planning, construction and launch of IoT solutions [2]. Ignite|IoT methodology is "Big Method" invented in the industry based on the best practices of industrial projects [35,36,38]. Ignite|The IoT methodology is intended for a variety of IoT stakeholders, including product managers, project managers, and solution architects. It has two large groups of activities: Execution of IoT strategy and Delivery of IoT solution. The implementation of the IoT strategy aims to define the IoT strategy and the portfolio of projects that support this strategy. IoT Solution Delivers supports IoT solution design and IoT project management, along with some artifacts, such as project templates, checklists, and solution architecture designs. The implementation of the IoT strategy refers to the business perspective and includes the identification of opportunities, the development of a business model and decision-making on how to manage those opportunities. IoT solution delivery refers to the delivery of a solution, which is conceptually defined during the implementation phase of the IoT strategy and has a life cycle consisting of planning, construction and operation of the system. Planning begins with the launch of the project, in which the initial design of the solution and the scheme of the project organization are submitted. It is necessary to conduct an analysis of actors, environment, requirements, risks and resources. Once launched, tasks are managed in seven workflows: project management, cross-cutting tasks, infrastructure solutions and operations, back-end services, communication services, component assets, and property preparation. Project management includes activities to initiate, plan, execute, monitor, control, and close

a project. Multiple tasks solve dependencies among future workflows, such as security and testing. Infrastructure operations and solutions include the installation and management of the hardware and software infrastructure on which the IoT system will be developed and operated. Background services refer to IoT services that are typically hosted on a private or public cloud and communicate with IoT devices. Communication services include the installation and management of communication infrastructure. Asset components refer to the development or procurement of software and the production or procurement of hardware and network components that need to be integrated with things in the IoT system. Asset preparation deals with the production and procurement of items in the IoT system [5].

Scrum was developed to help team members understand how to work on flexible system manufacturing in an ever-changing environment. This approach is easy to implement [2,39,40,41]. It is a good way to introduce an agile approach to project management because it is simple and easy to handle by the whole team involved in the project. It is a management framework for the gradual development of products using one or more cross-functional, self-organizing teams of seven people each. Short iterations are called Sprints and have a fixed length that does not exceed 30 days, but they are usually kept as short as possible. The idea of Sprint is for teams to try to increase the products that can be released at the end of the Sprint. Scrum uses only three roles in software management, namely Product Owner, Scrum Master and Development Team. The owner of the product has a leading role. He is responsible for creating and downloading the request by approving the final version. It constantly reorganizes the remaining products to adapt the software to customer requirements. It can decide on the date of publication and agreements or in the process of ongoing development and is responsible for maximizing returns to development efforts [42]. Scrum Master allows you to monitor the SCRUM process and follow all the steps accordingly. Filters external messages / interventions so that SCRUM flow is not interrupted or delayed. He is responsible for resolving obstacles that arise in the process. The development team is composed of 6 to 9 members. He plans one Sprint at a time with the product owner. In order to implement SCRUM, the roles that manage the software must communicate and collaborate throughout

the software development process, so that the software is fully maintained and monitored until it is released to the end user. A sprint planning meeting is held at the beginning of each sprint. At the meeting, the product owner and development team negotiate which product backlog items can fit in Sprint where the key is to choose the scope of work that the development team will try to complete in order to eventually deliver something functional to Sprint. A daily Scrum meeting is held every day and should not exceed 15 minutes. The main purpose is for each member to present the progress of the work and, if possible, the work planned for that day. Obstacles to completing the work will also be presented during the meeting. The main purpose of the meeting is for the team to collaborate, communicate and create a strong and organized team [42]. The customer can always request even more software functions, new hardware, etc. One of the first advantages that can be noticed is that Agile has iterative developmental stages. The main Agile artifacts are structured as can be seen below in Fig.1 [33].

There is a product backlog written by the product owner and multiple sprints. The obligatory process is the Daily Scrum, which is presented above in a small circle with “24 hours” in it. At the end of each sprint, the end customer is delivered as a result to confirm all completed work items. This “demo session” is also a mandatory artifact of the Agile process. Based on this iterative process, even on a detailed level, Daily Scrum helps to discern some obvious advantages of choosing Agile for IoT projects. Considering the periodic demo sessions during the Agile implementation, it can be seen from an early stage why the waterfall delivery may lack useful exposure to the client [33].

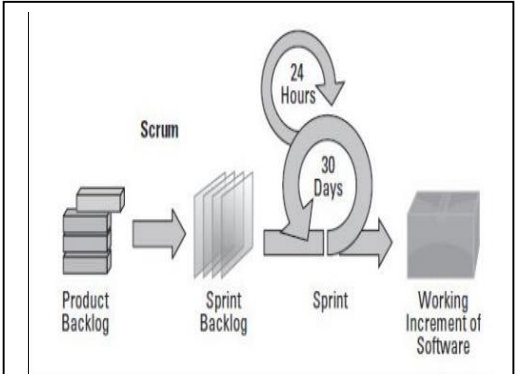

Figure 1. Agile Scrum main artefacts used for Software Development Life Cycle [33]

The term “Kanban” means “signboard”. It is an extremely flexible method that required an explicit definition of process policies. The key is to the success of the software product by applying six principles which are Visual Workflow Display, Workflow Restriction, Workflow Management, Explicit Processes/Policies, Implementation of Feedback Loops, Improving Collaboration. Kanban is designed to help teams work together effectively [2,39,43,44].

SAFe comes to solve problems related to the development and delivery of software and systems in the shortest time. It is based on agile development, Systems thinking and Lean product development [2,46,47]. It focuses on nine Lean-Agile principles such as take an economic view; apply systems thinking; assume variability, preserve options; build incrementally, with fast integrated learning cycles and so on [2,45,47].

#### IV. RELATED WORK

In one paper, a case study was conducted among four selected small and medium enterprises that developed the Internet of Things application as their business core. The results revealed that all companies studied use extreme programming (KSP), dynamic system development methodology (DSDM), feature-based development (FDD) and Lean as the chosen development methodology. The most used agile framework of the methodology are the Scrum techniques. The study shows that companies used Agile SDM. This is because Agile SDM helps development teams to efficiently organize their tasks and can deliver them frequently to their stakeholders and users [30].

Second paper has a structured case study around a home automation project, which is relevant when the authors try to highlight the advantages of an agile approach compared to other delivery methods such as waterfall, V-model and so on. The selected Agile methodology presented in this paper is the most popular (Agile Scrum) [33].

#### V. DISCUSSION AND CONCLUSION

Several studies show that the scrum method is still the most used because it delivers products in short cycles, allows for quick feedback and quick adaptation to change. It does not accept more than one team and is not designed to

support large, highly distributed projects. Kanban makes a profit earlier than Scrum and accepts changes every time, not like Scrum accepts changes after a sprint. Agile people are developing new methodologies based on existing ones, such as the Scaled Agile Framework (SAFe), which supports small solutions that employ 50-125 practitioners, as well as complex systems that require thousands of people. It is considered too difficult and complex. IoT projects are divided into two parts, software and hardware. However, Scrum and SAFe are for software, not hardware, which makes it difficult to use them in this type of project. IoT project teams have proposed their own methodologies based on their research and experience, such as Ignite|IoT methodologies and IoT methodology. These are the first two methods designed for the IoT domain. Ignite Cover all aspects of the IoT project and build on the real experience. Also, the stronger side of the IoT methodology is the use of IoT Canvas and IoT OSI references. Ignite is limited to executing strategies and delivering solutions and reuses various existing generic practices, combining them with innovative practices specifically for IoT, in a way that makes it difficult to reuse and share new practices. They are not a complete method that covers all the important phases necessary for the development of an IoT system. Due to the increased expectations of end users from connected devices, companies need to develop frequent updates, upgrades and an efficient user experience. Implementing any new function in an IoT project may require customizing the hardware and software behind the project and this may affect the strategy behind the entire project. Therefore, there is a need to adapt to the project and select an appropriate management methodology that is well equipped to deal with the requirements of connected devices, where frequent updates are essentially a requirement.

Some of the methodologies are Scrum, Kanban, SAFe, IoT methodology, Ignite | The IoT methodology etc. It is important to say that each methodology has its pros and cons. The answer to the research question would be that each methodology has its advantages and disadvantages and that the methodology depends on the nature of the project. Based on the search of various literature, scientific papers and journals, it can be concluded that Scrum is the most widely used. In the future, research could be done on the territory of Serbia to see which methodology is most applied and in which way.



## REFERENCES

- [1] Krotov, V. (2017). The Internet of Things and new business opportunities. *Business Horizons*, 60(6), 831-841.
- [2] Merzouk, S., Cherkaoui, A., Marzak, A., & Nawal, S. (2020). IoT methodologies: comparative study. *Procedia Computer Science*, 175, 585-590.
- [3] Feki, M. A., Kawsar, F., Boussard, M., & Trappeniers, L. (2013). The internet of things: the next technological revolution. *Computer*, 46(2), 24-25.
- [4] Elhadi, S., Marzak, A., Sael, N., & Merzouk, S. (2018). Comparative study of IoT protocols. *Smart Application and Data Analysis for Smart Cities (SADASC'18)*.
- [5] Giray, G., Tekinerdogan, B., & Tüzün, E. (2017). IoT system development methods. In *Internet of Things* (pp. 141-159). Chapman and Hall/CRC.
- [6] Slama, D., Puhmann, F., Morrish, J., & Bhatnagar, R. M. (2015). *Enterprise IoT: Strategies and Best practices for connected products and services.* O'Reilly Media, Inc."
- [7] Sachdeva, V., & Chung, L. (2017, January). Handling non-functional requirements for big data and IOT projects in Scrum. In *2017 7th International Conference on Cloud Computing, Data Science & Engineering-Confluence* (pp. 216-221). IEEE.
- [8] Highsmith, J., & Cockburn, A. (2001). Agile software development: The business of innovation. *Computer*, 34(9), 120-127.
- [9] Abrahamsson, P., Warsta, J., Siponen, M. T., & Ronkainen, J. (2003, May). New directions on agile methods: a comparative analysis. In *25th International Conference on Software Engineering, 2003. Proceedings.* (pp. 244-254). Ieee.
- [10] Beck, K. (1999). Embracing Change with Extreme Programming. *Computer* (revista de la IEEE Computer Society), 32(10), 70-77.
- [11] Ghimire, S., Luis-Ferreira, F., Nodehi, T., & Jardim-Goncalves, R. (2017). IoT based situational awareness framework for real-time project management. *International Journal of Computer Integrated Manufacturing*, 30(1), 74-83.
- [12] Hurtoi, V., & Avadanei, D. (2020). IoT Project Management. *Informatica Economica*, 24(3), 75-80.
- [13] Collins, T. (2017). A methodology for building the Internet of Things. Retrieved August, 21, 2021.
- [14] Patil, M., & Suresh, M. (2019). Modelling the enablers of workforce agility in IoT projects: a TISM approach. *Global Journal of Flexible Systems Management*, 20, 157-175.
- [15] Prasher, V. S. (2018). Internet of things (iot) and changing face of project management.
- [16] Johansen, C., Culp, B., & Mora, M. (2017). Cisco survey reveals close to three-fourths of IoT projects are failing. *CISCO, San Jose, CA, USA*.
- [17] Dijkman, R. M., Sprengels, B., Peeters, T., & Janssen, A. (2015). Business models for the Internet of Things. *International Journal of Information Management*, 35(6), 672-678.
- [18] Scroxton, A. (2016). Enterprise IoT projects will be costly, lengthy and vulnerable, says Gartner, available at: <https://www.computerweekly.com/news/45002708/31/Enterprise-IoT-projects-will-be-costly-lengthy-and-vulnerable-says-Gartner>.
- [19] Bekker, M. (2017). The five phases of an IoT project.
- [20] Curlee, W. Episode 337: Internet of Things (IoT) Projects may Fundamentally Change Project Management. (C. Fichtner, Interviewer), available at: <https://www.mixcloud.com/theprojectmanagementpodcast/episode-337-internetof-things-iot-projects-may-fundamentally-change-projectmanagement-free-p>.
- [21] <http://www.psginc.com/how-internet-of-things-iot-relates-with-project-management/>, 2016.
- [22] Newman, D. (2018). Disrupting Project Management with the IoT.
- [23] Buntz, B. (2016). How Not to Manage an IoT Project: 7 Common Pitfalls.
- [24] Prasher, V. S. (2018). Internet of things (iot) and changing face of project management.
- [25] Patil, M., & Suresh, M. (2019). Modelling the enablers of workforce agility in IoT projects: a TISM approach. *Global Journal of Flexible Systems Management*, 20(2), 157-175.
- [26] "What is Agile Software Development?|Agile Alliance." Available: <https://www.agilealliance.org/agile101/>. [Accessed: 15- Dec2017].
- [27] Williams, L., & Cockburn, A. (2003). Agile software development: It's about feedback and change. *Computer*, 36(6), 39-43.
- [28] Jalali, S., Wohlin, C., & Angelis, L. (2014). Investigating the applicability of agility assessment surveys: A case study. *Journal of Systems and Software*, 98, 172-190.
- [29] James, A. (2002). *Agile software development ecosystems*. Addison-Wesley Professional.
- [30] Jusoh, Y. Y., Abdullah, S., Ali, I. M., Noh, M. H. M., Mazlan, M. H., Bouh, C. S., & Sheng, T. Z. (2019, December). Adoption of agile software methodology among the SMEs developing an IOT applications. In *2019 6th International Conference on Research and Innovation in Information Systems (ICRIIS)* (pp. 1-6). IEEE.
- [31] Dybå, T., & Dingsøyr, T. (2008). Empirical studies of agile software development: A systematic review. *Information and software technology*, 50(9-10), 833-859.
- [32] Madadipouy, K. (2015). An Examination and Evaluation of Agile Methodologies for Systems Development. *Australas. J. Comput. Sci.*, 2(1), 1-17.
- [33] Fireteanu, V. V. (2020, June). Agile methodology advantages when delivering internet of things projects. In *2020 12th International Conference on Electronics, Computers and Artificial Intelligence (ECAI)* (pp. 1-5). IEEE.
- [34] VersionOne and CollabNet. The 13th annual State of Agile report. (2018). Available: [stateofagile.com](http://stateofagile.com)
- [35] Merzouk, S., Cherkaoui, A., Guerres, F. Z., Marzak, A., & Nawal, S. (2021). Smart Irrigation: case study for Hybrid-SIX methodology. *Procedia Computer Science*, 191, 524-529.
- [36] Merzouk, S., Cherkaoui, A., Marzak, A., & Nawal, S. (2020). IoT methodologies: comparative study. *Procedia Computer Science*, 175, 585-590.
- [37] <http://www.iotmethodology.com/>.

- [38] Jacobson, I., Spence, I., & Ng, P. W. (2017). Is There a Single Method for the Internet of Things? Essence can keep software development for the IoT from becoming unwieldy. *Queue*, 15(3), 25-51.
- [39] Merzouk, S., Elhadi, S., Cherkaoui, A., Marzak, A., & Sael, N. Agile software development: comparative study. *SSRN Electron. J.*(2018).
- [40] Despa, M. L. (2014). Comparative study on software development methodologies. *Database Systems Journal*, 5(3), 37-56.
- [41] Schwaber, K., & Sutherland, J. (2010). The Scrum papers: Nut, bolts, and origins of an Agile Framework. *SCRUM Inc*, 224..
- [42] Gal, A., Filip, I., & Dragan, F. (2018). A new vision over Agile project management in the internet of things era. *Procedia-Social and Behavioral Sciences*, 238, 277-285.
- [43] Flora, H. K., & Chande, S. V. (2014). A systematic study on agile software development methodologies and practices. *International Journal of Computer Science and Information Technologies*, 5(3), 3626-3637.
- [44] Anderson, D. J. (2010). *Kanban: successful evolutionary change for your technology business*. Blue Hole Press.
- [45] “What is SAFe|Scaled Agile.” <https://www.scaledagile.com/enterprise-solutions/wh-at-is-safe/>.
- [46] Jacobson, I. *SAFe Principles*. Ivar Jacobson International, Jun. 29, 2017. <https://www.ivarjacobson.com/publications/blog/safeprinciples>
- [47] Ebert, C., & Paasivaara, M. (2017). Scaling agile. *Ieee Software*, 34(6), 98-103.
- [48] Prasher, V. S., & Onu, S. (2020). The Internet of Things (IoT) upheaval: overcoming management challenges. *The Journal of Modern Project Management*, 8(2).



# Consumer Behavior and its Influences in 2022

Lenka Veselovská<sup>1</sup>

<sup>1</sup>Matej Bel University, Faculty of Economics, Institute of Managerial Systems,  
Poprad, Slovak Republic

<sup>1</sup>lenka.veselovska@umb.sk

**Abstract**—Consumer behavior is a complex system that is influenced by various factors. Many of such determinants are well-known, however, other factors remain a mystery. This research strives to uncover the factors that have influenced consumers in the first half of 2022. Empirical study was selected as a main method of research. Sample file consisted of consumers from Slovak Republic. The findings of this study relate to measuring the continuing influence of the COVID-19 pandemic and also other external influences such as extreme increase in inflation and armed conflict in Ukraine. It was discovered that the pandemic still had a major effect on consumers, however, the impacts of inflation have become to increase and it is likely that in the near future this will be the most important factor influencing consumer behavior.

**Keywords** - consumer behavior, pandemic, inflation, war

## I. INTRODUCTION

Consumer behavior is generally understood as a response of a person to a set of external and internal stimuli that results in interest shown to product and which often also leads to its purchase [1]. Researchers have dedicated a lot of attention to discovering what these stimuli are. It was discovered that it is necessary to divide these factors into two main groups – the internal and the external factors. There are further divisions within these categories [2]. Many authors covered the options for measuring the influence of such determinants of consumer behavior that can provide a clear image at the current state of affairs in society [3,4].

However, the influence of these factors evolves dynamically. That presents an ever-

lasting research gap that needs to be filled continuously in order to correctly understand the current business reality. Therefore, this research strives to explore what factors had a major influence on consumer behavior in the first half of year 2022. Due to the short time period there was a lack of publically available data on this issue. Because of this reason the empirical research was selected as the main research method and the data was collected directly from the consumers providing a comprehensive image of consumers' opinions.

## II. LITERATURE REVIEW

Reference [2] explored the set of factors that influence all consumers. They can be divided into four groups with subgroups existing in each category. Cultural factors are commonly based on consumer's nationality, education, religion, social status and so on. Group of social factors includes the influences of family, friends, colleagues and other close acquaintances. Remarkable is also the influence of reference groups the consumer either belongs to or strives to a member of. Consumer behavior is often influenced by an individual's personal characteristics. By personality we understand a set of different psychological traits that lead to relatively consistent and permanent reactions to environmental stimuli. Personality is often described using such character traits as self-confidence, dominance, independence, compliance, sociability, caution or adaptability. Personality can be a useful variable especially when analyzing consumer behavior and its potential changes [5]. Human needs are unlimited. If they are strong or urgent enough, they can result in motives for action. These motives represent psychological factors

influencing consumer behavior. A motivated person is ready to act. How such a person will actually act is influenced by his perception of a particular situation. Perception is the process by which a person selects, organizes, and interprets incoming information to form a meaningful picture of the world. Perception depends not only on physical stimuli, but also on their relationship to the surrounding environment and on the inner state of the individual [2,6]. People can perceive the same object differently due to three processes: selective attention, selective distortion, and selective recall [4]. This makes psychological factors extremely difficult to measure.

There have been many research studies focused on discovering the factors influencing consumer behavior and even measuring their effects [7-9]. References [10] and [11] researched specifically the influence of COVID-19 pandemic on consumers' purchasing decisions. These authors concluded that pandemic significantly changed how consumers make their purchasing decisions. They also described a newly formed trend related to consumers' preferred form of shopping and newly emerged factors influencing their behavior such feeling of safety in stores and accessibility of shops. Reference [4] also discovered a link between pandemic and psychological factors. References [12] and [13] found out that there were significant changes in levels of social responsibility presented by specific groups of consumers during the pandemic implying a newly forming trend towards more responsible consumers who are willing to take the time and effort to learn basic information on products they consider buying and decide accordingly. Reference [14] reached a similar conclusion. Reference [15] proved that systems approach can be quite valuable in terms of exploring such a complex issue as consumer behavior. This approach was applied during a research related to discovering consumer behavior changes during the COVID-19 pandemic [16,17] that served as a baseline for this research.

### III. METHODOLOGY

This research relates to previous studies into consumer behavior; however, it adopts a new approach to explore the influences of specific factors on consumer behavior in 2022. Empirical research was selected as a main method of data collection and evaluation.

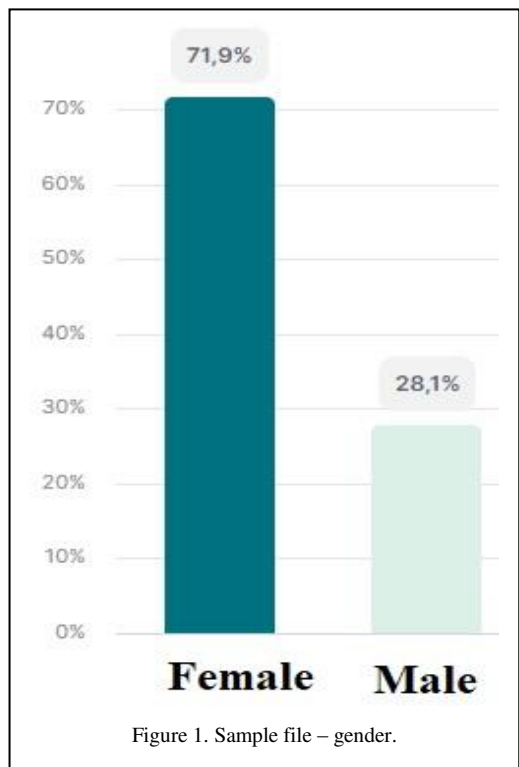

Questionnaire was prepared and distributed in order to discover the influences of selected factors. Consumers were selected randomly to ensure anonymity of research and to increase the return of completed questionnaires. Data were collected during the period of May – October 2022. Research sample file consisted of consumers from Slovak republic. Fig.1 provides information on gender structure of sample file. This research was carried out on a sample that consists of consumers that were the main buyer of daily consumption goods in their households, therefore, the data show that the vast majority of them in 2022 were women.

Furthermore, the Fig.2 shows the age structure of sample file represented by the year of birth. The majority of consumers in sample file were born after year 1995 (34.5%), which makes them 27 years old or younger.

### IV. RESULTS

The main aim of this research was to uncover the factors that have influenced consumers in first half of 2022. It was discovered that the majority of consumers was still concerned by the pandemic, its impacts on business environment and also the related risks (93.7% of consumers). However, 73.5% of Slovak consumers declared that they were less

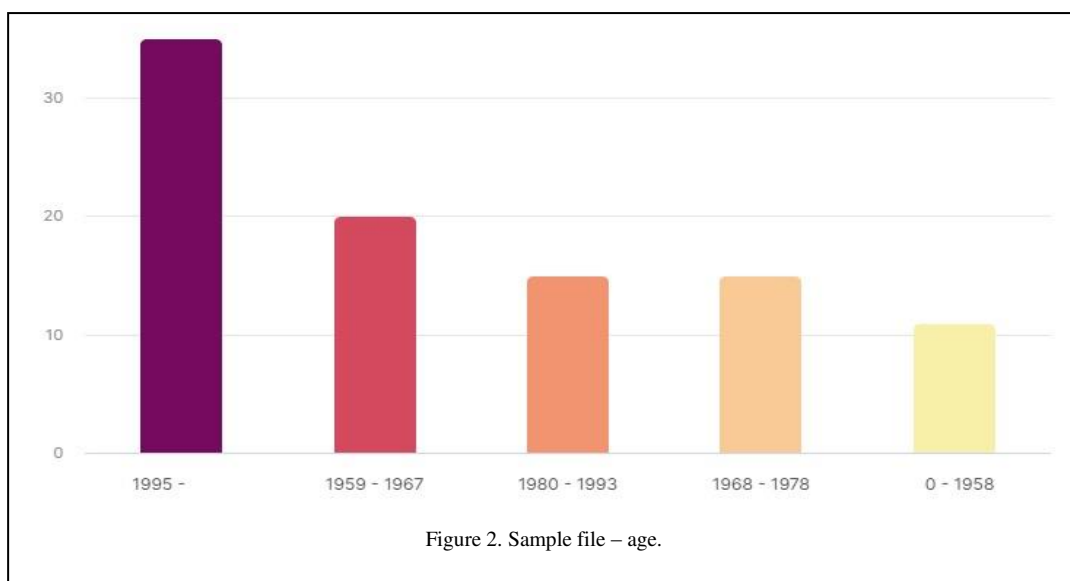

Figure 2. Sample file – age.

focused on gathering information on pandemic than they had been in 2021. This research covers the continued influence of pandemic since we assumed that this would be the major factor influencing consumer behavior in 2022. However, other external factors specifically related to Slovak consumers were chosen for this research.

The first explored issue was related to new factors that influenced consumers in 2022. Consumers were presented with a list of 10 factors including national and international threats and opportunities related to current situation in Slovak Republic. They were also presented with an option to add additional determinants if needed, however, no consumers provided an answer. Therefore, we assume that provided options were satisfactory and broad enough to cover the main factors influencing consumer behavior in the first half of year 2022. Consequently, the research focused on factors that at least 3% of interviewed consumers

marked as important for them. Three factors pass this minimal limit – COVID-19 pandemic, inflation and war in Ukraine. The issue of governmental disputes among the politicians was near the borderline, however, it was still selected only by 2.45% of consumers, and therefore, this factor was used not in further more detailed research. Only the first three major determinants of consumer behavior were evaluated in more detail.

The research focused on exploring how consumers from different households perceive the new or continuing external influences on their consumer behavior. The data in Table I show the differences in importance of three main factors.

It was discovered that the armed conflict in neighboring Ukraine had little influence on consumers and their purchasing decisions. However, the inflation has become the major source of influence since more than half of interviewed consumers had taken price rising

TABLE I. FACTORS INFLUENCING CONSUMER BEHAVIOR IN 2022 BASED ON HOUSEHOLD STRUCTURE (IN % OF CONSUMERS).

Household situation	Factors		
	<i>pandemic of COVID-19 disease</i>	<i>price rise (inflation)</i>	<i>war in Ukraine</i>
living alone	53.33	46.67	0.00
living with parents	33.33	63.33	3.33
living with partner without children	52.38	38.10	4.76
living with partner with children	45.16	48.39	6.45
<b>Total</b>	<b>44.79</b>	<b>51.04</b>	<b>4.17</b>

under consideration in first half of the year 2022. Since the true effects of inflation have only started to show in the beginning of 2022, it is safe to assume that its influence on consumer behavior will only in second half of 2022 and in increase in near future. The pandemic has remained a major factor influencing consumers even in 2022 when its effects on life in societies have significantly diminished. However, nearly half of consumers were still affected by fear of the disease and related restrictions imposed by Slovak government such as the obligation to prove oneself with a test and/or vaccination or the obligation to cover the upper respiratory tract with face mask. Surprisingly, it was the consumers who lived with their parents who stated the pandemic as factor with the least frequency. On the other hand, consumers who either lived alone or with partner and children marked the pandemic as the main factor influencing their choices in 2022. The inflation was mostly by consumers living with parents.

There were some interesting variances observed in the measure of influence of these factors on consumers of different gender as shown in Fig.3. Women were more concerned by the pandemic than men. On the other hand, men showed more focus on war in Ukraine as a major factor influencing their consumer behavior. However, the increasing rate of inflation was the main determinant of behavior of consumers regardless of their gender.

All of the consumers who were influenced by the war in Ukraine have completed university education. On the other hand, the majority of consumers affected by the inflation as the main determinant of their consumer behavior, finished only elementary school. Level of education is always related to income; therefore, it was expected that people with

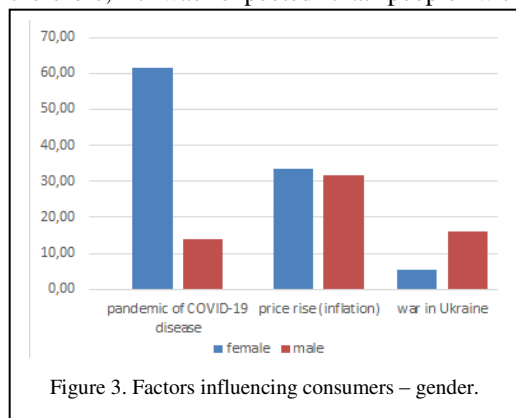

lower income would be more impacted by rising inflation rates. On the other hand, people who attended university or college are more inclined to pay attention to non-economic issues such as social problems or health threats, even the issue that do not concern them directly such as situation in other countries. Furthermore, these consumers are more socially sensitive, and they expand their own ideas on social issues to their shopping habits.

Data on major external factors influencing consumer behavior in 2022 clearly indicate that there are differences within consumer segments based on their age, gender, household situation and even level of education. The biggest differences were observed when the findings on factors were structured by gender. The only exception was the rising rates of inflation. It seems that this factor impact men and women almost equally. On the other hand, the smallest differences were observed in segments structuring related to age of consumers. There were almost no notable differences in perception of analyzed external factors with the exception being the COVID-19 pandemic. The younger consumers were less concerned by its prevailing influences than consumers born before the year 1993.

## V. CONCLUSIONS

The aim of this research was to discover the major factors influencing consumers in Slovak Republic in 2022. The findings of empirical research on a sample of Slovak consumers indicate a prevailing influence of the pandemic on consumer behavior, however, it was discovered that the main determinant was the rising rates of inflation which influenced 51.04% of consumers. However, the influence of COVID-19 pandemic on decisions of consumers remained almost equally important. Even though the impacts of the pandemic on life in societies declined significantly in 2022 in comparison to previous two years, 44.79% of consumers still remained influenced by this factors. Therefore, it can be concluded that the pandemic remains fresh in minds of consumers and its influence will disappear gradually, but progress will be slow. On the other hand, the influence of inflation and war in neighboring Ukraine will probably increase in second half of year 2022 and even further in the future until other major disruptions appear in society. This research also proves that factors influencing consumer behavior are a dynamically evolving

set of determinants whose influence can change quickly, however, the effects of such factor prevail often long after the initial shock that had caused it. The findings of this research and other research studies on this topic [17-21] prove that the influence of COVID-19 pandemic is one of such determinants with long lasting effects. Therefore, more research on its influences is still needed in order to understand the nature of pandemic's consequences in business environment.

Findings of this research can be useful for companies in business practice that can create their marketing activities according to the needs and expectations of consumers. In the near past a lot of activities were related to pandemic, especially the marketing campaigns. However, this trend seems to be on decline. Therefore, companies should focus more on the inflation that is currently the dominant factor influencing consumer behavior. Furthermore, we aim to stimulate the further research into topic, therefore the findings can serve as a guideline for other researchers.

#### ACKNOWLEDGMENT

This contribution was supported by the project No. 1/0134/22, "Changes in consumer behavior due to the COVID-19 pandemic with intent to predict its development".

#### REFERENCES

- [1] Akila, M., & Ramesh, K. (2021). A Study on Consumer Behaviour Towards Purchase of Selected Instant Packed Food Products in Cuddalore District Tamil Nadu. *Bioscience biotechnology research communication*, 14(6), 344-348.
- [2] Veiga, P. M., & Diogo, J. (2022). Consumer Behavior: A Literature Review of the Early Research on the COVID-19 Outbreak. *International journal of marketing communication and new media*, 11, 62-91.
- [3] Kotler, P., & Keller, K. L. (2013). *Marketing management*. Grada Publishing.
- [4] Di Crosta, A. et al. (2021). Psychological factors and consumer behavior during the COVID-19 pandemic. *Plus One*, 16(8).
- [5] Snyder, H., Witell, L., Gustafsson, A., & McColl-Kennedy, J. R. (2022). Consumer lying behavior in service encounters. *Journal of business research*, 141, 755-769.
- [6] Migliore, G., Rizzo, G., Schifani, G., Quatrosi, G., Vetri, L., & Testa, R. (2021). Ethnocentrism effects on consumers' behavior during COVID-19 pandemic. *Economies*, 9(4).
- [7] Moon, J., Choe, Y., & Song, H. (2021). Determinants of consumers' online/offline shopping behaviours during the COVID-19 pandemic. *International journal of environmental research and public health*, 18(4).
- [8] Boca, G. D. (2021). Factors Influencing Consumer Behavior in Sustainable Fruit and Vegetable Consumption in Maramures County, Romania. *Sustainability*, 13(4).
- [9] Hakami, N. A., & Mahmoud, H. A. H. (2022). The Prediction of Consumer Behavior from Social Media Activities. *Behavioral sciences*, 12(8).
- [10] Bausch, C. L., Milan, G. S., Graciola, A. P., Eberle, L., & Bebbler, S. (2021). The COVID-19 pandemic and the changes in consumer habits and behavior. *Gestao e desenvolvimento*, 18(3), 3-25.
- [11] Yin, B. B., Yu, Y. J., & Xu, X. C. (2021). Recent advances in consumer behavior theory: shocks from the COVID-19 pandemic. *Behavioral sciences*, 11(12).
- [12] Rathore, P., Saha, E., Chakraborty, S., & Tiwari, A. K. (2022). Assessing impact of consumer perceived CSR on consumer attitude and purchase behaviour in retail segment: a stakeholder theory perspective. *Society and business review*.
- [13] Lee, C. K., Mousa, F. T., Lee, J., & Lee, S. H. (2021). Consumer behaviour and social entrepreneurship: the case of South Korea. *Journal of social entrepreneurship*.
- [14] Pacho, F. T., & Batra, M. M. (2021). Factors influencing consumers' behaviour towards organic food purchase in Denmark and Tanzania. *Studies in agricultural economics*, 123(2), 62-75.
- [15] Hudáková, L. (2013). System approach and system analysis and their application in management. In *Proceedings of the international conference Current state and perspectives of enterprises' development in conditions of international economic activity (pp. 170-179)*.
- [16] Prymon-Rys, E., & Galarowicz, A. (2021). Buying behaviors of polish consumers during the pandemic lockdown - research results. *Problemy zarzadzania-Management issues*, 19(4), 19-37.
- [17] Veselovska, L., Zavadsky, J., & Bartkova, L. (2021). Consumer behaviour changes during times of the COVID-19 pandemic: an empirical study on slovak consumers. *E & M Ekonomie a management*, 24(2), 136-152.
- [18] McAleer, M. (2020). Prevention Is Better Than the Cure: Risk Management of COVID-19. *Journal of Risk and Financial Management*, 13(3), 46.
- [19] Ning, L., & Wang, Y.Q. (2020). Quantitative analysis of the COVID-19 pandemic shock to household consumption in China. *Frontiers of Economics in China*, 15(3), 355-379.
- [20] Vázquez-Martínez, U. J., Morales-Mediano, J., & Leal-Rodríguez, A. L. (2021). The impact of the COVID-19 crisis on consumer purchasing motivation and behavior. *European Research on Management and Business Economics*, 27(3), 100166.
- [21] Bartková, L. (2019). How do consumers perceive the dual quality of goods and its economic aspects in the European Union? An empirical study. *Problems and perspectives in Management*, 17(3), 382-394.





# Investigating Digital Divide in European Rural Areas as a Barrier to Knowledge Sharing

Anđelka Stojanović<sup>1</sup>, Aleksandra Radić<sup>2</sup>, Sanela Arsić<sup>3</sup>, Isidora Milošević<sup>4</sup>

<sup>1,2,3,4</sup>University of Belgrade, Technical Faculty in Bor, Bor, Serbia

<sup>1</sup>anstojanovic@tfbor.bg.ac.rs, <sup>2</sup>aradic@tfbor.bg.ac.rs, <sup>3</sup>saarsic@tfbor.bg.ac.rs,

<sup>4</sup>imilosevic@tfbor.bg.ac.rs

**Abstract**—The challenge of a digital society is to be knowledge-intensive, based on information, digitalization, a smart economy and knowledge sharing. However, every society faces equalities and inequalities in terms of education, skills and knowledge about the acceptance of information and communication technologies. The digital divide is a phenomenon that arises precisely due to differences in the approach and way of using digital technologies. Especially the digital divide occurs in the domain of rural and urban areas. Therefore, the paper aims to examine the digital divide in European countries and determine the level of digital development in countries in rural areas. The EDAS multi-criteria method was used to classify European countries in relation to elements of digitalization in rural areas. The study's results indicate the degree of the digital divide in European countries.

**Keywords** - digital divide, rural areas, EDAS

## I. INTRODUCTION

Acquiring and sharing knowledge and information is the main power of the present and future times. The ability of an individual or group to become economically and socially successful is based precisely on the ability to acquire knowledge and the necessary information. Digitization is a revolution that is happening and bringing changes to all aspects of life and business. Therefore, countries, companies and individuals cannot win the competitive race unless they embrace information and communication technologies (ICT). Sharma and associates state that the challenge of a society that tends to be

knowledge-intensive is multidimensional and based on the information and knowledge economy [1]. Also, they underlined ICT as one of the pillars of a knowledge society [1]. In every society, despite the continuous development of information and communication technologies, not everyone has the same opportunity to access these technologies. Also, differences can be observed regarding the level of knowledge, skills and education, yet resistance to accepting information and communication technologies. The digital divide is a term that describes differences in approaches and ways of using digital technologies. Certain countries or parts of society show a superior ability to adapt to changes, mainly based on knowledge as a resource. On the other hand, some parts of society are significantly behind in this race. The discrepancy between countries caused the lagging in terms of investments in ICTs, PC users' skills and Internet users' skills [2]. Whether it is a lack of infrastructure, finances or skills and competencies, individuals, groups, and even entire countries fail to keep up with the changes that are taking place. In this regard, the rapid growth of the ICTs industry, the gap in countries' economies and social inequality result in the emergence of a digital divide [3,4].

Rural areas represent a large part of the territory of Europe, but they also represent areas with pronounced negative demographic characteristics [5]. For example, there are more fiber optic communication systems in the European continent than in some other continents. However, different ICT access and

acceptance levels can be noticed in different areas in the same country [6].

Therefore, the paper aims to analyze levels of digital development in rural areas and estimate the digital divide in European countries. For that purpose, several evaluation criteria were used that are in line with different authors who used various criteria for considering the digital divide. According to some authors, fixed and mobile broadband were used as determinants of the digital divide in rural and urban areas [7,8]. One of the digital divide indicators is also an economic factor that causes the inability to use computers or mobile phones to access the Internet [9,10]. E-government represents a set of services that enable interaction between citizens, companies and public authorities based on modern ICTs technologies [11]. It is an important tool for enabling better access to health care, education or other public services [9]. In addition, another criterion which could be included implies financial activities refer to individuals who have made some financial transaction through online services offered by banks [12].

In accordance with the above, it could be stated that the digital divide is an important topic with several dimensions. Therefore, measuring the digital divide between countries can be analyzed by the mean of a wide range of criteria.

## II. THEORETICAL BACKGROUND

The digital divide was established as a term in the 1990s [13] to describe the perceived growing gap between those who have access and those who have limited (or no access at all) and skills for using ICTs [2]. The OECD defines the digital divide as the gap between individuals, households, businesses and geographical areas at different socio-economic levels with regard to both opportunities to access ICT and use of the Internet for a wide variety of activities [14]. According to Hsieh the digital divide is defined as a digitally cognitive difference between Internet users and individuals who do not have the technical abilities to access Internet technologies [3]. All those definitions of the digital divide have the same main components: (1) it is determined by access to ICTs, (2) it refers to individuals, households or different areas (rural or urban) and (3) this term includes a gap between more and less developed countries.

Digitization is seen as a potential to overcome the gap between urban and rural areas. Therefore, the United Nations emphasizes that ICTs can be used as an excellent way for knowledge sharing, skills improvement, and providing electronic services in underdeveloped areas [15,16]. However, the population in rural areas is getting older, and the number of inhabitants is constantly decreasing [17,18]. Moreover, many rural areas face a lack of essential infrastructure elements (absence of broadband coverage, poor roads, isolated households, inaccessible terrain) [19,20]. Public institutions, educational institutions and large businesses mostly associate their functioning with urban environments, even when the purpose of their business is related to the rural areas (faculties of agriculture, companies engaged in food production and processing, centers for innovation and development of agriculture, etc.). Opportunities to start and succeed in business are also limited in rural areas due to the distance between buyers, suppliers and market access. Morris and associates especially emphasized the influence of low connectivity in rural areas on business activity [21]. Tiwasing and associates mention connectivity, low level of digital skills of the workforce and cyber vulnerabilities as the most significant challenges for rural businesses in the digital era [22]. As a result, companies are unable to pursue diversified activities, which limits their ability to grow and develop resilience during economically challenging times.

By adding digitalization to the problems of rural areas mentioned earlier, the gap between rural and urban areas has only deepened. As a result, the population that remains in rural areas is at greater risk of falling into the category of marginalized social groups, while in urban areas, the use of ICT among the population is experiencing expansion. Consequently, the success of digitization adoption in a society is measured by the level of people's participation in economic development through the use of ICT. Therefore, the goal of every state administration is to reach out to those social groups that remain outside the current digital changes and to make an influence in diminishing existing gap constantly.

Digital technology transfer from urban to rural environments should be implemented through three phases. The first stage of the integration of digital technologies is the

provision of adequate infrastructure. Digital infrastructure means providing broadband coverage and devices required for Internet access [23]. This is a fundamental and necessary prerequisite for overcoming digital inequality in rural areas. The consequences of the rural digital divide on the rural population's economy and social status are significant [24]. Recently the great attention of policymakers and broadband suppliers has focused on overcoming this gap. The next stage is the acceptance of ICT by the rural population. The lack of broadband access furthermore limits the acceptance of digital technologies [25]. But, when the problems of connectivity are overcome, as has been done to a large extent in recent years, it is necessary to work on the adoption of ICT by the rural population, as well as on their training in the use of ICT [26]. The resistance that occurs may be a consequence of the demographic characteristics of the rural population, such as gender, ageing and migration. Another reason for the profound resistance to the acceptance of ICT is the lack of knowledge and skills for the adequate use of ICT [27]. Studies found that young people who used the Internet at school and home developed higher computer and Internet skills and showed better academic performances later and more increased preparedness for a knowledge society. Also, research showed digital skill differences even in the case of children living in rural areas compared with urban ones [28]. The third phase is the creation of appropriate content for the rural population. The contents and services offered via the Internet often do not meet the needs of the rural population and are not adapted to their level of understanding. Digital financial inclusion presupposes a combination of ICT and finance by providing a wide range of digital services which are more efficient and less costly [29]. Nevertheless, the authors Niu and associates conclude that for the full utilization of digital technologies for financial inclusion, it is necessary to increase the effective adoption of financial activities through more targeted and adapted activities, especially for residents of rural areas who have a lower level of digital skills and financial experience [29]. Also, e-government initiatives are largely unexploited, especially in rural areas. Although significant efforts and means are being made to reduce the digital divide by enabling access to public services through ICT, some of the main challenges, according to Sharma and associates

are a lack of digital literacy in rural areas and low awareness of e-government services [30].

Based on the literature review, it can be concluded that the level of rural digital development is assessed by achievements in all three mentioned phases [25,29,30]. The indicators of the digital level must contain information about fixed and mobile broadband and devices used for Internet access to evaluate the success of the first phase of digitalization. For the second phase, the intensity of Internet use by individuals in rural areas, who have access to the Internet, and the use of online services, such as purchasing and searching for necessary information, should be assessed. Finally, as the highest level of digital technologies implementation, the involvement in activities that enable the realization of economic and social rights, such as financial activities and e-government services, must be evaluated. In this sense, the adaptation of Internet content to the rural population's needs is assumed in order to achieve inclusion in modern society.

### III. METHODOLOGY

According to the literature [2,3,31], there is increasing interest in researching the digital divide, especially in the domain of rural and urban areas. For that purpose, a lot of Multiple Criteria Decision Making (MCDM) methods were used. Chang and associates generated five dimensions (including ICTs infrastructure, human resources, external environment, the internals of the organization, and information) and 42 measures for the digital divide using the Analytic Hierarchy Process (AHP) [32]. Banihashemi and Rejaei used the Technique for Order of Preference by Similarity to Ideal Solution (TOPSIS) for ranking Asia countries in domain of the digital divide through several criteria [33]. Bahnamiri and associates applied the Fuzzy TOPSIS technique for ranking countries in terms of the ICT Development Index (IDI) taking in consideration 69 countries and 11 criteria [34]. According to this, it can be said that there is possibility for applying MCDM techniques in the domain of investigating the digital divide among countries.

In this paper, the Evaluation Based on Distance from Average Solution (EDAS) method was used to compare the levels of digital development in rural areas between countries. The EDAS method was developed by Keshavarz and associates [35,36]. It is based on

determining the distance alternatives have in relation to the average solution, whereby alternatives are finally ranked according to the decreasing values of the appraisal scores. The best-ranked alternatives should have the highest PDA value and the lowest NDA value. The EDAS method is a relatively new method that researchers use, mainly when multicriteria models consist of incompatible and conflicting criteria [37,38]. The steps for applying EDAS methods are presented in Fig.1.

In the model proposed in this research, alternatives are represented by 32 European countries for which data are available in the Eurostat database. The study did not consider certain countries of Eastern Europe because

there is no data on digital-level indicators measured at the level of settlement type in the EUROSTAT database [39].

The criteria are represented by previously determined indicators of the digital level. These criteria are linked to the digital level as beneficial criteria in the model. The weights of the criteria are equally distributed in order to perform the ranking of the countries. Initial data in the ranking process are presented in Table I.

It is possible to perform a ranking based on the obtained AS values for each country. The rank of countries and AS values are presented in Table II.

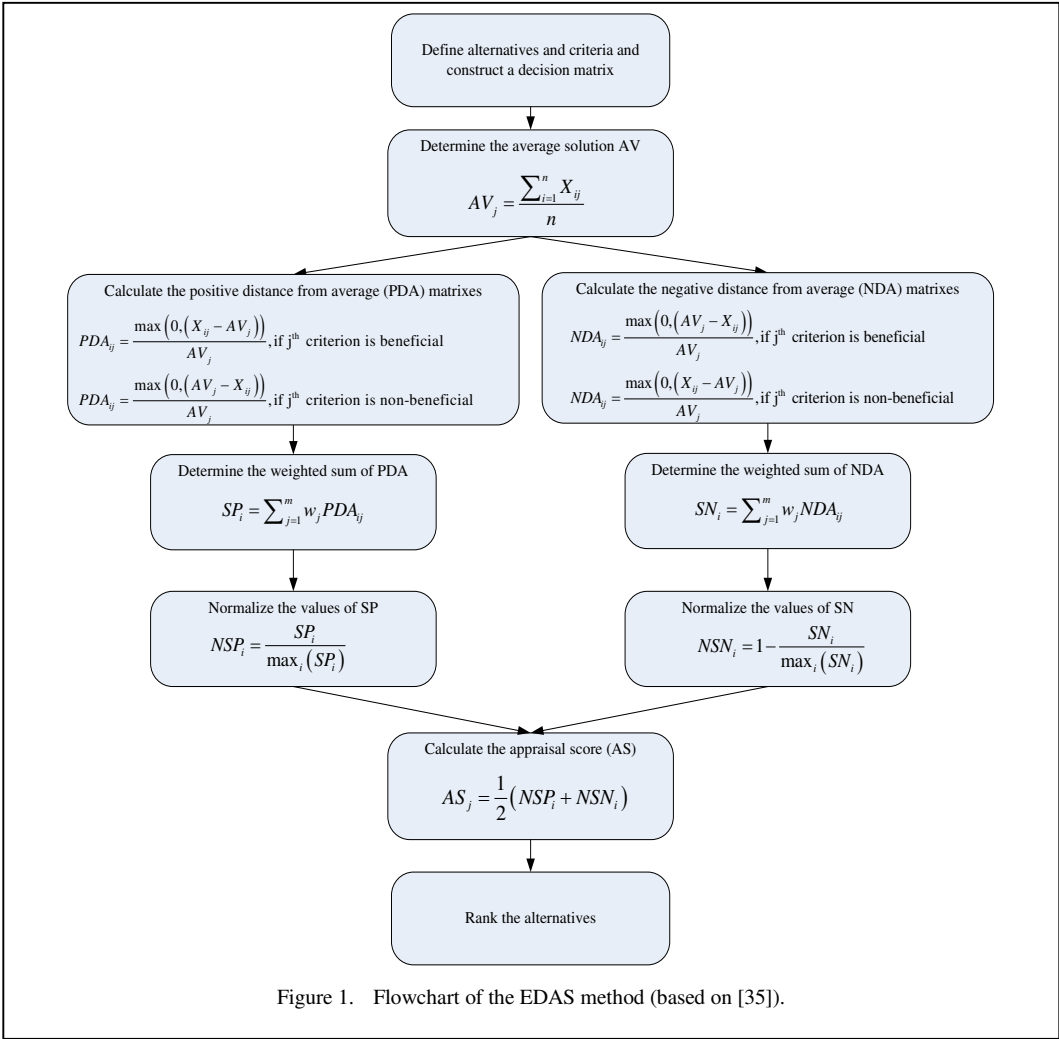

Figure 1. Flowchart of the EDAS method (based on [35]).

TABLE I. INITIAL DATA FOR RANKING COUNTRIES USING EDAS.

	Fixed broadband	Mobile broadband	Use desktop computer	Use mobile phone	Internet use	Internet purchases	Financial activities	E-government activities
Austria	68	66	41	84	85	51	7	70
Belgium	80	33	34	81	90	57	11	59
Bulgaria	42	53	17	63	55	9	5	25
Croatia	65	50	67	67	73	33	4	33
Cyprus	79	3	19	85	80	24	2	50
Czech	68	29	41	73	84	37	12	54
Denmark	84	41	30	88	96	70	19	92
Estonia	80	77	31	76	89	53	52	80
Finland	48	87	32	86	92	50	34	87
France	62	38	38	75	89	57	10	75
Germany	87	66	35	74	92	71	18	59
Greece	61	20	20	60	62	27	3	52
Hungary	74	65	24	73	74	31	8	53
Iceland	92	52	47	95	99	62	46	89
Ireland	69	44	31	92	89	54	33	61
Italy	54	40	34	74	72	26	6	23
Latvia	50	46	33	76	83	27	28	70
Lithuania	57	49	21	77	76	32	14	55
Luxembourg	90	45	46	87	95	64	12	60
Malta	59	33	31	67	65	50	7	50
Netherlands	98	49	47	91	97	68	37	81
N. Macedonia	61	60	25	78	77	18	1	25
Norway	88	68	34	95	98	64	43	87
Poland	55	52	20	75	74	33	2	40
Portugal	61	38	27	68	64	21	7	41
Romania	51	50	14	75	66	12	1	12
Slovakia	67	39	28	76	79	42	8	59
Slovenia	77	79	40	83	78	41	7	53
Spain	62	68	26	91	86	42	7	58
Sweden	85	59	34	91	96	69	40	86
Switzerland	87	76	47	96	95	72	17	75
UK	94	61	na	na	91	76	51	63

TABLE II. THE RANK OF COUNTRIES BASED ON DIGITAL LEVEL IN RURAL AREAS.

Rank	Country	AS <sub>i</sub>	Rank	Country	AS <sub>i</sub>
1	Iceland	1.000	17	Belgium	0.475
2	Norway	0.957	18	Spain	0.430
3	Estonia	0.927	19	Croatia	0.385
4	Netherlands	0.923	20	Czechia	0.382
5	Sweden	0.907	21	Hungary	0.349
6	Switzerland	0.820	22	Slovakia	0.345
7	Finland	0.784	23	Lithuania	0.327
8	Denmark	0.688	24	Malta	0.281
9	United Kingdom	0.673	25	Poland	0.191
10	Germany	0.670	26	Italy	0.181
11	Ireland	0.657	27	Portugal	0.171
12	Luxembourg	0.625	28	North Macedonia	0.166
13	Austria	0.541	29	Cyprus	0.124
14	Slovenia	0.505	30	Greece	0.088
15	Latvia	0.496	31	Bulgaria	0.017
16	France	0.487	32	Romania	0.000

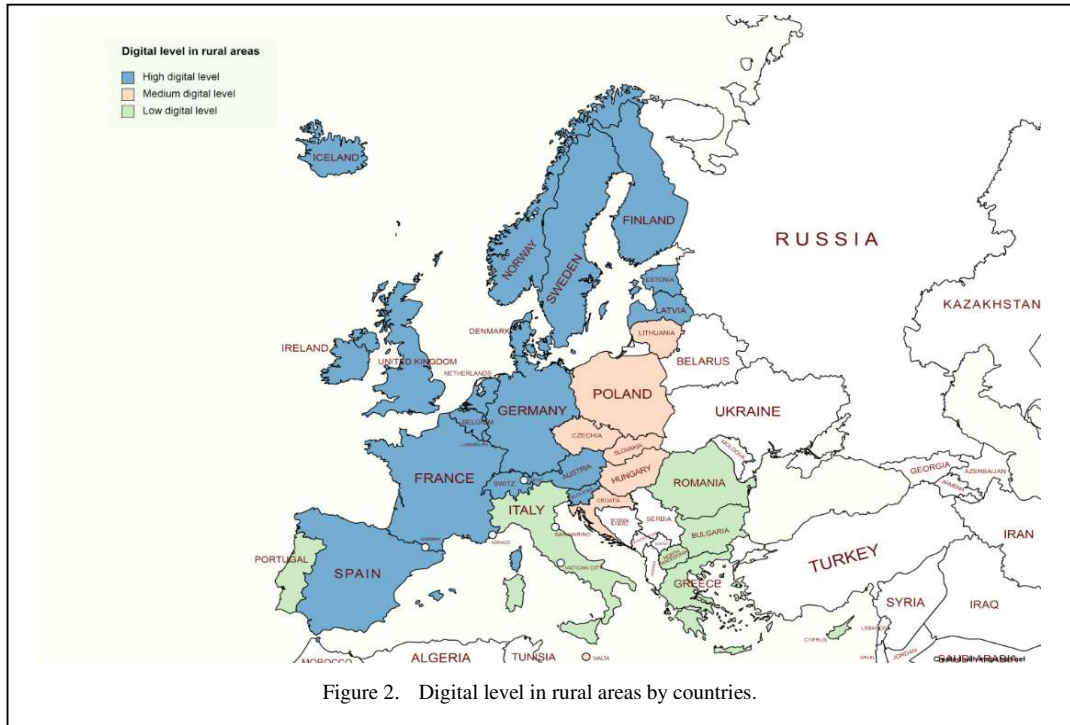

#### IV. DISCUSSION

In this research, the model which ranks 32 European countries according to digital-level indicators is developed. For collecting the data on digital-level indicators measured at the level of settlement type, the EUROSTAT database was used.

After completing the ranking, a Pareto analysis was applied to further analyze the digital level in rural areas in Europe. The countries are grouped according to the level of influence of the AS result, where the group of countries with a high digital level in rural areas includes those countries that have up to 80% influence, the group of countries with a medium digital level in rural areas includes countries with 15% influence. Finally, the remaining countries characterized by a low digital level are classified in the third group. The results obtained by Pareto analysis are presented in Fig.2.

#### V. CONCLUSION

Digitization provides new opportunities for fulfilling economic and social goals because of its broad influence. People who have access to the Internet have access to various content that supports learning and knowledge transfer.

Tiwasing and associates single out key areas of digital technologies' impact, such as economic development, information flow, knowledge transfer, electronic services, education and health services [22].

Rural areas need the same opportunities and access to information as urban areas. Nevertheless, the digital divide between urban and rural areas evidently exists and tends to deepen. In the competitive global environment, communities, companies and individuals living and operating in rural areas must embrace modern information and communication technologies in order to be competitive with their urban counterparts.

The Eurostat database enables the monitoring of digital level and digital differences, both at the level of countries and the level of the settlement type in which people live. Therefore, the paper aimed to analyze levels of digital development in rural areas and estimate the digital divide in European countries, based on which classification of European countries was made. From the point of view of the digital level in rural areas, the existence of regional digital divisions, in addition to the digital divide between urban and rural areas, is analyzed. The results indicate

significant regional differences, where the countries of Northern and Western Europe are grouped as those with a high digital level in rural areas, while the countries of Southern and Eastern Europe are with a medium and low level of digital development.

Releasing the potential of the rural population in the direction of accepting and using digital technologies plays an important role in the future of rural communities as well as the economy of regions and countries. This research's theoretical and practical implications indicate the necessity to develop specific programs by policymakers in order to the rural population accept and utilize digitization in areas with a lower digital development rate.

#### ACKNOWLEDGMENT

The research presented in this paper was done with the support of the Ministry of Education, Science and Technological Development of the Republic of Serbia, within the funding of the scientific research work at the University of Belgrade, Technical Faculty in Bor, according to the contract with registration number 451-03-68/2022-14/200131.

#### REFERENCES

- [1] Sharma, R.S., Samuel, E.M., & Ng, E.W.J. (2009), Beyond the digital divide: policy analysis for knowledge societies. *Journal of Knowledge Management*, 13(5), 373-386.
- [2] Kyriakidou, V., Michalakelis, C., & Sphicopoulos, T. (2011). Digital divide gap convergence in Europe. *Technology in Society*, 33(3-4), 265-270.
- [3] Hsieh, M. Y. (2014). The Application of the SCT and the ANP Model to Refine the Most Critical ICT Determinants in Minimizing the Digital Divide.. *Mathematical Problems in Engineering*.
- [4] Lněnička, M., & Máchová, R. (2022). A theoretical framework to evaluate ICT disparities and digital divides: Challenges and implications for e-government development. *Review of Economic Perspectives*, 22(1), 25-51.
- [5] European Commission, (2021). Communication from the commission to the European parliament, the council, the European economic and social Committee and the Committee of the regions. A long-term Vision for the EU's Rural Areas - Towards stronger, connected, resilient and prosperous rural areas by 2040 {SWD(2021) 166 final} - {SWD(2021) 167 final}. Retrieved from <https://eur-lex.europa.eu/legalcontent/EN/TXT/?uri=CELEX%3A52021DC0345>.
- [6] Doong, S. H., & Ho, S. C. (2012). The impact of ICT development on the global digital divide. *Electronic Commerce Research and Applications*, 11(5), 518-533.
- [7] Prieger, J. E. (2013). The broadband digital divide and the economic benefits of mobile broadband for rural areas. *Telecommunications Policy*, 37(6-7), 483-502.
- [8] Quaglione, D., Matteucci, N., Furia, D., Marra, A., & Pozzi, C. (2020). Are mobile and fixed broadband substitutes or complements? New empirical evidence from Italy and implications for the digital divide policies. *Socio-Economic Planning Sciences*, 71, 100823.
- [9] Fong, M. W. (2009). Digital divide between urban and rural regions in China. *The Electronic Journal of Information Systems in Developing Countries*, 36(1), 1-12.
- [10] Várallyai, L., Herdon, M., & Botos, S. (2015). Statistical analyses of digital divide factors. *Procedia Economics and Finance*, 19, 364-372.
- [11] Narayan, G., & Nerurkar, A.N. (2006). Value-proposition of e-governance services: Bridging rural-urban digital divide in developing countries.. *International Journal of Education and Development using Information and Communication Technology*, 2 (3), 33-44.
- [12] Yartey, C. A. (2008). Well-Developed Financial Intermediary Sector Promotes Stock Market Development. Evidence from Africa. *Journal of Emerging Markets Finance*, 6, 269-289.
- [13] Çilan, Ç. A., Bolat, B. A., & Coşkun, E. (2009). Analyzing digital divide within and between member and candidate countries of European Union. *Government Information Quarterly*, 26(1), 98-105.
- [14] OECD-Organization for Economic Cooperation and Development, 2008. Handbook on Constructing Composite Indicators: Methodology and User Guide Joint Research Center (JRC) 32 of the European Commission. OECD, Paris. Retrieved from <https://www.oecd.org/std/42495745.pdf>.
- [15] United Nations, (2014). E-Government Survey 2014. United Nations E-Government Survey 2014. New York: United Nations.
- [16] Radović, V., Pešić, B., Filipović, J., & Čosić, M. (2021). Agricultural advisors' role in the use of ICTS as a tool for a more sustainable Serbian agriculture. *Economics of Agriculture*, 68(2), 477-490.
- [17] Schleife, K. (2010). What really matters: Regional versus individual determinants of the digital divide in Germany. *Research Policy*, 39 (1), 173-185
- [18] Simões, F., Unay Gailhard, İ., Mujčinović, A., & Fernandes, B. (2021). How to Foster Rural Sustainability through Farming Workforce Rejuvenation? Looking into Involuntary Newcomers' Spatial (Im)mobilities. *Sustainability*, 3(13), 8517.
- [19] Velaga, N. R., Beecroft, M., Nelson, J. D., Corsar, D., & Edwards, P. (2012). Transport poverty meets the digital divide: accessibility and connectivity in rural communities. *Journal of Transport Geography*, 21, 102-112.
- [20] Townsend, L., Wallace, C., Smart, A., & Norman, T. (2016). Building virtual bridges: how rural micro-enterprises develop social capital in online and face-to-face settings. *Sociologia Ruralis*, 56(1), 29-47.
- [21] Morris, J., Morris, W., & Bowen, R. (2022). Implications of the digital divide on rural SME resilience. *Journal of Rural Studies*, 89, 369-377.



- [22] Tiwasing, P., Clark, B., & Gkartzios, M. (2022). How can rural businesses thrive in the digital economy? A UK perspective. *Heliyon*, 8(10), 10745.
- [23] Narayan, G., & Nerurkar, A.N. (2006). Value-proposition of e-governance services: Bridging rural-urban digital divide in developing countries. *International Journal of Education and Development using Information and Communication Technology*, 2(3), 33-44.
- [24] Gerli, P., & Whalley, J. (2021). Fibre to the countryside: A comparison of public and community initiatives tackling the rural digital divide in the UK. *Telecommunications Policy*, 45(10), 102222.
- [25] Philip, L., Cottrill, J., Farrington, J., Williams, F., & Ashmore, F. (2017). The digital divide: Patterns, policy and scenarios for connecting the 'final few' in rural communities across Great Britain. *Journal of Rural Studies*, 54, 386-398.
- [26] Briglauer, W., Dürr, N. S., Falck, O., & Hüscherlath, K. (2019). Does state aid for broadband deployment in rural areas close the digital and economic divide?. *Information Economics and Policy*, 46, 68-85.
- [27] Novo-Corti, I., Varela-Candamio, L., & García-Álvarez, M. T. (2014). Breaking the walls of social exclusion of women rural by means of ICTs: The case of 'digital divides' in Galician. *Computers in Human Behavior*, 30, 497-507.
- [28] Li, Y., & Ranieri, M. (2013). Educational and social correlates of the digital divide for rural and urban children: A study on primary school students in a provincial city of China. *Computers & Education*, 60(1), 197-209.
- [29] Niu, G., Jin, X., Wang, Q., & Zhou, Y. (2022). Broadband infrastructure and digital financial inclusion in rural China. *China Economic Review*, 76, 101853.
- [30] Sharma, S. K., Metri, B., Dwivedi, Y. K., & Rana, N. P. (2021). Challenges common service centers (CSCs) face in delivering e-government services in rural India. *Government Information Quarterly*, 38(2), 101573.
- [31] Luyt, B. (2006). Defining the digital divide: the role of e-readiness indicators. In *Aslib proceedings*. Emerald Group Publishing Limited.
- [32] Chang, S. I., Yen, D. C., Chang, I. C., & Chou, J. C. (2012). Study of the digital divide evaluation model for government agencies—a Taiwanese local government's perspective. *Information Systems Frontiers*, 14(3), 693-709.
- [33] Banihashemi, S. A., & Rejaei, Z. (2015). Analysis of the digital divide in Asia-Islamic countries: a TOPSIS approach. *Journal of Asian Scientific Research*, 5(4), 165-176.
- [34] Bahnamiri, M. V., Khademabbasi, S., & Valinataj, M. (2015). A multi-criteria decision method using fuzzy TOPSIS technique for ranking countries based on ICT development index (IDI). *International Journal of Applied Business and Economic Research*, 13(6), 3851-3869.
- [35] Keshavarz Ghorabae, M., Zavadskas, E. K., Olfat, L., & Turskis, Z. (2015). Multi-Criteria Inventory Classification Using a New Method of Evaluation Based on Distance from Average Solution (EDAS). *Informatica*, 26(3), 435-451.
- [36] Keshavarz Ghorabae, M., Amiri, M., Zavadskas, E.K., Turskis, Z., & Antucheviciene, J. (2017). Stochastic EDAS method for multi-criteria decision-making with normally distributed data. *Journal of Intelligent & Fuzzy Systems*, 33(3), 1627-1638.
- [37] Batool, B., Abosuliman, S. S., Abdullah, S. Ashraf, S. EDAS method for decision support modeling under the Pythagorean probabilistic hesitant fuzzy aggregation information. *Journal of Ambient Intelligence and Humanized Computing*, in press.
- [38] Chinram, R., Hussain, A., Mahmood, T., & Ali, M. I. (2021). EDAS Method for Multi-Criteria Group Decision Making Based on Intuitionistic Fuzzy Rough Aggregation Operators. *IEEE Access*, 9, 10199-10216.
- [39] Eurostat (2022, October 10). Eurostat. Retrieved from European Commission: [https://ec.europa.eu/eurostat/web/main/data/database?p\\_p\\_id=NavTreeportletprod\\_WAR\\_NavTreeportletprod\\_INSTANCE\\_nPqeVbPX RmWQ&p\\_p\\_lifecycle=0&p\\_p\\_state=normal&p\\_p\\_mode=view](https://ec.europa.eu/eurostat/web/main/data/database?p_p_id=NavTreeportletprod_WAR_NavTreeportletprod_INSTANCE_nPqeVbPX RmWQ&p_p_lifecycle=0&p_p_state=normal&p_p_mode=view)

# Quis custodiet ipsos custodes: Ethical Dilemmas of the KM Governed by AI

Željko Bjelajac<sup>1</sup>, Aleksandar M. Filipović<sup>2</sup>, Lazar Stošić<sup>3</sup>

<sup>1</sup>Faculty of Law for Commerce and Judiciary, Novi Sad, Serbia

<sup>2</sup>Faculty of Economics and Engineering Management, Novi Sad, Serbia

<sup>3</sup>Don State Technical University, Rostov-on-Don, Russia

<sup>1</sup>zdbjelajac@gmail.com, <sup>2</sup>sasha.filipovic@gmail.com, <sup>3</sup>lazarstosic@yahoo.com

**Abstract**—Knowledge Management (KM) has become one of the most discussed issues both in the academic community and among people directly working in the field of information technology (ICT). However, regardless of the academic level, the engineering and technological aspects of the phenomenon are mostly discussed. The essence of knowledge, its sources and dissemination, the questionable need to store all human knowledge in one place, the motives of knowledge givers and seekers, have received less attention in the literature than their importance dictates, both in terms of practical results and ethical issues. This paper aims to try to identify some of the ethical aspects of knowledge management, in order to show that much of the current discussion ignores or underestimates the well-known aspects of this topic, especially the risk of the “dark side” of KM and AI, which, if they were to develop, as before, freely and without the broadest social control, could threaten “life as we know it”, and especially its greatest value, human freedom as the first in the primary series of values of human life.

**Keywords** – knowledge management, artificial intelligence, Big Data, ethics, risks

## I. INTRODUCTION

No matter how much it seems that the phenomenon of KM is mystified and epistemologically almost enchanted, there is a man behind it. There are big corporations and big governments with their interests, which are believed to be not always aligned with the interests of man. At the center of this work could be found the question of who and how can or must distribute justice, that is, to declare himself the owner of the world's quantum of knowledge and to give it or not to give it to others according

to his choice. In earlier works on similar topics, we have already written about new technologies, especially AI technology, which residentially produce modern global superheroes, such as Moore's *Watchmen* or, simply, “keepers” of knowledge, all with the aim of unauthorized creation and implementation of a new model of institutional justice. This makes sense in the light of the thesis of this work, because the behavior of creators and apologists of feverish and at times hysterical storage of their human knowledge for the sake of later rational distribution of its postulates, implies the attitude that ordinary people are not capable of judicious moral reasoning, so that's why they need guardians with superhero powers: to protect people from themselves. Everything as in the Jesuit exclamation: *Omnia ad maiorem Dei gloriam*, with the fact that here, instead of the good Lord, profit corporations, new weapons and the military power of the Governments appear as beneficiaries of the glory.

*Quis custodiet ipsos custodes* is a Latin interrogative phrase written by Juvenal in his Satire. A phrase can have several similar meanings, so it is translated according to the desired meanings. In literature and dictionaries, it is most often translated as the question: “Who will guard (supervise) the guards themselves?” This is because of the notorious attitude that no one should be outside and above control and supervision, especially not those who, by law or some other rule, have power over other people. This saying can also be interpreted as an expression of ancient democracy's concern for the possible arbitrariness of people exercising power. The practice of public life shows that this

concern throughout the history of the state and government was always justified and necessary, but never sufficient to prevent or limit the abusive arbitrariness of any government. Practice has also shown that the “guards” always and easily build a system that allows them the status of untouchability, impunity and irreplaceability. That is why we consider it necessary to use the phrase mentioned in this paper as a question: *Who will protect us from the guards themselves?*

Considering that we will be proverbially methodical, logical and suspicious in our work, we believe that we cannot, beyond any reasonable doubt, assume that, regardless of all the benefits of knowledge and the way in which knowledge is interpreted, conceptualized or experienced, KM processes managed by AI always have a desirable outcome, and be useful, if not for all of humanity, at least for a significant number of the planet's inhabitants. We will start from the fact that seems indisputable to us, that there are shades of desirable and undesirable KM experiences, processes that require scientific doubt and critical discussion [1]. In this paper, we will try to point out some ethical risks of knowledge management, which, packaged in ICT, has been given the name Big Data, and which, due to its own cerebral limits, cannot be managed by humans, so they entrusted that work to machines, that is, to the phenomenon we call software artificial intelligence (AI). But software AI is just a series of ones and zeros that were written out in the necessary order and made operational by humans. By controlling AI, these same people will control Big Data and, perhaps, why not, at the behest of states and corporations, ultimately determine who, when and how, and above all, with what intention, will have access to the world's quantum of knowledge. These people will necessarily become “guardians” not only of knowledge, but also of all the consequences of privileged possession and “knowledge” of knowledge. Because of the power they could have, these “guardians” could become Nietzsche's supermen (Ger. *Übermensch*) [2], where Nietzsche's concept of the superman is not about some superior race of people. A superman is just someone who is no longer dependent on external and imposed influences and goals of society. This is someone who is ready to set clear, honest and realistic goals for his own world. The superman therefore sees happiness in the pursuit of higher goals of

being [3], goals that he determines himself, necessarily alienating himself from the common man, their benefits, and any empathy that the superman is not interested in.

Will the powers (possibilities) that the “guardians” can have been divine or diabolical? Will that world of controlled sharing of knowledge be a world with ethics or will St. Augustine's *privatio ethicae* prevail. If there are ethics, surprisingly, will the “keepers” prefer Kant's deontological ethics of duty and categorical imperative, or will they prefer the utilitarian teleological ethics of benefits of Bentham and Mill. The impact of the world of privileged shared knowledge on the freedom of man will also be important, who, even without Big Data managed by AI, has already delegated most of his freedom to the collective [4].

## II. FROM INFORMATION AGE TO AGE OF KNOWLEDGE

In the times of digitalization, globalization and the fourth industrial revolution, the total knowledge registered by humanity increases dramatically every day, and the amount of information and data generated in every area of life becomes unimaginably huge. We got the term Big Data. The term refers to collected data sets that are so large and complex that they must be processed by artificial intelligence.

Extracting actionable knowledge from the vast amount of digital information available is the next step in the ongoing evolution from the “Information Age” to the “Knowledge Age” [5]. On the other hand, the big data paradigm is an understudied technological innovation for now. The diffusion of technological innovations is never instantaneous and uniform, but inevitably creates divisions during the process of diffusion through social networks [6]. As with all previous examples of technology-based innovations for development, the big data paradigm is undergoing a slow and uneven diffusion process that is hampered by a lack of infrastructure, human capital, availability of economic resources, and, often, institutional frameworks [5].

The size and number of available data sets has grown exponentially since data is collected by devices such as resident sensing mobile devices, antennas (remote sensing), software logs, cameras, microphones, radio frequency identification (RFID) readers, and wireless sensor networks [7]. Since the beginning of the

eighties, the world's technological capacity for information storage per capita has doubled every 40 months [8]; as of 2012, 2.5 exabytes (2.5×260 bytes) of data are generated every day [9]. Based on the IDC report, the global volume of data between 2013 and 2020 grew exponentially from 4.4 zettabytes to 44 zettabytes [10]. IDC predicts that by 2025 there will be 163 zettabytes of data. According to IDC, global spending on big data and business analytics (BDA) solutions is estimated to reach \$215.7 billion by the end of 2022 [11], while Statista predicts that the global big data market will grow to 103 billion of dollars by 2027 [12]. McKinsey & Company reported in 2011 that if US healthcare used big data creatively and effectively to increase efficiency and quality, the sector could create more than \$300 billion in value each year. In the developed economies of Europe, government administrators could save more than 100 billion euros just by improving operational efficiency by using big data, and users of services enabled by personal location data could realize 600 billion dollars in consumer surplus [12].

Nowadays, large amounts of structured and unstructured data are collected. Google processes  $24 \times 10^{15}$  bytes (petabytes) of information per day. Facebook collects 3 billion likes and comments every day and downloads around 10 million images every hour, while on YouTube, every second, 800 million users store videos lasting over an hour.

Big data has led to a fundamental change in its definition, it has changed people's consciousness, created additional dimensions of understanding, and led to changes in the organization of society. The definition of big data was conditioned by at least three major changes in a different understanding of data. The first change refers to the great variety and amount of data, the second to the renunciation of accuracy in exchange for the bigger picture, and the third to the need to replace causation with correlation.

### III. DUAL ETHICS OF SYSTEMS

The ethics of KM can generally be viewed in two ways, as the “internal ethics” of the inner system in which there is a struggle between the deontological and teleological understanding of good and evil and benefit and risk, where both sides insist on, in principle, coherent arguments in their favor. According to some researchers [13], KM traditionally implies, in flagrante, a positive view of working with knowledge,

believing that corporations and governments extract, accumulate, distribute, and, correctly, with the best intention and for positive purposes, they use basic knowledge to improve the decision-making process, increase their efficiency and competitiveness, increase innovation, protect intellectual property [13].

But there is another, dark side of KM [14], where knowledge and information are withheld, dosed, emphasized, or distorted, where they are controlled, manipulated, or artificial obstacles are created for the dissemination of knowledge based on the rational interests, or emotional state of certain stakeholders. In the management of KM, meaning Big Data, there is always a conflict between two parties, a contradiction between the common good and private, not infrequently, evil interest, freedom of information, and protection of privacy and intellectual property of individuals and organizations [15].

However, our topic is broader than the inner space of Big Data and includes ethical dilemmas that go beyond the framework of the system and that correlate dramatically with the roots of life as we know it. In an earlier paper [16], we noted that the World Economic Forum (WEF) formulated and published its view at the end of 2016 on the basic fields of social life in which serious disruptions could occur if, before or during the announced implementation of KM technological solutions and AI does not solve looming ethical questions [17]. WEF experts started from the thesis that new technologies change everyday life and raise ethical questions that never existed before. “The changes in the life of humanity that artificial intelligence can and already brings are difficult to compare with what appeared before. Optimizing logistics, detecting fraud, conducting research, and implementing translations, smart computer systems are changing our lives for the better. In many cases, this is a new frontier for ethics and risk assessment as much as for new technologies” [17]. Facial recognition, hidden systems such as voice assistants, and systems for assessing the reliability of the client's financial ability, in addition to advantages, also carry serious risks. Digital technologies increasingly lead to the “democratization of our vulnerability, that is, to its increase” [18].

The introduction of the latest technology into almost all areas of modern society has led the Vatican to define ethical standards for the use of

artificial intelligence (AI) in the interest of the common good and social justice. Without questioning the benefits brought by scientific and technological progress in aviation, the space industry, medicine, natural sciences, communications, etc., church bishops and the Catholic media constantly repeat that the future of humanity depends on the creators of new technology, more precisely, on how correct their idea of the public good, the nature of human experience and social justice will be [19,20]. Agreeing that the conquests of civilization are a fact without which today's life is unimaginable, Catholic researchers evaluate the prospects for the development and use of artificial intelligence in different ways. Optimists believe it can be controlled; pessimists tend to see AI as a manifestation of the "new anti-humanism". The principle of utilitarianism, embedded in artificial intelligence systems, can eventually nullify the bright individuality of a person or the pluralism of views [19,21].

#### IV. THE COUPLING OF KM AND AI AS AN EXISTENTIAL RISK

Although numerous studies indicate that the risk of unauthorized use of AI, regardless of whether it is interaction with KM or something else, is more in the nature of humans than in the nature of artificial intelligence, scientists have long warned humanity that the "robot awakening", which at the current level of development includes smart machines based on software AI, would be especially destructive, but not the impossible development of events could mean, if not the disappearance of the world, but its transformation into a world immanent to man and his mental apparatus. Without diminishing the benefits that new technologies have brought to the world, the scientific community, excluding a large group of roboticists, electronics, and others, does not hide its concern about the growing development of artificial intelligence and its penetration into the vital spheres of public and private life. Installing systems based on neural networks of deep learning and self-learning, using machines that are many times ahead of humans in analyzing data and speed of decision-making, according to scientists, humanists, and futurists, over time can not only displace the human person from many areas of employment, but it can also destroy her mental apparatus, determine or change her inclinations, habits, communication, even destiny, threaten the inviolability of

privacy and lead to the destruction of the freedom of the human being.

Even now, without the massive implementation of AI, Big Data, and KM, we have the suspicion, or the fact, that the world's life flows are ruled by a very small number of people and that they rule in accordance with their interests [22]. That number of people could decrease in the future, which is less likely, or the same number of oligarchs could increase their power and the way to influence the daily life of people, societies, and countries. It is hard to believe that this will lead to a better and easier life for billions of people on Earth. Those billions of people will hardly benefit from KM, AI, and technologies based on it, although it is not disputed that it will be useful for someone. Scientists claim that the concentration of metadata, power, and wealth in the hands of a few people can make the entire system fatally non-transparent and "opaque", which will certainly lead to an increase in social contradictions and lead to the deterioration and drastic violation of the democratic rights and freedoms of citizens and peoples.

Scientific papers only sporadically talk about a kind of attack of AI-based technologies on the ontological being of man, an attack that could, if not, extinguish man as we know it, and that could dampen his natural impulses. A super-intelligent machine could dramatically change the nature of human existence. Russell wrote that "people who live outside a certain limit of the natural will most likely be filled with envy, malice, selfishness, anger. They can become angry and cruel, or, on the other hand, they can completely lose the joy of life, so much so that they no longer have the strength for any effort" [23]. At the same time, we are not talking about one or a hundred or a thousand people. We are talking about possible billions of people displaced from the multi-millennium cradle of their being. Eighty years ago, Fromm prophetically wrote: "He (man) has freed himself from external bonds that prevent him from acting and thinking as he sees fit. He would be free to act according to his own will if he knew what he wanted, thought, and felt. But he doesn't know that. He conforms to anonymous authorities and adopts a personal self that is not his own. And the more he does it, the more powerless he feels, and the more he is forced to consider himself. Despite external optimism and initiative, modern man is overwhelmed by a deep sense of powerlessness, which makes him

watch impending disasters unblinkingly as if paralyzed” [4].

Recognizing that at the current stage of its history, humanity does not want to think about itself outside of KM and AI technology, scientists, especially philosophers, sociologists, and theologians, are still not ready to entrust the development of the ethics of artificial intelligence to engineers and technicians. Distrust in new technologies, above all in cognitive AI technology, is explained by the prevailing social idea of the neutrality of science, and the demarcation of the competencies of the scientific and legal spheres. We think that the world is facing an academic conflict between the protagonists of power and the protagonists of the security of the Planet and “life as we know it”. It will not be the first conflict of its kind, but it will be resolved as all such conflicts have been - with an easy victory for the power apologists. As usual, this initially innocuous power will quickly and easily turn into financial and military power. This does not mean that the world has come to an end, but it does mean that it is necessary to consider how technology is used or misused.

The technology of collecting, storing, processing and distributing knowledge has already reached a stage where it cannot exist without a machine that is many times smarter and faster than a human and at the same time has no ethical scruples, nor a selection of goals acceptable to humanity. Scientific papers even state the high level of “criminal potential” of AI [24], claiming that it is a multi-faceted “dangerous machine” and that it will become more dangerous every day. History has taught us that behind every dangerous machine or dangerous invention is an equally dangerous man who naively believes that he can control it [25]. Here we quote Musk: “*With artificial intelligence, we are summoning the demon. In all those stories where there’s the guy with the pentagram and the holy water, it’s like yeah, he’s sure he can control the demon. Didn’t work out*” [26].

#### V. IGNORING ETHICS OF KM AS AN EXISTENTIAL RISK

The combination of Big Data and AI could give rise to a hitherto little-known civilizational risk. Security experts claim that the nuclear arms race can be expected to be replaced by a global autonomous arms race. Russian President Vladimir Putin announced: “Artificial

intelligence is the future, not only for Russia, but for all of humanity. It comes with enormous opportunities but also threats that are difficult to predict. Whoever becomes the leader in this sphere will become the ruler of the world” [27]. The AI machine does not understand human ethics, nor does it understand the human need for ethics, because ethics only makes it more difficult to achieve the goal set before the machine. Let's remember how little John Connor taught the Terminator that, fulfilling his goal, he must not kill people unnecessarily. Part of what people appreciate about AI machines is their efficiency and effectiveness. But if we are not clear about the goals we set for AI machines, it could be dangerous if the machine has not adopted the same goals and ethics that humans have. Commanding an autonomous car to “Take me to the airport as soon as possible” can have dire consequences. Without specifying that traffic safety rules must be followed because we value human life and property, the machine could quite effectively achieve its goal of getting you to the airport as quickly as possible and doing literally what you asked but leaving behind a bunch of accidents [27].

We explain this ethical aporia with a different understanding of the essence of the ethics of artificial intelligence, which could also be non-ethics. Engineers of all professions as well as scientists of a naturalistic provenance are engaged in translating existing and even outdated ethical concepts into machine language, not realizing that at the current level of software AI, any internal ethics of the machine is useless. The machine does not understand ethics, has no emotions and does not distinguish between good and evil. Philosophers, sociologists, humanists, and theologians - deal with the ethics of the relationship between humans and intelligent machines, and, especially, when the time comes, the very ethics of the use of artificial intelligence, which would have to evolve by accepting into its ontological and even metaphysical corpus the flagrant novum, humans a hitherto unknown artificial entity with its understanding of good and evil. It will be a new ethic, an ethic of biomimetic sensibility that people could “on the fly” adapt to new entities, creating that new ethic - why not - together with them. Of course, the future of “life as we know it” does not have to be this pessimistic and dystopian. But that means that today we need to

do something, and we need to prevent or at least postpone something.

The general question that many try not only to ask, but also to deliver to a competent place is: how wise is it to persist in constructing a machine that is many times smarter and more capable than humans? At the same time, we are not talking about the present time, but about the time that is decades ahead of us, the time when the machines that we admire today and raise to the pedestal of deities will be many times better, faster and smarter. A being with human intelligence (man) only governs himself limited by system limits, other people, morality and law. An AI machine should be managed and controlled by a human. But which man? A human controlling an AI entity would have all the power of the entity itself. Anything that an AI entity can do, its controller could do as well. Let's imagine what a challenge it would be and how we would prevent the controller from becoming "The Pied Piper of Hamelin"?

How can humans control a complex smart system? Here we are not asking how one person can do it, but how a human community organized into a sustainable society can do it. The reason humans are at the top of the food chain is not because they have sharp teeth or strong muscles. Humanity's dominance of the planet is almost entirely built on human intelligence and ethics. We can defend ourselves from larger, faster and stronger animals or derive benefits because we can create tools to control them. This raises a serious question about artificial intelligence: could one day AI have the same advantage over us? We can't just rely on pulling the plug out of the socket, because a sufficiently advanced machine will be able to anticipate this step and protect itself. Does anyone give enough thought to the moment when human beings cease to be the smartest on Earth?

How can we protect ourselves from unwanted consequences? What if artificial intelligence itself turns against humans by interpreting in its own way what is best for humans? Let's recall the plot of the movie *The Emerald Forest*. This does not mean that AI will become "evil" in the way that humans perceive evil, or in the way that Hollywood movies portray it. On the contrary, we can think of an advanced artificial intelligence system as a genie in a bottle that fulfills our wishes, but with possible dire, unintended consequences. In the

case of the machine, it will not be anger, but a lack of understanding of the whole context in which the desire is expressed.

There is no reason to believe that the goals of AI-driven KM are *a priori* biblically just and beneficial. If for no other reason than the fact that people, even experts who deal with the very essence of the phenomenon, do not know enough about all aspects of what they are working on. The scientific community needs evidence that under no circumstances will the machine turn against man, nor in any way threaten the essence of his being. Engineers believe that fear is unjustified, but one should not rush to conclusions.

## VI. CONCLUSIONS

KM is emerging as a relatively new field of study. Most of the works that try to describe KM, especially the interaction of KM and AI, offer an engineering, thus technical and technological point of view. That is good, but it is not enough, and that is why it is very important not only to describe but also to review the ethical aspects of using KM systems and processes. Most of the published texts on KM systems and practices are still based on the unquestioned belief that such systems and practices are naturally benign and that they are necessarily designed, implemented and used to improve the condition of humanity and human well-being. However, this is only one side of the phenomenon. On the other hand, we have justified doubts that reveal that many other aspects of AI-driven KM have bad goals or, at the very least, are selfish and do not result in the desired or planned improvements. *Stanford University* believes that "AI systems are proving increasingly useful in real-world applications. But they have expanded their reach, causing the risk of abuse, overuse, and explicit abuse to spread. As the capabilities of AI systems increase and are more fully integrated into societal infrastructure, the implications of losing significant control over them become increasingly worrisome. New research efforts aim to reconceptualize the fundamentals of the field so that artificial intelligence systems are less susceptible to explicit and misspecified goals. A particularly visible danger is that AI may facilitate the creation of machines that can spy and even kill on a large scale. But now there are many other more important and subtle dangers" [28]. However, it seems that the scientific community is late in competently

explaining the crucial ethical and existential risks of using AI, in general, and especially for controlling Big Data. One gets the impression that the unexpected “intelligence explosion” [29] surprised and caught the scientific community unprepared, which is struggling very hard with deeply embedded, fundamentally wrong ethical stereotypes about the relationship between good and evil in the world of AI.

That technological development is *a priori* good is the first ethical characteristic associated with AI technology. The idea of the moral neutrality of technology is deeply embedded in the common understanding of how the world works. It is not the gun that kills, but the man. The algorithm is not even alive and especially not conscious, nor it has free will; so how then can it be morally responsible? This, of course, does not mean that it is impartial, which, again, does not accuse the algorithms but their creators. Sheila Jasanoff, a professor at Harvard, in the book “The Ethics of Invention”, points out that optimism is unquestionably associated with technologies *a priori*. Everything that happens negatively with technology falls under unintended consequences [30]. It is almost never suspected that anyone had bad intentions with the technology. However, algorithms can very well be developed with bad intentions, for example, due to data theft or hacker intrusions into systems. The second feature is even more interesting, namely the various forms of responsibility shifting when using AI technology. Most often, the responsibility is shifted to the profession and to the technology itself. The use of technology requires a clear definition of who assumes responsibility and risk. Although the danger is most often noticed by experts, they only assess the degree of risk and report on it but do not make decisions. Decisions are made by others, who refer to experts [31]. In this way, responsibility is avoided, and the action of the ethics of algorithmization is minimized.

Key principles of algorithmization ethics and new regulations in the field of AI must be constantly improved to promote transparency and respect for ethical principles, especially for advanced technologies that have a greater risk of impacting human rights, such as facial recognition. To achieve these goals, we must start from the very beginning of the development of each algorithm with an “algorithmic-ethical” vision, that is, a design approach to ethics. Designing and planning an artificial intelligence

system that we can trust involves seeking consensus among political decision-makers, agencies of the OUN and other intergovernmental organizations, researchers, academia, and representatives of non-governmental organizations regarding the ethical principles that should be embedded in these technologies. For this reason, the scientific community expresses its desire to work together, in this context, at the national and international level, to promote the “algorithm of ethics”, meaning the ethical use of artificial intelligence, defined by the principles of transparency, inclusion, responsibility, impartiality, reliability, and respect for user privacy [32].

Since machines can collect, track, and analyze so much about people, it's very possible for those machines to use that information against a human. Any powerful technology can be abused. Today, artificial intelligence is being used for many good purposes, including helping us make better medical diagnoses, finding new ways to cure serious diseases, and making our cars safer. Unfortunately, as the capabilities of artificial intelligence expand, we will also see them being used for dangerous or malicious purposes. As AI technology advances rapidly, it is vital that we begin to discuss the best ways to develop AI-governed KM while minimizing its destructive potential.

#### REFERENCES

- [1] Evans, N., & McKinley, M. (2011). Ethical paradoxes in knowledge management. *Vie & Sciences De L'entreprise*, N° 188(2), 57–71.
- [2] Nietzsche, F. (1917). *Der Wille zur Macht Eine, Auslegung alles Geschehens*. Alfred Kröner Verlag.
- [3] Ars Magine. (n.d.) Fridrih Niče – Stradanje natčovekovo. Available at [https://arsmagine.com/obja\\_vljivani-tekstovi/nice/](https://arsmagine.com/obja_vljivani-tekstovi/nice/).
- [4] From, E. (1984). *Bekstvo od slobode*. Nolit.
- [5] Hilbert, M. (2013). Big Data for Development: From Information - to Knowledge Societies. *SSRN Electronic Journal*.
- [6] Rogers, E. M. (2003). *Diffusion of Innovations, 5th Edition* (5th ed.). Free Press.
- [7] Segaran, T., & Hammerbacher, J. (2009). *Beautiful Data: The Stories Behind Elegant Data Solutions* (1st ed.), O'Reilly Media.
- [8] Hilbert, M., & López, P. (2011b). The World's Technological Capacity to Store, Communicate, and Compute Information. *Science*, 332(6025), 60–65.
- [9] IBM. (2013). *Big Data Analytics*. Available at <https://www.ibm.com/analytics/big-data-analytics>.
- [10] IDC. (n.d.) *Global Spending on Big Data and Analytics Solutions Will Reach \$215.7 Billion in 2021, According to a New IDC Spending Guide*. Available at



- <https://www.idc.com/getdoc.jsp?containerId=prUS48165721>.
- [11] Statista. (2022). *Big data and business analytics revenue worldwide 2015-2022*. Available at <https://www.statista.com/statistics/551501/worldwide-big-data-business-analytics-revenue/>.
- [12] Statista. (2022b, July 27). *Forecast revenue big data market worldwide 2011-2027*. <https://www.statista.com/statistics/254266/global-big-data-market-forecast>
- [13] Alter, S. (2006). Goals and Tactics on the Dark Side of Knowledge Management. *Proceedings of the 39th Annual Hawaii International Conference on System Sciences (HICSS'06)*.
- [14] Land, F., Nolas, S.M., Amjad, U. (2004). Knowledge Management: The Darker Side of Knowledge management. *Ethicomp Journal*, 3(1).
- [15] Land, F., Amjad, U. and Nolas, S-M. (2007), "The Ethics of Knowledge Management", *International Journal of Knowledge Management*, 3(1): 1-9.
- [16] Bjelajac, Ž. & Filipović, A. (2021). Artificial Intelligence: Human Ethics in Non-Human Entities. *Proceedings of the 3<sup>rd</sup> Virtual International Conference "Path to Knowledge Society – Managing Risks and Innovation*, (pp. 183-190).
- [17] Bossman, J. (2016). Top 10 ethical issues in artificial intelligence. *World Economic Forum*. Available at <https://www.weforum.org/agenda/2016/10/top-10-ethical-issues-in-artificial-intelligence>.
- [18] Pierri, M. (2019). *Intelligenza artificiale, che cosa lega filosofia e ingegneria secondo Luciano Floridi (Oxford)*. Formiche.net. Available at <https://formiche.net/2019/03/intelligenza-artificiale-filosofia-ingegneri-a-etica-floridi-oxford/>.
- [19] Yazkova, V. (2020). „Servant“ or „Master?“. Catholic Ethics and Artificial Intelligence. *Scientific and Analytical Herald of IE RAS*, 17(5), 113–120.
- [20] Spadaro, A. (2020). *Intelligenza artificiale e giustizia sociale*. La Civiltà Cattolica. Available at <https://www.laciviltacattolica.it/articolo/intelligenza-artificiale-e-giustizia-sociale/>.
- [21] Paliaga S. (2019). *Liberarsi dalla dittatura futuribile degli algoritmi*. Avvenire. Available at <http://www.meltemieditore.it/wp-content/uploads/paliaga-avvenire-societa-automatica-stiegler.pdf>.
- [22] Siebert, T. (n.d.). *MediaDailyNews: String Theories: How Many People Run The World?* Available at <https://www.mediapost.com/publications/article/316538/string-theories-how-many-people-run-the-world.html>.
- [23] Russell, B. (1949). *Authority and the Individual*. George Allen and Unwin.
- [24] Caldwell, M., Andrews, J. T. A., Tanay, T., & Griffin, L. D. (2020). AI-enabled future crime. *Crime Science*, 9(1). <https://doi.org/10.1186/s40163-020-00123-8>.
- [25] Harfield, J. (2021). *Is AI Dangerous? 5 Immediate Risks Of Artificial Intelligence*. Available at <https://www.makeuseof.com/is-ai-dangerous-5-immediate-risks-of-artificial-intelligence/>.
- [26] Yu, G. (2017). *Machine Learning Is The Most Dangerous Trend In Tech (Though Not For The Reasons You Think)*. Available at <https://becominghuman.ai/machine-learning-is-the-most-dangerous-trend-in-tech-though-not-for-the-reasons-you-think-162440abb29b>
- [27] Marr, B. (2021). *Is Artificial Intelligence Dangerous? 6 AI Risks Everyone Should Know About*. Bernard Marr. Available at <https://bernardmarr.com/is-artificial-intelligence-dangerous-6-ai-risks-everyone-should-know-about/>.
- [28] Littman, M. L., Ajunwa, I., Berger, G., Boutilier, C., Currie, M., Doshi-Velez, F., Hadfield, G., Horowitz, M. C., Isbell, C., Kitano, H., Levy, K., Lyons, T., Mitchell, M., Shah, J., Sloman, S., Vallor, S., & Walsh, T. (2021). *Gathering Strength, Gathering Storms: The One Hundred Year Study on Artificial Intelligence (AI100) 2021 Study Panel Report*. Stanford University. Available at <http://ai100.stanford.edu/2021-report>.
- [29] Graves, M. (2022, May 16). *Why We Should Be Concerned About Artificial Superintelligence*. Sceptic. Available at [https://www.sceptic.com/reading\\_room/why-we-should-be-concerned-about-artificial-superintelligence/](https://www.sceptic.com/reading_room/why-we-should-be-concerned-about-artificial-superintelligence/).
- [30] Jasanoff, S. (2016). *The Ethics of Invention: Technology and the Human Future*. W.W.Norton.
- [31] Ivanković, Ž. (2017). *Etika i tehnologija: Hoće li algoritmi biti pravedniji od sudaca*. MR EŽA. Available at <https://mreza.bug.hr/etika-i-tehnologija-hoce-li-algoritmi-biti-pravedniji-od-sudaca/>.
- [32] Renaissance Foundation. (2020). *Rome Call for AI Ethics*. Available at <https://www.romecall.org>.

# Industrial Property Rights as Types of Capital in Commercial Companies in Turkish Law

Mustafa Yasan<sup>1</sup>

<sup>1</sup>Izmir Democracy University Faculty of Law, İzmir, Türkiye

<sup>1</sup>avmyasan@yahoo.com

**Abstract**—Industrial property rights are regarded as a sub-type of intellectual property rights and regulated in the Industrial Property Code, which is a unique and specific codification. Industrial property rights are among the assets that can be brought to commercial companies as capital in kind. However, there is a prerequisite that must be fulfilled for this possibility. That is, the industrial property right must be registered in the special registry which will be kept by Türkiye Trademark and Patent Organisation. For industrial property rights to be brought as capital in kind, the commitment related to industrial property rights must also be registered in their special registers. Otherwise, the registration request of the commercial company will be rejected by the trade registry officer. For this reason, if the industrial property right is committed as capital, a result such as not letting the company initiative be established as a sanction for not fulfilling this commitment arises.

**Keywords** - industrial property rights, commercial companies, capital commitment, Turkish company law, intellectual property rights

## I. INTRODUCTION

This study focuses on bringing industrial property rights to commercial companies as capital in terms of Turkish law. Industrial property rights can be committed to commercial companies as capital in kind. However, the condition that must be fulfilled for this commitment to be valid is that the industrial property right is registered in the special registry. Only registered industrial property rights can be brought to commercial companies as capital. In addition, other conditions have been regulated in the scattered articles of the Turkish Code of

Commerce No. 6102 (TCC) [1] regarding the ability to bring industrial property rights as capital to commercial companies and especially joint-stock companies. All these conditions and special requirements reflect the principle of capital protection. For this reason, this approach of the legislator is quite accurate. On the other hand, it is seen that all problems and question marks related to bringing industrial property rights to commercial companies as capital still need to be resolved in the 10-year implementation of new (?) TCC. In this study, these question marks will be emphasized and evaluations and solution suggestions will also be included.

## II. INDUSTRIAL PROPERTY RIGHTS AND CAPITAL QUALIFICATION IN TURKISH LAW

### A. Industrial Property Rights in Turkish Law

In a broad sense, intellectual property rights consist of copyright and industrial property rights. These two categories of rights, which constitute the scope of intellectual property law in Turkish law, are regulated independently of each other in two separate sources of legislation [1]. Accordingly, while copyright is regulated in the Code on Intellectual and Artistic Works No. 5846 [2], which entered into force in 1951, industrial property rights are regulated in the Code on Industrial Property No. 6769 (CIP) [3], which entered into force in 2017. In the CIP, general provisions regarding industrial property rights are included, and then each type of industrial property right is specifically regulated [4]. Finally, there are common provisions applicable to all industrial property rights in the Code. According to the census in the

CIP, trademark, geographical indication, design, patent and utility model are listed as industrial property rights. The scope of the legislation on industrial property rights is also included in TCC No. 6102, which entered into force in 2012, because industrial property rights are both among the natural assets of the commercial enterprise (TCC art. 11/3) and considered one of the types of capital in kind that can be brought to commercial companies (TCC art. 127/1).

#### *B. Capital Element in Commercial Companies*

Capital is one of the conceptual elements of commercial companies. In Turkish law, commercial companies are listed by name in TCC art.124/1. Accordingly, collective companies, limited partnerships (commandit companies), joint-stock companies, limited liability companies and cooperatives are listed as commercial companies. General provisions applicable to all commercial companies are included in TCC art.124-210. Articles 127 and 128, among these provisions, regulate the types of capital that can be brought to commercial companies and how the debt of capital in kind can be fulfilled in commercial companies [5].

The types of capital that can be brought to commercial companies can be identified in three categories. These are cash capital, capital in kind and labour capital. Cash capital consists of money and money receivables. Capital in kind consists of all kinds of assets that have economic value and that can be transferred legally. Labour capital comprises workforce, commercial reputation, professional experience and technical knowledge (know-how) [6].

The subject of capital investment debt in commercial companies is regulated in TCC art.127. In this article, the values, assets that can be brought to commercial companies as capital are determined in a long list. According to this,

- a) Money, receivables, negotiable instruments and shares of capital companies,
- b) Intellectual property rights,
- c) Movables and all kinds of immovables,
- d) Benefiting and usage rights of movable and immovables,
- e) Personal labour,
- f) Commercial reputation,
- g) Commercial enterprises,

- h) Legally used transferable electronic media, domains, values such as names and marks,
- i) Mining licenses and other rights with economic value,
- j) All transferable and cash value can be brought to commercial companies as capital.

At first glance, this determination can be considered a limited count (numerous-clausus). However, it must first be stated that this count in TCC art.127 is unlimited. Because, in the last paragraph of Article 127/1 of the TCC, it is regulated that all kinds of assets that can be economically evaluated and transferred can be brought to commercial companies as capital [5]. Therefore, we must accept that the census in TCC art.127/1 is made only to give examples.

In the TCC, a legal regime that differs according to the types of capital is regulated for commercial companies. Accordingly, all capital types are valid in collective companies. On the other hand, in limited partnerships, while only commandite partners can bring all types of capital to the company, commanditer partners are not able to bring labour capital to the company. Joint-stock and limited liability companies are commercial companies that are unsuitable for labour capital due to their capital company qualifications. In addition to this restriction, some extra criteria regarding the assets that can be brought as capital in kind in joint-stock and limited liability companies have also been validated [7]. Accordingly, in joint-stock and limited liability companies, an asset with a lien on it has been given an injunction and restricted by a limited right in rem, cannot be brought as capital in kind [6].

Industrial property rights can also be brought as capital in commercial companies. As a matter of fact, this acceptance is a result of the fact that intellectual property rights are listed in TCC art.127/1. In fact, even if it was not explicitly regulated that intellectual property rights could be brought as capital, we could still reach the conclusion that industrial property rights could be brought to commercial companies as the capital since industrial property rights are assets that can be transferred and evaluated in cash, just like underlined in TCC [8].

### III. FULFILMENT OF CAPITAL INVESTMENT DEBT REGARDING INDUSTRIAL PROPERTY RIGHTS

#### A. *Fulfilling the Debt to Put Capital in Kind*

There are special provisions in the special part of the TCC regarding the fulfilment of the debt to put in capital, to which each type of commercial company is subject. On the other hand, the legislator has regulated general principles and provisions in the article 128 of the TCC. Unless otherwise regulated by special provisions, the legal regime regulated in TCC art.128, which is valid, includes the principles regarding the commitment of immovables, movables and intellectual property rights and other values as capital and the fulfilment of these commitments in addition. As can be seen, the subject of TCC art.128/2 is only capital in kind [8]. Considering the nature of industrial property rights as capital in kind, TCC art.128 should be taken into consideration for the legal regime that can be brought to all commercial companies [9].

#### B. *Commitment of Industrial Property Rights as Capital*

When all intellectual property rights, including industrial property rights and other values and rights registered in their private registers, are committed to commercial companies as capital, they must be recorded in their special registers in order for this commitment to be considered valid, in other words, for the said rights and values to be accepted as capital in kind. (TCC art.128/2). While there are requirements such as annotation in the land registry in the commitment of the immovables and the requirements such as entrusting the movables to a reliable person in the commitment, it is stipulated that the industrial property rights are recorded in the relevant registers when the commitment is made [10]. If this condition is not fulfilled, the establishment of the company is not allowed to be completed by the officials.

This situation is a result of the understanding and approach of the legislator as the priority for protecting the capital. Considering that industrial property rights are required to be registered in the relevant registry in order to be accepted as capital and the rights already registered in TCC art.128/2 are considered, it is indirectly understood that it is impossible to bring an unregistered industrial

property right to a commercial company as capital [8].

In TCC art.128/2, it has been accepted as an obligation to determine the value of these commitments by expert examination for the capital commitments in kind to be valid. If industrial property rights are also committed, it is an obligation to write the value calculated by the experts in the articles of association. The expert is not required to be appointed by the court as principle.

On the other hand, if the industrial property right is committed to the joint-stock company as capital, the expert who will evaluate the industrial property right according to TCC art.343 must be an official expert appointed by the court, as a result of the application made by founder commits for industrial property right [10]. Anyone with interest may object to the valuation carried out by the official expert. The court that will examine the objection is the court that appoints the expert too, and the court's decision is final.

#### C. *Bringing Industrial Property Rights to a Commercial Company*

In capital elements registered in special registers, including industrial property rights, the moment when these elements are transferred into the ownership of the commercial company is the moment for the commercial company to gain legal personality [11]. In other words, when the registration process required for the establishment of the commercial company takes place and the commercial company gains legal personality, the industrial property rights committed to the commercial companies as capital are transferred to the newly established commercial company automatically (TCC art.128/4).

The registration required for the establishment of commercial companies is of a founding nature [11]. This founding characteristic also applies to the transfer of industrial property rights to a commercial company. On the other hand, the transfer of other rights registered in their private registers, including industrial property rights, to commercial companies should be registered in the relevant registers later. For industrial property rights, the registry kept in the Turkish Patent and Trademark Office is sufficient to fulfil this requirement [12]. However, this registration is not founding; it is informative.

#### IV. EVALUATION OF THE LEGAL REGIME REGARDING BRINGING INDUSTRIAL PROPERTY RIGHTS AS CAPITAL

TCC, which accepts all kinds of assets that can be transferred and economically evaluated as capital, has also adopted industrial property rights as an asset item that can be brought to all commercial company types [12]. For industrial property rights to be brought in as capital in kind, according to the TCC, they must be registered in the special registers kept at the Turkish Patent and Trademark Office. Although it is not explicitly stipulated in the TCC that an unregistered industrial property right cannot be brought as capital to commercial companies, this conclusion can be reached through interpretation of the regulation in TCC art.128/2. It is possible to come across opinions suggesting that industrial property rights that are not registered can also be brought as capital in kind, albeit exceptionally in Turkish doctrine, despite the relevant text of the article [12]. This situation should be corrected as it leads to uncertainty in law practice.

In the case of the undertaking industrial property rights to commercial companies as capital in kind, it is a very appropriate provision for the principle of protection of capital that a valuation must be made first and experts must make this valuation in order for this commitment to be valid. However, the legislator has created a difference between joint-stock companies and other commercial companies regarding the qualification of the expert. In joint-stock companies, the appointment of experts by the courts is an obligation, although experts can be authorised by the partners committing the debt of capital investment in other company types [13]. This difference results from the necessity of protecting the capital since joint-stock companies are capital companies and companies where savings are converted into investments [9]. However, the same requirement should be applied at least to limited liability companies.

A constraint on bringing industrial property rights to commercial companies as capital is that the industrial property right is not limited to precautionary injunctions, liens and limited real rights. At this point, a question arises. If the industrial property right has been the subject of a license agreement, if another person has been authorized to benefit and use the industrial property right with the license agreement, is it possible to undertake the industrial property right

as capital There is no clear answer to this question in the Code. In conclusion, the constraints enumerated in the TCC are limited and cannot be subject to expansionary interpretation [12]. For this reason, the fact that the industrial property right is subject to the license agreement does not prevent it from being brought to commercial companies as capital in kind. However, the ideal point is, of course, to include a clear provision in this regard in the TCC.

#### V. CONCLUSION

Industrial property rights are among the assets in kind, but only if they are registered, it is possible to bring them as capital to commercial companies. Being unregistered causes the industrial property right to be subject to unfair competition provisions. In addition, it leads to a result such as not being brought to commercial companies as capital in kind. In order to bring a registered industrial property right to commercial companies as capital in kind, it should be shown in the articles of association specifically and with its value determined by the expert. This conclusion is a requirement of the principle of protection of capital.

In joint-stock companies, the expert must be appointed by the court. On the other hand, in limited liability companies, the approach of joint-stock companies should be adopted. For industrial property rights to be brought in as capital, an interim injunction, lien, or limited real right should not be established on the industrial property right. This necessity is another essential prerequisite. These restrictions shown in the law are limited in number. For this reason, although the industrial property right is subject to the license agreement and the authority to use and benefit from the industrial property right is transferred to others as a result of this agreement, this case should not prevent the industrial property right from being brought in as capital.

#### REFERENCES

- [1] Official Gazette, Date: 14.02.2011, No: 27846.
- [2] Official Gazette, Date: 13.12.1951, No: 7981.
- [3] Official Gazette, Date: 10.01.2017, No: 29944.
- [4] Ayhan, R., Çağlar, H., Yıldız, B., & İmirlioğlu, D. (2021). *Sınai Mülkiyet Hukuku*. Adalet Yayınevi, Ankara. [Ayhan, R., Çağlar, H., Yıldız, B., & İmirlioğlu, D. (2021). *Industrial Property Law*, Adalet Publish House, Ankara]
- [5] Yasaman, H. (2012). *Fikri ve Sınai Mülkiyet Hukuku. Vedat Kitapçılık*, İstanbul. [Yasaman, H. (2012).

- Intellectual and Industrial Property Law*. Vedat Publishing, İstanbul]
- [6] Pulaşlı, H. (2022). *Şirketler Hukuku Genel Esaslar*. 8. Baskı, Adalet Yayınevi, Ankara. [Pulaşlı, H. (2022). *Fundamentals of Company Law*. 8<sup>th</sup> Edition, Adalet Publish House, Ankara]
- [7] Bilgili, F., & Demirkapı, E. (2021). *Şirketler Hukuku Dersleri*. 8. Baskı, Dora Yayınevi, Bursa. [Bilgili, F., & Demirkapı, E. (2021). *Company Law Course Book*. 8<sup>th</sup> Edition, Dora Publish House, Bursa]
- [8] Kendigelen, A., & Kırcı, İ. (2021). *Şirketler Hukuku Cilt I*, Oniki Levha Yayınevi, İstanbul. [Kendigelen, A., & Kırcı, İ. (2021). *Company Law Volume I*. Oniki Levha Publish House, İstanbul]
- [9] Çebi, H. (2021). *Şirketler Hukuku*. Seçkin Yayınevi, Ankara. [Çebi, H. (2021). *Company Law*, Seçkin Publish House, Ankara]
- [10] Şener, O. H., (2022). *Teorik ve Uygulamalı Ortaklıklar Hukuku*. 5. Baskı, Seçkin Yayınevi, Ankara. [Şener, O. H., (2022). *Company Law with Theory and Practic*. 5<sup>th</sup> Edition, Seçkin Publish House, Ankara]
- [11] Bahtiyar, M. (2022). *Ortaklıklar Hukuku*, 16. Baskı, Beta Yayınevi, İstanbul. [Bahtiyar, M. (2022). *Company Law*, 16<sup>th</sup> Edition, Beta Publish House, İstanbul]
- [12] Arbek, Ö. [2008]. *Fikir ve Sanat Eserlerine İlişkin Lisans Sözleşmesi*. Yetkin Yayınevi, Ankara. [Arbek, Ö. [2008]. *Licence Contract for Literary and Artistic Works*. Yetkin Publish House, Ankara.
- [13] Tekinalp, Ü. (2020). *Sermaye Ortaklıklarının Yeni Hukuku*. 5. Baskı, Vedat Kitapçılık, İstanbul. [Tekinalp, Ü. (2020). *New Law of Capital Companies*. 5<sup>th</sup> Edition, Vedat Publishing, İstanbul]



# Advantages and Limitations of the Implementation of Intelligent Inventory Management Systems in the Supply Chain

Nebojša Zorić<sup>1</sup>, Vijoleta Vrhovac<sup>2</sup>, Stevan Milisavljević<sup>3</sup>, Dejan Ilić<sup>4</sup>, Stana Vasić<sup>5</sup>

<sup>1,2,3,4,5</sup>Faculty of Technical Sciences, University of Novi Sad, Novi Sad, Serbia

<sup>1</sup>nebojsa.zoric12@gmail.com, <sup>2</sup>violeta.vrhovac@uns.ac.rs, <sup>3</sup>steva@uns.ac.rs,

<sup>4</sup>dejan.ilic@formula-transport.com, <sup>5</sup>vasic.stana@uns.ac.rs

**Abstract**—Information makes the supply chain visible and transparent which is necessary for making appropriate business decisions. The application of intelligent systems in inventory management is essential to ensure maximum protection and preservation of the use value of products in the process of physical distribution, storage and sale. The timely exchange of information between participants enables the principle of delivery, right product, right time, right place, right quantity, right quality, right price, and right consumer. In relation to this, the subject of the research of this paper is the analysis of the issue of introducing intelligent systems for efficient inventory management in supply chains and determining the connection between the application of intelligent systems and the profitability of the supply chain. It is also necessary to identify limitations as well as factors that positively influence the introduction and accelerated application of intelligent systems in transport, storage, physical-manipulative operations, and display of products to the place of their final purchase. The practical significance of the research is reflected in the fact that based on the results obtained, supply chain managers can identify critical points and limitations that prevent the application of intelligent systems in inventory management. Based on this, they can define and take concrete measures that impact the business result (profitability) of the entire supply.

**Keywords** - supply chain, inventory management, information technology

## I. INTRODUCTION

Supply chain management is the process of coordinating the management of production operations and the management of integrated logistics to ensure a continuous flow of products and services. This implies the entire transfer of physical goods, services, and information necessary to produce and value goods, that is, to reach the end consumer. At the same time, information is a link that unites the previous aspects.

Modern business and the increasing demands regarding competition and the needs of end users influence the further development of supply chains. Logistics and supply chains need to respond to challenges such as globalization, demographic changes, technological innovations, electronic commerce, and a lack of logistics networks and storage capacities [1].

For companies to enter this type of market game as soon as possible, both with users and competition and with external influences, threats, and opportunities, at least two critical turns in business are necessary. First, companies must create strong and unbreakable connections with consumers, in terms of their needs, desires, and expectations. The second step would have to be a continuous investment in the development of modern information technology, which ensures a fast and secure flow of information along the entire supply chain. Information



technologies influence the automation of supply chain processes using artificial intelligence, robots, unmanned vehicles, blockchain, and other technologies [2]. Finally, but equally important is a quality, motivated and trained workforce, which should implement all processes, that is, the need to create intellectual capital within the supply chain [3].

The logistics information system is a combination of information technologies and organizational-functional units within companies. An information system is a computer-supported system that supports integrated logistics activities to achieve the desired results within the supply chain. A well-designed information system should help optimize the production process, affect inventory reduction, eliminate activities that do not create added value, improve the level of service to customers, help management in the decision-making process, and ensure the coordination of activities in the organization [4].

The efficiency of the logistics system is reflected, among other things, in the fulfilment of two goals, the reduction of costs through inventory management and the smooth functioning of the physical logistics chain. These goals are mutually conflicting, so information systems should provide adequate support for making the best decisions. This support implies continuous processes of collecting, memorizing, processing, and sending information. The information must be of good quality, which means timeliness, accuracy, and effective communication. The functional subsystems in which these processes occur to make up the information system and the decision-making system. Without an information system and a decision-making system, the management of stocks and physical processes of the business logistics system would be almost impossible [5].

The electronic business aims to connect all forms of information and communication technology in business relations, starting with trade, production, and service organizations, through suppliers, consumers, and state administration. The main drivers of change are the achievement of operational efficiency, increase in transparency, demand volatility, new

markets, growth in business performance, and change in consumer habits [6].

The use of intelligent systems has facilitated inventory monitoring and has contributed to more efficient management. Together with the timely exchange of information, the application of packaging with RFID (Radio Frequency Identification) tags, GPS (Global Positioning System) tags, and other sensors enables more accurate planning of operations and better visibility of critical elements within the supply chain. In addition, the implementation of intelligent packaging in supply chains will make them more flexible for the needs of the market and sustainable in modern economic conditions, while taking into account the fight against counterfeiting as well as the protection of the human environment, the safety, and health of consumers [7]. This achieves optimal inventory management, reducing the time of transportation and delivery of products and improving the efficiency of the entire chain.

In the Western Balkans region, the application of intelligent systems and modern technology in inventory management is at the very beginning. A small number of manufacturers, transport companies, and retailers decide on this type of technology for various reasons (high initial implementation costs, lack of modern IT technology, lack of trained personnel, etc.). Given that it is a market of over 20 million inhabitants, it is necessary to investigate the limitations as well as the advantages that appear among supply chain participants, regarding the possibility of applying intelligent systems in inventory management and their impact on business results along the entire supply chain.

## II. THEORETICAL BACKGROUND

The modern business environment, the development of technology, and numerous market and economic challenges have influenced companies to review, reorganize and improve their supply chains. To remain competitive, companies achieved a higher degree of coordination with each other, which over time resulted in a very strong integration of all business entities in the supply chain.

The future of the supply chain is in the application of the IoT (Internet of Things) as a

unique intelligent system that combines large amounts of data on product quality, inventory control and condition, storage and preservation conditions, usage value, etc. [8]. In this context, supply chains with an integrated ERP system (Enterprise Resource Planning) ensure efficient and effective communication between supply chain participants and final consumers. ERP systems as standard, complex, software packages were developed to meet the business requirements of companies as a whole, and as such incorporated experience and skills are taken from companies, as well as existing users of ERP solutions. ERP systems enable efficient and effective communication and cooperation of companies both with suppliers and with clients [9]. Furthermore, RFID wireless product identification technology is redefining supply chain processes. RFID provides significant benefits such as improved speed, accuracy, efficiency, and security of information sharing, reduced storage, handling, and distribution costs, reduced inventory, and improved cash flow [10]. Of particular importance in the further development of supply chains comes from the application of artificial intelligence for inventory management in supply chains. Artificial intelligence reduces the error to a minimum and reduces the involvement of the human factor. It provides a better configuration of supply chains (location of warehouses, geographical distribution, etc.), automation of warehouses through the development and application of autonomous vehicles AGV (Automated guided vehicles), and more precise management of customer requests through the continuous use of machine learning algorithms [11]. The importance of Cloud Computing, especially for small and medium-sized enterprises as participants in the supply chain, is increasing. Cloud Computing tends to increase the flexibility and efficiency of service deliveries and ensures a better alignment of IT services with dynamic business requirements without investing in new software, infrastructure, training of new personnel, and purchase of new licensed programs [12,13]. One of the ways to effective inventory management is the introduction of a warehouse management system - WMS (Warehouse Management System). WMS is a storage and transportation system connected to an information system for inventory management [14]. WMS works on the

principle of connecting computers, the Internet, barcodes, mobile, and other technologies into one closed system that provides automatic monitoring of the entry, movement, and exit of materials, semi-finished products, and finished products in the warehouse. A well-implemented WMS should have the possibility of integration with other information technologies within the supply chain, above all the possibility of further upgrading and a good connection with the ERP system [15].

### III. METHODOLOGY

#### A. Hypotheses and Research Objective

The empirical research aims to analyze the limitations and advantages of the intelligent system's introduction in inventory management, as well as to determine the connection between the application of intelligent systems and the business result (profitability) of the supply chain. Thus, the defined research goal was operationalized through the following three research hypotheses, which read:

H1 - limitations to the implementation of intelligent inventory management systems differ statistically significantly depending on the supply chain participants. The first research hypothesis seeks to test whether constraints differ across supply chain participants. The goal of testing this research hypothesis is actually to determine whether supply chain participants face different problems when implementing intelligent systems.

H2 - the benefits of implementing intelligent inventory management systems differ statistically significantly depending on the supply chain participants. This hypothesis seeks to test the benefits of implementing intelligent systems and whether these benefits differ among different supply chain participants.

H3 - the application of intelligent inventory management systems in the supply chain is statistically significantly related to the business result (profitability) of the supply chain. This research hypothesis tests whether the intelligent system's introduction has a positive or negative implication on the profitability and business performance of the entire supply chain.

## *B. Measurement Variables*

Following the set hypotheses, the research included several independent and one dependent variable. Independent variables within the analysis are defined as characteristics of supply chain participants - size, revenue, number of employees, and activity.

As indicators of limitations, the respondents ranked: 1) high initial costs of implementing intelligent systems, 2) long period of implementation, 3) problems of standardization, certification, and permits of competent authorities, 4) insufficient training of employees, 5) lack of modern technology and 6) high final the price of the product.

As indicators of advantages, the respondents ranked: 1) more efficient synchronization of production, transport, and distribution activities, 2) reduction of inventory costs, 3) full application of the JIT delivery principle, 4) timely replenishment of inventory, 5) more efficient use of warehouse space, 6) inclusion of warehouse- manipulative operations, 7) monitoring the atmospheric conditions of storage and stock keeping and 8) reducing the rate of product returns due to expiry of the shelf life.

The business result (profitability) of the supply chain was chosen as the dependent variable. The dependent variable business result (profitability) is operationalized through three items, which measure the importance of the intelligent system's introduction on the business result (profitability) of the supply chain. These items concern: the volume of business income, inventory costs, and speed of response to consumer needs.

## *C. Sample and Research Procedure (Participants and Experiment Procedure)*

Testing the set hypotheses and presentation of the obtained results requires the application of various statistical methods. The method of descriptive statistics will be used to describe the obtained results and analyze the respondents' answers. Further, the one-way analysis of variance (ANOVA) test with Scheffe's Post hoc test and the application of the Multiple Regression Analysis methods will be the most appropriate for testing the set hypotheses.

The research was conducted on a sample of 127 managers (middle and senior level) of the supply chain in the market of the Western Balkans. In terms of sample structure, managers from the production, physical distribution, wholesale and retail sectors are equally represented. The sample is structured from business entities as participants in the supply chain that differ according to their size, profitability, and field of work.

The research was carried out electronically based on a questionnaire consisting of 15 statements for the limitations and advantages of the implementation of intelligent systems and 3 statements for the business result and profitability of the supply chain. The respondents were asked to rank their satisfaction with the offered indicators, that is, how they evaluate the impact of the given indicators on the application of intelligent systems in the economic entities in which they work. A standard Likert-type scale was used to rank the offered indicators (1 - unimportant, 5 - crucially important).

## **IV. RESULTS AND DISCUSSION**

The authors of this paper conducted more extensive empirical research on a sample of 127 managers. Data from the research were processed in the SPSS statistical program. For this paper, we single out only a few results.

To examine the first and second research hypotheses, a series of One-Way Analyses of Variance (ANOVA) was applied. As an independent grouping variable, the participants of the supply chain were selected, namely: according to the field of activity (manufacturers, transport companies, wholesalers, and retailers), which differ in terms of size (micro, small, medium, and large), realized business income (up to €100,000, €100,000-500,000, €500,000-1,000,000, over €1,000,000) and the number of employees (up to 10, 10-50, 50-250, over 250). The independent variable in each of the applied One-Way Analyses of Variance was the respondent's answer on the scale of limitations and advantages of the application of intelligent inventory management systems.

H1 - limitations to the implementation of intelligent inventory management systems differ statistically significantly depending on the supply chain participants.

Limitations are operationalized through seven items. The surveyed representatives of the supply chain participants gave the highest ranks to the existence of limitations concerning the lack of modern technology, followed by the high final price of the product (final retail price) and doubts about the absence of commercial interest from intelligent system's introduction. Respondents rank the long installation time as the least notable limitation. Respondents mostly agree with each other about the limitation regarding the long period of installation.

Based on the conducted tests, it follows that the research hypothesis H1 is accepted. Furthermore, it is concluded that the limitations of the intelligent inventory management system's application differ statistically significantly depending on the supply chain participants. The obtained results showed that these differences are large economic entities, 2) between companies that generate up to €500,000 compared to companies that generate income up to €100,000 and over €1,000,000, 3) between companies with over 250 workers to other participants in the supply chain and 4) between the production and physical distribution sectors, with differences also present in the wholesale and retail sectors.

H2 - the benefits of implementing intelligent inventory management systems differ statistically significantly depending on the supply chain participants.

The analyzed advantages during the intelligent system's introduction are described through eight items. The biggest advantage when introducing intelligent systems is seen in the more efficient synchronization of production, transport, and distribution activities and monitoring of atmospheric conditions of storage and stock keeping. Respondents assigned the lowest ranking of answers according to the offered items (indicators) to advantages that describe more efficient use of storage spaces and reduction of inventory costs. Respondents differed the most according to the answer to the advantage - speeding up storage-manipulative operations.

The obtained results show that the research hypothesis H2 is rejected, and the conclusion is that the benefits from the application of intelligent inventory management systems do

not differ statistically significantly depending on the participants in the supply chain. In other words, all supply chain participants have identical expectations regarding the benefits of implementing intelligent systems in inventory management. The expectations are identical regardless of the business sector, the number of employees, and the company size. Minor deviations are present in the volume of realized business income, where individual participants rank the expected advantages differently.

The research confirmed the initial assumptions that the barriers and limitations to the intelligent system's introduction in inventory management are different, depending on the participants in the supply chain. These limits differ depending on the size of the business entity, the number of employees, realized business income, and the business area. On the other hand, the research confirmed that, contrary to expectations, the benefits of implementing intelligent inventory management systems do not differ among different supply chain participants. All analyzed participants have identical expectations from the intelligent system's implementation, regardless of their size, number of employees, and field of business.

H3 - the application of intelligent inventory management systems in the supply chain is statistically significantly related to the business result (profitability) of the supply chain.

To examine the third hypothesis, a series of multiple regression analyzes was applied. The purpose of these analyzes is to examine the prediction of business results (profitability) of the supply chain based on a set of variables, in this case, the decision to implement intelligent inventory management systems. In the first multiple regression analysis, the independent predictor variables (indicators) were: 1) the intelligent system's application contributes to the competitive advantage of the supply chain, 2) we are satisfied with the existing way of inventory management, and 3) we are gradually introducing intelligent systems into our business activities. The Dependent, criterion variable is - Lower inventory cost. The second multiple regression analysis aimed to examine whether a set of predictor variables describing the introduction of intelligent systems can explain

the dependent variable - Growth in turnover/business income. The third multiple regression analysis examined the extent to which the predictor set of variables describes the criterion variable - A more effective response to market needs.

When looking at the individual contributions, it is clear that the gradual introduction of intelligent systems and competitiveness contribute statistically significantly to the explanation of profitability in the form of lower inventory costs in a positive direction. With the growth of these indicators, the criterion variable grows, meaning greater savings in inventory costs are achieved and thus directly affect the business result of the entire chain.

Respondents give the greatest statistically significant contribution to the growth of business income to the competitive advantage brought by the application of intelligent systems on the market in a positive direction. This implies that with the growth of competitiveness, as a result of the application of innovations, the supply chain can expect a higher volume of traffic. The gradual introduction of intelligent systems into supply chains is at the limit of statistical significance.

The findings indicate that a more efficient response, as a measure of profitability, can be predicted based on the gradual introduction of intelligent systems into business activities. The correlation is positive and statistically significant. With the gradual introduction of intelligent systems in inventory management and clear and precise training of employees at all participants of the supply chain, it is possible to achieve a faster response to the constantly growing needs of the market and consumers.

Based on the conducted regression analysis, it follows that the research hypothesis H3 is accepted and that there is a direct connection between the application of intelligent inventory management systems in the supply chain and the business result (profitability). This relationship is dominantly expressed between 1) the gradual introduction of intelligent systems and competitive advantage with lower costs of inventory management, 2) competitive advantage with growth in turnover (revenue), and 3) the gradual introduction of intelligent

systems in inventory management with a more efficient response to market needs.

## V. CONCLUSION

The need to research the introduction of intelligent inventory management systems in supply chains stems from the fact that it is a growing concept of technology that has an increasingly wide application in practice. Regardless of whether it is global product placement or working with local suppliers, supply chain participants must ensure a high level of quality and safety for their finished products at all times. The greater the visibility in the supply chain and the more effective the communication between the participants, the greater the possibility of more effective management of it. The focus on intelligent systems, fast response logistics, and modern technologies will result in an efficient supply chain with high-quality final products and loyal consumers.

The originality of this research is reflected in the fact that it was determined that the expected benefits from the introduction of intelligent inventory management systems are identical for all participants in the supply chain. Manufacturers, transport companies, wholesalers, and retail companies, regardless of their size, available resources, and the number of employees, all point to the advantages that the application of this business concept brings. However, the differences between participants impose different types of limitations and barriers that they face when implementing intelligent systems. Those barriers should be overcome and a set of measures and incentives should be proposed that the competent ministries, authorities, and associations must define to encourage the introduction of intelligent systems by all participants. The measures should refer to subsidies for the application of intelligent packaging elements, tax reliefs, subsidies for new jobs, free training for employees, subsidies for the gradual digitization of business activities (introduction of IoT, RFID technology), co-financing in the introduction of smart technologies (e.g. Blockchain smart technology as a common, digital platform where supply chain participants can store and share information throughout the chain and review all transactions simultaneously in real-time,

without the possibility of data alteration, hacking or deletion), etc. The use of smart solutions will facilitate inventory tracking and contribute to a more efficient supply chain. In this way, more optimal inventory management is achieved, shortening the time of transportation and delivery of products and improving the efficiency of the entire chain.

#### REFERENCES

- [1] Mentzer, J. T., DeWitt, W., Keebler, J. S., Nix, N. W., Smith, C. D. & Zacharia, Z. G. (2001). *What is supply chain management? Supply Chain Management*, Sage Publications, Thousand Oaks, CA, (pp.5-62).
- [2] Yanamandra, R. (2019). *A Framework of Supply Chain Strategies to achieve competitive advantage in Digital era*, IEEE Xplore Digital Library.
- [3] Witasari, J & Gustomo, A. (2020). Understanding The Effect of Human Capital Management Practices, Psychological Capital, and Employee Engagement To Employee Performances. *The Asian Journal of Technology Management (AJTM)* 13, 1-15.
- [4] Kelly, R. Jr. & Efraim T. (2009). *Uvod u informacione sisteme*, Beograd, Data Status.
- [5] Ravi, K., Tarun, K. A., Jan, O., Magnus, W. & Jannicke, B. H. (2022). Supply chain visibility for improving inbound logistics: a design science approach. *International Journal of Production Research*.
- [6] Lysons, K. & Gillingham, M. (2006). *Purchasing and Supply Chain Management*. 7th Edition, Pearson Education Limited, Edinburgh, UK.
- [7] Toyoda, K., Mathiopoulos, P.T., Sasase, I. & Ohtsuki, T. (2017). A novel blockchain-based product ownership management system (POMS) for anti-counterfeits in the post supply chain. *IEEE Access*, 5, 17465-17477.
- [8] Maksimović, M., Vujović, V. & Omanović-Miklićanin, E. (2015). Application of internet of things in food packaging and transportation. *International Journal of Sustainable Agricultural Management and Informatics*, 1(4), 333-350.
- [9] Ash, C.G. & Burn, J.M. (2003). A strategic framework for the management of ERP enabled ebusiness change. *European Journal of Operations Research*, 146, 233-240.
- [10] Erceg, A. & Damoska-Sekuloska, I. (2018). *E-logistics and e-scm: How to increase competitiveness*.
- [11] Min, H. (2009). Artificial intelligence in supply chain management: theory and applications, *International Journal of Logistics Research and Applications*, 13, 13-39.
- [12] Vučenović, S. (2018). Internet of Things as innovative technology in retailing. *Anali Ekonomskog fakulteta u Subotici*, 54(39), 249-256.
- [13] Lee, H. L. & Whang, S. (2000). Information sharing in a supply chain. *International Journal of Technology Management*, 20(3/4), 373-387.
- [14] Ramaa, A., Subramanya, K.N. & Rangaswamy, T.M. (2012). Impact of Warehouse Management System in a Supply Chain. *International Journal of Computer Applications*, 54(1), 14-20.
- [15] Hasani, M (2018). *Wearable Passive RFID Tags in Advanced Applications: Detection Methods for RFID-Enabled Sensor Tags and RFID-based Localization*. PhD thesis. Tampere: Tampere University of Technology.



# Crises and Innovations in Tourism - Development of Creative Tourism

Snežana Štetić<sup>1</sup>, Igor Trišić<sup>2</sup>

<sup>1</sup>Balkan Network of Tourism Experts, Belgrade, Serbia

<sup>2</sup>Faculty of Geography, University of Belgrade, Belgrade, Serbia

<sup>1</sup>snezana.stetic@gmail.com, <sup>2</sup>trisici@hotmail.com

**Abstract**—Crises that arise on a global level affect all activities, including tourism. The COVID-19 epidemic threatened the total collapse of the tourist market. At the beginning of the epidemic, tourist movements were slow, but fortunately, such hints did not come true. Tourism has taken a new direction and is starting a new phase of its development. What is characteristic of that phase are the innovations of tourist products with the aim of strengthening tourist destinations. New forms of tourism that influence the redistribution of tourist movements and the creation of new tourist destinations play a special role in this. This is how new tourist products are created that satisfy tourist demand on the foreign and domestic tourist markets. This paper studies the development of creative tourism, recognizing the potential that exists for the demand for this type of tourism. This is especially expressed through the participation of tourists and their active interaction with the local population, as well as the connection with culture and nature. All this affects the authenticity of the trip, which is required by this segment of tourist demand.

**Keywords** - crises, innovations, creative tourism, specific tourism forms, culture, tourism development

## I. INTRODUCTION

Tourism is most often motivated by the desire to get to know new destinations, cultures, gastronomy and other positive experiences provided by tourist trips. Participating in foreign or tourist trips leads to the interaction of tourists, local residents and the local community as a whole. In this way, the quality of life of all participants increases. Also, it leads to both innovation and the risks that arise. That is why these paper deals with the positive and negative

aspects of such interactions with an emphasis on the positive impact on the local environment by creating new types of tourism.

In 2019, tourism achieved exceptional results in its development in terms of the number of tourists, number of overnight stays and foreign exchange inflow. In contrast, COVID-19 almost completely stops tourist trips during 2020. In 2021, in some countries, the population ignores the risk of disease and starts traveling. Tourists are turning to domestic destinations and shorter trips. Domestic tourism trends in Serbia had extremely positive effects on the development of domestic tourism and rural parts of the country. Already in February 2022, tourism is facing a new risk, which again affects tourism and tourist trips. Both the mentioned medical risk and the new war conflict affect the world economy, the daily life of the population as well as tourism. This is precisely what shows us how vulnerable tourism is to all negative events both globally and locally. The beginning of the third decade of the twenty-first century confirmed the need to think about security and to respect it.

Precisely different risks very often affect a number of innovations that take place in the tourist markets. The reason for this is the perception of risk, which differs among people and which affects their desire to travel differently. The tourist market is constantly looking for something new and something innovative. Also, the modern understanding of innovation refers to all areas of human creativity, including the non-economic area of life where new solutions are discovered and applied that in their own way improve the quality of people's lives [1]. With innovations,



there is always the question of whether something new has been done. In tourism, the question is whether new forms of tourism contribute to the development of the destination. From a theoretical point of view, innovations appear in three basic ways: as incremental (small and gradual); as architectural (which more significantly restore existing technology) and discontinuous (bringing a completely new approach).

Creative tourism as a concept is based on an authentic experience, the manifestation of the creative potential of an individual, and the independent creation of experiences in tourism. Modern tourism is characterized by a shift in focus from material to immaterial resources, especially those that make up the identity of a tourist destination [2]. As a rare resource, creativity can precisely contribute to profiling that unique and recognizable identity, in which case the serial reproduction of culture and the appearance of unified, typical spaces for its passive consumption is avoided.

Focusing on the non-traditional use of the destination's cultural potential, creative tourism tries to overcome the problems of overdevelopment, lack of investment, overcrowding, homogenization, and unrepeatability that cultural tourism has suffered in recent years. From an economic point of view, creative tourism is considered a development weapon for improving the national economy, regions, and cities, stimulating local development, and preventing youth migration, depopulation, and lack of economic resources [3]. This form of tourism is a relatively new term that denotes specific tourist trips with activities that are not only closely related to cultural tourism but also to nature tourism [4].

The objectives of this paper are: to investigate and examine the concept and importance of risks an innovation in tourism and specially creative tourism in today's tourism market. As part of the analysis, the significant impacts of creative tourism on the development of destinations will be examined. The main task of this work should be to examine to what extent creative tourism is present in the tourism market and what the roles of tourists and local residents are in these movements. The study has used a qualitative method of analysis and synthesis of published research results.

Tourists want to spend free time in a way to satisfy some of his inner needs: to acquire new

knowledge, for creative work, hobbies, and to get to know other people's traditions and ways of life. For that reason, a special tourist offer is being developed in destinations. The form of cultural tourism that is realized in this kind of supply and demand is called creative tourism [5].

## II. INNOVATION AND CREATIVITY

Creating the concept of innovation as the driving force of economic and overall social development affects the understanding of the importance of innovation for the development of the tourist market [1]. Ideas are the basis of business, which is very important in tourism for its creation and further development. The modern development of tourism expects new activities that influence the creation of different tourist products. This is exactly why creativity is extremely important for the creation of new products in tourism and its growth and development. Technological and social innovations influence the creation of an increasing number of special forms of tourism.

The traditional approach to creativity research has referred to creativity as something made by creative people. Unlike the traditional ones, the modern approach assumes that occasionally all people are able to produce at least moderately creative work in some domain and that the social environment can influence both, its level and frequency [6]. Also, in fields such as psychology or design, creativity is viewed from the artist's perspective [7]. Connecting the concept of creativity with today's tourism is a complex task [7].

The concept of creativity can be viewed from several dimensions, such as: everyday creativity, artistic creativity, and intellectual creativity [8]. The convergence between creativity and tourism lies in the dimension of everyday creativity [9], since both terms are related to everyday life. Tourists want to participate in the acts of everyday creativity, which are closer to the circumstances of their real life [10].

Ivčević and Maier [11] categorized 121 items into the following five categories of everyday creativity: craftsmanship, cultural sophistication, self-expressive creativity, interpersonal creativity, and sophisticated media consumption. According to Hung et al. [12], creative experience contains three factors: a sense of achievement, unique learning, and

interaction with educators. However, Tan et al. [7] specifically investigated creativity within the creative experience and concluded that creativity exists through novelty, utility, controlled risk, experiential items, and existential needs.

To be creative in the modern world means to be specific, acceptable in a special way, and most importantly, to be new and different, by which one should distinguish oneself from the competition [13]. The author singles out different dimensions and qualities of creativity:

- creativity generates images, ideas, and solutions;
- creativity is the process of developing unique, new, and unusual ideas;
- it involves the use of imagination and experience of thinking;
- creativity includes the ability to select, and combine existing ideas, facts, images, and skills in an original way.

Considering creativity and tourism from another aspect, we can notice an increasing number of creative companies that are looking for new markets for their accessibility and development.

### III. CRISIS AND CREATIVITY IN TOURISM

Tourism is an extremely vulnerable activity. It is subject to various influences, both positive and negative [14]. The latest events (medical risks, political turmoil and war actions, economic crises, natural disasters) directly affect tourism and redistribution of tourism at the global level.

Understanding the characteristics of the tourist market and the constant changes in tourist demand is extremely important in overcoming crises that can affect tourism development. One of the ways to overcome the weaknesses in the tourist offer is to consider new ways of creating tourist products. In order to achieve this, the creativity and innovation of tourism employees is extremely important.

The term “creative tourism” was defined by Richards and Raymond [15], who linked it to promoting craft production in tourism. This definition involves the key principles of creative tourism: it provides opportunities for personal creative development, increases engagement by allowing visitors and their hosts to create

together, and connects creative activities with the destination. Creativity could be expressed most adequately through crafts as the economic sector closely related to tourism. Domestic handicrafts, local industry, folklore and culture are the ideal places to encourage creativity in tourism.

Creativity has become widely applied in several industrial and artistic fields, especially in the creative and cultural industries [16]. Creative tourism is arising as a key development option for various reasons and can serve specific purposes. First, it responds to the need to reinvent tourism, as well as the need for destinations to do something different in a saturated market. It can also satisfy tourists' desire for more fulfilling and meaningful experiences, linking to an active tourist stay [17]. Creativity is becoming an increasingly popular career option for new businesses that desperately need new markets. The popularity of creative practices such as music, dance, and photography are also on the rise. Up-to-date trends in tourism needs explain and justify the popularity of more and more creatively developed tourist offers to some extent [18].

Creative tourism can be defined as a form of cultural tourism that, gives a new dimension that will satisfy the needs of the modern tourist for creativity and stay in the destination to experience the true atmosphere of the area. Every destination can be creative, and develop creative tourism and enable the development it to attract tourists.

Cultural and creative tourism are similar. The main difference between cultural and creative tourism is that the former often involves tour groups traveling with a guide who interprets the culture for them, while the latter involves tourists actively learning about the environment and seeking more engagements of their own [7].

According to UNESCO, creative tourism is travel aimed at an engaged and authentic experience with participatory learning about the art, heritage, or special features of a place, and it provides a connection with the local population that participates in the creation of local culture [19].

#### IV. EXISTING MODELS OF CREATIVE TOURISM DEVELOPMENT

Richards and Raymond [15] emphasize that not only tourists should be involved in creative activities, but that destinations must also offer typical experiences. Creativity is an important part of the destination. Each target destination can offer a unique combination of knowledge, skills, tangible heritage, social capital, and atmosphere that creates the potential for an extremely attractive creative person. This uniqueness can be linked to local traditions. According to the same source, there are two forms of creative tourism:

a) Creative tourism related to a specific target destination. If they follow this approach, cities and municipalities are creative. Tourism operators use the image of creative cities and municipalities to increase the attractiveness of their products.

b) Creative tourism based on creative activities. This approach follows the assumption that creative tourism products are spatially diffuse and based on creative activities in which tourists can participate in different places independent of location.

The creative industry plays an increasingly important role in tourism development with a particular impact on the destination image. For example, we can mention the places where the films *The Lord of the Rings* (New Zealand) and *Harry Potter* (Great Britain) were shot. Today, a form of music tourism that includes trips to music festivals and concerts is also widely popular. When creating a tourism offer, the cooperation between producers and consumers is in focus. The growth of creative tourism marks a shift toward a more specific approach to creativity in tourism, and it is found both in rural and urban areas applying various development strategies.

Creative tourism has the potential to utilize local skills, professionalism, and traditions from many fields [20]. For example, creative tourists may want to learn about:

- art - art exhibitions and workshops are essential motives for tourists who prefer active tourist vacations;
- design - local workshops and craft factories as part of the tourism offer are closely related to getting to know and

learning about the design of pottery, paintings, art objects, and textiles [21];

- gastronomy - learning about gastronomy and eating habits of certain peoples is a significant tourist motive. The desire to try authentic national food, a local gastronomic brand or product;
- health and recreation;
- languages and culture;
- spirituality and customs;
- nature; and
- sports.

All these creatively based products represent major growth areas in tourism at the moment and probably in the future. The greatest advantage of creative tourism for a destination is that it provides a new means of differentiating its cultural products from those of the competition. The reason for this lies precisely in the term through which creative tourism is described in practice as tourism that offers visitors the opportunity to develop their creative potential through active participation in courses and learning experiences that are characteristic of the holiday destination they are in [22].

#### V. CREATING DIFFERENT PLACES

Creative resources are used as a “hallmark” of certain cities and regions that distinguish them from others. Today, there is an increasing focus on intangible cultural heritage due to the fact that cities have fewer and fewer resources that should constitute tangible cultural heritage. Cities must adapt to the global market and, for this reason, use creative and cultural resources to launch their own tourism brand.

If the potential learning opportunities are analyzed as part of creative tourism, it can be concluded that, in practice, creative tourism is closely related to tourists’ specific interests. Tourists’ different needs and interests have resulted in the creation of various specific forms of tourist movements. In addition to the fact that creativity is closely related to culture, a deeper analysis can confirm a connection between nature and activities that use natural resources for the development of specific tourism forms.

When conceiving the current offer of creative tourism, the essential role is played by

tourist destinations. The way of planning the development of creative tourism in practice must be such that cultural and natural resources and the life of the local community are not damaged. According to Richard and Wilson [23], an important implication for tourism destination managers should be that creativity is an attribute to both, a production process as well as a consumption process. Creative tourism must involve the creative use of resources to provide creative experiences for tourists.

In the world tourism market, well-known cultural destinations are increasingly developing various forms of creative tourism, such as the city of Santa Fe in New Mexico, in the areas of art, culture, and heritage. Santa Fe Creative Tourism is a program that offers a wide range of creative tourism experiences, from traditional sewing to landscape painting, pottery, and 3D printing. Santa Fe's reputation as a creative place helps to attract many visitors who desire to be engaged in creative activities, which, in turn, strengthens the city's cultural life and branding [24].

New Zealand is a well-known creative tourism destination that offers the development of creative workshops and courses that focus on tradition and heritage. The basic orientation of many creative tourist programs here can be summed up in Confucius' saying: "I hear and forget. I see and remember. I do and understand". This was the underlying philosophy of the Creative Tourism New Zealand Programs. This approach emphasizes creative activity as a means of engaging participants and developing links between producers and consumers [25].

Creative tourism is a social, cultural, and ecological phenomenon. It includes creative practices, experiences, and personal encounters with local communities and individuals. This means that the basic feature of mobile tourism is the creation of different tourist places, which distinguish in their content and function. Service design directly affects the creation of a destination's image [26].

The Emilia Region (Italy), with its 172,124 inhabitants, is one of the eight capital cities of the Italian region Emilia-Romagna. This region combines a rich rural landscape with densely populated villages, and it offers a variety of sites of natural, historical, and socio-cultural importance for travelers who want to experience the authentic Italian way of life. Creative

tourism is a symbol of this part of Italy. Similar examples are noted in Obidos (Portugal), Cesky Krumlov (Czech Republic), Jyväskylä (Finland), and York (Great Britain) [27]. A key aspect of creative tourism is the opportunity, which really allows the participation and creation of something new. Similar examples are noted all over the world: Barcelona (with the conference on creative tourism), Creative Austria (the program in Austria that offers a variety of creative experiences), Paris (a creative destination offering workshops and courses in many fields).

Lesser-known cultural destinations also direct their offer toward creative tourists and offer a number of different activities to contribute to a stronger interest of tourists in order to strengthen the competitiveness of the tourist destination with such development [28].

#### A. *Perspectives of creative tourism*

The importance of creative tourism in practice can be significant for the following reasons [29]:

- through creative tourism, tourists get an experience with a higher level of satisfaction compared to tourist movements that offer visits to interesting places related to art or culture;
- creative tourism offers visitors the opportunity to evaluate nature and the life of the local population thoroughly;
- vacation with creativity arouses a feeling of contact with something new and gives the opportunity to acquire new skills;
- visitors are increasingly looking for an opportunity to draw a line between their dynamic everyday life and the satisfaction of another way of life; they achieve emotional intensity by creating their own memories.

Creative tourism has a number of potential advantages over traditional forms of tourism [20]:

- it can be more sustainable than traditional forms of cultural or heritage tourism since it is based on intangible resources;

- the need for infrastructural investments in creative tourism is often less since it does not depend on physical structures;
- creativity is a mobile resource also present in all locations and social strata;
- creative tourism promotes interaction between local residents and visitors.

In addition to the fact that the tourist expansion of creative tourism changes the habits of tourist demand. The focus in the tourism industry is shifting from sightseeing to learning about life [20] which refers to tourists' desire to immerse themselves in the diverse local cultures on offer. Today's travelers want to move away from the formal tourism industry [30], and enjoy interacting with local community representatives.

Among numerous perspectives of creative tourism, we can single out the following [31]:

- adequacy to the new demands of tourists who want a unique experience;
- achievement of the offer diversification without investment;
- the accomplishment of positive effects and profitability of cultural infrastructures;
- organization of quality tourism with high added value and purchasing power;
- achievement of tourism non-seasonality, which enables better distribution;
- geographic outsourcing: less interest of creative tourists in classic tourist hotspots;
- the increase of the self-confidence of the local population;
- strengthening of communities and accomplishment of professionalization;
- achievement of social cohesion through the co-creation of a products;
- realization of sustainability, which relies on authenticity and creativity as the crucial resource;
- restoration of intangible heritage;

- the implementation of a destination management tool.

For tourists, creative tourism can develop a more active and long-lasting form of experience, while for the destination, it represents an opportunity to express the experience in the local. It can include the creative use of inherited and created resources, whose combination will produce recognition and a reason for tourists to choose an experience exactly in that specific destination. The most significant implication is to recognize the creative potential of tourists.

The perspective of creative tourism is closely related to creating a tourism offer that implements various specific forms of tourism. In the first place, the connection with cultural forms of tourism. In rural destinations, the importance of creative tourism is reflected in the event, wine, gastronomic and ethnic tourism [32]. These forms of tourism are based on familiarization with local culture, language, handicrafts, original folk melos, cultural heritage, customs etc.

Creativity can be a strategy in creating a tourism destination and brand, with cities and regions looking to increase their attractiveness to the creative tourism, support creative industries, or become 'creative'. In carrying out numerous strategies for tourism development, we can notice a shift of concentration from creative individuals to creative areas, places, or regions. Numerous completed case studies on creative development indicate that these strategies must be sensitive to the local context and follow some basic principles of design in culture and art [33].

## VI. CONCLUSION

Creative resources are used as a “hallmark” of certain cities and regions that distinguish them from others. Today, there is an increasing focus on intangible cultural heritage due to the fact that cities have fewer resources for cultural heritage. Cities must adapt to the global market; that is why they use creative and cultural resources to build a brand. As a concept, creative tourism is based on an authentic experience, the manifestation of the creative potential of an individual, and the independent creation of experiences in tourism. Contemporary tourism is characterized by a shift in focus from material to immaterial resources, especially those that make up the

identity of a tourist destination. Bearing in mind the impact of risk on tourism as well as innovation on its development, in this work we have laid the basis for further research in this area through creative tourism. As a scarce resource, creativity can precisely contribute to profiling that unique and recognizable identity while avoiding the serial reproduction of culture and the appearance of typical spaces for its passive consumption. The concept of creative tourism is suitable for both urban and rural areas; the essence is in the use of “raw” material and the creation of a unique experience. Creative tourism arose as a reaction to cultural tourism and refers primarily to creative consumers who, unlike cultural tourists, are increasingly looking for interactive experiences that help them in personal development and identity creation by increasing their own creative capital. Creative tourism offers visitors the opportunity to develop their creative potential through active participation in experiences taking place in vacation destinations through which they can learn something new. The offer of creative tourism is closely related to different specific forms of tourism. Firstly, the connection with cultural forms of tourism points out, such as artistic, theatrical, cultural-historical, religious, film, fashion, and other forms. Secondly, in rural destinations, the importance of creative tourism is reflected in the event, wine, gastronomic and ethnic tourism. These forms of tourism are based on familiarization with the local culture, language, handicrafts, original folk melos, language, cultural heritage, customs, etc.

If the research results collected and presented in this paper are analyzed, it can be concluded that creative tourism has direct links with cultural forms of tourist movements. Unlike cultural tourism, in creative tourism as a specific form, the role of the guest and host differs in many ways. Tourists are more active; they are not often passive observers and listeners like classic visitors. In creative tourism, the resident population plays an active role as instructors and teachers about their environment, culture, and lifestyle. Simply, members of the local community have the task of educating visitors in the best possible way about all the ethnic-social and natural values of the destination. Consumers of creative tourism participate actively in learning about the life and culture of the people of particular destinations, and the style and way of life. They can take part

in home craftsmanship, and folklore; they can also learn about eating habits, customs, and artistic styles that characterize certain peoples, the relationship of man to nature, and many other factors that condition these tourist movements. More and more sophisticated needs of tourist demand characterize today's tourism [34]. Tourists are increasingly departing from classic vacations and turning to special interests [35]. Creative tourism synthesizes various specific forms of tourism, engages more active participation of tourists and residents, and stimulates mutual interaction. It also affects the spread of culture, customs, and creativity and encourages the protection of nature and its values. We can conclude that creative tourism can play a significant role in future tourist flows worldwide.

#### REFERENCES

- [1] Pokrajac, S., & Štetić S. (2017). *Osnovi menadžmenta sa primerima iz turizma*. Beograd: Visoka turistička škola.
- [2] Couret, C. (2020). Creative tourism—providing the answers to a more inclusive society. *Worldwide Hospitality and Tourism Themes*, 12(6), 747-751.
- [3] Huang, Y., Chang, L.L., & Backman, K.F. (2019). Detecting common method bias in predicting creative tourists behavioural intention with an illustration of theory of planned behaviour. *Current Issues in Tourism*, 22(3), 307-329.
- [4] Al-Ababneh, M. (2020). Creative cultural tourism as a new model of the relationship between cultural heritage and tourism. *International Journal of Hospitality and Tourism Studies*, 1(1), 39-44
- [5] Lai, S., Zhang, S., Zhang, L., Tseng, H. W., & Shiau, Y. C. (2021). Study on the Influence of Cultural Contact and Tourism Memory on the Intention to Revisit: A Case Study of Cultural and Creative Districts. *Sustainability*, 13(4), 2416.
- [6] Mishra, L.K., & Singh, A.P. (2010). Creative Behaviour Questionnaire: Assessing the Ability of Managers to Produce Creative Ideas. *Journal of the Indian Academy of Applied Psychology*, 36(1), 115-121.
- [7] Tan, S.K., Kung, S.F., & Luh, D.B. (2012). A model of ‘Creative Experience’ in creative tourism. *Annals of Tourism Research*, 41, 153-174.
- [8] Richards, G. (2016). *Cultural attractions and European tourism*. Wallingford: CAB International.
- [9] Richards, G. (2011) Creativity and tourism: The state of the art. *Annals of Tourism Research*, 38(4), 1225-1253.
- [10] Tan, S.K., Tan, S.H., Luh, D.B., & Kung, S.F. (2015). Understanding tourist perspectives in creative tourism. *Current Issues in Tourism*, 19(10), 981-987.
- [11] Ivcevic, Z., & Mayer, J.D. (2009). Mapping dimensions of creativity in the life-space. *Creativity Research Journal*, 21, 152-165

- [12] Hung, W.L., Lee, Y.J., & Huang, P.H. (2014). Creative experiences, memorability and revisit intention in creative tourism. *Current Issues in Tourism*, 19(8), 1-8.
- [13] Heller, R. (2004). *Priručnik za menadžere*. Zagreb: Profil International.
- [14] Štetić S. (2012). Risk management in Tourism. 1st Belgrade International Tourism Conference BITCO, Beograd.
- [15] Richards, G., & Raymond, C. (2000). Creative tourism. *ATLAS News*, 23, 16-20.
- [16] Wurzburger R., Ageson T., Pattakos A., & Pratt S. (Eds.) (2010). *A Global conversation. How to provide unique creative experiences for travelers worldwide*. Santa Fe: Sunstone Press.
- [17] Maitland, R. (2010). Everyday life as a creative experience in cities. *International Journal of Culture, Tourism and Hospitality Research*, 4(3), 176-185.
- [18] Richards, G., & Marques, L. (2012). Exploring creative tourism: editors introduction. *Journal of Tourism Consumption and Practice*, 4(2), 1-11.
- [19] UNESCO, (2006). Towards sustainable strategies for creative tourism. *International Conference on Creative Tourism*, Santa Fe, New Mexico, USA.
- [20] Richards, G. (2017). The challenge of creative tourism. *Ethnologies*, 38(1-2), 31-45.
- [21] Tan, S.K., Luh, D.B., & Kung, S.F. (2014). A taxonomy of creative tourists in creative tourism. *Tourism Management*, 42, 248-259.
- [22] Bonink, C., & Hitters, E. (2001). Creative industries as milieu of innovation: The Westergasfabriek, Amsterdam. In G. Richards (Ed.), *Cultural Attractions and European Tourism*. Wallingford: CAB International.
- [23] Richards, G., & Wilson, J. (2006). Developing creativity in tourist experiences: A solution to the serial reproduction of culture? *Tourism Management*, 27, 1209-1223..
- [24] Hanifl, B. (2015). *What is the economic value of creative tourism in Santa Fe, New Mexico?* MA Thesis, Degree of Masters of Science in Arts Management, University of Oregon.
- [25] Raymond, C. (2007). Creative Tourism New Zealand: The practical challenges of developing creative tourism. In G. Richards and J. Wilson (Eds.), *Tourism, Creativity and Development* (pp. 145-157). London: Routledge.
- [26] Sarantou, M., Kugapi, O., & Huhmarniemi, M. (2021). Context mapping for creative tourism. *Annals of Tourism Research*, 86, 103064.
- [27] Tomaz, E. (2021). The interplay between culture, creativity, and tourism in the sustainable development of smaller urban centres. In K. Scherf (Ed.) *Creative tourism in smaller communities* (pp. 61-78). Calgary: Thompson Rivers University.
- [28] Wilson J., & Richards, G. (2007). *Tourism, creativity and development*. London: Routledge.
- [29] Robinson, M. (2017). The power to define: meanings and values in cultural tourism. Reflections on International Tourism: Expressions of Culture, Identity and Meaning in Tourism (Business education publishing).
- [30] Steylaerts, V., & Dubhghail, S. (2011). Couchsurfing and authenticity: notes towards an understanding of an emerging phenomenon. *Hospitality & Society*, 1(3), 261-278.
- [31] Jelinčić, D.A., & Žuvela, A. (2012). Facing the challenge? Creative tourism in Croatia. *Journal of Tourism Consumption and Practice*, 4(2), 78-90.
- [32] Trišić, I., Štetić, S., Privitera, D., & Nedelcu, A. (2020). Wine routes in Vojvodina Province (Northern Serbia): A tool for sustainable tourism development. *Sustainability*, 12(1), 82.
- [33] Richards, G. (2020). Designing creative places: The role of creative tourism. *Annals of Tourism Research*, 85, 102922.
- [34] Štetić, S., & Šimičević, D. (2015). *Tourism Geography* [in Serbian: Turistička geografija]. Beograd: Visoka turistička škola strukovnih studija.
- [35] Trišić, I., Štetić, S., Maksin, M., & Blešić, I. (2021). Perception and satisfaction of residents with the impact of the protected area on sustainable tourism: The case of Deliblatska Peščara Special Nature Reserve, Serbia. *Geographica Pannonica*, 25(4), 317-325.

# Web Scraping Analysis: Gender Differences in Local Online Media Mentions

Bojan Baškot<sup>1</sup>, Maja Barišić<sup>2</sup>

<sup>1</sup>Faculty of Economics, University of Banja Luka, Banja Luka, Bosnia and Herzegovina  
<sup>2</sup>Sarajevo, Bosnia and Herzegovina

<sup>1</sup>bojan.baskot@ef.unibl.org, <sup>2</sup>maja.barisic@edu.uni-graz.at

**Abstract**—This paper focuses on the comparison of media mentions of male and female candidates in the electronic media in a selected sample of Local Self-Government Units (LSGUs) in the Federation of Bosnia and Herzegovina during the pre-election campaign for the 2020 Local Elections. The idea was to investigate the differences in the frequency of appearance of female and male candidates in local online media. Hence, the focus was on local news portals and local public Facebook pages. For this analysis, data were collected primarily using software tools available in the R programming environment and Python. The results of the web scraping exercise are collated with data on candidates from the Central Election Commission (CEC). The analysis reflects on the candidates for the mayor and for the city and municipality council. Additionally, data are disaggregated across gender

**Keywords** – web scraping, text analysis, gender mainstreaming in politics

## I. INTRODUCTION

Media and electoral legislation in Bosnia and Herzegovina prohibit discrimination and stereotypical or offensive content during pre-election campaigns. However, the existing legal framework does not regulate the gender balanced or proportional representation in pre-election media content. Further, the BiH print and online media self-regulatory acts do not address the issue of equal or proportional representation of male and female candidates either. Although government non-interference in media content creation and selection of interlocutors is crucial for media freedom, pre-election campaign media

content is regulated to secure basic equal conditions for all candidates. Still, gender parity or proportionality in pre-election media content is not codified in BiH.

Gender mainstreaming in local self-government requires integration of gender perspectives in local decision making. Ensuring that women's (and other groups') perspectives are integrated leads to better quality local policies. For example, taking into account the problems of women handcrafters active in the informal economy when developing a local tourism strategy can, in ideal conditions, improve the local tourism offer and provide better conditions for paid pension contributions, thereby preventing old age poverty. While proportional representation of women in local decision-making bodies may not be sufficient to integrate women's (and other groups') perspectives in decision making, it is still necessary. The BiH Law on Gender Equality (BiH OG 32/10) requires minimum 40 percent representation of men and women in all decision making bodies at all governance levels. The BiH Election Law (BiH OG 31/16) applies the same 40 percent quota for electoral lists of candidates and prescribes the ordering. Enforcement of quotas in the electoral lists is satisfactory – the Central Election Commission does not confirm lists of candidates which do not meet the requirement. Still, only around 19 percent of local councillors and four percent of mayors elected in the 2016 Local Elections in BiH were women. Analysts and politicians often blame voter prejudice.



Gender equality institutions in BiH have tried to influence voter prejudice in earlier election cycles to little avail. Public campaigns against prejudice typically employ a direct-message approach – “Vote for women!” or “We are equal!” Such paid advertisements or videos are, by rule, placed out-of-context – they are not aired during political talk-shows or within journalist content, but rather in air times and space reserved for promotional messages. By default, such content is less effective than subtle nudges and incentives. The nudge theory suggests that social attitudes and behaviours are more likely to change if a normative approach is supplemented, or in some cases, replaced by incentives and subtle messages [1]. Another problem with government-driven marketing campaigns against voter prejudice in BiH is that they commonly rely on the public broadcasting system and publicly funded local media they have easier access to, while ignoring most private media and nearly all online media.

This paper considers an explanation complementary to voter prejudice – women have limited access to media in pre-election campaigns because the media market is prejudiced and prioritises candidates who are already influential or controversial – women candidates rarely belong to either of those categories. The paper focuses specifically on online media which are underregulated in BiH, while being increasingly influential.

This study collected the online media content produced by 46 online media portals and 5 Facebook pages during one month of pre-election campaigning ahead of the 2020 Local Elections in a sample of 42 LSGUs in FBiH. The content was then analysed checking for online media mentions of 1,222 candidates from those LSGUs in the 2020 Local Elections.

The next section contains an explanation of applied data-collecting methods and techniques in the R programming environment, followed by a brief literature review. The results section presents quantitative indicators, followed by a discussion, and concluding observations.

## II. DATA AND METHODOLOGY

### A. Data

Initially, 41 out of 78 LSGUs from FBiH which held local elections on 15 November 2020 were sampled. The City of Mostar held the elections on 20 December 2020 and we added it to the sample subsequently. We sampled the

LSGUs (except Mostar) randomly within three groups formed depending on the size of local councils, i.e., the number of mandates. In the final sample of 42 LSGUs, 13 were from small local councils with 11-19 councillors, 15 were from medium-sized councils counting from 21-25 councillors, and 14 (including Mostar) with large councils with 27 mandates and higher. Cantonal distribution was not taken into account during sampling – the number of LSGUs varies significantly by canton.

Due to the large number of candidates who participated in the elections, we narrowed the analysis down to 1,222 individuals from these 42 LSGUs, selecting them by the following criteria:

1. the first and the second person in each list of candidates for regular council mandates, resulting in 1,046 individuals (564 men and 482 women);
2. all mayoral candidates (136 candidates: 129 men and 7 women);
3. candidates for mandates reserved for national minorities (40 persons: 33 men and 7 women);
4. all independent candidates for councillor, mayors, and minority mandates (outside party, coalition, and independent lists) (60 persons: 48 men and 12 women).

Categories 3 and 4 overlap as minority candidates can run independently or on party lists (the sum of categories listed above is higher than 1,222).

We included all online media reporting from the 42 LSGUs in the online content database. In some LSGUs, however, no such web portals existed, while some of the media from larger LSGUs covered a wider territory, and several media web portals of country-wide influence were included. Finally, we downloaded the contents of 46 media web portals and five public Facebook pages.

During the pre-election campaign period from 14 October – 14 November 2020, 42,107 texts were collected from the media web portals, while the selected Facebook pages proved irrelevant in all areas except in Posavina Canton, where Facebook was one of the rare local sources of information about the elections. That specific source mentioned exclusively male candidates. For Mostar pre-election campaign from 19

November – 19 December 2020, the sample included 5,993 articles from local media web portals, and additional 1,000 articles from the most influential web portal in the country.

### B. Methodology

We used Feedly to collect and sort data from the selected online media. Packages in the R programming environment allowed us to sort and analyse data. This approach enabled us to scrape and analyse content retroactively, except for portals that prevent web crawling. The content was collected in HTML format, and then refined and systematized with *stringr*, *tydeverse* and other R packages. In addition, Python’s packages *Beautiful Soup* and *Selenium* were used to download content related to open Facebook pages, as Facebook introduced significant restrictions to data scraping from 2018.

First, the selected web portals were added in Feedly, which has an API that allows R access to web portals’ content. *An OAuth Dance Authentication* is required for this process (Fig.1).

All the populated content was analysed in R utilizing the *ndoc*, *n token*, *n type*, and *nsentence* functions. This part of the analysis focused on the candidates’ names, to narrow down the content which mentions candidates.

While LSGUs were not sampled randomly within cantons but within size groups, cantons are still relevant for the overall media landscape

```

feedly_access_token()

.pkgenv <- new.env(parent=emptyenv())
.pkgenv$token <- Sys.getenv("FEEDLY_ACCESS_TOKEN")
.feedly_token <- function() {
  return(.pkgenv$token)
}

feedly_stream <- function(stream_id, ct=100L,
  continuation=NULL) {

  ct <- as.integer(ct)

  if (!is.null(continuation)) ct <- 1000L

  httr::GET(
    url = "https://cloud.feedly.com/v3/collections",
    httr::add_headers(
      `Authorization` = sprintf("OAuth %s",
        .feedly_token())
    ),
    query = list(
      streamId = stream_id,
      count = ct,
      continuation = continuation
    )
  ) -> res

```

Figure 1. OAuth Dance Authentication in R

in each municipality. This is why candidate mentions were screened within all content produced inside each canton.

Next, a qualitative analysis was conducted by defining candidate names as tokens (*tokenization* refers to splitting of a text into sequences of several words or *N-grams*).

### III. LITERATURE REVIEW

Symbolic politics theory suggests that humans adopt certain latent political values through socialisation, while these general orientations get activated later in life as affect and attitudes through political symbols [2]. These latent values influence also the voting behaviours. How and which attitudes and behaviours are activated, largely depends on the political and media influences. Framing theory suggests that framing of issues by politicians, media, and the advertising industry influences individual preferences at this unconscious level, while the abundance of accessible personal data about nearly every individual present online today enables also for personalisation of political messages, manipulation of voter attitudes and behaviours [3], and stumps individual voter autonomy, as the Cambridge Analytica case shows [4].

The online media web portals and social media platforms serve multiple functions in this context. They provide space for political stakeholders to frame political issues and convey cues for activation of latent political values, while at the same time collecting personal information about audiences – traditional press, radio, and television cannot provide the latter. Still, online media have also expanded the individual freedom of speech. Another function of these online sources is to inform scholarly analysis of political processes using statistical and econometric methods.

R as a programming environment can make an immeasurable contribution in terms of efficiency when solving seemingly overwhelming problems related to political science research (too extensive in terms of data to be processed) [5-10].

In a broader context, we can understand this specific exercise as part of the increasing use of quantitative, statistical, and econometric methods in the study of political processes [11-14].

Web scraping and content analysis, aligned, give significant contributions to the existing literature in political science [15-18].

Earlier studies focusing on descriptive and substantive representation of women in online sphere have applied similar approaches. A Gender Gap Tracker in Canada presents results of a continuous daily process of web scraping of Canadian English language media and Natural Language Processing to track quotations of men and women in the scraped content, documenting frequencies and patterns [19]. Women candidates' online web pages and biographies are also analysed using a combination of web scraping and content hand coding [20].

#### IV. RESULTS

For each selected LSGU, we calculated the average number of mentions for male and female candidates in the sampled online media content within that canton. Incidence of mentions was further disaggregated to types of mandates candidates competed for.

Each candidate's name and surname were searched in all the content scraped from the entire canton the municipality belongs to. Consequently, results are incomparable between cantons, as well as between LSGUs from different cantons, given that the size of the sampled online media content differs in these units. There are also significant variations between LSGUs in the number of lists of candidates, number of first-ranked and second-ranked candidates, number of mayoral candidates, and candidates for national minority seats. All these constraints should be taken into account when considering the incidence of mentions in a broader context.

The Mostar City Council does not reserve seats for minorities, the Mostar Mayor is elected indirectly by the City Council, and the period of pre-election campaign in Mostar did not match the period in other LSGUs. For those reasons, we present Mostar results separately.

Out of the 42,107 texts for 41 LSGUs, 323 in the pre-election campaign mentioned election candidates, and only 21 articles mentioned female candidates. Online media often mentioned male candidates already in the title – this was never the case with female candidates.

TABLE I. RESULTS.

	<b>Incidence (men)</b>	<b>Incidence (women)</b>
Bihać	5.0	0.6
Bosanska Krupa	0.9	0.3
Bosanski Petrovac	0.1	0.0
Bužim	2.1	0.0
Cazin	0.9	0.2
Ključ	0.5	0.0
Velika Kladuša	3.7	0.0
Domaljevac - Šamac	1.8	0.0
Orašje	2.3	0.1
Gračanica	0.9	0.0
Kalesija	5.0	0.3
Tuzla	2.3	0.2
Doboj Istok	0.1	0.0
Visoko	8.9	1.9
Zenica	2.9	0.0
Goražde	2.5	0.0
Bugojno	7.0	1.3
Jajce	4.2	0.4
Kiseljak	0.6	0.1
Kreševo	0.1	0.0
Travnik	2.0	0.0
Jablanica	0.3	0.1
Prozor - Rama	1.5	0.1
Ravno	0.5	0.0
Stolac	0.3	0.0
Čitluk	10.5	1.7
Grude	0.9	0.0
Ljubuški	2.3	0.0
Neum	0.3	0.0
Posušje	3.8	0.2
Široki Brijeg	0.4	0.0
Centar Sarajevo	1.7	0.1
Novi Grad Sarajevo	0.1	0.1
Stari Grad Sarajevo	2.5	0.0
Vogošća	0.1	0.0
Drvar	0.1	0.2
Glamoč	0.0	0.0
Kupres	0.4	0.3
Livno	1.9	0.0

In the first instance, we explored the average number of mentions overall for men and women. In the next instance, we aggregated the number of mentions for:

- regular seats in local councils,
- mayoral candidates,
- independent candidates for regular seats in local councils or mayoral positions,
- candidates for national minorities, and
- City of Mostar.

The 1,111 candidates from 41 LSGUs (excluding Mostar), are mentioned, on average 1.4 times in the online content of the observed media during the pre-election campaign. The 666 men in the sample were mentioned 2.2 times on average, with some of them mentioned 90 times (one candidate in Kalesija), and 480 of them (72.1 percent) not being mentioned even once in the observed content. Most of the men included in the analysis are list leaders and only 57 of them were second ranked on the list.

The 445 women candidates (350 of them in the second position on the list) are mentioned on average 0.2 times in the observed contents. However, only 32 out of 445 (7.2 percent) women were mentioned at all in the online media content, and even that narrower group is, on average, mentioned only 2.8 times. Among women, the highest recorded incidence is 17 times (Visoko). As many as 93 percent of the women in the sample were never mentioned in the collected online media content. Table I summarizes the average number of mentions for all persons in the sample, classified by municipality and gender.

## V. DISCUSSION

Incumbent mayors and councillors, as well as persons holding important positions at higher levels of government are overrepresented in media content – they are outliers increasing the average number of mentions of candidates running within LSGUs. Among women candidates, these outliers were Amra Babić, the former Mayor of Visoko who was running for the same post in 2020, and Vlatka Martinović, the incumbent director of the FBiH Institute of Health Insurance and Reinsurance who competed for the Čitluk Municipal Council as second on the list. Martinović and Babić are,

however, only rare examples of women in prominent positions.

Most mayors, councillors, and directors of public companies and institutions are male in BiH, and their dominance affects the significantly higher online presence of male candidates than women in pre-election campaign content online. For example, the average number of mentions for men in Bugojno is significantly affected by long-time Bugojno Mayor Hasan Ajkunić. In Jajce, Edin Hozam, a Mayor over several terms is mentioned 27 times. Similar are cases of Mayors Sead Džafić in Kalesija (96 times), Šuhret Fazlić in Bihać (40 times), and Marin Radišić in Čitluk (46 times). Mirza Ganić (Visoko, 80 times) is the former Prime Minister of the Zenica-Doboj Canton, and Ante Begić (Posušje, 17 times) is the former Minister in the government of the West-Herzegovina Canton.

The number of online mentions for the candidates running for regular council seats differs by gender, especially within Canton Sarajevo, where male candidates are mentioned once and female candidates zero times in online content. In the Bosnia – Podrinje Canton, women candidates are not mentioned in any of the searched texts. In the Posavina Canton, where there were only a few candidate lists and low number of candidates in the sample, the gender differences are also noticeable.

Of the 136 mayoral candidates, seven are women and 129 men. Women were mentioned on average 3.3 times, men 8 times. The highest number of mentions related to the former female Mayor of Visoko, who ran as an independent candidate in the 2020 Local Elections. Online media presence is near zero for independent mayoral candidates if the former Mayor of Visoko Amra Babić is excluded.

The 40 candidates competing for the reserved seats for national minorities were mentioned in observed content far fewer times than all other studied categories on average. Viewed individually, the only minority candidate from the sample mentioned at all in online media content is Nedžad Jusić in Tuzla, who is a long-time member of the FBiH Council of National Minorities and already a minority councillor in Tuzla. Of the seven women minority candidates, neither one received space in the media content of their LSGUs and cantons.

In Mostar, the sample included 115 candidates (55 female and 60 male) - 68 of them

were list leaders in the 2020 Local Elections, i.e., first on the list (50 men, 18 women). In Mostar, online media from the Herzegovina Neretva Canton and nationally relevant web portals mentioned male candidates 0.7 times on average, women only 0.2 times.

## VI. CONCLUSION

The analysis of the 2020 Local Elections was carried out at the initiative of the FBiH Gender Centre, but its main findings could be applied to Bosnia and Herzegovina as a whole. We received the data on candidates from the CEC of Bosnia and Herzegovina, and supplemented it with data from the CEC website Izbori.ba where necessary. The research focused on the number of mentions of male and female candidates in the online media web portals reporting from or about candidates from a selected sample of LSGUs in FBiH. The intention was to document differences in the frequency of mentions between male and female candidates in online media. Online media content was collected primarily using software tools and combined with data on candidates from CEC.

Policies that regulate media coverage, as well as self-regulatory standards, should promote the proportional representation of women in pre-election content. The BiH Press Code for Press and Online Media should be amended to recommend proportional representation of female candidates in pre-election content. A more complex problem is the need to regulate the proportional representation of women in the pre-election content of the electronic media, which should be pursued in future amendments to the Election Law.

Media focus their pre-election content on male (and rare female) candidates who have already been prominent and present in the media, either as mayors and councillors or as directors in local, cantonal, entity, or state institutions or companies. Journalists' and editors' inertia in selecting interlocutors and sources also influences the electorate in Local Elections - people vote for continuity rather than change. This continuity in almost all LSGUs also means the dominance of men in political life.

For female candidates, online social media and communication platforms can be strategically harnessed and used to women's advantage, because even the political parties in BiH still do not exploit these communication potentials (Facebook is possibly an exception). A

minimum requirement for using such platforms is the candidate's media and information literacy or continuous support of a person or a team of online political campaigners. In ideal conditions, political parties would provide this infrastructure to female candidates, but parties currently seem uninterested in substantive gender equality and will rarely make such resources available to female candidates. To compensate, gender equality institutions and non-governmental organizations could finance or directly provide such support in a targeted manner to bring female candidates closer to younger voters.

## REFERENCES

- [1] Thaler, R. H., & Sunstein, C. R. (2010). Nudge: Improving Decisions about Health, Wealth, and Happiness. *Economics & Philosophy*, 369-376.
- [2] Sears, D. O. (1993). Symbolic Politics: A Socio-Psychological Theory. *Explorations in Political Psychology*, ed. by Shanto Iyengar and William J. McGuire, New York, USA: Duke University Press, 113-149.
- [3] Gorton, W. A. (2016). Manipulating citizens: How political campaigns' use of behavioral social science harms democracy. *New Political Science*, 38(1), 61-80.
- [4] Burkell, J., & Regan, P. M. (2019). Voter preferences, voter manipulation, voter analytics: policy options for less surveillance and more autonomy. *Internet Policy Review*, 8(4), 1-24.
- [5] Broström, G. (2022). *Event History Analysis with R*. Boca Raton: Chapman and Hall/CRC.
- [6] Ceja, E. G. (2021). *Behavior Analysis with Machine Learning Using R*. Boca Raton: Chapman and Hall/CRC.
- [7] Kennedy, R., & Waggoner, P. D. (2021). *Introduction to R for Social Scientists: A Tidy Programming Approach*. Boca Raton: Chapman and Hall/CRC .
- [8] Rizzo, M. L. (2008). *Statistical Computing with R*. Boca Raton: Chapman & Hall/CRC.
- [9] Ugarte, M., Militino, A., & Arnholt, A. (2015). *Probability and Statistics with R (2nd ed.)*. New York: Chapman and Hall/CRC.
- [10] Urdinez, F., & Cruz, A. (2020). *R for Political Data Science*. Boca Raton: Chapman and Hall/CRC.
- [11] Klüver, H. (2009). Measuring interest group influence using quantitative text analysis. *European Union Politics*, 10(4), 535-549.
- [12] Maindonald, J., & Braun., J. (2002). *Data Analysis and Graphics Using R*. Cambridge: Cambridge University Press.
- [13] Roberts, M. S. B. (2016). Navigating the local modes of big data: the case of topic models. In U. R. Alvarez (Ed.), *Computational Social Sciences* (pp. 51-97). New York: Cambridge Univ. Press.
- [14] Wilkerson, J., & Casas, A. (2017). Large-scale computerized text analysis in political science: Opportunities and challenges. *Annual Review of Political Science*, 20, 529-544.

- [15] Wickham, H. (2022). *forcats: Tools for Working with Categorical Variables (Factors)*. Available at: <https://forcats.tidyverse.org/>
- [16] Wickham, H. (2022). *stringr: Simple, Consistent Wrappers for Common String Operations*. Available at: <http://stringr.tidyverse.org>,
- [17] Wickham, H., & Girlich, M. (2022). *tidyr: Tidy Messy Data*. Available at: <https://tidyr.tidyverse.org>,
- [18] Wickham, H., François, R., Henry, L., & Müller, K. (2022). *dplyr: A Grammar of Data Manipulation*.
- [19] Asr, F. T., Mazraeh, M., Lopes, A., Gautam, V., Gonzales, J., Rao, P., & Taboada, M. (2021). The gender gap tracker: Using natural language processing to measure gender bias in media. *PLoS one*, 16(1), e0245533.
- [20] McDonald, M., Porter, R., & Treul, S. A. (2020). Running as a woman? Candidate presentation in the 2018 midterms. *Political Research Quarterly*, 73(4), 967-987.



# Improving Digital Competences of Persons with Disabilities as a Precondition for an Inclusive Digital Economy: Evidence from Serbia

Milena Lazić<sup>1</sup>, Valentina Vukmirović<sup>2</sup>

<sup>1,2</sup>Institute of Economic Sciences, Belgrade, Serbia

<sup>1</sup>milena.lazic@ien.bg.ac.rs, <sup>2</sup>valentina.vukmirovic@ien.bg.ac.rs

**Abstract**—In a digitally-driven world with a constant need for digital workers, policymakers and organizations are focusing on digital labor as an employment strategy. Digital labor is characterized by the production of value which results from the interaction with ICTs, such as digital entrepreneurship and digital platforms. Entrepreneurship in digital platforms offers flexible work arrangements in terms of timetable and workplace. This employment opportunity is especially beneficial for persons who face physical barriers in the workplace or have to adapt the pace of work to their needs, such as persons with disabilities (PWDs). In Serbia, PWDs face high and tenacious unemployment rates. They result from workplace discrimination, unperformed assessment of work-related functional abilities, unfavorable socioeconomic background, and lack of professional skills. Despite the fact that creators of labor market policies in Serbia have introduced initiatives which should help in developing digital professional skills among PWDs, they are still very few. Besides, these initiatives mostly offer basic digital competences trainings for PWDs, which are not sufficient for gaining employment in the digital labor market. This paper shows that there is a need to understand whether PWDs perceive digital self-employment through digital entrepreneurship and digital platforms as a viable solution for the unemployment issue they face. This information can help create new training initiatives that would put the knowledge acquired to practical use.

**Keywords** – persons with disabilities, inclusive digital economy, digital competences, digital entrepreneurship, digital labor platforms

## I. INTRODUCTION

With approximately 15% of the global population, PWDs represent the world's largest minority [1]. It is estimated that the total number of PWDs living in the EU amounts to 87 million [2]. On average, the share of PWDs in the total population across the EU countries accounts for 24%. Most PWDs in the EU are over 65 (48.5%), while only 17.9% belong to the working-age population group. Of the total number of working-aged PWDs, only 50% are employed (compared to 75% of persons without disabilities – PWDs). According to [3], in 2019, 68% of the EU population with disabilities would have been directly exposed to the risk of poverty without social benefits, allowances and/or pensions.

The number of PWDs in Serbia is estimated to be more than 700,000, of which only 13% are employed [4]. According to the latest available official statistics [5], economic activity is the highest among PWDs with vision (14.4%) and hearing impairment (11.2%) and the lowest among those unable to perform daily living activities/personal self-care (2.3%), and those facing problems in communication/understanding (4.7%). The largest proportion of employed PWDs are qualified workers at the third level (level 3) of the NQFS (46.3%), followed by PWDs at the fourth level (level 4) of the NQFS (20.4%) and semi-skilled workers at the second level (level 2) of NQFS (12.6%). PWDs with completed primary education have the lowest share in the total number of employed PWDs in Serbia (12.2%) [6]. Moreover, PWDs



in Serbia are paid less compared to their non-disabled counterparts, i.e. only 18% of PWDs, in opposite to 64% of PWDs, have monthly incomes larger than 330 EUR [7]. The brief overview of the key labor market indicators implies that PWDs in Serbia face high rates of inactivity and unemployment, which inevitably contributes to their social exclusion, discrimination and poverty (material deprivation).

In contrast to the traditional working arrangements, the internet-based business models provide almost equal opportunities for PWDs and PWDs to engage in the labor market, contributing in that way to their inclusive employment [8]. Moreover, some authors [9] indicated that PWDs tend to be more self-employed than PWDs. However, to be able to successfully perform their digital venture activities or respond to their distant employer requirements, PWDs must possess an adequate level of digital competences, skills and knowledge [10]. In that regard, digital competences, skills and knowledge have long been considered a basis for innovation, competitiveness, boosting jobs and economic growth [11]. Recent studies [12] also revealed the linkage between adopting advanced ICT solutions and risk mitigation. Moreover, advancing digital skills and competences was recognized as a precondition for European growth and development in the Digital Agenda for Europe [13].

The subject of this paper is the evaluation of interest in starting a digital entrepreneurial venture and the assessment of the current level of knowledge of freelance platforms of PWDs in Serbia. The paper aims to identify the room for further improvement of the digital competences of PWDs in Serbia as a precondition towards more inclusive employment through digital labor platforms. The paper's main contribution reflects the fact that the potential of digital entrepreneurship and platform work is insufficiently recognized as a means of reducing the long-term unemployment of PWDs in Serbia.

The paper consists of six parts. After the introductory remarks, the potential of digital platform work has been introduced. In the third, fourth and fifth parts research methodology, sample and research results have been presented, respectively. The last, sixth part, concludes the paper and provides recommendations for policymakers in Serbia.

## II. THE POTENTIAL OF DIGITAL PLATFORM WORK

Platform work is defined as matching the demand and supply of paid work through an online platform using the algorithm [14]. In this process, the client offers work, the individual provides it, while the platform manages the process. Work on online platforms is realized as mass work (crowdwork), which is paid work from remote locations, whereby the employer does not have to be registered in the country of the workers he hires [15]. Crowdwork is the work engagement of many people (crowd), mainly divided into microwork and online freelancing or macrowork [16]. The term microwork is used to describe the practice of mass work that involves breaking larger projects into smaller work tasks, i.e. microtasks, which are advertised on online labor platforms for which individuals apply and perform them for monetary compensation. Microtasks usually do not require advanced digital competencies, can be realized in a shorter period of time and can thereby be repetitive. On the contrary, macrotasks require more advanced digital competences and are usually assigned to individuals and possibly their collaborator(s). Microtasks are typically monitored by algorithms, while workers are mostly anonymous. Platforms such as Clickworker and Mechanical Turk are examples of micro labor platforms. Macrotasks are substantially more complex and take more time to be completed. Clients monitor the quality of macrowork tasks, and workers must make their profile pictures and names visible on their profiles [17].

According to the International Labor Organization, since 2010, the number of digital labor platforms has increased fivefold [18]. Accordingly, the number of digital workers is rising exponentially. In 2018, Serbia was ranked among the leading countries in Europe and the world by the ratio of digital workforce relative to the country's population versus the total workforce [16]. Also, based on the annual income growth of online freelancers, Serbia ranked in the top 10 countries in the world in 2019 [17]. Based on these data, it can be considered that engagement on digital labor platforms represents an accepted work practice in Serbia.

In order to perform tasks on digital labor platforms, individuals do not have to possess work experience. This is of particular importance

for the long-term unemployed. PWDs represent one of the categories among the less likely individuals to obtain employment. The low employment rates among PWDs are the result of workplace bias and discrimination, unperformed assessment of work-related functional abilities, unfavorable socioeconomic background, and low educational and skill levels. As PWDs do not have to reveal their disability status to online employers, it can be assumed that digital technology advances can offer fairer work opportunities for this traditionally excluded group in the labor market. Therefore, the authors of this paper aimed to investigate the attitude of persons with disabilities towards work on digital labor platforms and assess their knowledge about the principles and requirements of online platform work.

### III. METHODOLOGY

The research is a part of the project *Digital competences of persons with disabilities in Serbia and their involvement in online platform work – DigCompOSI*, financed by the Institute of Economic Sciences, Belgrade. In this paper, only selected sections will be presented using descriptive analysis. More information on the issue may be found in [8] and [19].

The sample consists of 245 Serbian residents, members of one of the twelve member organizations of the National organization of persons with disabilities of Serbia (NOOIS) and/or the Sports association of persons with disabilities Belgrade. The data were collected during March and April 2022 via a questionnaire in which the respondents assessed various statements on a four-point Likert scale: (1) I have no skills at all; (2) My skills are very poor; (3) I have some skills, but not sufficient to operate on my own; (4) I have sufficient skills to operate on my own.

The questionnaire consists of four parts. The first part includes the standard set of socioeconomic questions. The second part was designed to evaluate the general digital competences of the respondents. It was developed based on the methodology used in the Digital Competences Development System – Contents of the Self-Assessment Tool (2018), which is essentially grounded on DigComp 2.1 framework. Even though the DigComp 2.1 framework contains both questions for self-assessment and a practical task (real-life scenario), due to the specificity of the population observed, the questionnaire used in this research

contains only questions for self-assessment. The third part was designed to evaluate the digital entrepreneurial competences of the respondents, while the fourth part was designed to evaluate the respondents' knowledge of freelance platforms. The questions in the third and fourth parts were also based on DigComp 2.1 framework.

For the purpose of this paper, only selected questions included in the third and fourth parts of the questionnaire will be analyzed.

### IV. SAMPLE DISTRIBUTION

The gender distribution of the sample indicates an almost equal proportion of women (46.9%) and men (53.1%). More than 75.0% of the respondents are aged between 30 and 60. The largest share of the respondents is located in Vojvodina (38.4%) and Belgrade (29.0%). Distribution of the sample by education level reflects a higher proportion of PWDs graduated from high school (67.3%) and the faculty (20.0%). The dominant part of the respondents have difficulties with walking or climbing (71.4%).

### V. RESEARCH RESULTS

The research results indicate that 71.4% of the respondents had never started a digital entrepreneurial venture (Fig.1), while 68.6% declared they did not intend to engage in digital entrepreneurship (Fig.2).

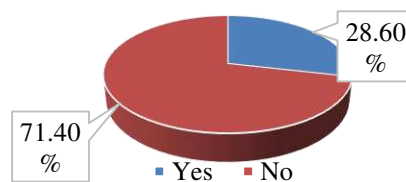

Figure 1. Distribution of respondents according to whether they have ever started a digital entrepreneurial venture.

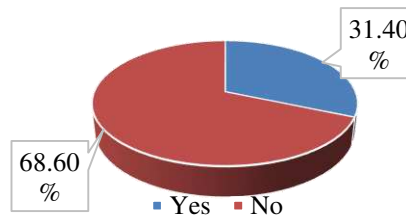

Figure 2. Distribution of respondents according to their intentions to engage in digital entrepreneurship.

Concerning the freelance platforms, only 38.8% of the respondents stated that they are familiar with what these platforms are and how they work (Fig.3).

Out of the total number of respondents familiar with the functioning of freelance platforms, 52.7% are able to recognize the various jobs available on these platforms. The remaining 47.3% possess certain or very modest abilities that are insufficient to independently perform the activity (Fig.4).

Concerning the ability to find a job on the freelance platform, 36.8% of the respondents perceive that they can independently find a job advertisement available on the freelance platform. Nevertheless, 63.2% of the respondents believe that they do not possess enough skills that would allow them to recognize an adequate opportunity for employment on freelance platforms (Fig.5).

Regarding the ability to apply for a job on the freelance platform, almost half of the respondents (47.1%) would not be able to independently apply for employment through freelance work platforms (Fig.6).

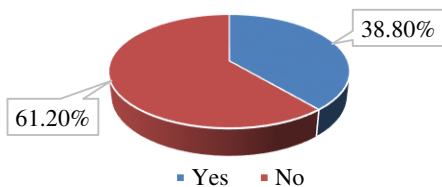

Figure 3. Distribution of respondents according to their knowledge of freelance platforms and their functionalities.

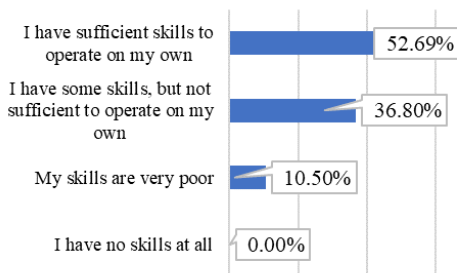

Figure 4. Distribution of respondents according to their ability to recognize the type of jobs they can apply for through freelance platforms.

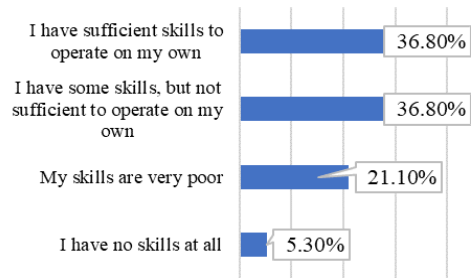

Figure 5. Distribution of respondents according to the possibility of finding a job on the freelance platform.

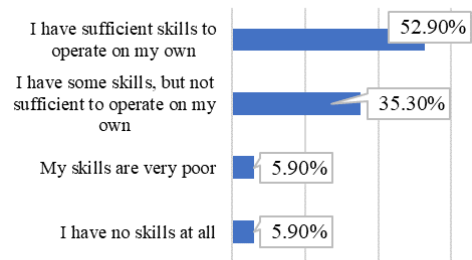

Figure 6. Distribution of respondents according to their ability to apply for a job on the freelance platform.

Concerning the ability to successfully implement the job found through the freelance work platform, more than half of the respondents believe that they do not possess an adequate level of ability to independently perform the task (Fig. 7).

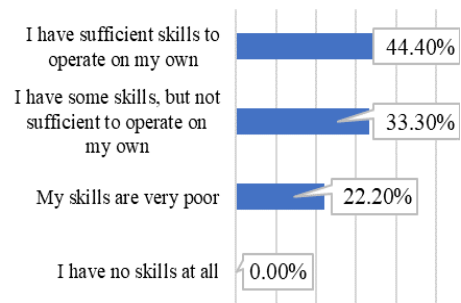

Figure 7. Distribution of respondents according to their ability to successfully implement the job they found on the freelance platform

## VI. CONCLUSION AND POLICY RECOMMENDATIONS

Although unfavorable, the respondents' low level of interest in engaging in digital entrepreneurship through online labor platforms could indicate that digital entrepreneurship is an insufficiently promoted and utilized strategy for improving the employment chances and economic position of PWDs in Serbia.

The results of this research lead to the conclusion that most respondents are not familiar with the functionalities and employment potential of freelance platforms - slightly less than 40.0% of respondents are aware of the freelance platform concept and their work mechanisms. Of that number, only about 50.0% of respondents are familiar with different types of jobs they can apply for on freelance platforms. The lower levels of competences are also noticeable in terms of the possibilities of searching and applying for a job on a freelance platform, as well as the ability to successfully perform work tasks obtained on a freelance platform.

The results of this research point to the need for introducing tailor-made retraining programs in advanced digital skills for work and digital entrepreneurial competencies, which could provide persons with disabilities with practical knowledge and empower them for self-employment through digital entrepreneurship on digital labor platforms. The existing programs are mostly created to provide training in the basic digital competences, and very few of them prepare the training participants for specific work positions offered in the labor market, such as web designer, IT administrator, or e-business specialist. Therefore, the skills provided in the retraining programs created by the labor institutions in Serbia should be aligned with the digital labor market needs. Accordingly, these programs should empower participants to search for employment on online labor platforms by introducing them to the platforms' work mechanisms and work terms and conditions. Additionally, the programs should provide trainings in soft skills, such as professional communication and negotiation, portfolio creation, and setting an adequate price for one's work.

## REFERENCES

- [1] UN (n.d.). *Factsheet on Persons with Disabilities*. Available at: <https://www.un.org/development/desa/disabilities/resources/factsheet-on-persons-with-disabilities.html>.
- [2] European Council (2022). *Infographic - Disability in the EU: facts and figures*. Available at: <https://www.consilium.europa.eu/en/infographics/disability-eu-facts-figures/>.
- [3] Eurostat (2021). *Disability statistics - poverty and income inequalities*. Available at: [https://ec.europa.eu/eurostat/statistics-explained/index.php?title=Disability\\_statistics\\_-\\_poverty\\_and\\_income\\_inequalities&olid=561947](https://ec.europa.eu/eurostat/statistics-explained/index.php?title=Disability_statistics_-_poverty_and_income_inequalities&olid=561947).
- [4] Mamula Nikolić, T., Nećak, M., & Blažanin, B. (2019). *Improving the employability of long-term unemployed persons with disabilities: Report from the survey of the position of persons with disabilities on the labor market in Belgrade, Kragujevac, Niš and Novi Sad*. Belgrade: Youth with disabilities forum.
- [5] Marković, M. M. (2016). *The 2011 Census of Population, Households and Dwellings in the Republic of Serbia – Persons with Disabilities in Serbia*. Belgrade: Statistical Office of the Republic of Serbia. Available at: <https://publikacije.stat.gov.rs/G2014/PdfE/G20144013.pdf>.
- [6] The Republic of Serbia, Ministry of Labour, Employment, Veteran and Social Affairs. (2020). *Strategy for the improvement of the position of persons with disabilities (2020-2024)*. Available at: <https://www.minrzs.gov.rs/sr/dokumenti/predlozi-i-na-crti/sektor-za-zastitu-osoba-sa-invaliditetom/strategije>
- [7] Kadjevich, Đ., Masliković, D., & Tomić, B. M. (2020). Familiarity with State Regulations regarding Access to Information for Persons with Disabilities in Serbia. *International Journal of Disability, Development and Education*.
- [8] Lazić, M., Vukmirović, V., Banović, J., Simović, V., & Paunović, M. (in press). Digital competences as a precondition for an inclusive digital economy - is there a gender gap among persons with disabilities in Serbia? *Journal of Women's Entrepreneurship and Education*.
- [9] Kitching, J. (2014). *Entrepreneurship and self-employment by people with disabilities*. OECD & LEED. Available at: <https://www.oecd.org/cfe/leed/background-report-people-disabilities.pdf>.
- [10] Radonić, M., Vukmirović, V., & Milosavljević, M. (2021). The Impact of Hybrid Workplace Models on Intangible Assets: The Case of an Emerging Country. *The Amfiteatru Economic Journal*, 23(58), 770-786.
- [11] European Institute for Gender Equality (n.d.). *Gender Equality Index 2020: Digitalisation and the future of work*. Available at: <https://eige.europa.eu/publications/gender-equality-index-2020-report/digital-skills-and-training>.
- [12] Rodríguez-Espíndola, O., Chowdhury, S., Kumar Dey, P., Albores, P., & Emrouznejad, A. (2022). Analysis of the adoption of emergent technologies for risk management in the era of digital manufacturing. *Technological Forecasting and Social Change*, 178.
- [13] European Commission (2010). *A Digital Agenda for Europe*. Available at: [http://ec.europa.eu/information\\_society/digital-agenda/index\\_en.htm](http://ec.europa.eu/information_society/digital-agenda/index_en.htm).
- [14] Eurofound (2022). *Platform work*. Available at: <https://www.eurofound.europa.eu/topic/platform-work>.

- [15] Anđelković, B., Šapić, J., & Skočajić, M. (2019). *Gig ekonomija u Srbiji: ko su digitalni radnici i radnice iz Srbije i zašto rade na globalnim platformama?* Centar za istraživanje javnih politika.
- [16] Margaryan, A. (2019). Workplace learning in crowdwork: Comparing microworkers' and online freelancers' practices. *Journal of Workplace Learning*, 31(4), 250-273.
- [17] Schmidt, F. A. (2017). *Digital Labour Markets in the Platform Economy Mapping the Political Challenges of Crowd Work and Gig Work*. Bonn: Friedrich-Ebert-Stiftung, Division for Economic and Social Policy.
- [18] International Labour Organization. (2021). *Can digital labour platforms create fair competition and decent jobs?* Available at: <https://www.ilo.org/infostories/en-GB/Campaigns/WESO/World-Employment-Social-Outlook-2021#introduction>.
- [19] Lazić, M., Vukmirović, V., Banović, J., & Simović, V. (unpublished). *Digital competences of persons with disabilities in Serbia and their involvement in online platform work – DigCompOSI*. Belgrade: Institute of Economic Sciences.

# Comparative Analysis of Human Development at the Global Level

Suzana Stojković<sup>1</sup>, Milica Stanković<sup>2</sup>, Tiana Anđelković<sup>3</sup>

<sup>1,2,3</sup>The Academy of Applied Technical and Preschool Studies – Vranje department, Vranje, Serbia

<sup>1</sup>suzana.stojanovic@akademijanis.edu.rs, <sup>2</sup>milica.stankovic@akademijanis.edu.rs,

<sup>3</sup>tiana.andjelkovic-vr@akademijanis.edu.rs

**Abstract**—Growth and development is an area of great importance and attention in economic science. Human resources are a factor without which modern business cannot be imagined. Human capital, i.e. employees, are drivers of the economic growth of the every country national economy, and therefore it is necessary to invest in the education system, i.e. invest in the knowledge of employees in order to achieve economic growth and development. The standard of living has a direct impact on human development, and it depends on long-term economic growth. The aim of the work is to describe the concept of human development, the importance of human resources in modern business conditions and the trends of human development at the global level.

**Keywords** - human development index, education, human development

## I. INTRODUCTION

We all live in a world of change today. The COVID-19 pandemic has led to upheavals in human development throughout the world and continues to unpredictably create new changes and upheavals. War, in addition to the pandemic, contributes to changes in the development of human society and creates new problems for humanity. There has been a changing geopolitical order and a strained multilateral system.

Record temperatures and storms, highly variable human-caused weather conditions cause every alarm bell to stop working and notify us of all changes and dangers. Acute crises give way to chronic, layered, interconnected uncertainties on a global scale, creating a picture of uncertain times. Uncertainty and changes are the

characteristics of modern human life and the best way to overcome all problems is to double human development.

There is a widening gap between developed and developing countries, rich countries are getting richer and developing countries are struggling to close the gap that already exists. Intellectual capital is the basis for further development of both developed and developing countries. Developed countries, in addition to intellectual capital, constantly gain their position with the help of material capital. Developing countries continue to produce raw materials for developed countries leading to the creation of the extremely rich and the poor.

Investing in the education and knowledge of employees in modern changing business conditions, when changes need to be predicted, is a necessary condition for the development of all developing countries, and it is the economy based on knowledge and innovation that can reduce the difference that exists between developed and developing countries. It is necessary to constantly invest in the knowledge of employees and in their retraining and retraining in order to keep up with changes and to achieve growth and development. The aim of the work is to describe the concept of human development, the importance of human resources in modern business conditions and the trends of human development at the global level.

## II. THE CONCEPT OF HUMAN DEVELOPMENT

The level of economic development of each country affects the quality of its inhabitants life.

For people, in addition to the standard of living and the ability to meet their needs, education, security, freedom of speech are also very important... The Human Development Index (HDI) is one of the most important indicators of the quality of life and has been used by the United Nations in its assessments since 1990. The human development index is influenced by the well-being, choice and perspectives of the population. Human development is measured with the help of the aggregate HDI measure, and it consists of three parameters: healthy life and living environment, the possibility of acquiring knowledge and education, and the level of the standard of living. Therefore, in addition to determining the current economic position of the national economy, the human development index also monitors the quality of human life through health care and education. If we look back at access to knowledge and education, we can see that there are two indicators, namely the average and expected number of years of schooling. The movement of the gross social product shows the possibility for unhindered satisfaction of needs and the possibility of achieving a better standard of living [1].

In step with the technical-technological revolution and economic growth, it is necessary to transform the concept of human development and define a standard that determines the level of human development in order to assess the level of human development in a certain country. The challenges of modern society, which are a consequence of the COVID-19 pandemic and war, are great and have led to changes in the development of society. It is necessary to create better conditions for life and work in order for the human development index to be better and for it to continue the upward trajectory it was on before the crises facing human society. Investing in human capital, through the process of education, training and retraining, is the way to successfully overcome every new crisis.

The key elements of the human development concept are:

- Humanity - the goal of development represents a greater degree and improvement of the human life quality;
- Efficiency - optimal use of human resources, through investment in education, health and skills of people, with efficient allocation of resources;

- Empowerment - the concept of human development implies an active role and great involvement of people in creating development;
- Equality - implies equal access of all people to opportunities and equal distribution of income and property;
- Sustainability - all resources should be used so that people take care of future generations;
- Trust and solidarity - we need to develop the value of society and raise awareness of the understanding of vulnerable groups;
- Comprehensiveness - the concept of human development includes all dimensions of human development: economic, health, educational, political, social and cultural [2].

One of the basic questions in economic theory and practice is whether countries should invest more in education in order to ensure economic growth, and there are opinions that investments in education accelerate economic growth [3].

### III. EDUCATION AS A FUNCTION OF HUMAN DEVELOPMENT

According to Schulz, education is a driver of development not only through raising the quality of the human factor, but it is also a strong factor in the quality of other factors of production. Equipment and devices would not have been developed at this level and would not have been further developed if they had not been perfected by highly educated workers. Human capital and technology are linked and together influence economic growth and development. The crisis facing the whole world can be overcome with the help of innovation and new technologies. Innovations and new technologies lead to a new type of development, i.e. lead to green business and digital society. Green business and digital society are topics that are very current in research because we all have to think about future generations and ensure their survival [4].

The Republic of Serbia adopted the Education Development Strategy in the Republic of Serbia and it is aimed at providing the foundation for the development of every resident of the country, society and the development of the country as a whole. The strategy defines the

goals of long-term development of education and they include:

- improving the quality of the education process and its outcome to the maximum possible level based on the best educational practices;
- improvement of education at all educational levels - from preschool education to lifelong learning;
- improvement and maintenance of education that is fully or partially financed from public sources;
- greater efficiency in the use of all educational resources and completion of education within the period provided for [5].

Investing in human capital, that is, in the education of the population, is of great importance for the efficient and effective use of economic opportunities. In labor markets, priority is given to cognitive skills (solving complex problems), sociobehavioral skills (teamwork) and combined skills based on logical thinking. In order to build all the aforementioned skills, it is important to invest in human capital, in the development and improvement of employees' knowledge, as well as in lifelong learning. It is necessary to acquire and improve knowledge constantly in order for the economy to be competitive in the market where changes are the only constant. Human capital can create great advantages for all who possess it and who nurture it through continuous education, and for this reason developed societies pay great attention to education. Educated people and developed human capital result in the development of new ideas and technologies, that is, innovations that directly affect economic growth and development.

“Education contributes to the generation of ideas and the spread of technology. The rates of technological change and the increase in productivity are directly related to the level of human capital, hence the great impact of education on economic growth” [6].

#### IV. HUMAN DEVELOPMENT INDEX

The complex indicator, which is most widely used throughout the world and which is used for international comparisons and evaluations of the achieved development of each country, is the Human Development Index (HDI). The Human

Development Index was developed by the United Nations and was first used in the 1990 in Human Development Report [7]. Along with the development of human society, there was a need for a common measure of economic and social development and a comparison of the human development level of all countries in the world. As a result of the search for such a measure, the human development index was created, which gives the overall picture of the country development in a comprehensive and different way compared to all other indicators. For this reason, this indicator is most often used throughout the world.

The United Nations Development Program publishes an independent editorial publication, the Human Development Report, every year. The United Nations for Development published the first report in 1990 under the title “People are the real wealth of nations” and thus introduced a different and new approach to the development of human society [8].

The Human Development Index is a combination of three different indicators that represent the opportunities that people expect to achieve, and are available in almost all international statistical yearbooks (international data provided by the UN Population Division, the UN Institute for Education, Science and Culture (UNESCO), and World Bank), namely:

- general quality of life,
- education, and
- standard of living, i.e. economic well-being of people.

By reducing these three indicators to one common measure, all countries of the world are classified into one of four categories, which indicate the level of human development achieved:

- $0.000 < \text{HDI} < 0.550$  - low level of human development;
- $0.550 < \text{HDI} < 0.699$  - medium level of human development;
- $0.700 < \text{HDI} < 0.799$  - high level of human development;
- $0.800 < \text{HDI} < 1.0$  – very high level of human development.

The human development index is calculated in order to rank world economies according to



the level of the human development index. When comparing the human development index with the ranking based on the gross domestic product per capita, three situations are possible:

- if the HDI rank is close to the rank of gross domestic product per capita, it means that there is harmony between existing resources and development results;
- if the HDI rank is higher than the rank of the gross domestic product per capita, it means that the development policy is conducted in the function of the entire population;
- if the HDI rank is lower than the rank of the gross domestic product per capita, it means that in the given area the development policy is not in the function of the entire population.

The Human Development Index charts human progress and highlights large differences in well-being and life chances between countries by age. The value of the specified index for each of the countries represents the range between the maximum value and the value that country had in a given year, which gives an opportunity for comparison with other countries and their results. Based on the value of the HDI index, each of the countries can see what their shortcomings are and, based on the identified shortcomings, find a way to reduce them and get closer to the maximum value. Regardless of all the advantages of the HDI index, it will never perfectly capture human development in its full sense [9].

Fig.1 shows the values of the human development index at the global level by year starting from the first report in 1990 and ending in 2021. It can be seen in the figure that the value of the human development index at the global level has been declining in the last two years due to the consequences of the COVID-19 pandemic and war. The COVID-19 pandemic and the ongoing war have brought many changes to people’s daily lives. Food and water shortages, as well as price changes, are problems that all people face. Due to the action of the aforementioned changes, the constant growth of the value of the human development index was interrupted.

The difference between the planned and realized movement of the human development index curve is clearly visible. The value of the human development index was projected to increase, but the value of the same has declined and continues to decline because the problems faced by human society in recent years have not been eliminated. It is necessary to improve people’s quality of life so that the value of the human development index continues to move upward.

Fig.2 shows the share of countries by groups of human development index values. There are three groups of human development index values and all the countries of the world occupy a value in one of the groups, namely:

- a group of countries with a low and medium HDI index,
- countries with a high HDI index, and
- countries with a very high HDI index.

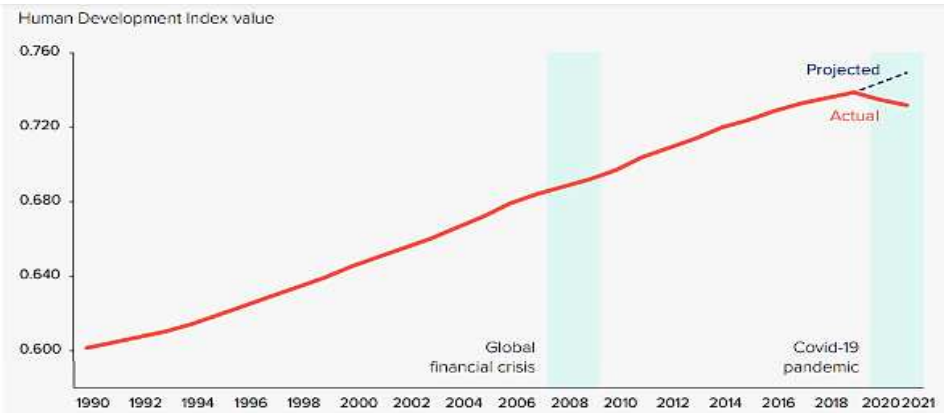

Figure 1. The value of the human development index at the global level by year [10].

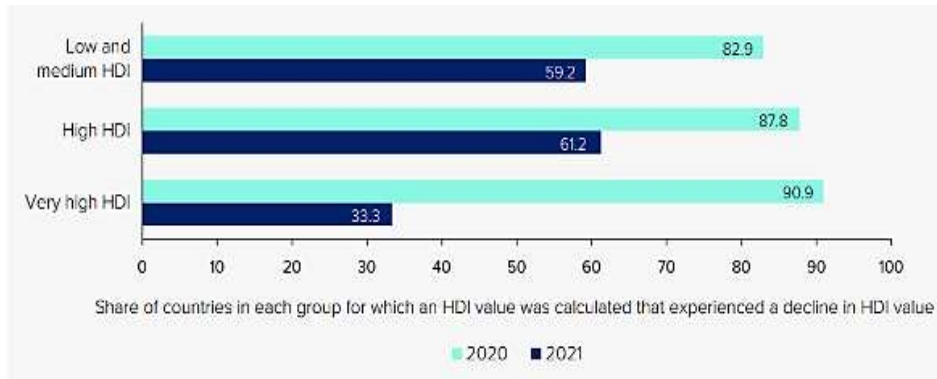

Figure 2. The share of countries in each group of human development index values for which the HDI value was calculated and which experienced a decline in the HDI value [10].

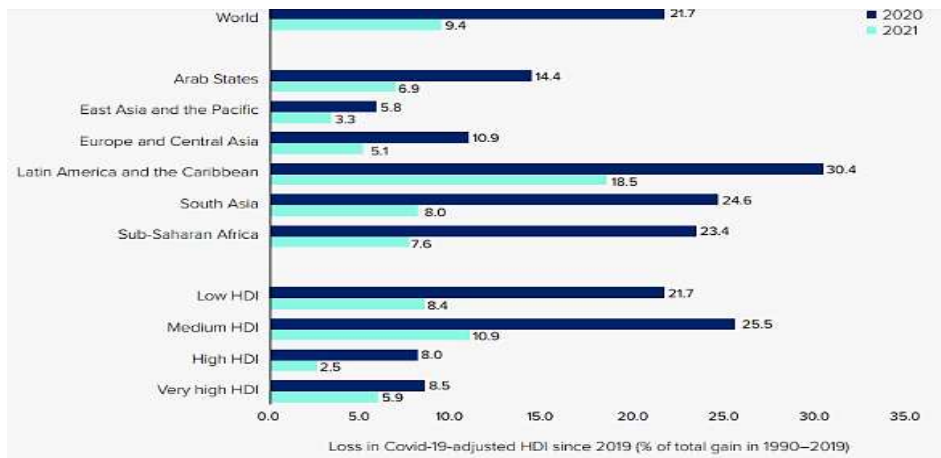

Figure 3. Widespread but uneven decline in human development index (HDI) values after the COVID-19 pandemic: regional and group aggregates [10].

In all countries of the world for which the HDI value was calculated, a drop in the HDI value was noted, regardless of which group they belong to. Most of the countries with a very high HDI did not suffer a significant decline in HDI in 2021, but, in contrast, most of the countries with a low and medium level of HDI suffered a large decline. Developed countries and countries with a high HDI index have developed methods to prevent and overcome the problems they face and invest continuously in innovation.

Fig.3 shows the decline in the value of the human development index in 2021 compared to 2020. The decline in value is evident and widespread, but is uneven when looking at different levels of HDI values. The uneven decline in the value of the human development index after the COVID-19 pandemic is shown. The COVID-19 pandemic is one of the main reasons for the drop in the HDI value because the

world has undergone great changes, starting with the closure of countries and the impossibility of travel, through shortages of basic foodstuffs, a large number of infected people... All this leads to consequences of a large scale when looking at the quality of human life and the economy of every country in the world.

Table I shows the top 10 countries with the highest value of the human development index for 2021. The country with the highest value of the development index is Switzerland, whose HDI value is 0.962, followed by Norway, whose HDI value is 0.961, and which was in first place in 2020. In third place is Iceland, and the value of the human development index is 0.959. In the report for 2020, Iceland was in second place. All countries, which belong to one of the first places when we look at the human development index, have a long life expectancy, highly developed education and a large GNI per capita.

TABLE I. TOP 10 COUNTRIES WITH THE HIGHEST HDI VALUE [10].

HDI rank	Country	Human Development Index (HDI)	Life expectancy at birth	Expected years of schooling	Mean years of schooling	Gross national income (GNI) per capita	HDI rank
		Value 2021	(years) 2021	(years) 2021	(years) 2021	(2017 PPP \$) 2021	2020
1	Switzerland	0.962	84.0	16.5	13.9	66.933	3
2	Norway	0.961	83.2	18.2	13.0	64.660	1
3	Iceland	0.959	82.7	19.2	13.8	55.782	2
4	Hong Kong, China (SAR)	0.952	85.5	17.3	12.2	62.607	4
5	Australia	0.951	84.5	21.1	12.7	49.238	5
6	Denmark	0.948	81.4	18.7	13.0	60.365	5
7	Sweden	0.947	83.0	19.4	12.6	54.489	9
8	Ireland	0.945	82.0	18.9	11.6	76.169	8
9	Germany	0.942	80.6	17.0	14.1	54.534	7
10	Netherlands	0.941	81.7	18.7	12.6	55.979	10

Each of the top 10 countries with the highest HDI value also occupied one of the top 10 places in the previous report for 2020.

Based on the data from the table, it can be seen that each of the countries invests improving people's quality of life and living standards and invests significant funds in education and retraining of the population, which results in a longer life expectancy of the population and a higher degree of satisfaction for all people. The longest life expectancy was recorded in Hong Kong at 85.5 years.

Table II shows the human development index of Serbia among other countries. The Republic of Serbia is on the list of countries with a very high value of the human development index and is in 63rd place together with Georgia and Mauritius. The HDI value for Serbia is 0.802. Life expectancy in our country is 74.2 years, which is less than the leading countries. In the previous year, the Republic of Serbia was in 62<sup>nd</sup> place. This leads us to the conclusion that changes are necessary in our country in order to find a better position and to improve the quality of life of the population of our country. The country that ranks last when we look at countries with a very high

TABLE II. HUMAN DEVELOPMENT INDEX OF SERBIA AMONG OTHER COUNTRIES [10].

HDI rank	Country	Human Development Index (HDI)	Life expectancy at birth	Expected years of schooling	Mean years of schooling	Gross national income (GNI) per capita	HDI rank
		Value 2021	(years) 2021	(years) 2021	(years) 2021	(2017 PPP \$) 2021	2020
60	Belarus	0.808	72.4	15.2	12.1	18.849	60
61	Panama	0.805	76.2	13.1	10.5	26.957	67
62	Malaysia	0.803	74.9	13.3	10.6	26.658	61
63	Georgia	0.802	71.7	15.6	12.8	14.664	64
63	Mauritius	0.802	73.6	15.2	10.4	22.025	62
63	Serbia	0.802	74.2	14.4	11.4	19.123	62
66	Thailand	0.800	78.7	15.9	8.7	17.030	64

HDI value is Thailand and the HDI value is 0.800.

The basic premise of the further human development of Serbia lies in the removal of obstacles and all problems, first of all, by reducing poverty, solving a number of environmental issues, it is necessary to modernize the health infrastructure, reduce the percentage of households that are not connected to water supply and sewerage, improve educational conditions and make the illiterate part of the population literate as well as a further increase in the IT literacy rate. It is very important that Serbia reaches a higher level of equality between the sexes. In addition, the growth of the gross domestic product and the reduction of unemployment are needed. It is necessary to continue with the construction of adequate information systems in all segments of human development in Serbia, to determine the factual situation and the causes of negative trends. All of this would significantly contribute to the establishment of a healthy base for human development in Serbia in the coming period.

#### V. THE IMPACT OF HUMAN DEVELOPMENT AT THE GLOBAL LEVEL ON RISK MANAGEMENT AND INNOVATION

Human development is a topic that is the focus of a large number of researchers. All changes faced by human society should not be seen as obstacles, but as new opportunities. New technologies have enabled rapid progress in human development, for example, in healthcare, antibiotics and vaccines have significantly extended life expectancy [12].

Global climate change is a serious threat to people and natural ecosystems. They have a significant impact on the daily life of people, as well as on the environment, business and economic development. [13]. In China, rapid industrialization and economic expansion, together with excessive use of energy and natural resources, have resulted in significant environmental degradation [14,15]. The ongoing COVID-19 pandemic is having a significant impact on global health, as well as on social, economic and political institutions [16]. Resources, which are limited and dwindling, require ever stronger efforts by people to create and implement new ideas with the help of innovative thinking. Innovations in health, pharmaceuticals, energy, artificial intelligence and quantum computing [17] are critical to

overcoming obstacles such as the COVID-19 pandemic.

Innovation is essential for strengthening competitiveness, and modern business conditions and changes in the market, such as the emergence of e-commerce, lead to the need for companies to be innovative in order to survive and develop in the market. [18] Many hopes today are placed in positive transformational changes, which rely on technological innovation. Technological change affects human development in a number of ways - through people's broader ability to do more things and affects the social context and everyday activities of people. Innovation drives growth and helps solve societal challenges, [19] contributing to mitigating climate change, promoting sustainable development and promoting social cohesion. It represents a broad process of transformation in which people's initiative and creativity interact with social, economic and political choices.

In the past two years, a number of authors have addressed innovation as a state-of-the-art survival strategy in crisis situations like the COVID-19 pandemic [20]. In the event of a pandemic, organizations must adapt to new technology and all the changes they face. Human development, fueled by technological revolutions, economic crises and new regulations, creates new opportunities for the production of materials, structures, processes and capacities. Innovative technologies improve business analysis and forecasting, new product creation, order processing, logistics, automation, quality control, and marketing [21]. Business Model Innovation (BMI) is one way to overcome all the obstacles faced by small and medium enterprises [22,23]. Open innovation is one way to minimize the impact of the COVID-19 pandemic on education, the economy and people's daily activities, which affects the quality of life [24,25].

The role of education and knowledge in the modern world is very important and leads to the development of people's creative potential and the functioning of society. The increase in the importance of scientific and technological innovations and the application of new information and communication technologies in everyday life provides numerous opportunities. The aspiration for the fastest possible human development is in correspondence with the accelerated adaptation to the requirements of

technical and technological progress and the needs of the labor market. In addition to improving creativity, entrepreneurship and innovation, education contributes to job creation and economic growth, which leads to human development. Education is one of the greatest values of society because it helps us understand the world in which we live.

## VI. CONCLUSION

Where we go next depends on all of us. The entire human society and our planet go through and have gone through periods of change and instability. It is necessary to find a way to solve all problems as soon as possible and to continue the development of human society. The key characteristic of this era is the role of people with their knowledge and therefore it is necessary to invest in education and the level of social wealth because it represents a way to overcome all obstacles in order to build a better future. Without human capital, there is no economic growth and development, and knowledge-based economies consistently achieve better results than others. Only highly educated human capital is the one that is economically desirable and of high quality. All highly developed economies of the world have noticed that education is a condition for success and a greater value of human capital, and they are the carriers of technical and technological development. As long as there is a disproportionate educational structure of the population in the world, the gap between developed and developing countries will be pronounced because education is the engine of economic growth.

## REFERENCES

- [1] UNDP (2016).
- [2] UNDP Serbia (2011).
- [3] Aghion, P., Boustan, L., Hoxby, C., & Vandenbussche, J. (2009). The Causal Impact of Education on Economic Growth: Evidence from U.S. In D. Romer & J. Wolfers, (Eds.), *Brookings Papers on Economic Activity*.
- [4] Bujišić, B. (2013). *Obrazovanje, ljudski kapital, razvoj*. Institut društvenih nauka Beograd.
- [5] Ministarstva prosvete, nauke i tehnološkog razvoja. (n.d.). *Akциони plan za sprovođenje strategije razvoja obrazovanja u Srbiji do 2020*.
- [6] Šuković, D. (2013). *Ljudski kapital, ekonomski rast i nejednakost*. Institut društvenih nauka Beograd.
- [7] UNDP. (1990). *Human Development Report*.
- [8] Ferjan, I. (2014). Holističko merenje životnog nivoa: Indeks humanog razvoja. *Economics*, (2), 51-68.
- [9] Kovačević, M. (2011). *Review of HDI Critiques and Potential Improvements*. UNDP.
- [10] UNDP. (2022). *Human development report 2021/2022: Uncertain times, unsettled lives: Shaping our future in a transforming world*.
- [11] Vlada Republike Srbije. (n.d.). *Srbija i Agenda 2030*.
- [12] UNDP. (2020). *Human Development Report 2020: The Next Frontier: Human Development and the Anthropocene*. New York.
- [13] Lee, C. C., & Lee, C. C. (2022). How does green finance affect green total factor productivity? Evidence from China. *Energy Economics*, 107, 105863.
- [14] Liu, Z., et al. (2015). Climate policy: steps to China's carbon peak. *Nature*, 522, 279-281.
- [15] Naseem, S., Mohsin, M., Zia-UR-Rehman, M., Baig, S. A., & Sarfraz, M. (2022). The influence of energy consumption and economic growth on environmental degradation in BRICS countries: an application of the ARDL model and decoupling index. *Environmental Science and Pollution Research*, 29(9), 13042-13055.
- [16] Meyer, N., Niemand, T., Davila, A., & Kraus, S. (2022). *Biting the bullet: When self-efficacy mediates the stressful effects of COVID-19 beliefs*. *PloS one*, 17(January), 1-16.
- [17] Soumitra, D., Bruno, L., Rivera Leon, L., & Wunsch-Vincent, S. (2021). *Global Innovation Index 2021: Tracking Innovation through the COVID-19 Crisis*. World Intellectual Property Organization.
- [18] Lafkihi, M., Pan, S., & Ballot, E. (2019). Freight transportation service procurement: a literature review and future research opportunities in omnichannel e-commerce. *Transportation Research Part E: Logistics and Transportation Review*, 125, 348-365.
- [19] OECD. (2019). *The OECD innovation strategy, getting a head start on tomorrow*. Paris: OECD Publishing.
- [20] Sharma, R., Lopes de Sousa Jabbour, A. B., Jain, V., & Shishodia, A. (2022). The role of digital technologies to unleash a green recovery: Pathways and pitfalls to achieve the European Green Deal. *Journal of Enterprise Information Management*, 35(1), 266-294.
- [21] Jemala, M. (2021). Long-term research on technology innovation in the form of new technology patents. *International Journal of Innovation Studies*, 5(4), 148-160.
- [22] Adam, N. A., & Alarifi, G. (2021). Innovation practices for survival of small and medium enterprises (SMEs) in the COVID-19 times: The role of external support. *Journal of Innovation and Entrepreneurship*, 10(1).
- [23] Clauss, T., Breier, M., Kraus, S., Durst, S., & Mahto, R. V. (2022). Temporary business model innovation – SMEs' innovation response to the COVID-19 crisis. *R and D Management*, 52(2), 294-312.
- [24] Almeida, F. (2021). Open Data's Role in Social Innovation Initiatives to Fight COVID-19. *Central European Management Journal*, 29(3), 2-19.
- [25] Surya, B., et al. (2021). Economic growth, increasing productivity of smes, and open innovation. *Journal of Open Innovation: Technology, Market, and Complexity*, 7(1), 1-37

# School Culture as a Predictor of School Identity

Dinko Jukić<sup>1</sup>

<sup>1</sup>Trade and Commercial School “Davor Milas”, Osijek, Croatia

<sup>1</sup>dinkojukic.phd@gmail.com

**Abstract**—The paper research and analyse school culture and school identity. It is based on Balmer’s methodology of the AC<sup>2</sup>ID Test model, according to which different identities of the school are presented. The study uses a hermeneutic perspective and content analysis. A research question is asked, what constitutes school identity and tries to connect the importance of school culture and school identity. It is based on the premise that school culture is a predictor of school identity and that a positive image can be built through building the school’s reputation, teacher satisfaction and service quality. Teachers were observed from two aspects: educational and economic. The educational aspect emphasizes the importance of teachers and their identity, while the economic aspect observes teachers as carriers of school promotion and service providers. It is concluded that the construct of school culture represents a crucial element of identity building and that school identities important for school management and marketing can be predicted through school culture.

**Keywords** – identity, image, teacher, school culture, service

## I. INTRODUCTION

A school is a living organism that depends on teachers, students, and the environment. As a non-profit organization and a socially responsible institution, it is a specific educational institution. The specificity of the school stems from its existence as an educational and cultural institution formed by the curriculum, teachers, geographical area, and society.

Teachers are the fundamental bearers of school and education [1]. They are simultaneously its promoters and service providers [2]. The issue of curriculum and education is important for every government, so

the very concept of schooling is viewed from political, economic, sociological, and pedagogical aspects. Schools, regardless of whether they are private or state, reflect two key characteristics of society: the formation of students and the formation of national identity. High-quality universities and schools symbolize cities, regions and countries, and high-quality teachers represent faculties, schools [3], their fields and departments.

The topic of this paper is school culture (SC) and its influence on the creation of the school’s reputation, that is, the analysis of school identity (SI). Since schools in Europe are mostly non-profit institutions, the issue of school identity and image is not only a matter of school management (SM) [1,2], but also a question of long-term survival in the field of education.

This especially applies to high schools and colleges, unlike elementary schools, which are regionally oriented and have no competition. Therefore, the paper tries to answer the question in which context SC is a predictor of identity. In this sense, the question of how to build a school image was analysed.

## II. METHODOLOGY

The work uses qualitative methodology [4,5], i.e., interpretive-constructivist paradigm [5]. It starts from a hermeneutic perspective and content analysis of relevant sources on corporate identity [6,7]. The SI analysis methodology was observed according to Balmer’s AC<sup>2</sup>ID Test model to show different identities. According to Keller [8], the brand image was analysed.

The aim of this study is the analysis of visible and invisible SC in the context of SI construction. It assumes that SC is a predictor of school

identity, i.e., that elements of brand identity can be diagnosed and analysed through SC. Also, SC was analysed in the context of building the school's identity and image, and emphasis was placed on the importance of teachers.

The limitation of the work is the fact that it is based on qualitative research. The paper presents theoretical models that have not been empirically evaluated. In further research, it is possible to explore the perception of SC through three different forms of secondary schools (gymnasiums, art, and vocational schools) and compare their common features. Also, different forms of school identity can be researched and compared with employee satisfaction.

### III. SCHOOL CULTURE

School culture (SC) is a complex concept [9,10]. Every educational organization like school, college and university has its own specificity. The personality of the school as an organization, its way of working, the behaviour of employees and their attitudes make up the SC construct. School culture can be strongly oriented towards employees, organization, students, service, image, and society. This way of working, behaviour and life of the organization forms the base of SC.

Each school has its own type of SC, which depends on the school's strategy, goals, and leadership. There are no two identical schools, just as there are no two SC's that are the same. SC consists of the dominant culture and different subcultures (students, teachers, pedagogues, parents, stakeholders). This relationship between SC, society's culture and teacher's identity is woven into school management (SM).

SC is a stable phenomenon that reflects the mission of the school (see Table I). The common values of an organization, i.e., the feeling of belonging to the company, is most often called organizational culture. Organizational cultures differ from each other just as SCs differ from each other according to teachers, type of school, area of affiliation, way of leadership and management methods.

TABLE I. SCHOOL MISSIONS BY TYPE OF EDUCATION

Gymnasiums	Vocational school	Art school
General culture	Labour market	Art
Learning	Work	Creativity
Study	Specialization	Exhibitions

As can be seen from Table I, school missions reveal the school's cultural models and their SC. In this way, school culture provides SI models and employee action. It is about the school's corporate image [6] and reputation [7]. Analysing the types of secondary schools and their characteristics, it is obvious that gymnasiums have a different SC than vocational and art schools. The reason for this stems from the specificity of the gymnasium goals and missions, which focus on lifelong learning, general culture and preparing students for further education.

Unlike gymnasiums, art schools encourage creativity (music, painting, sculpture, dance), and their goal is nurturing art and opening an exhibition. Finally, vocational schools are focused on the labour market, and they conduct specialization to train students for work (see Table I).

In this sense, SC depends on numerous factors such as ownership (private and public schools), teachers, school type and school size. Some authors consider the SC concept too general [11] because it connects concepts from anthropology and sociology [12,13] such as myth, symbol, ethos, and habitus [13,14]. School culture can most simply be described as the shared beliefs and values of the school. Strong SC shapes employee behaviour. School culture consists of frameworks, products, expressions, and activities [15].

SC depends on the way of managing the school [1,3,11], motivating employees and building and maintaining the image [2]. Also, it is important to emphasize that SM often includes general management [9,11] because it is not in accordance with the educational values of the school, and thus the school is viewed in the context of the market, not education. This is also the biggest criticism of SM because it relies on management, not school leadership.

#### A. School management and school climate

Despite the criticism of SM as focusing on the service itself, employees and hierarchy, the fact is that management in education is necessary [10,13]. From the economic aspect, the school as an educational institution that provides systematic knowledge in certain areas (depending on the type of school) has no competition. The main goal of the school is education, and, in this sense, schools are necessary for the development of society.

However, the school represents a social, cultural, and educational community of teachers, students, parents, and all others who contribute to the realization of educational goals. (see Table II). In this sense, the school represents the most organized form of all educational factors. Its autonomy refers to teaching and adapting the curriculum for its programs [10,16].

The social roles of schools refer to the provision of professional qualifications, nurturing tradition, and legal regulation of education. The communicative role of the school includes the interaction of teachers and students, collaborative relationship, and community with other stakeholders [17]. The pedagogical role includes upbringing and an educational dimension. From the above, it can be concluded that SC depends on the role and type of school.

School climate, in contrast to SC, refers to the perception of employees, i.e., to the school “atmosphere”. Therefore, school climate represents the perception of employees who work in the same environment and their common views, beliefs and value system affects the behaviour of all employees. This means that the school climate refers to teachers, describes their behaviour, is based on the teachers’ routine actions, and affects their attitudes.

Since there is a connection between organizational climate [18,19], i.e., school climate and other organizational variables, such as the connection between job satisfaction, work performance and SM, school climate is an important psychological construct. The school climate affects the motivation of employees and the behaviour of teachers, but it also affects the construction of the teacher’s identity.

The role of organizational culture and climate is important because it depends on building the reputation of the school that consequently leads to the construction of the image [2]. Since the school climate is strongly influenced by the formal and informal organization, the way the school is managed and led, we present the characteristics of the school as an organization.

TABLE II. SCHOOL ROLES AND THEIR RELATION TO THE SOCIETY

Social	Communicative	Pedagogical
Qualification	Interaction	Upbringing
Tradition	Relationship	Education
Institution	Cooperation	Participation

## B. School management and organization

SC occurs as a transmission between the external environment and school activities. Since cultural values can activate and motivate teachers and direct their behaviour towards the common goals of the school, it is important to balance between internal and external integration of the organization. Exclusively market-oriented private schools have a problem with internal integration.

This tells us that the connection of SC, the productivity of teachers and the success of the provided service requires certain characteristics of culture: formal and informal elements. We view the formal elements of SC as visible signs that are easily recognizable, such as school symbols, ceremonies, and teacher behaviour. However, the invisible signs are the common values of the school, attitudes, and beliefs of the teachers [14,15].

Since SC is intertwined in all school activities, it affects the way of organization, type of management and degree of decentralization [9]. Also, SC affects the type of school management, degree of formalization, standardization, school climate and HR. In this context, SC not only represents cause and effect, but also shapes the strategy of SM. Furthermore, SC shapes both the identity of the school and the identity of the teacher.

Bureaucratic organization is characterized by deep and detailed division of labour, high specialization of jobs, standardized policy, centralization, many rules, rewards based on loyalty to superiors [20,21] and lack of innovation (see Table III).

Bureaucratic culture is based on the logic of diversity, which leads to greater obligations of employees, and numerous rules and procedures. SC belongs to the area of bureaucratic culture because rules, curriculum and procedures are more important than the employees themselves. Employees are expected to work according to the adopted curriculum.

TABLE III. CHARACTERISTICS OF THE SCHOOL ORGANIZATION

Characteristics	Impact
Teacher’s contribution	Indirectly
The flexibility of school	Small impact
School hierarchy	Significant impact
Decision-making style	Autocracy
Communication	Vertical



According to Handy [20], bureaucratic culture is metaphorically shown as a Greek temple, where the pillars are the elements on which the power of the bureaucracy rests. Power is based on the position held by the principal (hierarchy). The main means of influence are laws, regulations, processes, and procedures.

School management starts from the functions of management in education, and we observe it through four key functions: administration, leadership, management of employees and the school as an organization [22,23]. Since school management depends on administrative regulations, we can see it as an administrative-legal form that brings a centralized approach and slows down development [24].

#### IV. THE ROLE OF THE TEACHER

The teacher is the most valuable resource in education. According to recent research, the job of a teacher is very stressful [25,26]. There is a common correlation between employee behaviour and organizational culture [27,28]. The role of teachers in creating SC is huge because the satisfaction, motivation and perception of teachers create the reputation of the company. Building the school's identity and image is crucial precisely in the context of teachers.

The stability of the school is a consequence of SC, which is characterized by setting rules and procedures for all jobs. Managerial decisions influenced by culture are planning, organizing, leading, and controlling [29,30]. One of the key indicators of SC are teachers and their satisfaction with their work and the service provided. From the aspect of service marketing, corporate culture is a holistic phenomenon [31,32].

The identity of the teacher can be most simply presented as the teacher's sense of self-worth and reflection on those values [33]. The teacher professional identity construct is based on the psychological-sociological aspect of the teacher's identity and job satisfaction. Some researchers claim that teacher professional identity refers to how teachers see themselves [33,34]. However, the teacher's identity can be viewed from the aspect of motivation and recognition in society [35], but also from the aspect of the curriculum [36].

Teacher professional identity is associated with a sense of job satisfaction, permanent

motivation, commitment to work and a sense of self-reflection [37-39]. Beijrad [37] observes teacher professional identity according to the attitude towards students, the subject taught and the role of the teacher in the school. The role of the teacher in the school is crucial for the construction of SC because it includes personal norms, values and belonging to the school.

However, the teacher's identity is not a one-dimensional construct, the identity is multiple [40]. It is also dependent, and it is formed within different environments that bring numerous social changes. Teacher identity is a changing and unstable concept [37,41,42] that includes constructions and reconstructions of SC [15].

Since there is no comprehensive definition of teacher professional identity [36], this study emphasizes the roles played by teachers in providing services. In this sense, teacher professional identity is crucial when creating SC because the roles they assume are the result of a harmonious relationship with others. Employee-based services, such as teaching, constitute a service in themselves. Investment in employees constitutes a direct investment in service (see Table IV).

Service providers represent their organization. The teacher becomes part of the service, but also part of the school's identity. The behaviour of teachers, their image, and identity affects the user's perception of that organization. In other words, the teacher is the key builder of SC and promoter of the school. In this sense, the role of the teacher in the context of marketing is seen as a service.

#### V. SCHOOL IDENTITY

At the centre of SC are common values, norms and customs that keep teachers together [10,12,25]. The mission of the school consists of purpose (the goal of the school's existence) and values (the core of the school's beliefs). Since a well-defined mission of the school motivates employees, and satisfied employees build a positive school climate and SC, the vision of the school directs the school towards what it wants to become.

However, SC is affected by some factors, such as the mutual relations between teachers and students, teachers and other stakeholders of the school, the relationship of the principal and the way the school is led and managed. Since school leadership plays a key role in SM

TABLE IV. TEACHER AND SCHOOL DIMENSIONS IN SM

Teacher	School
Service	Teaching
Collective	SC
Identity	Reputation
Promoter	Brand

influencing SC, principals must have a strong desire and ability to determine the school’s cultural values. This is the reason the collaborative and partnership approach of principals and teachers has proven to be the most successful when running a school [10,25].

The concept of corporate identity [43] is essential for SM. To emphasize the importance of corporate identity, Balmer [6,7,44,45] uses the metaphor of fog [6] to highlight the isolation of an organization’s identity. In this sense, the *fog* represents the isolation of SM in the pedagogical and economic world because the principals do not see the importance of SI and a holistic approach to corporate marketing.

Corporate identity communicates on a symbolic level and is aimed at internal and external factors of the school. Therefore, the understanding of SI is like the understanding of organizational culture because it starts from the common beliefs, attitudes, and opinions of the employees of an organization. The school’s identity can be defined most simply as the individual characteristics of the school that differentiate it from other schools. The SI construct itself is an expanded understanding of brand identity [8] as a set of associations that are in the minds of consumers.

Brand identity, according to Kapferer [46], is presented in a hexagonal form where the internal and external factors of self-concept and image are covered in detail. What is important in the context of corporate identity is that it refers to the desired identity of a particular organization. In the analysis of the teacher’s role [33] and the AC<sup>2</sup>ID Test [47] in school management [28], a model was presented that can serve as a method of identifying different SI. In other words, the identity stated by Balmer, i.e., actual identity, communicated identity, conceived identity, ideal identity, and desired identity, reflect on the image of the school and the identity of the teacher.

This means that teachers create SI. Teachers create a corporate identity with their work and quality of service. The differences between identities that can be analysed with the AC<sup>2</sup>ID

Test model [47] are designed to enable strategic leadership and management of the school and to set the possibilities of diagnosing existing identities (see Table V).

A discrepancy between SI and other factors can lead to potential risk. If the real identity reflects the internal stakeholders, it is reflected in the teachers and the teacher’s image. However, there is dissonance in analysing SI because according to the AC<sup>2</sup>ID Test [7,43] it is possible that the communicated identity is not consistent with the real identity or that the principal’s vision of the school (desired identity) conflicts with the school’s strategy (ideal identity). Therefore, we can conclude that there are different SI within one school.

Corporate reputation is an important part of any organization [48]. Intangible assets such as a school’s reputation and identity are a key factor in achieving competitive advantage. However, the reputation of an organization is built over time and as a corporate structure is very fragile [49]. The term “reputational risk” refers to the probability of an organization losing corporate reputation [50].

We understand enterprise risk management (ERM) as the management and monitoring of the organization’s risks, in this case, for the purpose of increasing the short-term and long-term value of the school. The goal of ERM in schools is to create value and reduce the consequences of risk and to ensure the realization of the company’s latent value [51]. In order for ERM to be effective in a school, it needs to be implemented systematically. Risk is seen as an opportunity, not just a threat.

ERM can reduce reputational risk and we can observe it through two models: direct and indirect [49]. The first model, with a direct effect, reduces the probability of suffering a crisis in the organization, and the second model, with an indirect effect, results from a reduction in the attribution of blame during a crisis [52].

In this sense, SI, as well as the image of the

TABLE V. AC<sup>2</sup>ID TEST AND SCHOOL CULTURE

Identity	School impact
Actual	Teacher’s identity
Communicated	School climate
Conceived	School image
Ideal	Teacher’s loyalty
Desired	Principal expectations

school, represent an intangible asset that needs to be protected and managed. ERM protects and adds value to the organization by developing and supporting employees, increasing the ability to attract needed teachers, protecting the image of the school and improving the decision-making process during a crisis.

Examples of ERM in a school can be: long-term absence of a principal or class teacher, when it is necessary to provide a substitute, giving power of attorney to lower management (school board), establishing an intervention team and digitization. All this can reduce a potentially negative school image and difficulties in the functioning of the organization. If schools invest in the strategy of building SI and perceive the image of the school in a positive way, the quality of the school increases and the risk of a bad reputation decreases. SI is connected to the reputation of the school because it is built together by teachers through SC.

Many organizations accept social responsibility as a strategic position [48]. An example of building corporate social responsibility (CSR) for schools is the establishment of associations that promote lifelong education, the creation of alumni who will cooperate with the school, participation in sports activities, volunteering, humanitarian actions and student scholarships. CSR is a major factor in building corporate reputation [49,53,54]. Also, the quality of ERM indirectly affects corporate reputation and SI through CSR.

Ultimately, SM can influence the prevention of risks to the school's reputation, SI and image perception by maintaining a high level of SC and developing good collegial relations, monitoring the quality of service, respecting teachers and through CSR. All the mentioned factors are strongly related to SC and form the basis of SI construction in terms of marketing and management.

Corporate image is the overall impression in the user's mind towards the school. It is a set of impressions that the school creates towards the public, but also the sum of associations by external stakeholders. Therefore, we understand the corporate image as the image of the school. It is an expression of SI and is firmly grounded in SC. However, the image of the school can also be understood as part of the expected value that students, parents and society expect.

Therefore, the creation of the school brand is in the SI concept that creates and shapes the image of the school. The advantages of building an identity are creating strength, a recognizable school brand, developing the identity of teachers, establishing a positive SC, and creating a competitive advantage. SM based on the creation of SI must start from the control and management of the identity to build a desirable identity and thereby diversify the brand.

SC is key in creating SI because teachers' satisfaction and their positive self-concept that builds elements of culture (formal and informal) is a key predictor in creating community, beliefs, attitudes, and behaviour. Principals should lead the school and manage the SC because they are the ones who determine the central values, goals, and strategy of the school. They should also ensure a stimulating environment, provide systems that strengthen SC through models of ceremonies, behaviour, and services [12,14].

Since SC is a set of values, attitudes, and behaviours of teachers, it is an important predictor of SI identification, and the creation of a school as a brand. SC is viewed as a system of common meanings and this construct allows us to view SC as a homogeneous group of teachers who make up the connective tissue of each school. It is a psychological construct of the workplace environment that is formed from mutual interaction. And it is precisely such a community and its members that make up the promoters of the brand, as well as the main service providers. Their satisfaction, identity and self-image form a social system of economic and pedagogical aspects.

## VI. CONCLUSION

The role of the principal needs to change. The quality of the school and its changes depend on him, but the quality of the service provided, and the identity of the school strongly depends on the teachers. Successful school principals should have a holistic view of the school where interpersonal relationships are in the first place because positive SC [25] is created from the satisfaction and identity of teachers. In this sense, principals in SM should support the school as an institution that learns and better understands teachers and students.

The teacher is the most important resource in the school. The role of the teacher is huge because he, as the bearer of the entire education of the school, is key in the development of a

positive school climate [12], but also key in the development of SC construction. The special quality of the teacher's work stems from the pedagogical approach, job satisfaction and self-image. The teacher's identity is a complex construct that supports the overall construction of SC.

Since the roles of teachers are changing, new roles of the school are also needed. The identity of the teacher, as well as the identity of the school, are not permanent categories [7,10,25] and they can change very often. It is necessary to establish new forms of cooperation and communication to harmonize the school leadership with the teachers [55]. The school is an institution that requires teamwork.

The actual identity of the school does not have to agree with the identity of the school as desired by the principal. The principal should be able to change the way of thinking and behaviour in accordance with the current situation. In this sense, the principal's role in the creation of SC is advisory and supportive. Preference should be given to a cooperative and partnership approach. However, as long as the principal's role is based on hierarchical power and administration [23,33], in the form of a semi-professional manager [56], and not on true leadership, schools cannot develop.

#### REFERENCES

- [1] Pigisch, U. (2010). *Kompetenzen von BildungsmanagerInnen in der Erwachsenenbildung*. VDM Müller.
- [2] Jukić, D. (2022). The Importance of Organizational Climate in Cultural Organizations. In *Proceedings of the PaKSoM 2021 3rd Virtual International Conference Path to a Knowledge Society-Managing Risks and Innovation* (pp. 131-138). Research and Development Center, Niš.
- [3] Mayring, P. (2016). *Einführung in die qualitative Sozialforschung*. Beltz Verlag.
- [4] Willig, C. (2013). *Introducing qualitative research in psychology*. Open University Press.
- [5] Larkin, M., Watts, S., & Clifton, E. (2006). Giving voice and making sense in interpretative phenomenological analysis. *Qualitative Research in Psychology*, 3(2), 102-120.
- [6] Balmer, J. M. T. (2001). Corporate identity, corporate branding and corporate marketing, seeing through the fog. *European Journal of Marketing*, 35(3/4), 248-291.
- [7] Balmer, J. M. T., & Gray, E. R. (2003). Corporate brands: what are they? What of them? *European Journal of Marketing*, 37(7-8), 972-997.
- [8] Keller, K. L. (2013). *Strategic Brand Management*. Pearson Education.
- [9] Stoll, L. (1998). School Culture. *School Improvement Network's Bulletin*, 9, 9-14.
- [10] Stoll, L., & Fink, D. (2003). *Changing our schools: Linking school effectiveness and school improvement*. Open University Press.
- [11] Luhmann, N. (2010). *Gesellschaftsstruktur und Semantik. Studien zur Wissenssoziologie der modernen Gesellschaft*, 4. Bände. Suhrkamp.
- [12] Göhlich, M. (2009). Schulkultur. In H. J. Apel & W. Sacher (Eds.), *Studienbuch Schulpädagogik* (pp. 104-121). Klinkhardt.
- [13] Reckwitz, A. (2004). Die Kontingenzperspektive der ‚Kultur‘. Kulturbegriffe, Kulturtheorien und das kulturwissenschaftliche Forschungsprogramm. In F. Jaeger & J. Rüsen (Eds.), *Handbuch der Kulturwissenschaften* (pp. 1-20). Band III: Themen und Tendenzen.
- [14] Helsper, W. (2008). School cultures - the school as a symbolic order of meaning [Schulkulturen - die Schule als symbolische Sinnordnung]. *Zeitschrift für Pädagogik* 54(1), 63-80.
- [15] Peterson, K. D., & Costner, S. (2006). Encyclopedia of educational leadership and administration. In F. W. English (Ed.), *Encyclopedia of Educational Leadership and Administration* (pp. 249-50).
- [16] Zech, R. (2010). *Management in der Weiterbildung*. Weinheim.
- [17] Merk, R. (2006). *Weiterbildungsmanagement – Bildung erfolgreich und innovativ managen*. Ziel.
- [18] Schneider, B., Ehrhart, M. G., & Macey, W. H. (2013). Organizational Climate and Culture. *Annual Review of Psychology*, 64(1), 361-388.
- [19] Bowen, D. E., & Schneider, B. (2014). A Service Climate Synthesis and Future Research Agenda. *Journal of Service Research*, 17(1), 5-22.
- [20] Handy, C. B. (2006). *Understanding Organizations*. Penguin Books.
- [21] Wagner-Herrbach, C., & Skenderski, Y. (2020). Pädagogisches Führen – Anforderungen an die Professionalität von Schulleitungen. In S. Brauckmann (Ed.), *Erziehung & Unterricht Führung in der Schule wahrnehmen: Erkenntnisse aus Forschung, Beratung sowie Aus-, Fort- und Weiterbildung von Schulleitungen* (pp. 4-14). Österreichischer Bundesverlag Schulbuch GmbH & Co. KG.
- [22] Altrichter, H., Matthias, R., & Schuchart, C. (2016). Schulautonomie und die Folgen. In H. Altrichter & K. Maag-Merki (Eds.), *Handbuch Neue Steuerung im Schulsystem* (pp. 107-150). Springer.
- [23] Jukić, D. (2017). The Importance of Corporate Branding in School Management. *Strategic Management*, 22(4), 11-18.
- [24] Rosenbusch, H. (2005). *Organisationspädagogik der Schule: Grundlagen pädagogischen Führungshandelns*. Luchterhand und Carl Link.
- [25] Harmsen, R., Helms-Lorenz, M., Maulana, R., & van Veen, K. (2018). The relationship between beginning teachers' stress causes, stress responses, teaching behaviour and attrition. *Teachers and Teaching*, 24(6), 626-643.
- [26] Newberry, M., & Allsop, Y. (2017). Teacher attrition in the USA: The relational elements in a Utah case study. *Teachers and Teaching*, 23(1), 863-880.

- [27] Mullins, L.J. (2006). *Essentials of Organizational Behavior*. Prentice Hall Financial Times.
- [28] Jukić, D. (2020). Synesthesia of HR and School Culture. In M. Stanković & V. Nikolić (Eds.), *Proceedings of the PaKSoM 2020 2nd Virtual International Conference Path to a Knowledge Society-Managing Risks and Innovation* (pp. 265-272). Research and Development Center, Niš.
- [29] Robbins, S. P., & Coulter, M. (2005). *Management*. Pearson Prentice Hall.
- [30] Robbins, S. P., & Judge, T. A. (2007). *Organizational Behavior*. Pearson Prentice Hall.
- [31] Grönroos, C. (2007). *Service Management and Marketing: Customer management in Service Competition*. John Wiley Sons.
- [32] Grönroos, C. (2009). Marketing as promise management: regaining customer management for marketing. *Journal of Business & Industrial Marketing*, 24(5-6), 351-359.
- [33] Jukić, D. (2022). The role of teacher and organizational culture in school management. *Strategic Management*, 27(2), 17-28.
- [34] Canrinus, E. T, Helms-Lorenz, M, Beijjaard, D, Buitink, J., & Hofman, A. (2011). Profiling teachers' sense of professional identity. *Educational Studies*, 37(5), 593-608.
- [35] Castaneda, F., & Alberto, J. (2014). Learning to Teach and Professional Identity: Images of Personal and Professional Recognition. *Profile Issues in Teachers' Professional Development*, 16(2), 49-65.
- [36] Karousiou, C., Hajisoteriou, C., & Angelides, P. (2019). Teachers' professional identity in super-diverse school settings: teachers as agents of intercultural education. *Teachers and Teaching*, 25(2), 240-258.
- [37] Beijjaard, D. (1995). Teachers' Prior Experiences and Actual Perceptions of Professional Identity. *Teachers and Teaching*, 1(2), 281-294.
- [38] Beijjaard, D., Verloop, N., & Vermunt, J. D. (2000). Teachers' perceptions of professional identity: An exploratory study from a personal knowledge perspective. *Teaching and Teacher Education*, 16(7), 749-764.
- [39] Beijjaard, D. (2019). Teacher learning as identity learning: models, practices, and topics. *Teachers and Teaching*, 25(1), 1-6.
- [40] Vondracek, F. (2006). Identity. In J. H. Greenhaus & G. A. Callanan (Eds.), *Encyclopedia of Career Development* (pp. 371-374). Sage Publications.
- [41] Rodgers, C. R., & Scott, K. H. (2008). The development of the personal self and professional identity in learning to teach. In M. Cochran-Smith, S. Feiman-Nemser, D. J. McIntyre & K. E. Demers, (Eds.), *Handbook of Research on Teacher Education* (pp. 732-756). Routledge.
- [42] Lamote, C., & Engels, N. (2010). The development of student teachers' professional identity. *European Journal of Teacher Education*, 33(1), 3-18.
- [43] Balmer, J. M. T., & Greyser, S. (2003). *Revealing the Corporation*. London.
- [44] Balmer, J. M. T. (2001). The Three Virtues and Seven Deadly Sins of Corporate Brand Management. *Journal of General Management*, 27(1), 1-17.
- [45] Balmer, J. M. T. (2012). Strategic corporate brand alignment. *European Journal of Marketing*, 46(7/8), 1064-1092.
- [46] Kapferer, J. N. (2008) *The New Strategic Brand Management*. London.
- [47] Balmer, J. M. T., & Greyser, S. A. (2002). Managing the Multiple Identities of the Corporation. *California Management Review*, 44(3), 72-86.
- [48] Miotto, G., Del-Castillo-Feito, C., & Blanco-González, A. (2020). Reputation and legitimacy: Key factors for higher education institutions' sustained competitive advantage. *Journal of Business Research*, 112, 342-353.
- [49] Pérez-Cornejo, C., & de Quevedo-Puente, E. (2022). How corporate social responsibility mediates the relationship between corporate reputation and enterprise risk management: evidence from Spain. *Eurasian Business Review*, 1-21.
- [50] Nujen, B. B., Solli-Saether, H., Mwesumo, D., & Hammer, B. (2021). Reputational risk as a factor in the offshore location choice. *Journal of Purchasing and Supply Management*, 27(2), 100682.
- [51] Pickford, J. (2001). *Mastering Risk, Volume 1: Concepts*. Financial Times/Prentice Hall.
- [52] Xu, S. (2018). When individual cultural orientation and mediated portrayal of risk intersect: Effects of individualism-collectivism and media framing on risk perception and attribution of responsibility. *Journal of Contingencies and Crisis Management*, 26(4), 499-509.
- [53] Børing, P. (2019). The relationship between firm productivity, firm size and CSR objectives for innovations. *Eurasian Business Review*, 9(3), 269-297.
- [54] Pérez-Cornejo, C, de Quevedo-Puente, E, & Delgado-García, J-B. (2019). How to manage corporate reputation? The effect of enterprise riskmanagement systems and audit committees on corporate reputation. *EuropeanManagement Journal*, 37(4), 505-515.
- [55] Hericks, U. (2004). Entwicklungsaufgaben, Habitus und Professionalisierung von Lehrerinnen und Lehrern. In M. Trautmann (Ed.), *Entwicklungsaufgaben Bildungsgang* (pp. 117-135), VS Verlag für Sozialwissenschaften.
- [56] Terhart, E. (2011). Teaching and professionalism. Changed understanding of terms - new challenges. [Lehrerberuf und Professionalität. Gewandeltes Begriffsverständnis – neue Herausforderungen]. In W. Helsper & R. Tippelt (Eds.), *Pädagogische Professionalität. Zeitschrift für Pädagogik*, 57 (pp. 202-224). Beiheft.

# Data Protection in Innovation under the European Union Legislation

Iris Bjelica Vlajić<sup>1</sup>

<sup>1</sup>Ministry of Defense, Belgrade, Serbia

<sup>1</sup>iris\_bjelica\_vlajic@yahoo.com

**Abstract**—Technology development impacts natural person’s life and privacy obliging states to set data protection standards. Data protection is granted by both international and national regulations. Inevitably, these data protection regulations influence the innovation process. The European Union (EU) legal framework is regulating different aspects of the data protection providing certain rights and obligation for all participants of the innovation process. The aim of this paper is to provide an answer to a question what are data protection requirements to innovation and are they restraining or stimulating innovation process. In answering this question, historic methods and method of the content analyses were used. The paper is divided into chapters in order to provide coherent analyses of sub topics starting with the EU requests and harmonized national rules.

**Keywords** – data protection, innovation, EU legislation

## I. INTRODUCTION

Personal data mean any information or piece of it which, directly or indirectly, could identify a living person. Traditionally it refers to a name, phone number and address. Hence, some other information is also considered personal data as it could identify a person. Those are interests, information about past purchases, person’s health and online behavior. Personal data belong to the individual who is known as a personal data subject. Use of personal data is acceptable when it is based on legal obligation (when necessary or requested by legal act or in the public interest) or if it is consensual. Consent is a voluntary, specific, informed and unambiguous expression of the will of a person, by which that person in a form of statement or clear affirmative action, gives

consent to the processing of personal data relating to him/her. Given consent may be withdrawn by the subject at any time during processing. Processing data means different activities and it refers to collecting, structuring, organizing, using, storing, sharing, disclosing, erasing and destruction of data. Data should be erased or, destroyed in other way, when no longer needed. Personal data should not be storage for future needs.

Innovation is a way of expanding or improving human knowledge. It may be result of the research although it is not mandatory. Innovation is possible in all fields of human existence by improving certain processes, methods or products and services. The need for use of personal data during innovation is inevitable. Data helps developing business models, gaining an understanding of customers, conducting effective marketing campaigns or developing improved products and services. In medicine and other related fields huge amounts of personal data are necessary in order to compare results and extract scientific conclusions. During all these activities it is obligatory to provide legal grounds for collection and protection of the data. With the fourth industrial revolution and extended use of information technologies, exchange of various information multiplied. At the same time, privacy became an important issue [1]. “The technological development necessitated the implementation of further measures in order to keep up with legal requirements” [2].

One of the results of that revolution is the growing possibility of misuse of data or violation of privacy which is more and more challenged by increasingly intruding technologies [3].

Each personal data carries huge amounts of information that reveals their subject. States and international organizations are providing legal framework under which processing of personal data is done. According to the Article 8 of the Charter of Fundamental Rights of the European Union (the Charter) and Article 16 of the Treaty on the Functioning of the European Union (TFEU) protection of natural persons in relation to the processing of personal data is a fundamental right that everyone has. There are, also, internal rules in the majority of research institutions or enterprises that are covering data protection. This legal framework is being periodically changed providing adequate protection that runs parallel with new technical achievements.

Protection of data and privacy involves broader scope of stakeholders since ethical implications of data use affect society both socially and financially [4].

## II. DATA PROTECTION IN INNOVATION

The innovation is seen as the creation of new knowledge and so it has social dimension [5]. Mostly, innovation is linked to start-up companies which by definition bring some improvements and innovative approaches, or innovation of non-compliant products/services. It is the flexibility and strong innovation-orientation of start-ups that is particularly likely to identify and exploit regulation-induced opportunities for innovation [6].

In this way, innovation is possible in marketing or economy as well in technological processes and medicine. Different data are necessary to explore impacts that products and services have on consumers. "In as far as regulation imposes constraints on some companies, however it also creates a positional market opportunity for others, and thus a fourth possible response: innovating solutions to help companies achieve compliance without damaging their regular production and value-creation activities [7]. In that sense, new product design or new suppliers are needed in order to protect data and privacy becomes market opportunity. Modern societies rely on research and innovation to solve their problems [8]. Research represents extension of human knowledge that has certain process and final product or outcome. It includes collection, use and protection of data as well as the ways of linking them. Protection of privacy affects development of new methodologies hence it

incorporates ethical values into technology. Not all of them are visible to publicity. Problem lays in the chosen methodology for particular field that has to use the best solution of maximum data with minimum intrusion. Data protection during preparation for research and innovation is known as "responsible research and innovation (RRI)" and it has to use the technologies in socially acceptable, desirable, and sustainable way [9].

The use of legal means only in assuring data protection is not sufficient yet it is necessary to include new ways and instruments of protection. Having in mind wide scope of human activities that may be innovated as well as scopes of scientific research, the EU adopted two different legal documents regulating the matter. The first is dealing with general rules and principles of the data protection including all market oriented innovation while the other deals exclusively with the data protection in clinical trials.

### A. *General Rules and Principles*

The EU adopted a General Data Protecting Regulation (GDPR) replacing the 1995 EU Data Protection Directive (DPD) and introduced severe fines for breaches and new restrictions [10]. The main goal was to provide equal treatment of all at the EU market as well as to keep the trust into electronic trade. In achieving their goals of equalization of standards in all member states, the EU uses different instruments. The most common are regulations and directives. A regulation is a legal act of the EU that becomes immediately enforceable as law in all member states simultaneously unlike directives which need to be transposed into national law, according to that national law hence preserving main goals and the ratio for which they were adopted. However, the EU depends on its member states in order to execute these provisions. In that sense, European legal framework consists of the European laws, such as the GDPR, the following Directives and national laws that need to be harmonized with them in order to provide equal and uniform protection in the entire territory of the EU in order to protect people from two threats: irregular attacks on people's data by criminal outsiders ("hackers") or insiders acting in contravention of their organization's rules; and from people's data being processed illegally by organizations acting in accordance with their international (but illegal) rules and objectives as stated

in [7]. It is worth saying that “yet it is unlikely that the effects of data protection regulation are uniform, since the types of data firms employ, the ways they use it and their relations to end users vary substantially” [11]. Other authors find the new European legislation positive as it provides a number of different voices to be heard by its pluralist approach [12].

Crossing needs of research and innovation for new and multiple data with the EU legislative standards of data protection creates a theoretical situation on which present European legal requirements might be obstacles for innovative products or processes. Finally, we end up with two possible outcomes. The first “the main potential negative, innovation-constraining response that our theoretical framework identified was product abandonment, that data protection regulation might prompt firms to respond by abandoning products or products ideas that were judged fundamentally incompatible with the regulation”, while the second would be adjustment to those requirements through reorganization [11]. Notable examples are privacy, data protection and surveillance as well as issues of property, ownership and digital divides. While these problems will not disappear, they have been well recognized and there are institutions, norms and regulations that aim to address them [12].

In the preamble GPDR states that the processing of personal data should be designed to serve mankind hence the proper functioning of the internal market and free movement of people influenced data protection provisions. The EU need to protect micro, small and medium-sized enterprises is apparent in the document where the right to the protection of personal data is not an absolute right; it must be considered in relation to its function in society and be balanced against other fundamental rights, in accordance with the principle of proportionality. So, the Regulation does not therefore concern the processing of anonymous information, including ones gathered for statistical or research purposes.

Special attention is paid to consent as one of the basis for data processing. GPDR allows any form of statement regardless if it is written statement or an oral statement, including statement given by electronic means, which includes ticking a box when visiting an internet website, choosing technical settings for

information society services or another statement or conduct which clearly indicates in this context the data subject's acceptance of the proposed processing of his/her personal data. Consent should cover all carried out processing activities. Exceptions are set for the case where processing is carried out for archiving purposes in the public interest, scientific or historical research purposes or statistical purposes, although in these cases appropriate safeguards for the rights and freedoms of the data subject should be granted. Those safeguards should ensure that technical and organizational measures are in place in order to ensure, in particular, the principle of data minimization. Any processing of personal data revealing racial or ethnic origin, political opinions, religious or philosophical beliefs, or trade union membership, and the processing of genetic data, biometric data for the purpose of uniquely identifying a natural person, data concerning health or data concerning a natural person's sex life or sexual orientation is forbidden except if necessary for archiving purposes in the public interest, scientific or historical research purposes or statistical purposes as long as proportionate to the aim pursued, respect the essence of the right to data protection and provide for suitable and specific measures to safeguard the fundamental rights and the interests of the data subject.

Where personal data are processed for scientific research purposes, the Regulation should apply to that processing and the processing of personal data for scientific research purposes should be interpreted in a broad manner: including technological development and demonstration; fundamental research, applied research and privately funded research. Scientific research purposes should also include studies conducted in the public interest in the area of public health.

Statistical results may further be used for different purposes, including a scientific research purpose. Special attention was given to research results obtained through registries. These results provide solid, high-quality knowledge which can provide the basis for the formulation and implementation of knowledge-based policy or improve the quality of life or the efficiency of social services. By coupling information from registries, researchers can obtain new knowledge of great value and research results can be enhanced, as they draw on a larger population. Within social science,



research on the basis of registries enables researchers to obtain essential knowledge about the long-term correlation of a number of social conditions such as unemployment and education with other life conditions. In order to facilitate scientific research, personal data can be processed for scientific research purposes, subject to appropriate conditions and safeguards set out in the EU or Member State law.

The document strongly advises that a data protection officer should be designated where the data processing includes data subjects on a large scale. GDPR encourages the drawing up of codes of conduct as a specific mechanism intended to contribute to the proper application of the Regulation, taking account of the specific features of the various sectors and the specific needs of the enterprises processing data. The codes approved and validated by relevant national authorities might be published for general information. The Article 47 provides possibility of adopting internally binding corporate rules that would include all relevant provisions dealing with data processing.

#### B. Clinical Trials

The Clinical Trials Regulation (CTR) is the second very important piece of legislation to which the GDPR makes express references [13].

According to its Article 47, the purpose of a clinical trial is to gather reliable and robust data on an investigational medicinal product, while following the approved protocol and the good clinical practice principles by investigator. The accent in clinical trials is on accuracy of data as well as their confidentiality so the CTR in Article 56 provides certain measures requiring the investigator to record, process, store and handle data in such a way that it can be accurately reported, interpreted and verified, while requiring appropriate technical and organizational measures to protect information and personal data. Additionally, the clinical trial protocol, authorized under the CTR, defines the purposes and conditions for which the data of clinical trial subjects will be processed. Subjects should be properly informed on the processing of his/her personal data. Every investigator is a subject to national inspections in order to establish abidance to those principles. This means that every institution conducting such trials is hold accountable to implement the appropriate

technical and organizational measures to ensure and be able to demonstrate that the personal data are processed in accordance with the data protection rules. This requests that any institution performing clinical trial has to obey GDPR, CTR and national rules regarding data protection.

Processing operations purely related to research activities in the context of a clinical trial cannot, however, be derived from a legal obligation that falls under one of the three legal bases, depending on the whole circumstances attached to a specific clinical trial: scientific research, public interest and subject's consent. Scientific research means a research project set up in accordance with relevant sector-related methodological and ethical standards, in conformity with good practice. The CTR defines certain processing activities, which are necessary for the performance of a task carried out in the public interest or in legitimate interest or with the subjects consent. The pursue the general public interest of the Union in safeguarding public health exists for purposes outlined in the approved clinical trial protocol or when the conduct of clinical trials directly falls within the mandate, missions and tasks vested in a public or private body by Union or national law. The legitimate interests which is not a public interest is pursued by the controller or by a third party, except where such interests are overridden by the interests or fundamental rights and freedoms of the data subject, according to the definitions provided by GDPR. The same act describes consent as freely given, specific, informed, unambiguous, and where consent is used as a justification for processing special categories of data, such as health data, such consent must be explicit and it is procedural obligation, a *condition sine qua non* for person's participation in the trial. However, withdrawal of the informed consent to participate in a clinical trial shall not affect activities already carried out or the use of data obtained on the basis of the informed consent before that withdrawal if it was done in accordance with the protocol and legal requirements. In a situation where consent may be sought from the clinical trial subject for the use of personal data concerning that subject outside that clinical trial protocol for future scientific purposes the CTR in Article 28 allows secondary use of data provided it is anonymised, there is a valid legal basis and data protection principles are being obeyed.

The CTR expressly addresses risk of power imbalance between investigator and subjects and requires the investigator to take into account all relevant circumstances that could inappropriately influence her or his decision to participate.

### III. SERBIAN NATIONAL LEGISLATION

According to the Law on Innovation Activity an innovation is the successful market application of an invention, such as application new or significantly improved product, process or service or marketing methods or new organizational methods in business, organization of work or relations of a legal entity with the environment [14]. Yet, the Law has no provisions dealing with duty to protect data during innovative activities.

Republic of Serbia enacted a new Data Protection Law in 2018 [15]. The Law's effective date was postponed while all other laws regulating partially data protection have to be harmonized with it. Updated data protection law better aligns with the EU General Data Protection Regulation.

The law deals with any automated processing of data as well as non-automated processing if it is done in order to provide personal data information collections, as well as in case of marketing oriented goods offers or activity tracking.

Definitions given by the Law are more detailed and updated so personal data according to the Article 3 "is any data relating to a natural person whose identity is determined or determinable, directly or indirectly, in particular on the basis of an identity marker, such as name and identification number, location data, identifiers in electronic communication networks or one, that is, more features of his physical, physiological, genetic, mental, economic, cultural and social identity" while personal data processing is any action or set of actions performed automatically or non-automated with personal data or their sets, such as collecting, recording, sorting, grouping, i.e. structuring, storing, matching or changing, revealing, viewing, use, disclosure by transmission, i.e. delivery, duplication, dissemination or otherwise making available, comparison, restriction, deletion or destruction (hereinafter: processing). Besides, the law defines personal data breach, genetic and biometric data. Legal processing is processing

that is carried out in accordance with the law and according to the main principles of the purpose of processing, data minimization, accuracy, storage limitation and integrity and confidentiality. Processing that differs from the original purpose to which data is collected is forbidden with one exception. Namely, the Law acknowledges possibility of further processing if it is carried out for the purposes of archiving in the public interest, for the purposes of scientific or historical research, as well as for statistical purposes, in accordance with this law, it is considered that the data on individuals do not process in a way that is not in accordance with the original purpose. In accordance with the level of technological achievements, the nature, scope, circumstances and purpose of the processing, as well as the probability of the occurrence of risks and the level of risk for the rights and freedoms of persons implementation of appropriate technical, organizational and personnel measures in obligatory. The Law also provides possibility of associations and other subjects representing groups of handlers or processors to develop their codes of conduct for the purpose of more efficient application of the law, while the enterprises may adopt legally binding business rules that determine structure and contact information of the multinational company or group of economic entities, as well as each of its members and transfer or groups of transfers of personal data, including types of personal data, types of processing actions and their purpose, types of persons to whom the data refer and the name of the country to which the data is transferred and the manner in which the person to whom the data refer is provided with information about binding business rules.

### IV. CONCLUSION

The main value and importance of the personal data is that they reveal a lot about their holder's choices and behavior. Row data is used to create information and the information has its market value. Today, privacy varies between human right and costly privilege that requests need to include privacy-friendly approach into technology and innovation. Use of information technologies is putting data protection in risk, not only in a sense of unlawful acquisition but also danger of intellectual property theft. This has double negative impact hence without intellectual property protection, individuals and firms would not gain the full advantages of their

creations. Perspective of what protected data include changes because it is social category. Today one can see regulation by the states or other entities and self-regulation of data protection when some research institutions provide ethical guidelines or standards obligatory for their researchers and other participants or codes of conducts for staff. The main principles of the data processing remain the right to choice and the right to information while different fields of research (IT, biotechnology, and medicine) differ in preferences. “Data collection, use, and storage should contribute to ethical and sustainable development” [16]. Any research involving the collection, use and storage of data should be meaningful and purposeful, the data used for research purposes should be accurate and integral and depersonalized as much as possible, with a restrains in access to acquired data.

In order to keep internal market functional, the EU has a need for available and transferable data. The EU personal data definition is not applicable to encrypted data nor collection, analyses and storage of data which is not centralized, since the GDPR was fashioned for a world where data is centrally collected, stored and processed [17]. For all other types of data the GDPR is obligatory.

Crises request rapid innovation but they rarely comply with all requests regarding data protection. The Article 179 TFEU puts as one of Union's objective of achieving a European Research Area. That is why the overall objective of the CTR is to achieve a harmonized internal market as regards clinical trials and medicinal products for human use. A starting point for such objective is a high level of protection of health, high standards of quality and safety for medicinal products. At the same time, the overall objective of the GDPR is to protect fundamental rights and freedoms of natural persons and the protection of their personal data. The EU General Data Protection Regulation and the general data protection principles provided are the key to the successful deployment and adoption of new technologies. These principles require developers of new or existing technologies to implement privacy-friendly in their work even in case of crises. To sum up, some objectives of data protection may be achieved even in innovations and their mutual link has more positive than negative aspects.

## REFERENCES

- [1] Peissl, W. (2011). Responsible research and innovation in ICT: The case of privacy in Von Schomberg. In R. Von Schomberg (Ed), *Towards Responsible Research and Innovation in the Information and Communication Technologies and Security Technologies Fields* (pp. 35-46).
- [2] Peissl W (2011) *Responsible research and innovation in ICT: The case of privacy* in in Von Schomberg, R. (Ed). (2011) *Towards Responsible Research and Innovation in the Information and Communication Technologies and Security Technologies Fields, A Report from the European Commission Services.*
- [3] Hauptman, A., Sharan Y., & Soffer T. (2011). Privacy Perception in the ICT era and beyond. In R. Von Schomberg (Ed), *Towards Responsible Research and Innovation in the Information and Communication Technologies and Security Technologies Fields* (pp. 133-149)
- [4] Menevidis, Z., Swartzman, S., & Stylianidis, E. (2011). Code of Conduct for FP7 Researchers on medical and biometric data privacy. In R. Von Schomberg (Ed), *Towards Responsible Research and Innovation in the Information and Communication Technologies and Security Technologies Fields* (pp. 116-132)
- [5] Hayes, N., & Walsham, G. (2003). Knowledge sharing and ICTs: A relational perspective. In *The Blackwell handbook of organizational learning and knowledge management*, 54-77.
- [6] Siegfried, J. J., Sanderson, A. R., & McHenry, P. (2007). The economic impact of colleges and universities. *Economics of Education Review*, 26(5), 546-558.
- [7] Martin, N., Matt, C., Niebel, C., & Blind, K. (2019). How Data Protection Regulation Affects Startup Innovation. *Information Systems Frontiers*, 21, 1307-1324.
- [8] Stahl, B. C. (2013). Responsible research and innovation: The role of privacy in an emerging framework. *Science and Public Policy*, 40(6), 708-719.
- [9] Stahl, B. C., & Write, D. (2018). Ethics and Privacy in AI and Big Data: Implementing Responsible Research and Innovation. *IEEE Security & Privacy*, 16(3), 26-33.
- [10] Official name is the Regulation (EU) 2016/679 in April 27<sup>th</sup>, 2016. GPDR was published seven days later in the official journal L 119/2 and came into force in May 2018.
- [11] Martin, N., Matt, C., Niebel, C., & Blind, K. (2019). How data protection regulation affects startup innovation. *Information systems frontiers*, 21, 1307-1324.
- [12] Stahl, B. C. (2011). IT for a Better Future. How to integrate ethics, politics and innovation. In R. Von Schomberg (Ed.), *Towards Responsible Research and Innovation in the Information and Communication Technologies and Security Technologies Fields* (pp. 17-33).
- [13] Officially registered as the Regulation (EU) No. 536/2014 of April 16<sup>th</sup>, 2014 on clinical trials on medicinal products for human use, and repealing

Directive 2001/20/EC was published in the official journal L 158 on May 27<sup>th</sup> 2014.

- [14] The Law on Innovation Activity, “Official Gazette of RS”, No. 110/05, 18/10 and 55/13
- [15] Data Protection Law was adopted on November 9<sup>th</sup>, 2018 and published it in the “Official Gazette of RS” No. 87/2018. The Law’s effective date was postponed until August 21<sup>st</sup>, 2019.
- [16] Menevidis Z, Swartzman S, Stylianidis E. (2011). Code of Conduct for FP7 Researchers on medical and biometric data privacy, in in Von Schomberg, R. (Ed). (2011) Towards Responsible Research and Innovation in the Information and Communication Technologies and Security Technologies Fields, *A Report from the European Commission Services*.
- [17] Finck, M. (2018). Blockchains and Data Protection in the European Union. *European Data Protection Law Review*, 4(1), 17-35.



# Metaverse and its Impact in Healthcare

Sayani Ghatak<sup>1</sup>, Sayan Chakraborty<sup>2</sup>, Radha Debal Goswami<sup>3</sup>, Hrithik Paul<sup>4</sup>

<sup>1,4</sup>Dept. of CSE, JIS University, Kolkata, West Bengal, India

<sup>2</sup>Dept. of CSE, Swami Vivekananda University, Kolkata, West Bengal, India

<sup>3</sup>Department of Sensors and Biomedical Technology, School of Electronics Engineering, Vellore Institute of Technology, Vellore, India

<sup>1</sup>sgsayanighatak@gmail.com, <sup>2</sup>sayanc@svu.ac.in, <sup>3</sup>hrithikpaul2001@gmail.com,

<sup>4</sup>debal.goswami00@gmail.com

**Abstract**—Healthcare has experienced rapid growth due to the huge development of digitalization and automation, which has created new channels for serving patients at a lower cost. There are a variety of emerging technologies in the digital world, but metaverse technology is one of the most promising as it can facilitate real-time communication between patients and medical professionals. As a result of a combination of technologies, the Metaverse has been enabled, such as artificial intelligence, virtual reality, augmented reality, the internet of medical devices, robotics, quantum computing, and others. Providing quality healthcare services and treatments can be explored in new directions through this initiative. By combining these technologies, patients receive immersive, intimate, and personalized care. As well as removing barriers between healthcare providers and recipients, it provides adaptive intelligent solutions. Described in the article are the enabling technologies and potential applications of the Metaverse for healthcare.

**Keywords** - metaverse, healthcare, virtual reality, blockchain, augmented reality, extended reality

## I. INTRODUCTION

Recent trends in industries are forcing the organizations to dive into digital space to enhance the technologies to make it more efficient and compact. The metaverse [1,2] provides a digital performs that enables users to simulate reality in a multi user environment. In many industries, the metaverse is being used to carry out business agendas [3-5] and reduce costs while focusing on what really matters. Remote

work is also bringing greater attention to the use of metaverse platforms in order to give remote workers a sense of normalcy and a morale boost. Healthcare [6-8] is actively looking at metaverse to expand its future with it. This will open a window for the healthcare industry to put forward a feasible and accessible medical care to the most remote of places in the world. In Smart Health metaverse [9,10] can play an integral role by combining concept of telemedicine with smart healthcare. There can be several frameworks through which these can be done. Among such technologies, augmented reality and virtual reality are two most popular and advanced technology which is very much involved in the Metaverse as well.

Medical professionals can view a virtual model of a patient without physically being there. A body sensor network [11-14] can provide a way to enhance the range of motion as well as provide details of a patient's physiology to support decision-making. Machine learning [15,16] and artificial intelligence [17,18] have contributed to the rapid growth of virtual reality. As a virtual reality or augmented reality simulated environment, the metaverse [19] was developed to give machines their own version of thought. Its development has now evolved into facial recognition, natural language processing, 3D object scanning, blockchain [20-22], and digital twinning. Using machine learning, computers can be taught and trained to learn to perform tasks automatically. Research and engineers are using adaptable methods for usage within the metaverse to enhance the capabilities of new and

existing technologies. Cloud platforms and Internet of Things [23,24] advancements make the metaverse seem attainable. However, these spaces also present new threats and challenges. The healthcare industry, for instance, faces many unknown factors. The shared platform experience of a simulated [25], interoperable virtual environment can introduce vulnerabilities due to its ability to view pertinent, sensitive information remotely. The healthcare system can also be exposed to a wide range of risks from outside influences, such as body sensor networks [26-28] and smart devices [29,30]. An understanding of the possible risks and vulnerabilities can lead to the creation of potential hardening measures to increase trust and utilization.

The paper is organized with Section 2 discussing about existing technologies in Metaverse, while Section 3 describes challenges of Metaverse. Section 4 describes Metaverse based Smart Healthcare technologies and Section 5 tries to investigate applications of metaverse in healthcare. Paper concludes in Section 6.

## II. EXISTING TECHNOLOGIES IN METAVERSE

There is a variety of services that can be offered by a medical domain metaverse, including behavioral health, patient education, pain management, disease awareness, real-time E-surgery learning, and medical consultation [1]. It is impossible for the metaverse to adapt some services that require touch or percussion, such as surgical procedures and percussive examinations. The existing technologies of Metaverse are shown in Fig.1 and discussed in the current section.

### A. Blockchain

Blockchains are commonly misunderstood as the technology behind cryptocurrencies such as Bitcoin, but they are actually just distributed and encrypted databases that provide a way to securely store and transfer data that no one else can access. Many organizations share data inefficiently and in an opaque manner that is both inefficient and inefficient from the owner's perspective. A single health record is worth between \$70 and \$100 on the dark web since it is typically stored on centralized servers. Even for those who legitimately need it and accessing it can be lengthy and laborious.

### B. Extended Reality (XR)

Extended reality (XR) will be used in the metaverse to engage users with 3D content. A revolution in health communication can be stimulated by such XR platforms, which allow information-based content to move from a knowledge base to an experience base. As a result of manipulating users' threat and coping appraisals, XR affordances (presence, agency, and embodiment) can be used to improve healthy behavior across three major application domains. VR, in particular, can create realistic experiences that produce genuine emotional, cognitive, social, and behavioral responses based on abundant evidence

### C. Network and Communications

A network is made up of two or more computers and the links that connect them. A physical network is made up of the network's hardware (i.e., telephone lines, cables, and adapters). The logical network is composed of the software and the conceptual model. Different network and emulator types serve various purposes. There are several conceptual models for describing how networks function as a result of the complexity of modern computer networks. The Open Systems Interconnection (OSI) Reference Model from the International Standards Organization, generally known as the OSI seven-layer model, is one of these models that is used the most frequently.

### D. Layers of Computing

In fog computing, the measured data is processed on sensors or devices close to sensors rather than on cloud servers or remote healthcare centers. Fog computing and cloud computing are on the rise due to the increasing amount of patient data. In 2021, Sodhro and Zahid [28] proposed the creation of a pathology location framework using deep learning algorithms to create a smart healthcare system. It is possible to recognize pathology based on electroencephalogram signals.

A single layer infrastructure cannot handle huge computation needs in the metaverse. Rendering of images and videos is a core component of metaverse. Hence 3 layers of computing in the metaverse is proposed as shown in the figure below. The layers are listed below.

- a) Cloud Computing Layer,
- b) Fog Computing Layer,
- c) Edge Computing Layer.

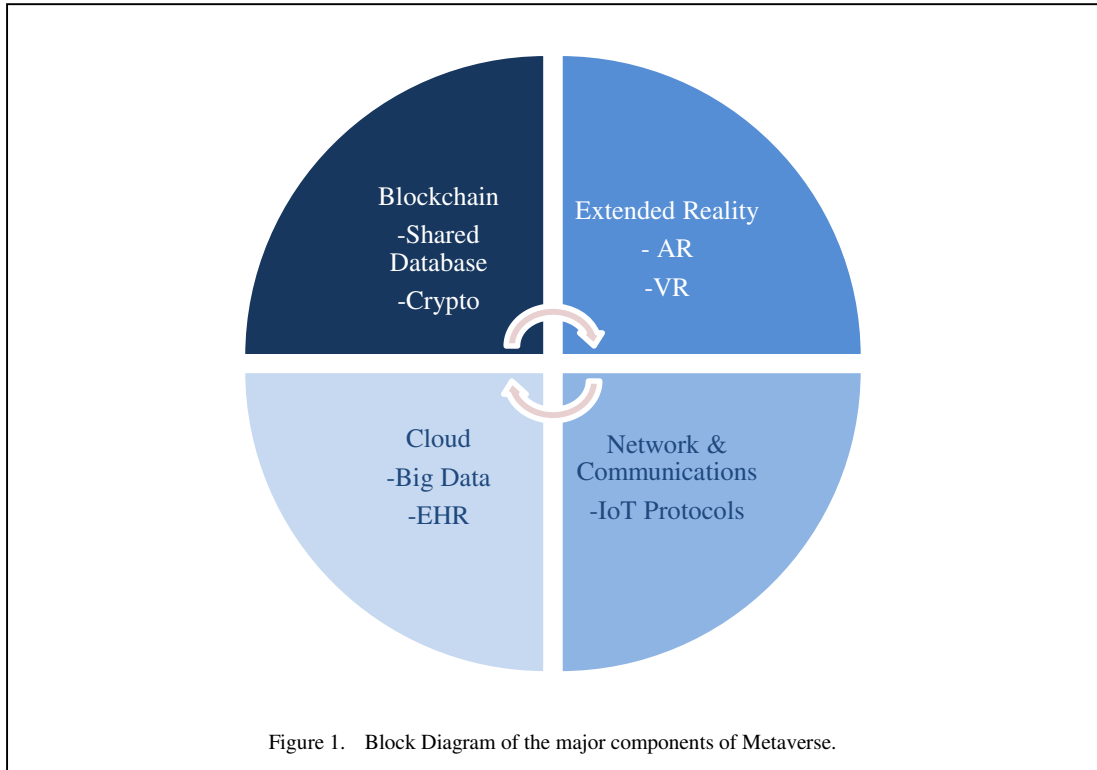

The metaverse is resource and computing hungry. It needs a huge amount of computation power, storage space and fast and advanced communication technology. Moreover, with the increase of user base cloud computing is must and essential for any metaverse application. Cloud gaming is one the use case of cloud computing for metaverse as discussed below.

Fog computing is the 2nd layer of computing in the metaverse. It is sandwiched between the cloud computing layer of metaverse and edge computing layer of metaverse. In layman’s world the work of fog computing for metaverse is to lessen or minimize the burden of cloud computing.

Edge computing is computing that is done at or near or edge of the source of the data being generated. Edge computing basically connects edge devices such input devices, sensors, IoT devices, etc. It is the most essential layer among the 3 layers of computing in the metaverse.

Data is transferred from edge devices to the cloud computing layer. If unnecessary data is transferred anytime, it will burden the cloud computing layer. Here fog computing layers come to play to lessen the burden of cloud layer.

Cloud computing [31,32] servers process the data and transmit it to the fog node. The results of the analysis confirm that the proposed system is suitable. Sensors and IoT devices generate large volumes of data that must be overcome. As well as the priority of usage and the required bandwidth for transmission [33]. By offloading data processing and storage to edge servers, network overhead and energy consumption are reduced. Based on simulation results, the proposed framework provides lower latency and reduces overall energy consumption.

### III. CHALLENGES IN METAVERSE

In immersive technology, the physical world is merged with a digital or simulated reality to create distinct experiences based on the neuroscience of the human brain. In addition to augmented reality (AR) and virtual reality (VR) [25], immersive technologies are also commonly used in extended reality (XR), mixed reality (MR), holography, telepresence, digital twins, and drone flight from a first-person perspective (FPV). As a consequence of the high cost and high demand for medical machinery, training and education it is expensive for students, trainees, and engineers, which in turn increases diagnosis fees for patients. The root cause behind creation



of a digital twin of a medical module, device, or even a whole diagnosis system is an innovative, low-cost way to train.

Through the use of virtual reality or immersive web, some specific scenarios can be recreated in which a patient's clinical condition deteriorates over time. Symptoms can be described with clinical data and treatment plans can be requested based on the diagnosis. This technology can also be used for learning procedures, performing surgery, simulating emergency scenarios, managing pain, and performing physical therapy.

#### IV. METAVERSE TECHNOLOGIES IN SMART HEALTHCARE

Smart Healthcare refers to the technology of enabling innovators to create platforms that can seamlessly and securely run across the healthcare system. Introduction of metaverse in smart healthcare system can lead to solve multiple problems. For instance, patients will be benefitted from the advanced surgical procedures and enhanced health care through the Metaverse. Such complex surgeries are already been tested and implemented through advanced technologies such as Augmented Reality (AR) and robotics. This section provides a brief overview of the technologies that are currently being considered for implementing medical domain metaverses.

##### A. Artificial Intelligence (AI) Based

Due to the rise of artificial intelligence (AI), the industry has been able to innovate and create new opportunities. A variety of medical fields have been benefited from the use of artificial intelligence [21,22] techniques, including neurology, cardiology, nephrology etc. Metaverse coexists with Artificial Intelligence [34], as the major technologies used in Metaverse has been generated with the help of AI. Although combining artificial intelligence with the Metaverse, the current framework will be strengthened further. The 3D immersive experience as well as the built-in services of the virtual worlds [35] will be enhanced. As a result, the metaverse ecosystem and its services will also improve.

Medical devices, healthcare operations, and big data are being used to improve efficacy, reduce costs, and improve quality by using XR, big data, and artificial intelligence. These technologies also help in expanding access to medical care by applying revolutionary

techniques in software and hardware. Using these technologies in Metaverse, patients' medical issues and medical data can be shared with their doctors to facilitate immersive learning, understanding, and sharing. In the Metaverse, doctors can obtain high-quality 3D images and scans of their patients through the use of artificial intelligence (AI). The use of artificial intelligence in metaverse can assist doctors in prioritizing critical patients, minimizing potential errors associated with the analysis of electronic health records (EHR), and creating more accurate diagnoses. It's quite difficult for doctors to remain updated on medical advances and provide patients with high-quality, patient-centered care. A collaboration between the Metaverse and Artificial Intelligence [3, 4] can solve this problem by facilitating the discovery of new drugs, the prediction of diseases, and the response to emergencies. In addition to privacy and ethical concerns, creating an AI-enabled Metaverse may result in medical errors that caused doctors to mislead patients.

##### B. Internet of Things (IoT) based

Currently, billions of devices are connected to the Internet and exchange data [15,16] through the Internet of Things (IoT). Sensors, actuators [18] and communication capabilities enable these devices to share data in real-time without requiring human supervision [5]. The IoT-enabled metaverse is most commonly used in the healthcare industry for remote patient monitoring. Even if patients are not physically present in a hospital or clinic, the Internet of Things can collect vital health metrics and display them in the Metaverse's 3D environment. Therefore, health professionals and vital health information will no longer need to travel for patient's care [6]. It also gets rid of the complex procedures that would be impossible with human hands alone. IoT and Metaverse collaboration helps to manage chronic diseases, improving sleep patterns, replenishing medications, alerting patients etc. during health emergencies. In real-time, non-compliance with data protocols and standards will threaten data security and privacy in IoT-enabled Metaverses. Big Data in Metaverse and Healthcare

Big data refers to data with a high volume, velocity, and variety must be viewed as an asset capable of transforming into value. Analyzing big data often poses various challenges [15-17]. Healthcare, industry, education, agriculture, and so on all use big data in a variety of ways. In AI

and machine learning big data is used for different purposes such as sentiment and behavioral analysis [18], predictive support [19], and fraud detection [20,21] etc.

Through the Metaverse, people can interact and explore virtual worlds in a persistent, real-time, and interoperable manner. Big data is gaining rapid momentum and is becoming an increasingly important technology in the Metaverse. Traditional data analytics tools cannot handle the Metaverse's structured, semi-structured, and unstructured data formats. The Metaverse requires real-time decisions and foresight to make accurate predictions. Big data helps to fulfill all these needs. Metaverse and its underlying mechanisms generate enormous amounts of data which are handled by big data tools.

By using big data tools, healthcare can create digital simulations of patients through the metaverse. It will allow interesting patterns to be discovered by creating digital simulations of patients [22]. Metaverse driven Healthcare can predict accurately the outcome or effect of any medicine or treatment. There are various applications in different domains where big data technologies are combined with the Metaverse. Despite the fact that big data-enabled Metaverse research remains in its infancy, such research will become increasingly crucial as big data allows the Metaverse to generate enormous amounts of A variety of formats for real-time data in an efficient manner.

## V. APPLICATION OF METAVERSE IN HEALTHCARE

Various enabling technologies of the Metaverse will be utilized in a comprehensive healthcare scenario to generate results and make decisions. From research to physical examinations to diagnoses to insurance, the Metaverse has numerous applications in medicine (as shown in Fig.2). By guiding patients through movement and exercises, virtual physiotherapy could assist rehabilitation patients. A comprehensive healthcare application of the Metaverse is graphically represented in Fig.2 and discussed in this section.

### A. *Diagnosis*

Symptoms are used to diagnose a patient's medical condition. By utilizing advanced technologies such as AR and VR-enabled MIIoT models, extended digital twins, blockchain, 5G, etc., the Metaverse contributes significantly to

the efficient diagnosis of medical conditions. Furthermore, the Metaverse has the potential to replace the existing medical IoT by improving human-computer interaction, integrating the real world and virtual world, and interconnecting them. Internet of Things can facilitate holographic construction, emulation, the interaction between the real and virtual worlds, and integration in healthcare, simplifying complex problems encountered there. In the Metaverse, medical professionals can make intelligent diagnoses based on the expertise of Virtual and real-world experts. This allows them to provide quality healthcare and diagnosis. Medical professionals can deliver quality healthcare and diagnose patients virtually in any location by communicating with them in a virtual world. Blockchain technology and distributed ledger technology are being integrated into the Metaverse, health-related digital assets can be stored, exchanged, and programmed efficiently across multiple platforms, allowing for a more precise diagnosis of health conditions with the assistance of data. Utilizing the Metaverse for diagnosis will greatly assist in improving the overall quality of all other phases of care. This is because diagnosis determines the type of treatment and medications to be administered.

### B. *Patient Monitoring*

Metaverse technology, particularly in the area of patient monitoring, will reap amazing benefits due to the convergence of telepresence, digital twinning, and blockchain technology. In the event of a critical situation, these test dummies of patients can be utilized in order to determine the response to surgery or medicine well ahead of its administration to the patient. In order to store and transfer medical data securely and to ensure that it is not compromised or put at danger, blockchain technologies are used because it is the most sensitive and significant type of data. By combining these technologies into one, the Metaverse offers a solution. By offering medical advice followed by a voice conversation or video contact with the patient, COVID-19 has forced medical professionals to consider providing high-quality healthcare even when it is provided remotely [9, 10]. However, with the scientific development of the Metaverse, the healthcare industry will greatly profit from the ability to create virtual worlds wherever is necessary and deliver treatments to the poor even when they are thousands of miles far. This applies to interactions between patients and

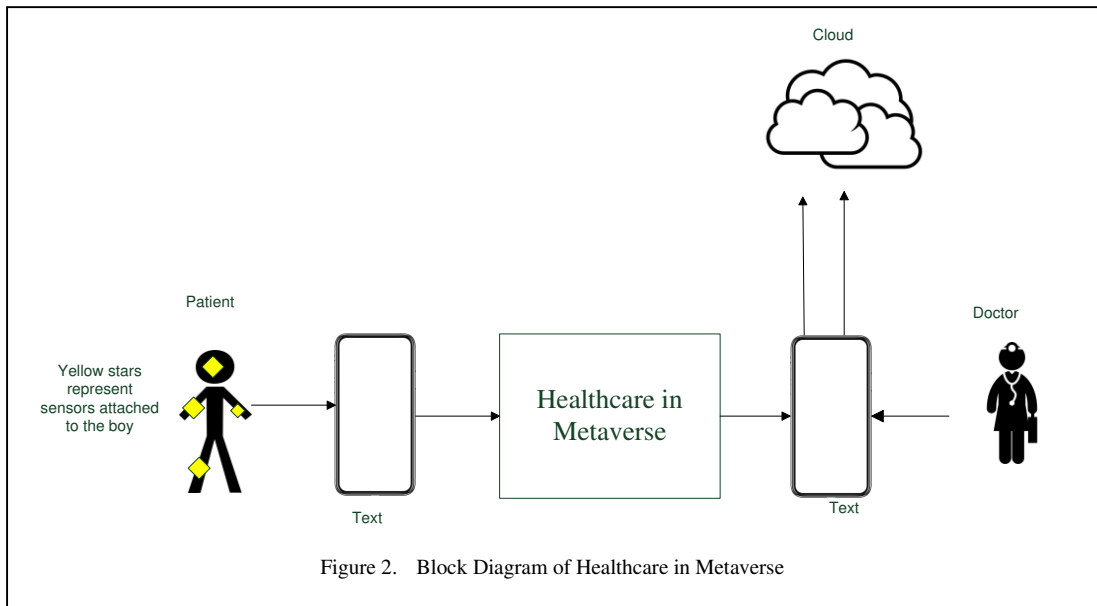

Figure 2. Block Diagram of Healthcare in Metaverse

family members as well as interactions between healthcare professionals and patients.

### C. Surgeries

A crucial piece of medical technology, particularly in surgery, is the metaverse. Currently, surgeons simulate actual surgical procedures using instruments like VR headsets and haptic gloves, which improves readiness and optimal performance in the operating room.

Surgeon can perform operations more easily by using augmented reality to provide them with easy access to data. By projecting 3D virtual representations onto the patient's body, augmented reality can give surgeons quick, simple, hands-free access to patient data. The authors of [12] offer a design for an AR-based solution intended for maxillofacial bone surgery. The AR system consists of a head-mounted wearable gadget that records a person's facial features and makes maxillofacial bone surgery easier. By overlaying the patient details, the product design enables practitioners to create a virtual plan. The authors of [13] explain how spine surgery is accelerated by Metaverse technologies. Minimally invasive spine surgery (MISS) has been adapted by spine surgeons for the past 20 year, which has a high radiation exposure rate. The digital change in spine surgery is being accelerated by a lack of navigational cues and indirect visualization. Only 2D flat monitors are capable of displaying the 3D reconstructed pictures used in spine surgery. Digital transformation in spine surgery

is supported by 3D hologram viewing technologies with advanced spatial imagination. IoMT wearable sensors are used to collect patient data and make patient monitoring easier. The patients, doctors, and students will profit from the use of these Metaverse enabling technologies in the field of healthcare systems. The Immersive Touch Aneurysm Clipping Simulator is a simulation of aneurysm clipping that the creators of [14] have created (ITACS).

### D. Therapy

Medical therapeutics is the branch of medicine that deals with treating diseases. A digital therapeutic is a class of digital medicine that provides evidence-based therapeutic interventions. A review of past trends and prospects in digital therapeutics is presented in [24]. Medical Theranostics combines therapeutics and diagnostics. The Metaverse has the potential to make a significant impact on therapeutics and theranostics because of its underlying technologies. Patients can perform physical exercises in the Metaverse to improve their physical well-being. The use of digital therapeutics eliminates the need to administer drugs to patients, making it extremely useful as medically speaking. Computer vision systems are one example of such technologies that is capable of processing, analyzing, visualizing, and interpreting images and videos. Through the integration of technologies such as augmented reality, virtual reality, emergency room, blockchain, artificial intelligence, and computer vision, the Metaverse represents the future of

medicine. An electronic health record [21] (EHR) can be used to create a digital twin of a patient, from which a 3D simulation can be created. As a result, EHRs play an important role in the field of healthcare.

## VI. CONCLUSIONS

Over the years, the healthcare sector has introduced a number of technological advancements. Healthcare organizations should consider promoting the provision of a safer and more secure environment for outpatient treatment. Although Metaverse in healthcare will have risk as there can be deepfakes spoofing attacks, data injection attacks etc. Since COVID-19 has exceeded expectations, telemedicine has been used more than expected, so optimizing the experience in a virtual environment makes sense. In order to maintain privacy and security, of health data in a virtual platform is important, its implementation also poses concerns. This paper provides a brief overview of how metaverse will have an impact on smart healthcare. Through this paper, we tried to present various artificial intelligence approaches within healthcare. In future, with the inclusion of extended reality, metaverse will improve the smart healthcare industries.

## REFERENCES

- [1] <https://www.forbes.com/sites/bernardmarr/2022/02/23/the-amazing-possibilities-of-healthcare-in-the-metaverse/?sh=5076705b9e5c>
- [2] Mejia, J. M. R., & Rawat, D. B. (2022). Recent Advances in A Medical Domain Metaverse: Status, challenges, and perspective. In *2022 Thirteenth International Conference on Ubiquitous and Future Networks (ICUFN)* (pp. 357-362).
- [3] Srivastava, G., Jhaveri, R., Bhattacharya, S., Pandya, S., Rajeswari, Reddy, P. & Yenduri, G., Hall, J., Alazab, M., Gadekallu, T. (2022). XAI for Cybersecurity: State of the Art, Challenges, Open Issues and Future Directions, *ACM Comput. Surv.*, 1(1), 1-33.
- [4] Wang, S., Qureshi, M. A., Miralles-Pechuaán, L., Huynh-The, T., R.Gadekallu, T., & Liyanage, M. (2021). Explainable AI for B5G/6G: Technical Aspects, Use Cases, And Research Challenges. *arXiv preprint arXiv:2112.04698*.
- [5] Akbar, A., Kousiouris, G., Pervaiz, H., Sancho, J., Ta-Shma, P., Carrez, F., & Moessner, K. (2018) Real-Time Probabilistic Data Fusion for Large-Scale IoT Applications. *IEEE Access*, 6, 15–27.
- [6] Tun, S. Y. Y., Madanian, S., & Mirza, F. (2021) Internet of Things (Iot) Applications for Elderly Care: A Reflective Review. *Aging Clinical And Experimental Research*, 33(4), 855–867.
- [7] Dong, P., Ning, Z., Obaidat, M. S., Jiang, X., Guo, Y., Hu, X., Hu, B., & Sadoun. B. (2020). Edge Computing Based Healthcare Systems: Enabling Decentralized Health Monitoring in Internet of Medical Things. *IEEE Network*, 34(5):254–261.
- [8] Tunc, M. A., Gures, E., & Shaya, I. (2021). A Survey On IoT Smart Healthcare: Emerging Technologies, Applications, Challenges and Future Trends. *arXiv preprint arXiv:2109.02042*.
- [9] Taiwo, O. & Ezugwu, A. E. (2020) Smart Healthcare Support for Remote Patient Monitoring During Covid-19 Quarantine. *Informatics in Medicine Unlocked*, 20, 410-428.
- [10] Jnr, B. A. (2020). Use of Telemedicine and Virtual Care for Remote Treatment in Response to Covid-19 Pandemic. *Journal of Medical Systems*, 44(7), 1–9.
- [11] Wright J. H. & Caudill, R. (2020) Remote Treatment Delivery in Response to the Covid-19 Pandemic. *Psychother Psychosom.*, 89(3), 130-132.
- [12] Qureshi, H. N., Manalastas, M., Zaidi, S. M. A., Imran, A., & Al Kalaa, M. O. (2021) Service Level Agreements for 5G and Beyond: Overview, Challenges and Enablers of 5G-Healthcare Systems. *IEEE Access*, 9, 1044-1061.
- [13] Morimoto T, Kobayashi T, Hirata H, Otani K, Sugimoto M, Tsukamoto M, Yoshihara T, Ueno M, & Mawatari M. XR (2022). Extended Reality: Virtual Reality, Augmented Reality, Mixed Reality Technology in Spine Medicine: Status Quo and Quo Vadis. *Journal of Clinical Medicine.*; 11(2), 470.
- [14] Alaraj, Ali; Luciano, Cristian J.; Bailey, Daniel P.; Elsenousi, Abdussalam; Roitberg, Ben Z.; Bernardo, Antonio; Banerjee, P. Pat; Charbel, & Fady T. (2015). *Virtual Reality Cerebral Aneurysm Clipping Simulation with Real-Time Haptic Feedback. Neurosurgery*, 11(1), 52-58.
- [15] Kamal, M. S., Chowdhury, L., Dey, N., Fong, S. J., & Santosh, K. (2021) Explainable AI to Analyze Outcomes of Spike Neural Network in Covid-19 Chest X-rays. *2021 IEEE International Conference on Systems, Man, and Cybernetics (SMC)* (pp. 3408-3415).
- [16] Khosravy, M., Gupta, N., Dey, N., & Pablo M. G. (2021). Smart green ocean underwater IoT network by ICA-based acoustic blind MIMO OFDM transceiver. *Earth Sci Inform* 14, 1073–1081.
- [17] Kamal, Md. S., Chowdhury, L., Dey, N., Fong, S.J., & Santosh, K. C. (2021). Explainable AI to Analyze Outcomes of Spike Neural Network in Covid-19 Chest X-rays. *SMC 2021*: 3408-3415.
- [18] Bhadani, A. K., & Jothimani, D. (2016). Big Data: Challenges, Opportunities, and Realities. In M. Singh, D. G. (Ed.), *Effective Big Data Management and Opportunities for Implementation*, 1-24.
- [19] Zicari, R.V. (2014) Big Data: Challenges and Opportunities. *Big Data Computing*, 564, 103-107.
- [20] Victor, N., Lopez, D., & Abawajy, J. H. (2016). Privacy models for big data: a survey. *International Journal of Big Data Intelligence*, 3(1), 61-75.
- [21] Singh, A., Ranjan, J., & Mittal, M. (2018) Big Data and Behavior Analytics in Marketing. In *Handbook of E-Business Security* (pp. 225–242). Auerbach Publications.
- [22] Junqué de Fortuny, E., Martens, D., & Provost. F. (2013). Predictive Modeling with Big Data: Is Bigger Really Better. *Big Data*, 1(4), 215–226.

- [23] Tang, J., & Karim, K. E. (2018). Financial Fraud Detection and Big Data Analytics – Implications on Auditors’ Use of Fraud Brainstorming Session. *Managerial Auditing Journal*, 1767-1776.
- [24] Gupta, N., Khosravy, M., Gupta, S., Dey, N., & Crespo, R.G. (2022). Lightweight Artificial Intelligence Technology for Health Diagnosis of Agriculture Vehicles: Parallel Evolving Artificial Neural Networks by Genetic Algorithm. *Int J Parallel Prog*, 50, 1–26.
- [25] Gupta, N., Khosravy, M., Patel, N., Dey, N., & Crespo, R. G. (2022). Lightweight Computational Intelligence for IoT Health Monitoring of Off-Road Vehicles: Enhanced Selection Log-Scaled Mutation GA Structured ANN. *IEEE Transactions on Industrial Informatics*, 18(1), 611-619.
- [26] Herland, M., Khoshgoftaar, T. M., & Bauder, R. A. (2018). Big Data Fraud Detection Using Multiple Medicare Data Sources, *Journal of Big Data*, 5(1), 1–21.
- [27] Karatas, M., Eriskin, L., Deveci, M., Pamucar, D., & Garg, H. (2022). Big Data for Healthcare Industry 4.0: Applications, Challenges and Future Perspectives. *Expert Systems with Applications*, 912-1016.
- [28] Plechatá, A., Makransky, G., & Böhm, R. (2022). Can Extended Reality in The Metaverse Revolutionize Health Communication. *NPJ digital medicine*, 5(1): 1-4.
- [29] Burrone, V., & Graham, L. (2020). Digital Therapeutics Past Trends and Future Prospects. *Digital Technologies*, 32, 1-8.
- [30] Kim, D. H., Go, Y. G., & Choi, S. M. (2020). An Aerial Mixed-Reality Environment for First-Person-View Drone Flying. *Applied Sciences*, 10(16), 5436.
- [31] Mukherjee, A., Mukherjee, P., De, D., & Dey, N. (2021). Qos-Aware 6G-Enabled Ultra Low Latency Edge-Assisted Internet of Drone Things for Real-Time Stride Analysis. *Computers & Electrical Engineering*, 95, 107438.
- [32] Sarwar, M. G., Kamal, M. S., & Dey, N. (2019). Internet of Things and Its Impacts in Computing Intelligence: A Comprehensive Review – IoT Application for Big Data. In N. Dey, & S. Tamane (Ed.), *Big Data Analytics for Smart and Connected Cities*, 103-136.
- [33] Das, D., Maji, P., Dey, G., & Dey, N. (2014). Ethical E-Health: A Possibility of the Future or a Distant Dream?. *International Journal of E-Health and Medical Communications*, 5, 17-28.
- [34] Biswas, A., Dutta, S., Dey, Nilanjan & Azar, Ahmad. (2015). A Kinect-less Augmented Reality Approach to Real-time Tag-less Virtual Trial Room Simulation. *International Journal of Service Science, Management, Engineering, and Technology*, 5, 16-23.
- [35] Sodhro, A.H., Zahid, N. (2021). AI-Enabled Framework for Fog Computing Driven E-Healthcare Applications. *Sensors*, 21(23), 8039-8044.

# The Influence of Mobile Phones on Children and Youth - General Overview

Nenad Perić<sup>1</sup>, Olja Arsenijević<sup>2</sup>

<sup>1,2</sup>Institute for Serbian Culture Priština-Leposavić, Leposavić, Serbia

<sup>1</sup>nesaperic777@gmail.com, <sup>2</sup>arsenijevicolja@gmail.com

**Abstract**—The impact of technology on society and the individuals has increased rapidly in the last thirty years and has reached the stage to shape both society and the individual. The paper studies the impact that mobile phones exert as mobile phone devices and all the technological extensions it has gained. It focuses on the impact it has on children and young people as groups that, unlike previous generations, grew up or were born with this technology. The impact is produced in the social sense and at the level of the individual, in social, cultural, educational and all other impacts that arise from the above.

**Keywords** – mobile phones, children, youth, education, violence

## I. INTRODUCTION

In the last two decades, the digital revolution has unstoppably conquered the world, creating new generations that are significantly different from the previous ones. Young people and children, born at the end of the last century towards present, consider a mobile (smart) phone as part of their living space. The mobile phone has become an indisputable source of entertainment and information in terms of individual and collective games, a medium for music, movies, for creating photos and videos (and also uploading them to social networks), video chats, surfing the Internet and more in addition to its basic functions-conversations and text messages. That is why they spend a large part of their time with a mobile phone in hand. These are the generations to whom the Internet, computers and mobile phones were given at birth, and they grow up with them, almost unaware of the world in which these gadgets did

not exist. Their habits are different and structured in terms of information technology. Dependence on these gadgets is increasing, and as this drastic change happened in a short period of time, part of the older users (i.e. parents of children and youth) remained insufficiently informed about the advanced capabilities of mobile phones or it is difficult for them to follow the rhythm and content of the novelties.

The issue of the consequences of using mobile phones has become a new and very dynamic area of research, so more and more is being written about the consequences of using these innovations on the intellectual, emotional and social development of children and youth. However, the opinions that can be found in the professional literature are often polarized. Many believe that mobile phones can lead to significant successes in the education of children, as well as being a useful tool to establish communication between young people from different cultural and linguistic backgrounds. Contrary to them are those who express the fear that the use of mobile phones can lead to a weaker mastery of basic operations (reading, writing and calculation), and there is also a fear that children and young people who spend too much time with a mobile phone can become isolated and end up in a situation where the mobile phone is their “best friend”; therefore, they might be deprived of the social relations that are necessary for their normal development in the social sense. “Namely, the media can have both positive and negative impact on different areas of children’s development. Whether the negative effects will occur, depends on numerous factors and the way

the media are used” [1]. The same goes for the mobile phones.

## II. PSYCHO-PHYSICAL DEVELOPMENT OF CHILDREN AND YOUTH AND MOBILE PHONES

“In developed and moderately developed countries (such as Serbia) a great deal less children spend the dominant part of their free time outside, playing with peers, while an increasing number of children spends hours with their mobile phones, in the so-called virtual world, with contents and programs that are not usually adapted to their age and needs” [1]. This is also related to a growing concern of the public (especially professional one) about possible harmful effects of electromagnetic radiation that the mobile users are exposed to, with children being the most vulnerable since they are in the stage of physical development [2,3].

Just like a television program, the mobile phone has the power to hold the user's attention often much longer than he would really like, and that is useful for him. This is true for adults, but even more so for children. Because, if adults, despite their greater level of development and experience, are not immune to the “charm” of mobile-smartphones, why should we assume that children are able to resist it and focus on the advantages of using them... Children mostly choose to communicate with their peers, watch short video content and play video games. In this way, the media and their channels increasingly become the main agent of socialization, from which they displace school, family, and even peers from school, thus influencing the entire formation of values and behavioral styles of the young generation. With the Internet (which children and young people primarily follow using mobile phones), concern for others “dies” - the quality of dialogue between peers is drastically reduced, the boundaries of time are lost because the Internet is available (almost) everywhere and is present non-stop. With Internet one has no limits regarding the amount of information and manipulations. Practice and experience show that socially and emotionally insecure children are more prone to media addiction. In contrast, communicative youngsters put the media on the back burner and spend more time interacting with people [4]. Thus, this condition produces Internet addicts, which modern medicine has long recognized as a disease... This gradually leads to “digital narcissism” [5].

The study of one Internet company, which included 2,200 mothers of children aged two to five, namely from the United States, Canada, Japan, Australia, New Zealand and some European countries, has provided interesting but also disturbing results, although one cannot regard these as being too surprising. Almost 19% of these children know how to use the applications on smart phones, while only 9% of them can tie shoelaces, and only 20% can swim. Thus, tested children cope better with computer games and managing smartphones than independently tying shoelaces or entering the pool without any swimming aids [6].

Despite concerns about the health effects of long-term exposure to RF radiation, the popularity of the use of wireless devices among young children is growing rapidly, even in case of very young children. Nineteen per cent of children aged two to five would be more likely to use a smartphone than to spend time doing some other activities. Almost the same number of children aged two to three (17%) use smart applications, as well as children aged four to five (21%). One quarter of all children aged two to five know how to make a call using mobile phones. Many phones are specially designed for small children, some even with applications for pre-school children [2].

Define abbreviations and acronyms the first time they are used in the text, even after they have been defined in the abstract. Do not use abbreviations in the title or heads unless they are unavoidable.

Many researches and studies emphasize that children should not use mobile phones at all, because the thin bones of the skull, skin and subcutaneous tissue do not present any obstacle to the penetration of electromagnetic radiation [7]. But smart phones have become an integral part of school activities. A concern about the health risks for children from mobile phone radiation has led to the prohibition of the use of mobile phones in schools. For instance, the Israeli Ministry of Education decided to ban mobile phones during the school day in 2016. In France, the policy came into effect during the beginning of the 2018–2019 school year and impacted students over 15. In 2019, four states in Australia banned smartphones for students up to 18 years. Also, mobile phones in schools are banned in Greece, Iran, Turkmenistan and Malaysia. Governments pursue two main goals with this type of policy intervention: improving

academic performance and reducing bullying, which are precisely the impacts that we address in this paper [8]. According to the current Law on the Basics of the Education System, in Serbia, the use of a mobile phone in class is considered a serious violation of the student's obligations. The same Law prescribes the autonomy of the institution, which includes autonomy in adopting the statute, development plan, program, annual work plan, rules of conduct in the institution, the use of mobile and other electronic devices for educational purposes. In practice, a trend can be observed that Serbian schools are beginning to ban the use of mobile phones during classes.

### III. USING MOBILE PHONES FOR EDUCATIONAL PURPOSES

“Increased interest in mobile devices and their use for teaching and research can be attributed to a number of factors: rapid expansion and advancement of wireless broadband networks, exceptional growth in of power and capacity of each next generation of mobile and PDA devices, but also the fact that these appliances are deeply embedded into daily life” [1].

The design of educational applications for mobile phones and PDA devices has led to the fact that they are increasingly being used among children of all ages and at all levels of education. Due to this, the term m-learning-mobile learning originated. Teachers and administrators use these devices and applications to record class attendance, send pupils and students teaching material, homework, exams and a great deal of information related to school and extracurricular activities. Mobile learning connects formal practice (e.g. class attendance, participation in workshops and etc.) with the informal or so-called situational learning (e.g. while the student rides the bus, subway or train or while queuing for healthy, control) and mobile devices are used as translators, encyclopedias and digital libraries. It is very important to note that this model does not necessarily imply Internet connection in order to learn because downloaded materials or information can be used in off-line mode [1].

One of the commonly used options of m-learning are language courses. For example, the Ectaco Company in the USA offers linguistic games for mobile phones, as well as software for dictionaries and books with certain phrases in order to improve the language skills of the users. The company has released seven generations of dictionaries so far, as well as solutions for

learning languages and translation applications for forty-five languages, including Serbian [9]. “On the other hand, an important lack of m-learning lies in the way it is used, which is mostly spontaneously organized, and thus this kind of learning profile usually takes place in a shorter period of time and with frequent interruptions. Furthermore, interruptions are caused by one inescapable, but very important factor. This is the basic function of mobile phones and the way they are used-the use them to a great extent for different forms of communication (in addition to traditional calls and messages there are extremely widespread services such as Viber, WhatsApp, and the social networks Tic-Toc, Instagram, YouTube, etc.), and plenty of notice and information by which all of these overload their customers and this interferes with the work because it requires a kind of self-control which is not peculiar to most young people” [1].

The options and technical possibilities for using mobile phones in teaching and education are expanding rapidly and educational systems would have to use the medium and tool-mobile phone intensively and in creative ways, so that the overall effectiveness of learning could be increased. Also, society that is based on knowledge and at the same time regarded as the society of lifelong learning, implies that education in general should be viewed in a broader context, i.e., through different educational policy, methods and techniques, with e-learning and m-learning being those that stand out today [10].

### IV. VIOLENCE AND MOBILE PHONES

More and more often, we are witnessing films recorded with mobile phones by children or young people whose goals are to ridicule or blackmail their peers. Furthermore, one can freely talk about an epidemic of the above, although schools and the school system often try to cover it up, among other things because it is difficult to find a solution for this because it is a sociological phenomenon. Considering that every child has his own mobile phone, and only a small number are in controlled conditions, the danger of violence that uses a mobile phone as a technical tool is increasing [11]. The element of abuse includes harm as an outcome of violent behavior, which is often more difficult to recognize in the virtual world [12]. Namely, young people who behave violently do not see the person they are harming, nor the consequences of such behavior, thus maintaining



an emotional distance and showing a lack of empathy [13]. The fact that millions of videos made by children aged 12 to 16 are removed from the Internet every year is worrying. The results showed that sending instant messages is associated with participation in electronic violence, while greater use of social networks is associated with more frequent experiences of violence. In Serbia, for instance, every third pupil has experienced some sort of violence through Internet in last twelve months, while cyberbullying has experienced 16% of them [14].

Since cruelty on the Internet can be intensified by the distance between the perpetrator and the victim, the concept of violence is changing. Nowadays, it is easier to become a target of peer violence. It cannot be said that it is because of mobile phones, but because of the radical changes in society that have been registered since the end of the last century. Nevertheless, the fact is that mobile phones have significantly facilitated the aforementioned. Children have access to each other twenty-four hours a day and can commit violence at any time of the day or night. The effect is further enhanced by the fact that children use mobile phones to surf the Internet much more than they use standard and laptop computers, so it is more difficult for parents to monitor and control them in this regard. Continuous professional development of teachers is necessary, which would provide them with an insight into the nature of the so-called cyberbullying and ways to prevent and curb it, because the role of the school has proven to be successful in dealing with school violence. Therefore, every school must have its own plan of action that is adapted to the specific conditions of that school, and it cannot be completely adopted from another school. The process or path of creating your own way of fighting violence is as important as the result itself. "The school must set clear rules that do not allow violence and define the consequences if such behavior occurs." It is necessary that these rules are applied daily, because that is the only way violence will stop or at least be limited [15]. Also, parents should be introduced to the methods of cyberbullying and how to properly position themselves in case of the same.

## V. CONCLUSION

Since the beginning of the new millennium, digital (r)evolution has created new generations, the generations whose life is considerably

different from the previous ones from the very start. These generations are distinguished by knowledge and widespread use of media, digital technology and information. It is quite natural to them to receive much more data than previous generations, to learn what they choose by themselves, to communicate simultaneously in a number of ways [15].

Today's children perform better in the virtual world than in the real world. On the other hand, they know little or nothing about some ordinary, everyday things, because they spend a whole lot of time with a mobile phone or in front of a screen (computer or television), with much less physical activity than is recommended. All of this happens in the period of life when it is especially important to be physically active as much as possible. Today's children are adept at understanding technological achievements, but have increasingly poor social relationships with their peers. However, schools and school systems that do not adapt to the fact that a mobile phone is an "extension" of the average student will not be able to progress as much as those that adopt the use of mobile phones in their teaching processes. The former is more likely to be condemned to declination.

Furthermore, the risks of excessive Internet surfing or playing video games on a mobile phone begin when selectivity in the choice of content is lost. It goes without saying that it is not possible, nor would it be desirable, to isolate children from mobile phones, but it should not be allowed to be their dominant way of spending time. We live in an imperfect world where children are in greater danger than ever before, because in addition to the dangers in the real world, there are also dangers in the virtual world. Furthermore, as young people with a higher degree of internet addiction are more likely to participate in electronic violence (whether they experience it or commit it), it is important to emphasize the education of both young people and their parents, because mobile phone addiction and electronic violence are the result of a lack of control in the virtual world.

Certainly, the media literacy is one of the best ways to prevent misuse of the mass media and to improve the efficiency of their strengths in order of educate and up bring youth and the youngest. To make someone media literacy would mean to enable one to understand and use popular as well as educational and scientific contents, to be able to express his or her ideas in the form of media,

to be able to communicate through channels of mass media in order to acquire knowledge and notify his or her own attitudes [16].

“Education for the media, i.e. the media literacy is a prerequisite for critical reading and media use. It is necessary to be media literate in order to use the media and global information networks, while on the other hand the media and networks provide the opportunity to gain media literacy” [1]. According to the European Framework of Key Competences, digital competence has the status of one of the eight key competences in education. It is defined as the ability to use technology critically and safely at work, in leisure and communication. “The government primarily has the responsibility for this by conducting certain educational and cultural policy which, among other things, increases the level of digital literacy of all involved participants in the analysis of this study: the school, parents and children, as well as the society in its broadest sense. Finally, all relevant documents of educational policies in the world emphasize the importance of the development of media and technological literacy” [1].

#### REFERENCES

- [1] Perić, N. (2017). *The impact and implementation of digital media on children's upbringing and education*. CRC in Digital Spaces – Challenges and Expectations (ed. Ljiljana Bulatović), 143-164.
- [2] *Cell Phones: technology, exposures, health effects*, Available at : [http://www.ehhi.org/reports/cellphones/cell\\_phone\\_report\\_EHHi\\_Feb2012.pdf](http://www.ehhi.org/reports/cellphones/cell_phone_report_EHHi_Feb2012.pdf)
- [3] Mićević-Karanović, J., Mesaroš-Živkov, A., Pavlov Srblava, V., Brkljač, T. (2020). Rizični uticaji digitalnih medija na psihofizički razvoj dece predškolskog uzrasta. *Sinteze*, 18, 33-53.
- [4] Beždanov-Gostimir, S., Radinović, K. (2000). *Dete sa tri lista: porodica, škola, mediji*. Radnički univerzitet Đuro Salaj.
- [5] Keen, A. (2007). *The Cult of the Amateur: How Today's Internet Is Killing Our Culture is a Currency*
- [6] <http://www.vesti.rs/Zivot/Sta-sve-ne-znajusavremeni-klinci.html>
- [7] Stanković, V., Jovanović, D., Krstić, D., Marković, NV., Cvetković, N. (2016). Mobile phones and children. *Safety engineering - inženjerstvo zaštite*, 6(1), 47-52.
- [8] Beneito, P. Vicente-Chirivella, Ó. (2022). Banning mobile phones in schools: evidence from regional-level policies in Spain. *Applied Economic Analysis*, 30 (90), 153-175.
- [9] <http://www.ectaco.com/company/mediabg/>
- [10] Vasiljević-Blagojević, M., Terzić-Marković, D., Perić, N. (2014). Uloga i uticaj obrazovanja na društveni i ekonomski razvoj pojedinca i zemlje. *Zbornik radova Međunarodne naučne konferencije Metodički dani* (pp. 108-114).
- [11] Jevtić, R. (2020). Digitalno nasilje i uloga različitih faktora u njegovoj prevenciji i sankciji u Srbiji. *Zbornik radova Pedagoškog fakulteta*, Užice, 22, 195-212.
- [12] Vandebosch, H., Van Cleemput, K. (2008). Defining cyberbullying: A qualitative research into the perceptions of youngsters. *Cyberpsychology & Behavior*, 11(4), 499–503.
- [13] Ovejero, A., Yubero, S., Larrañaga, E., Moral, M. V. (2015). Cyberbullying: Definitions and facts from a psychosocial perspective. In *Cyberbullying across the globe* (Ed. Navarro, S. Yubero i E. Larrañaga), 1–31.
- [14] Buljan-Flander, G. (2003). *Hrabri telefon: Dijete na internetu, brošura za roditelje*. Poliklinika za zaštitu djece grada Zagreba.
- [15] Veen, W., Vrakking, B., (2006). *Homo Zappiens: Growing up in a digital age*. Network Continuum Education.
- [16] Zindović-Vukadinović, G., (1997). Medijska pismenost: teorija i praksa, *Zbornik Instituta za pedagoška istraživanja*, (29), 244–259.



# Knowledge Management in the Hotel Industry as a Relevant Contribution to the Development of the Tourism Sector

Borislav Kolarić<sup>1</sup>, Jelena Ignjatović<sup>2</sup>, Goran Stojićević<sup>3</sup>, Aleksandra Đorđević<sup>4</sup>

<sup>1,2,3,4</sup>Academy of Applied Studies Šabac, Šabac, Serbia

<sup>1</sup>kayak@mts.rs, <sup>2</sup>jignjatovic985@mail.com, <sup>3</sup>csugoran@mail.com, <sup>4</sup>aleksandradj993@mail.com

**Abstract**—Knowledge is one of important resource in the modern organizational business. By using new knowledge, organizations become more competitive in the context of reducing costs, increasing speed and meeting customer needs. Since the satisfaction of tourism employees depends on many factors, knowledge management (KM) is one of them. Namely, the role of knowledge management in the hotel industry is to provide employees with easy access to modern, specialized knowledge. The success of an establishment depends on providing great experience for guests. With the proper knowledge management framework, employees gain the ability to respond to guests' questions and concerns with quick, accurate information and action. The purpose of the paper is to present the importance of knowledge management in the modern challenges of hospitality business as well as the conditions required for successful implementation. The aim of this paper is to point out the importance of knowledge management in the hotel industry, which will make a relevant contribution to the development of the tourism sector. In addition to the introduction, the paper consists of three parts. The first part of the paper indicates the importance of knowledge management in the hotel industry as a contribution to the development of tourism, the second part of the paper analyzes the characteristics of knowledge management in the hotel industry, while the third presents categories and factors for effective knowledge management in the hotel industry. At the end, the concluding considerations of the author are given.

**Keywords** – knowledge management, hotel industry, development, tourism.

## I. INTRODUCTION

Progress and development of the tourism sector [1,2] rely on its adaptation capacity in terms of responding to economic, social, and technological challenges. The major task of hotels is to promote customer satisfaction, while the major factor on customer satisfaction is quality [3]. Given the intense competition throughout the industry, where customers are constantly looking for the best deals, hotel management and employees face major challenges. Knowledge and understanding of all elements of business, including continuous change in accordance with social changes and changes in customer preferences, is of key importance.

Competitiveness in the global market depends on the organizations ability to capitalize on its intellectual and knowledge-based assets. In this sense, knowledge is recognized as a powerful means of supporting organizations in the tourism industry, in creating an efficient model for achieving competitive advantage and achieving the desired business performance. Hospitality and tourism knowledge is heavily labor dependent, as employees use their knowledge in providing the best experience for customers. Customer satisfaction and loyalty are the most important factors to the success of a hotel. Knowledge management (KM) in hospitality and tourism organizations is imperative, as most employees have direct contact with customers, so organizations want to ensure that employees provide a service that will attract new clients and retain returnees [4]. Therefore, it is

important for employees to have the knowledge about customer preferences and how to provide the best service [5].

Therefore, the aim of this paper is to present the importance of KM in the hotel industry, which has a contribution to the development of the tourism sector. In addition to the introductory considerations, the first part of the paper draws attention to the importance of KM in the hotel industry. The second part of the paper examines the characteristics of knowledge management in the hotel industry, while the third presents categories and factors for effective KM in the hotel industry. At the end, a conclusion is given.

## II. THE IMPORTANCE OF KNOWLEDGE MANAGEMENT IN HOTEL INDUSTRY

In light of the dynamic changes in the global scenario, individual companies and the entire hospitality sector are facing serious problems, related to increasing uncertainty in business, changing customer preferences and shorter life cycle of service products [6]. Tourism is an intensive activity and highly people oriented service, experiencing increasing powerful worldwide competition. Therefore, to improve their performance and ensure a high level of competitiveness, adoption of knowledge management concepts and models is must for organizations in tourism and hospitality sector [7]. Knowledge as a business perspective is much more than information and knowledge sharing in terms of sharing experiences, practices, and procedures is beyond information sharing [8]. An organization's knowledge strategy, in the tourism industry, must link the generation of business value and the development of competitive advantage, assessing knowledge resources, competencies and capacity for successful execution of business processes [7]. Medlik (1990) observed that improving an employee's knowledge about customers preferences and the corresponding service procedures is becoming increasingly important in hotels. When hospitality businesses identify and exploit their organizational knowledge, they should observe enhanced dynamic capabilities and improved business performance [10].

Transformation of knowledge into key competencies and competitive advantage in the tourism and hospitality organizations primarily is influenced with transferring and sharing knowledge within the organization and with

cooperating enterprises [9]. Challenges in the adoption and use of KM approaches in the tourism industry relate to [11]:

- how to identify and collect important, appropriate, accurate and authentic information;
- how to organize and process information;
- how to access, share and use resources, and
- how to recognize knowledge and prior experience to prepare them to assist current decision-making processes.

Development of effective KM system in tourist organization requires an incremental approach in two-step approach to develop and adopt KM. The first step can be used in building awareness of KM throughout the organization, to instruct employees about KM, developing at the same time the technology infrastructure to support KM adoption [12]. During the next step, the establishing of the organisational infrastructure is required to implant KM processes into the organisation's business operations. The technology will enable knowledge sharing, and assist in integrating KM practice into organisation's strategy of human resource management. Knowledge projects are likely to succeed when a sophisticated technology infrastructure is adopted.

IT is used as a medium for knowledge flow, supporting communication and collaborative knowledge seeking, enabling collaborative learning [13]. IT infrastructure includes E-mail, document management, data warehousing, workflow software, decision support system etc. A KM system must be open, distributed, customizable and secure to effectively meet the needs of the organization. After successful fulfilment of these two steps, implemented KM system allows the tourist destination and its related service sector transition into learning destination, where organizational learning is recognized as knowledge acquisition, retention, and retrieval [8].

## III. CHARACTERISTICS OF KM IN THE HOTEL INDUSTRY

Hotels are currently increasingly dependent on their competence to possess internal and external knowledge, making knowledge a critical resource for competitiveness and obtaining competitive advantages for innovation

and differentiation of its competitors [14]. The fundamental knowledge for the provision of the hotel service is based on the internal knowledge of its employees, the cooperation between them and the synergistic complementarity of knowledge [15]. The strategies of management of internal knowledge in the hotel industry are based on the creation, transfer and distribution of intra-organizational knowledge (Fig.1). They have an emphasis on the accumulation and preservation of organizational knowledge, as well as on encouraging the exchange of knowledge between employees [16].

The internal KM, together with the creative processes of the employees have a decisive role in the incremental innovations of the sector, namely in creating experiences beyond the expectations of the clients, trying to anticipate their needs [18]. Hotel managers and staff, due to proximity and direct contact with customers, are more likely to acquire knowledge about them, as knowledge flows are more direct and faster, allowing for more detailed information about their wishes, needs, preferences and market trends [14]. These knowledge flows are a potentiator of the generation of ideas and incremental innovations, since the knowledge and suggestions provided by clients are related to the hotel's current services, practices, tasks or activities [20].

Some of the customer-oriented knowledge acquisition processes are obtained through central information and reservation systems [16]. The systematic inclusion of hotels in strategic cooperation networks, in order to create and transfer knowledge within the tourism sector, is a key factor in the diversification of business and the generation of radical innovative ideas [19]. External social

relations of managers and hotel staff, contacts with different communities outside the company, exposure to different information and perspectives, develop creativity contributing to innovation [19]. In addition, the management of external knowledge, acquired through cooperative networks of companies in this industry, should mitigate the uncertainty of completely uncontrollable events. It must also adapt to external changes, diversifying opportunities, anticipating trends and above all, encouraging the transfer of knowledge through the organizational structure [20].

For an effective transfer of external knowledge, it is necessary for the hotel to have internal structures that allow the dissemination and sharing of this knowledge [20]. Tacit and explicit knowledge also has the dominant role in hospitality service operations . The implicit orientation to the processes illustrates the relevance of tacit knowledge in the hotel industry, which is a dynamic and constantly changing environment [21]. For an effective creation, sharing and use of tacit knowledge, proximity is essential for the development of strong levels of trust and common values, since they require direct and reciprocal interaction [22]. In the hospitality sector, this flow of personal knowledge is carried out through direct communication, meetings between the management team and the rest of the workforce, sharing of emails, training and practical experiences in the work context. This gives trainees the possibility to observe, imitate and test skills and to incorporate routines [23]. When employees have a high level of experience and skills, they tend to increase the efficiency and productivity of other colleagues. On the other hand, hotels can manage their tacit knowledge through the creation of employee profiles or the creation of corporate lists of employees with specifications according to a certain knowledge area [21].

#### IV. RELATIONSHIP KM AND INOVATIONS IN HOTEL INDUSTRY

Through capabilities and the experiences of the individuals of an organization, it increases the capacity to retrieve and promote organizational capitals and innovation performance. Gamble and Blackwell [24] emphasize the organizational management of KM toward continuous knowledge-based innovation, with an emphasis on workgroup and knowledge dissemination. Chiu and

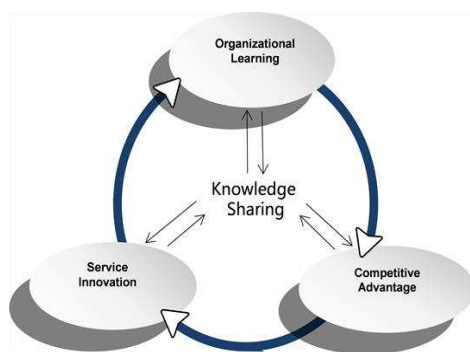

Figure 1. Knowledge sharing [17]

Fogel [25] argue that organizational and managerial practices can have a positive effect on the implementation of an innovative knowledge-driven system and the obtained results might lead to the outstanding results and meeting the interests of the organization. Since application of knowledge would lead to innovation and performance improvement in an organization, then organizations always benefit from KM techniques for development and greater profitability [26]. The KM literature considers innovation as a critical factor for companies in creating value and maintaining a competitive advantage in today's highly complex and dynamic environment [27]. Innovative inventions are highly related to knowledge, expertise, and commitment of employees as key inputs in the value creation process. Therefore, researchers emphasize the central role of KM, especially in creating an internal work environment that supports creativity and innovation [28].

An effective tacit KM strategy is essential for hotels to create innovative products and successfully develop in the ever-changing tourism market [29].

The ability to motivate employees, with a high level of skills, to turn their tacit knowledge about specific tasks into explicit, leads to an increase in knowledge about the hotel organization [29]. Likewise, the possibility of intensive communication with the client, in the hotel industry, strengthens the relevance of the existence of explicit KM for business [21]. A hybrid strategy is recommended for hotels. Some tacit knowledge, i.e. routines embedded in services, can only be transferred through direct personal relationships, while innovation also results from the simultaneity of explicit and tacit KM [21].

#### V. CATEGORIES AND FACTOR FOR EFFECTIVE KM IN HOTEL INDUSTRY

The role of KM in the service industry (which includes hotels) is to provide employees with easy access to up-to-date, specialized knowledge. This is especially important in the hospitality industry, because the success of the establishment depends on the satisfaction of the guests. If employees are slow to provide accurate information or solutions, the guest is less likely to return. A negative online review can also show guest dissatisfaction. Solid KM framework can empower workforce to respond

to guests' questions and issues with prompt, accurate information. Furthermore, insights into customer data and trends can be gained so that fact-based organizational decisions can be made to give the institution an advantage in a highly competitive environment.

Understanding different types of knowledge can help to determine the best KM strategy for your organization. Hospitality industry knowledge generally falls into the following categories [30]:

- **Task-specific knowledge:** This encompasses any knowledge that is required to complete a particular task, including specific procedures, actions, or strategies. For example, a staff member uses task-specific knowledge when following the steps to check in a guest, make a reservation, or answer the phone with a standardized greeting. Generally, this information is included in training materials, like videos or handbooks.
- **Tacit knowledge is less by-the-book.** Rather, it is knowledge that's gained over time through personal experience and usually difficult to articulate. This could include understanding the phrases and mannerisms to use to de-escalate a frustrated guest. While you may have a documented protocol for this type of situation, it's usually only through experience that staff members can expertly finesse these difficult interactions.
- **Customer-related knowledge:** Thanks to technology, hotels and other hospitality-related businesses today have a wealth of insight into customer data. Customer-related knowledge could include historical data (such as frequency and length of stays), demographic data (such as socio-economic status, age, occupation, etc.), and even preferences and behaviors.
- **Network-related knowledge:** In addition to customer data, your company can also gather knowledge about others in your network, such as competitors, vendors, and partners.
- **Market-related knowledge:** Market-related knowledge goes one step

broader than network-related knowledge. Equipped with market-related knowledge, organizations can better understand the market that it is operating within—such as size, population, culture, and habits. This can inform decisions about what products, services, and experiences to offer.

Knowledge in tourism and hospitality industry is substantially labor dependent and employees, knowing guests' preferences, use that knowledge in providing the best service for customers, because guests satisfaction and their loyalty are among key success factors in the tourism business [31]. The successful and effective use of KM in the hotel industry is influenced by many factors such as:

- *Strategy* - In a hotels organization, in creating added value, employees can use their competencies on two ways: externally through relationships with customers, and suppliers, or internally through management, administrative systems, models, and attitudes. Knowledge strategy has to be connected with business strategy [32].
- *The organisational culture* Developing an organisational culture that values knowledge sharing and knowledge creation can assist in the process of transforming individual or tacit knowledge into collective knowledge [7].
- *Knowledge creation* - The effective creation of new knowledge, with a focus on tacit knowledge, depends on strong relationships among the employees in an organization. KM approach has to pay attention especially to tacit knowledge and explore new organizational forms, cultures and incentive packages to advance interpersonal interaction and social relationships [7].
- *Learning and Participation* - Employees can learn participating in communities of knowledge sharing their specific perspectives and practices. Basic instruments of knowledge creation are communication, consideration, debate and negotiation. In that sense, the

organisational culture is expected to provide a climate where learning and knowledge are highly respected [33].

- *Accessible knowledge across the organization* - With a modern knowledge management system, employees will always know where to find information. Knowledge management systems give organizational leaders access to a centralized source of customer insights. Equipped with that knowledge, they can make more informed decisions about how to improve the customer experience.
- *Leadership* - Knowledge can be managed when leaders understand, cultivate and assist in the knowledge creation. Senior management has to enable and support knowledge creation, nurturing, growth and sharing, ensuring the creation platforms and cultures where knowledge can freely emerge [33].

## VI. CONCLUSION

Knowledge can be considered one of the most important tools for effective business in the hotel industry, precisely because KM practices can help develop dynamic capabilities and create competitive advantage. The main goal of KM is to improve organizational capabilities, solve problems and enable innovation. In this way, the business can develop unique dynamic capabilities, so that the company can implement the overall strategy and achieve its goals. Therefore, hotel organizations should take advantage of the unique knowledge they possess. This implies that they should see themselves as knowledge processing companies and their employees and managers as knowledge workers. Hotel management should build an organizational design that enables the creation of new knowledge, knowledge exchange and transfer across functional boundaries. At the same time, knowledge should be frequently checked for errors. Hotel organizations should support the role of knowledge in the success of their departments, ensure that employees understand KM and encourage them to participate in training and learning, as well as to collect and transfer knowledge.



## REFERENCES

- [1] Kisin J., Ignjatovic J., & Vemic-Djurkovic, J. (2022). Corporate restructuring in the economy of tourism sector: a case study of Air Serbia. In V. Bevanda & S. Štetić (Eds.), *6th International Thematic Monograph - Modern Management Tools and Economy of Tourism Sector in Present Era* (pp. 315-331). Association of Economists and Managers of the Balkans and Ohrid, Faculty of Tourism and Hospitality.
- [2] Stojićević, G., Kolarčić, B., Ignjatović, J., Spasojević, S., & Knežević, S. (2022). The influence of bioclimate conditions on the development of tourism on the Zlatibor mountains. In *XI international conference of social and technological development* (pp. 745-757).
- [3] Fallon P., & Schofield P. (2000). Service Quality Measurement and Triadic Interaction. *Journal of Quality Assurance in Hospitality & Tourism*, 1(3), 29-47.
- [4] Medlik, S. (1990). *The Business of Hotels*. (2nd ed.). Oxford: Heinemann. Nightingale, M. (1985).
- [5] Cooper, C. (2006). Knowledge Management and Tourism. *Annals of Tourism Research*, 33(1), 47-64.
- [6] Scott, N., & Laws, E. (2006). Knowledge sharing in tourism and hospitality. *Journal of Quality Assurance in Hospitality & Tourism*, 7(1-2), 1-12.
- [7] Tribe, J., & Liburd, J. J. (2016). The tourism knowledge system. *Annals of Tourism Research*, 57, 44-61.
- [8] Omotayo, F. O. (2015). Knowledge management as an important tool in organisational management: a review of literature. *Library Philosophy and Practice*, 1238.
- [9] Scott, N., & Marzano, G. (2015). Governance of tourism in OECD countries. *Tourism Recreation Research*, 40(2), 181-193.
- [10] Sainaghi, R., Köseoglu, M. A., d'Angella, F., & Tetteh, I. L. (2019). Foundations of hospitality performance measurement research: A co citation approach. *International Journal of Hospitality Management*, 79, 21-40.
- [11] Cooper, C. (2014). Managing tourism knowledge: concepts and approaches. In M. McLeod & R. Vaughan (Eds.), *Knowledge Networks and Tourism*, (pp. 76-93). Routledge.
- [12] Altinay, L., Paraskevas, A., & Jang, S. S. (2015). *Planning Research in Hospitality and Tourism* (2nd ed.). Routledge.
- [13] Tzortzaki, A. M., & Mihiotis, A. (2012). A three dimensional knowledge management framework for hospitality and tourism. *Foresight*, 14(3), 242-259.
- [14] Wilkea, E. P., Costa, B. K., Freire, O. B. D. L., & Ferreira, M. P. (2019). Interorganizational cooperation in tourist destination: Building performance in the hotel industry. *Tourism Management*, 72, 340-351.
- [15] Sigala, M., & Chalkiti, K. (2015). Knowledge management, social media and employee creativity. *International Journal of Hospitality Management*, 45, 44-58.
- [16] Bouncken, R. B. (2002). Knowledge management for quality improvements in hotels. *Journal of Quality Assurance in Hospitality & Tourism*, 3(3-4), 25-59.
- [17] Rao, Y., Yang M., & Yang, Y. (2018). Knowledge Sharing, Organizational Learning and Service Innovation in Tourism. *Journal of Service Science and Management*, 11(5), 510-526.
- [18] Úbeda-García, M., Claver-Cortés, E., Marco-Lajara, B., García-Lillo, F., & Zaragoza-Sáez, P. C. (2018). Continuous innovation in the hotel industry. *International Journal of Contemporary Hospitality Management*, 30(12), 3609-3631.
- [19] Wilkea, E. P., Costa, B. K., Freire, O. B. D. L., & Ferreira, M. P. (2019). Interorganizational cooperation in tourist destination: Building performance in the hotel industry. *Tourism Management*, 72, 340-351.
- [20] Nieves, J., & Diaz-Meneses, G. (2018). Knowledge sources and innovation in the hotel industry: Empirical analysis on Gran Canaria Island, a mature mass-tourism destination. *International Journal of Contemporary Hospitality Management*, 30(6), 2537-2561.
- [21] Salem, I. E. B. (2014). Toward better understanding of knowledge management: Correlation to hotel performance and innovation in five-star chain hotels in Egypt. *Tourism and Hospitality Research*, 14(4), 176-196.
- [22] Shaw, G., & Williams, A. (2009). Knowledge transfer and management in tourism organisations: Anemerging research agenda. *Tourism Management*, 30(3), 325-335.
- [23] Hallin, C. A., & Marnburg, E. (2008). Knowledge management in the hospitality industry: A review of empirical research. *Tourism Management*, 29(2), 366-381.
- [24] Gamble, P. R., & Blackwell, J. (2001). *Knowledge Management: A State of the Art Guide*. Kogan Page Publishers.
- [25] Chiu, H., & Fogel, J. (2014). The impact of manager influence tactics on innovation implementation of a knowledge management system. *International Journal of Innovation Science*, 6(4), 185-204.
- [26] Atapattu, A. W. M. M., & Jayakody, J. A. S. K. (2014). The interaction effect of organizational practices and employee values on knowledge management (KM) success. *Journal of Knowledge Management*, 18(2).
- [27] Castro, G. M. D., Delgado-Verde, M., Amores-Salvado, J., & Navas-López, J. E. (2013). Linking human, technological, and relational assets to technological innovation: exploring a new approach. *Knowledge Management Research & Practice*, 11(2), 123-132.
- [28] Ciabuschi, F., & Martin Martin, O. (2012). Knowledge ambiguity, innovation and subsidiary performance. *Baltic Journal of Management*, 7(2), 143-166.
- [29] Shamim, S., Cang, S., & Yu, H. (2017). Supervisory orientation, employee goal orientation, and knowledge management among front line hotel employees. *International Journal of Hospitality Management*, 62, 21-32.
- [30] Fiorini, V. (2022). *Why Knowledge Management Matters in the Hospitality Industry*. Available at: <https://bloomfire.com/blog/knowledge-management-in-hospitality-industry>.

- [31] Agyeiwaah, E., McKercher, B., & Suntikul, W. (2017). Identifying core indicators of sustainable tourism: a path forward? *Tourism Management Perspectives*, 24, 26-33.
- [32] Hjalager, A. M. (2010). A review of innovation research in tourism. *Tourism Management*, 31(1), 1-12.
- [33] Yiu, M., & Law, R. (2014). Review and application of knowledge management and knowledge sharing in tourism. *Asia Pacific Journal of Tourism Research*, 19(7),737-759.



# Legal Issues in Managing and Sharing Research Data

Jelena Banović<sup>1</sup>, Aleksandra Bradić-Martinović<sup>2</sup>

<sup>1,2</sup>Institute of Economic Sciences-Data Centre Serbia for Social Sciences, Belgrade, Serbia

<sup>1</sup>jelena.banovic@ien.bg.ac.rs, <sup>2</sup>abmartinovic@ien.bg.ac.rs

**Abstract**—Scientific research is directly related to the collected and processed data. Data manipulated within the natural and technical sciences are not subject to the same restrictions as data in the social sciences. Domestic researchers who collect data from individuals must be aware of the limits imposed by the Law on Personal Data Protection of the Republic of Serbia. This topic is particularly relevant to the Open Science and Open Access principle movement, for which the Ministry of Education, Science and Technological Development of the Republic of Serbia has dedicated itself through the adoption of the Open Science Platform in 2018. The paper aims to analyse and brings closer to researchers the restrictions within the two most important laws that are directly or indirectly implemented in our country - the Law on Personal Data Protection of the RS and GDPR, which is applied in the EU. Domestic researchers also must respect them in projects funded by EC or other EU financiers. The topic is covered through the presentation of the Data Center of Serbia for Social Sciences case study, a national infrastructure that deals with collecting, archiving, and sharing research data in the social sciences.

**Keywords** - data, open science, open access, legal framework, data centre serbia for social sciences

## I. INTRODUCTION

Data has always been a valuable resource, and efforts have been made to systematise and preserve it appropriately. With the development of digitalisation, they have become an integral part of all areas of human existence. Data sources can be different, and they also include personal data about one's identity, property, social and health status, but also data on business subjects, their balance sheets, clients, data on national and

supranational levels, open or protected, as well as data on our environment and much more.

However, a particular dimension is research data in science. As part of scientific exploration, researchers collect various scales and types of data. Some sciences, especially those which use measuring instruments, generate a massive amount of data, classified as Big Data. Based on the various data, science draws significant conclusions and achieves excellent discoveries, and very often, cooperation is the key to progress. A movement that advocated open communication among scientists appeared to open the possibility of the broadest scientific cooperation. OECD observes Open Science as a process that “encompasses unhindered access to scientific articles, access to data from public research, and collaborative research enabled by ICT tools and incentives” [1]. Despite the benefits that this movement has already brought to science and scientists, many issues still exist that prevent its spread and strengthening. Bearing in mind that this paper focuses on open research data, our goal is to point out a significant dimension of this problem - legal issues and considerations in the process of data management and sharing, with a focus on social science. Many researchers, especially in Serbia, are unaware of data's determinants - they are not informed about rights or obligations toward data, legally and ethically. A unique dimension of the problem can be seen in the social sciences that collect, process, deposit and share data on individuals. This field is subject to additional laws that do not affect data management and sharing within the natural and technical sciences.

Serbian researchers should realize that the future situation can only be more complicated. The Ministry of Education, Science and

Technological Development of the Republic of Serbia is increasingly putting pressure on implementing Open Science following the Open Science Platform adopted in 2018. In the first phase, it is insisted on implementing digital repositories in which all scientific publications will be stored and publicly available. In the next step, the same treatment is expected for research data.

With an aim to bring researchers as close as possible to the limitations in data management and sharing, together with their rights and possibilities, we will present elements upon the main document of Serbian national research infrastructure Data Center Serbia for Social Sciences - Policy and Procedures document is based.

## II. DATA CENTRE SERBIA FOR SOCIAL SCIENCES

Data Center Serbia for Social Sciences (DCS) [2] is the national data centre of the Republic of Serbia established in 2014 as an organisational unit of the Institute of Economic Sciences in Belgrade to identify significant data sources within a wide range of disciplines of social sciences, collect and prepare data for the long-term preservation and enable dissemination for scientific research and academic education [3]. The Center has been developed since 2012 with the support of the European Research Community and international projects funded by the European Commission [4] and the HORIZON2020 project - CESSDA SaW (Strengthening and Widening) [5], as well as by the Swiss National Science Foundation, SCOPES project - SEEDS (South-Eastern European Data Services) [6] DCS became a national research infrastructure in 2019 when the Ministry joined the Consortium of European Social Science Digital Archives – CESSDA ERIC [7] and assigned the service provider's role to the Institute of Economic Sciences. CESSDA is a leader in data curation and sharing with great expertise. CESSDA ERIC supported DCS from the first day until the present time.

Today, DCS is available to all Serbian researchers in the field of social sciences and fulfils its mission through activities of collecting, depositing, and sharing research data, representing Serbia in the European Research Area (ERA), training researchers in this field, and participating in the Open Science Team of the Republic of Serbia.

## III. LEGAL ISSUES IN DEALING WITH RESEARCH DATA IN SOCIAL SCIENCES

### A. Data Protection Laws

Legal restrictions are, in essence, highly formal and include penalties in case of non-compliance. Therefore, researchers must have clear guidelines regarding the data generated during the research process, sharing them among themselves or in Open Access data repositories such as Harvard Dataverse, Figshare, Zenodo, etc. However, the situation is very complex due to several problems. The first one is the lack of a unique definition of the term - "research data". According to the website Law insider [8], there are over 50 different definitions, and the three central covers research data as "information or data which is not Personal Data that is collected or generated in the performance of the Research and includes (but is not limited to) information that is collated or stored in the searchable form". Other consider it as "the result of observations or experimentation that validate research findings and that are published separately to the Article, which can include but are not limited to raw data, processed data, software, algorithms, protocols, and methods." and the third explains it as "documents in a digital form, other than scientific publications, which are collected or produced in the course of scientific research activities and are used as evidence in the research process, or are commonly accepted in the research community as necessary to validate research findings and results". Based on only three definitions, it is clear to what extent the approach and the way of observing this vital research category differ. The ignorance and imprecise determinants of the basic concept are confusing and put researchers at risk.

*Case study example. DCS collects, without a precise definition, quantitative and qualitative data in a wide range of social sciences and humanities (economics, education, employment and labour, ecology, conservation and land use, health, history, industry and management, law, criminology and legal systems, media, communication and languages, political science, psychology, sociology, society and culture, social welfare policy and systems). The data should be harmonised with one of the listed formats: spreadsheet and similar formats as the quantitative data and text and audio images/ photos and videos as the qualitative data.*

Many projects implemented in Serbia are funded by the European Commission or other

European Union funds. Within these projects, personal data protection is predominantly based on the principles of the General Data Protection Regulation – GDPR, introduced in May 2018. It was not the first law on personal data in the EU, and the GDPR replaced the previous one – the Directive on the use of personal data in the EU, which was in charge for almost 20 years. The main reason for changes was technological development and adjusting regulations to a contemporary, digitised economy and society. Reference [9] offered the systematisation of the main GDPR principles regarding scientific research data:

- the processing of personal data must follow the law and be entirely transparent for the person(s) who made the data available to researchers. All respondents involved in scientific research have the right to know exactly how their data will be handled during and after the study. In cases where the survey is not anonymous (e.g. focus group or interview), researchers are obliged to obtain Consent from respondents. Respondents have the right to withdraw their Consent at any time without explanation.
- if there is the respondents' Consent, the researchers must not go beyond the respondents' agreement. Without Consent, researchers are obliged to use them only for scientific analysis. There are exceptions when data are taken over by the state archives, national statistics, etc.).
- to reduce the probability of misuse of the amount of data collected from the respondents, it should be minimal and fully harmonised with the goals of scientific research.

Special attention to the place and time of data storage is also necessary. Data must be stored safely (protected from malicious attacks or negligence) and must not be kept longer than the period required for research. However, archiving or long-term data storage is also desirable under the GDPR, and it requires protected infrastructures, such as trustworthy digital repositories.

Following the example of the European Union, Serbia has also improved its legislation and, in November 2018, adopted the Law on

Personal Data Protection of the Republic of Serbia [10]. The law is basically in line with the GDPR and has been in force since August 2019. Unlike the legal delimitation of the broad term “research data”, the domestic Law on Personal Data Protection very unambiguously defines the term “personal data” as “any data relating to a natural person whose identity is determined or identifiable, directly or indirectly, mainly based on an identity mark, such as name and identification number, location data, identifiers in electronic communications networks or one or more features of his physical, physiological, genetic, mental, economic, cultural and social identity” [10]. In addition to being aware of the definition, researchers also must be informed of the differences between direct and indirect identifiers. In case they overlook the indirect identifiers, revealing a private person's identity is possible, which carries additional risks (more on this topic [11]). Personal data protection is critical when sensitive data is involved. According to the law, this category includes racial or ethnic origin, religious affiliation, political and philosophical beliefs, health status, trade union membership and sexual orientation and sexual life. Researchers who manage and share data on their respondents must be familiar with these elements of the Law, as well as with the numerous restrictions it imposes. Article 92 of the Law stipulates that restrictive measures regarding the collection of personal data shall not be applied if data processing is performed for scientific or historical research or statistical purposes. In addition, related to the deposit and storage of data from scientific research in the social sciences, it envisages deviation from the set guidelines for archiving in the public interest.

Anonymisation is the primary technique available to researchers that allow data to be securely manipulated in an international environment. Anonymised data are not subject to legal restrictions, but only if the process is performed professionally and reliably. Anonymisation is the process of wholly and permanently removing identification from data by converting personal information into aggregate data. Anonymised data can no longer be linked to individual data [11].

Case study example. *DCS operates under the following laws:*

- *Law on Personal Data Protection of the Republic of Serbia (“Official Gazette of the RS”, No. 87 of November 13, 2018);*

- *General Data Protection Regulation Directive - GDPR, 95/46/EC;*
- *Law on Copyright and Related Rights (Official Gazette of RS No. 104/2009);*
- *EU Copyright Directive in the Digital Single Market, EU, 2016/0280(COD);*
- *Law on Science and Research (“Official Gazette of RS”, No. 49 of July 8, 2019) and*
- *Law on the Science Fund of the Republic of Serbia (“Official Gazette of the RS”, No. 95/2018).*

In many cases, research funders understand the position of individual researchers and seek a professional assessment of the vulnerability of respondents within the research. To ensure compliance with laws and regulations, they require the decision of the Ethics Commission or at least a person qualified to assess the risk of manipulating specific data (Data Protection Officer – DPO). Decisions are mainly based on a clearly defined procedure - Data Protection Impact Assessment (DPIA), covered by Serbian Law in Article 54).

Case study example. *DCS decide on data compliance based on a Questionnaire for assessing the impact on the protection of personal data, which covers several topics:*

- *Basic information about the project or study within which the personal data will be processed (name, client, duration) and describe the life cycle of the data to be processed;*
- *Data anonymisation level (original form, partially or entirely anonymised);*
- *Data collection method (survey, interview, focus group);*
- *The level of compliance of the data management process with certain principles set out in the Law;*
- *Is the data in the sensitive data category;*
- *Will the data leave (physically or virtually) the borders of our country and*
- *Whether the data will be archived following Article 6 of the Law.*

Bearing in mind that institutions (universities and scientific institutes) in the social sciences do

not formally appoint Ethics Commissions, such as in medical research institutions, domestic researchers can address DCS for assessment. These assessments are internationally accepted.

Consent is one essential element that enables researchers in the social sciences to share their data as Open Access. It is required throughout the entire data lifecycle (collecting, analysing, archiving, sharing, re-using). “Informed Consent” for personal data is a voluntary, determined, informed and unambiguous expression by which that person, by a statement or explicit affirmative action, gives consent to the processing of personal data relating to him. Consent needs to fulfil several requests. It needs to be:

- **Voluntary:** the person giving it must not be influenced, have the right to refuse or revoke the decision without any consequences and must not be in a dependent relationship;
- **Certain:** it must have clear information about the scope and consequences;
- **Informed:** the content and requirements of consent should be easy to understand, easily accessible, transparent and written in simple language, especially when information is given to children;
- **Active:** “silence as a sign of approval” is not taken into account, and
- **Revoking consent** must be as simple as providing it.

Adding a clause on data sharing and archiving allows the respondent to decide on a specific notice of purpose. This empowers them and allows them to choose whether or not to contribute to a research project and make their data available for future research projects. The best way to obtain the informed person’s consent to data sharing is to identify and explain all possible future manipulation of their data and offer the participant the opportunity to consent or refuse.

Formally speaking, Consent can be oral and written, but also one-time and permanent. Written Consent is in accordance with the law and is usually a request of the Ethics Committee or similar body and provides better protection to the researcher. However, in some cases, it is impossible to obtain it when the respondents are, for example, helpless people or felons. Also,

seeking this type of written consent may frighten the respondent. Verbal Consent is only valid if recorded on audio or video recording. Its disadvantage is that it is often difficult to cover all activity elements in video/audio format, which causes distrust among respondents. One-time Consent is simple and non-threatening to respondents but restricts data usage to specific research and prevents archiving and sharing. Permanent Consent is most appropriate for covering the whole data life cycle. Researchers should keep in mind the advantages and limitations of each category to avoid turning to their respondents (again) if they have not received their permission to deposit and share data in Open Access.

Case study example. *DCS provides several levels of access to data in order to protect researchers and respondents (regardless of whether the data is anonymous or not):*

- *Public-Use-Files (PUF) are data and documents that can be accessed through the dissemination portal without any restrictions;*
- *Free-Use-Files (FUF) are data and documents that can be used exclusively for the purposes of scientific analysis in academic research and teaching and which can be accessed without the permission of the depositor. Through the ordering system, either by e-mail or online form, the user can gain access and free download files from this category. Prior user registration is required, and*
- *Scientific-Use-Files (SUFs) are data and documents that can only be accessed with the written approval of the depositor. The user must familiarise DCS with the details and specify their research objectives. DCS sends a request for approval to the depositor and allows the user access only if the depositor submits written approval. In order to access these files, the user must sign an agreement on the terms of use.*

Depending on the specific research, the data collected, and the accompanying documentation, researchers in the social sciences in Serbia, when depositing data sets, can choose one of the offered levels of protection. However, it should be noted that the goal of DCS is to make the data

“Open as Possible and Protected as Necessary” to get as close as possible to full Open Access.

### *B. Data as Intellectual Property*

Technological progress has enabled the opening of scientific papers and data collected within research. Retaining copyright in researchers’ work in the new environment has become challenging. There are many examples of abuse and appropriation. The situation is further complicated when it comes to published data sets. Researchers should be familiar with licensing, ownership, copyright, and intellectual property to protect their work and avoid threatening other people’s rights. Many academic institutions offer their researcher advice to protect intellectual property and copyright, but data on this topic are still insufficiently clear. However [12] drew attention to this very complex issue, noting that copyright protection regarding data (regardless of form - quantitative or qualitative) depends on the local regulations of each country.

One of the most common ways to protect intellectual property concerning data is licensing. A license is a legal instrument for a copyright holder or content producer to enable a second party to use their content and apply certain conditions and restrictions to those uses. When it comes to the UK, researchers can use one of three groups of licenses. In the case of public-funded research, researchers have a formal obligation to make their data open after a period of the embargo (if needed). OGL (Open Government License for Public Sector Information) [12] is typically used in this case. If the research project is funded by a third party, e.g. business sector, usually a full license applies, at least for a while. Finally, researchers mainly use Creative Commons licenses in the case of other funders.

Creative Commons is an international organisation [12] that provides free licensing through public copyright licenses. Trademark is CC completed with main additional terms: BY for attribution - implies the recognition of intellectual property rights of data creators in the process of copying, distribution, presentation, performing, doing derivative work, or remixing; SA for share alike derivative work - those who use data and publish the results of research obtained based on other people’s data must ensure that their research results have the same or higher level of restriction as to the original, not less; NC – non-commercial is used to exclude the possibility of commercial use and ND – non-



derivative work, since 4.0 version that allows derivative work, but without the possibility of sharing it.

Case study example. *When it comes to intellectual properties, DCS advises its depositors to:*

- *Decide, at the beginning of the research project, the person who will own the copyright on data. It is not always straightforward, especially in large teams from different institutions or, even, countries. In most cases, Principal Investigator (PI) or the project leader is the copyright owner, but in multinational studies, local team leaders can obtain copyright on country-specific data. It is very important to make a clear decision about this subject to avoid possible conflict after the project.*
- *Suppose the data is at a higher level of protection than Open Access (restricted use or embargo). In that case, researchers can use depositing options listed in Illustration 4, and in other cases, use Creative Commons licenses unless the contract with funders provides otherwise. DCS uses CC 4.0 version for publically available data.*
- *DCS provides guidelines and examples for data citation. Citation ideally needs to contain author(s) of the data set (in accordance with the agreement with the funder or within the research team, as explained), publication date, title, edition, version, feature name, resource type (for example database or data set), Unique numeric fingerprint (UNF), identifier (in most cases DOI or Handle) and location. An example of data set citation in APA style is:*

Smith, T.W., Marsden, P.V., & Hout, M. (2011). General social survey, 1972-2010 cumulative file (ICPSR31521-v1) [data file and codebook]. Chicago, IL: National Opinion Research Center [producer]. Ann Arbor, MI: Inter-university Consortium for Political and Social Research [distributor]. doi: 10.3886/ICPSR31521.v1.

CESSDA ERIC put an additional effort to provide learning materials for researcher in social sciences – Data Management Expert Guide – DMEG [13]. The main purpose of DMEG is to support researchers with knowledge of how to make their data FAIR which basically mean to be findable, understandable, sustainably accessible and reusable. Experts from all over Europe join the effort to provide easy-to-use guide with numerous examples and country specific approaches.

#### IV. CONCLUSION

Researchers in science must have a clear vision of their rights and obligations. The introduction of the concept of Open Science and Open Access to scientific publications and data collected within the research further complicates the situation. In some research areas, reliance on codes of ethics is sufficient. However, when it concerns data in the social sciences, which are collected from private individuals, researchers must be familiar with the laws related to this area. Endangering privacy can have catastrophic consequences for an individual, especially if a person belongs to a vulnerable group.

#### ACKNOWLEDGEMENT

The authors acknowledge support from the Ministry of Education, Science and Technological Development of the Republic of Serbia and CESSDA ERIC.

#### REFERENCES

- [1] *Organisation for Economic Co-operation and Development (OECD)*. (January 2022). Accessed: 15.February 2022 <https://www.oecd.org/sti/inno/open-science.htm#:~:text=Open%20science%20encompasses%20unhindered%20access,by%20ICT%20tools%20and%20incentives>
- [2] *Data Centre Serbia for Social Sciences (DCS)* (2022). Accessed: 2.3.2022 <https://datacenterserbia.com/sr/>
- [3] *Data Centre Serbia for Social Sciences (DCS)*. (2022). Accessed: 1.3.2022. <https://datacenterserbia.com/en/basic-information>
- [4] *FP7 SERSIDA project - Support for the Establishment of National/Regional Social Science Data Archives*. Accessed: 1.3.2022. <http://www.serscida.eu/en/>.
- [5] *HORIZON2020 project CESSDA SaW (Strengthening and Widening)*. Accessed: 1.3.2022. <https://cessdasaw.eu/>
- [6] *SCOPES project - SEEDS (South-Eastern European Data Services)*. Accessed: 1.3.2022. <https://seedspjproject.ch/>
- [7] *CESSDA ERIC*. Accessed: 1.3.2022. <https://www.cessda.eu/>

- [8] *Law Insider*. (2022). Accessed: 16.2.2022. <https://www.lawinsider.com/dictionary/research-data>
- [9] Greene, T., Shmueli, G., Ray, S., & Fell, J. (2019). Adjusting to the GDPR: The Impact on Data Scientists and Behavioral Researchers. *Big Data*, 7(3), 140-162.
- [10] Zakon o zaštiti podataka o ličnosti Republike Srbije, "Službeni glasnik RS", 87/13/2018.
- [11] Bradić-Martinović, A., & Zdravković, A. (2013). Zaštita privatnosti – anonimizacija podataka. In: *V naučni skup USPON – Preduzetništvo kao šansa: zbornik radova*. Valjevo: Univerzitet Singidunum (pp. 206-213).
- [12] Hrynaszkiewicz, I., Cockerill, M.J. (2012). Open by default: a proposed copyright license and waiver agreement for open access research and data in peer-reviewed journals. *BMC Research Note*, 5(494), 1-12.
- [13] CESSDA ERIC. *Data Management Expert Guide – DMEG*, Accessed: 20. February 2022. <https://www.cessda.eu/Training/DMEG>



# Simulation of Evacuation of Immobile Persons as a Modern Evacuation Problem

Radoje B. Jevtić<sup>1</sup>, Ivana D. Janković<sup>2</sup>, Momčilo B. Randjelović<sup>3</sup>

<sup>1,2</sup>School for Electrical Engineering “Nikola Tesla”, Niš, Serbia

<sup>3</sup>University Business Academy in Novi Sad, Faculty of Social Sciences Belgrade, Serbia

<sup>1</sup>milan.jvyc@gmail.com, <sup>2</sup>ivana.etstesla@gmail.com, <sup>3</sup>mocaprof@gmail.com

**Abstract**—Evacuation of people, animals and material properties from an endangered object or from endangered location presents always actual, complex and open problem. Even with careful preparation, unexpected events can occur and endanger the safety and lives of people. The risks and possibilities of such events are significantly increased and complicated if immobile persons participate in the evacuation. The prediction of evacuation in these cases can be very complex and difficult because of many different factors important for evacuation. One of potentially good, safe and economically proofed way for this problem is the usage of simulation software. This paper was written to present the use of Pathfinder simulation software in simulation of evacuation objects with presence of immobile persons and advantages of this approach in solving of this complex and very often present problem.

**Keywords** - evacuation, immobile, simulation, Pathfinder

## I. INTRODUCTION

One of the most important tasks related to human, animal and material properties safety is an evacuation. Evacuation generally presents the safest, the shortest and the fastest form of relocation and sheltering of people, animals and material properties from endanger object or location to the secure place or location. Evacuation must be well organised, planed, conceived and realised. The causes that lead to an evacuation could be different: fire, natural disasters (earthquake, flood, powerful winds, thunder strike or else), terrorism etc. Many different events in past showed that evacuation

can always go wrong and that consequences could be catastrophic. The main reasons for this are the presence of fear and panic, enough level of proper education and presence of injured, hard mobile or immobile persons.

In the dependence where the critical event has happened, evacuation can be realised from the height, from the surface and from the depth. Radiological, chemical and biological contamination depend special evacuation regimes. Every evacuation, no matter how good and precise was planed can be endangered by several factors, such as: direct fire spreading, explosion occurrence, object's construction elements destruction, fear, panic, the occurrence of unconscious and injured persons etc. These factors were impossible to be predicted completely, so it is from crucial importance to as much as possible analyse and predict these factors and potential situations.

Injured, hard mobile or immobile persons may already be present in object or at the location, or they can be the consequence of the evacuation reason. These persons mostly demand help of other people for their movement and move significantly slower than other persons. In the case that these persons are located in high objects with stairs or elevators, the time needed for complete evacuation can be much longer and evacuation by itself can be much more complex.

Designing of evacuation times and scenarios with presence of immobile or hard mobile persons presents very complex and demanding task. This task purports prediction of all

potential situations and scenarios with presence and influence of several very hard predictable factors and their consequences. One of very good way for evacuation prediction and calculation of evacuation times, routes and other important factors for evacuation is the usage of simulation software.

So, the main reason for writing of this paper is the use of simulation software on analyse and presumption of potential scenarios of immobile or hard mobile persons evacuation as very precise, sure, safe and economic way for evacuation prediction [1-4].

## II. PATHFINDER SIMULATION SOFTWARE

Pathfinder presents an agent-based egress and human movement simulator, designed by Thunderhead engineering company and it is intended to provide a graphical user interface for simulation design and execution with possibilities of 2D and 3D visualization of results. The simulation object can be drawn directly in Pathfinder, or it can be imported from another software (such as Auto Cad, for example). It is possible to draw walls, doors, elevators, stairs and include them into calculation. Pathfinder software is able to support two different simulation modes: steering mode and SFPE mode. The first mode purports that occupants use so called steering way for moving and interacting. The main characteristic for this mode is to present human movement and behavior as much as possible. The second mode purports that occupants are able to penetrate each other without avoiding, but there are limitations in the presentations of doors, flow limit and density. Pathfinder, such as similar software demands very strong hardware configuration for comfortable work, what purports 64-bit Windows 8 Pro with an Intel Core i7 2.60 GHz processor or stronger, 8 GB of RAM or more, NVIDIA NVS 5200M graphics card or similar etc.

There are many versions of Pathfinder software on the market. The current version of this software is Pathfinder 2022.02.0383, while Pathfinder versions used for purposes of this paper were 2019 and 2020 [5].

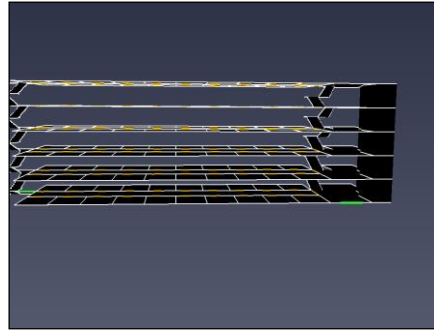

Fig. 1. Pathfinder simulation model presentation [6].



Fig. 2. Evacuation moment for the first scenario [6].

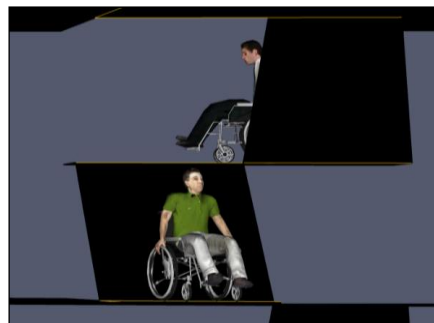

Fig. 3. Evacuation moment for the third scenario [6].

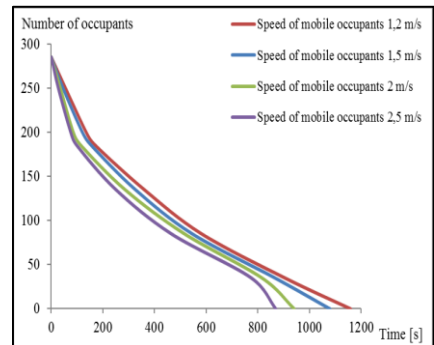

Fig. 4. An example of simulation results for the fourth scenario [6].

### III. EXAMPLE OF SIMULATION OF EVACUATION OF IMMOBILE PERSONS FROM SANITARY OBJECT-HOSPITAL

Hospitals present very important objects for every society. These objects often purport several floor objects with presence of lot of humans-doctors, medical staff, patients, ordinary people etc. The evacuation of these objects presents very hard and complex task, no matter what was the evacuation reason. Patients can be mobile, hard mobile or immobile and they are usually located in patient rooms. Immobile patients are usually sited in medical beds or wheelchairs. Patients in wheelchairs mostly can push their wheelchairs without assistance of other people although there are cases that they demand assistance of other people. On the other hand, patients in medical beds always need assistance of other people. Their movement is hard and slow in ordinary conditions, while under evacuation it can be serious problem in the view of crowds and jams.

Simulation object for this example presents hospital with patients. The hospital object had dimensions 47 m x 11 m in base, while the height of every floor was 3 m. Hospital had five floors, so the complete height of hospital was 16 m. Every floor was connected to other with ordinary stairs, elevators and emergency stairs. The width dimension of ordinary stairs was 120 cm and these stairs were realized as double stairs. There were 100 rooms at each floor, 20 per floor for patients. The rest of rooms located at the first floor were for medical personal. The dimensions of every room were 4 m x 4 m x 3 m. The connections between floors also were five elevators. Two elevators were with dimensions 2,5 m x 1,8 m, while the rest three were with dimensions 1,5 m x 1 m. The maximal speed for bigger elevators was 0.7 m/s while the maximal speed for smaller elevators was 1,1 m/s.

The complete number of humans in hospital was 285. From that number, 125 were doctors, medical staff and patients with ability to move, while 160 were immobile patients. Immobile patients were in wheelchairs, and they were located on every floor, 32 per floor. Also, at every floor were located 35 doctors, medical staff and non-medical personnel. All of the occupants were uniformly arranged around hospital. These occupants had two possibilities to leave the object. One possibility was the main

exit, while the second possibility was emergency exit. The width of both exit's doors was 2 m.

There were four different simulation scenarios analyzed. The first scenario was the evacuation of the object but only with ordinary stairs usage. This scenario purported that all of occupants had to use the same evacuation route, with big possibilities for jams. The second scenario was the evacuation of the object but only with emergency stairs usage. This scenario also purported that all of occupants had to use the same evacuation route, with big possibilities for jams. The third scenario was the evacuation of the object but only with elevators and ordinary stairs usage. This scenario purported that all of occupants could use different evacuation routes. The fourth scenario was the evacuation of the object but only with ordinary and emergency stairs usage. This scenario also purported that all of occupants could use different evacuation routes. Occupants speeds (doctor, medical staff, mobile patients) for every of four scenarios were 1,2 m/s, 1,5 m/s, 2 m/s and 2,5 m/s. Wheelchair speed (immobile patients) was 0,69 m/s.

Simulation analyze showed that the fastest evacuation times were for the third scenario, while the slowest evacuation times were for the second scenario.

Simulation object of the hospital in Pathfinder software, some simulation moments from the first and from the third scenario and simulation results for the fourth scenario as an example are presented on Figs.1-4 [6].

### IV. EXAMPLE OF SIMULATION OF EVACUATION OF IMMOBILE PERSONS FROM RESIDENTIAL OBJECT-HIGH BUILDING

High residential buildings today present very often locations for life and work. Technology and construction advancement resulted that modern residential buildings have several hundred meters height with lot of humans inside. These buildings possess modern construction solutions with fast elevators, ordinary stairs, emergency stair etc. Evacuation of these objects presents very demand and complex task.

Simulation model of residential building present object with base of 17m x 17m and twelve floors. The height of every floor was 2.54 m.

TABLE I. SIMULATED SCENARIOS FOR RESIDENTIAL BUILDING WITH OR WITHOUT ELEVATORS, ORDINARY STAIRS AND EMERGENCY STAIRS.

Scenario	Elevators usage	Ordinary stairs usage	Emergency stairs usage
I	yes	yes	yes
II	yes	yes	no
III	yes	no	yes
IV	no	yes	yes
V	yes	no	no
VI	no	yes	no
VII	no	no	yes

There were four flats at every floor. The connections between floors were two elevators, ordinary stairs and emergency stairs. There were seven different scenarios. Simulated scenarios are presented in Table I.

Simulation speeds of occupants for every of seven scenarios were 1.2 m/s, 1.5 m/s, 1.8 m/s, 2.1 m/s and 2.5 m/s. Immobile occupants were in medical beds and wheelchairs. Their speeds were limited, from 0.4 m/s to 1.3 m/s for wheelchairs and from 0.2 m/s to 1.2 m/s for medical beds. For wheelchairs, there were one or two persons for assistance, while for medical beds there were four persons for assistance. There were three different cases for every scenario: the case without immobile occupants, the case with 5 % of immobile occupants randomly arranged (10 immobile occupants, 5 with wheelchairs and 5 with medical beds) and the case with 10 % of immobile occupants randomly arranged (20 immobile occupants, 10 with wheelchairs and 10 with medical beds).

Simulation model of residential buildings, some simulation moments and example of simulation results for the first scenario as scenario with the fastest times for evacuation, as an example, are presented on Figs.5-8 [7].

Wheelchair`s dimensions were 0.78 m x 0.5 m x 0.5 m, while the medical bed`s dimensions were 2 m x 0.9 m x 0.75 m. It was very important because the width of ordinary stairs was 1.25 m while the width of emergency stairs was 0.9 m.

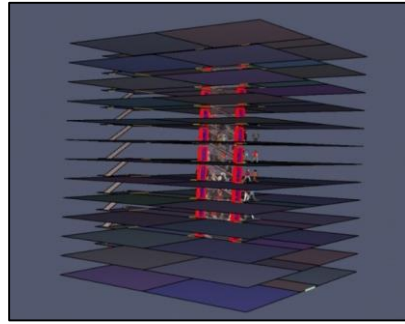

Figure 5. Simulation model of residential building in Pathfinder [7].

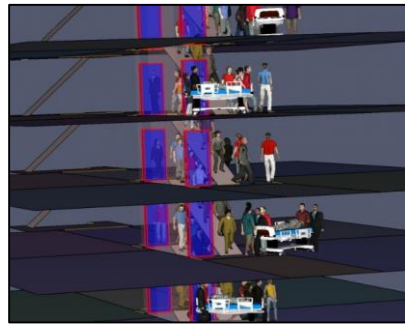

Figure 6. Simulation moment for the first scenario [7].

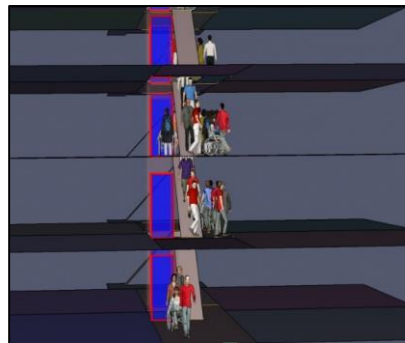

Figure 7. Simulation moment for the second scenario [7].



Figure 8. Simulation moment of the evacuation of immobile person in medical bed [7].

The limitation of this paper doesn't allow to show the simulation results for all of seven scenarios. Because of that, only the first scenario where elevators, ordinary stairs and emergency stairs were enabled is presented on Fig.9 where marks: “-■-” present the first case, “- - -” present the second case and “...●...” present the third case.

#### V. EXAMPLE OF SIMULATION OF EVACUATION OF IMMOBILE PERSONS FROM SANITARY OBJECT-GERONTOLOGY INSTITUTIONS

One of the special sanitary objects present sanitary institutions. These objects are intended for life and accommodation old persons. In the most of cases, these persons are immobile or hard mobile and they often demand permanent medical treatment and monitoring of their condition. In sanitary objects, patients can be stationed in ordinary beds and medical mobile beds. For their movement, they can use also wheelchairs, they can walk with different types of apparatus, they can walk with assistance of other people or they can walk alone (statistically the rarest case). Generally, evacuation of every sanitary object presents complex and demanded task, but in this case, it is particularly complex and particularly demanded.

Simulation object for this example was the gerontology institutions with ground floor and four additional floors. The object's base dimensions were 80 m x 20 m, while the height of every floor was 3.15 m. The whole object was divided related to different purposes. Ground floor was the floor for personal only, with several rooms. The first floor was the floor for patients in medical beds. They were located in 16 rooms, two patients in every room. The second floor was the floor for patients that needed wheelchairs. They were also located in 16 rooms, two patients in every room. The third and the fourth floor were the floors where mobile patients were located. They were also located in 16 rooms per floor, two patients in every room. Every room at the first, the second, the third and the fourth floor had approximately area of 16 m<sup>2</sup>. Medical beds and wheelchairs had standard dimensions, 200 cm x 90 cm x 75 cm for medical beds and 110 cm x 65 cm x 92 cm for wheelchairs. The complete number of patients was 144, 32 per every of four floors. Medical personal was located uniformly at every floor, including ground floor. The complete number of medical and administrative personal

was 44, so the complete number of all occupants in object was 172.

The connection between floors were ordinary stairs, emergency stairs and four elevators (two cargo elevators and two passenger elevators). The width of ordinary stairs was 1.5 m while the width of emergency stairs was 1.2 m. The width of the main doors of the object was 2 m while the width of the door for emergency stairs was 1.3m. Simulation model of gerontology institution in Pathfinder is presented on Fig.10.

There were four different simulation scenarios for this object. The first scenario purported that all elevators were enabled and all available stairs (ordinary and emergency) were enabled. The second scenario purported that all elevators were disabled but all available stairs were enabled. The third scenario purported that all elevators were disabled and ordinary stairs were disabled, but emergency stairs were

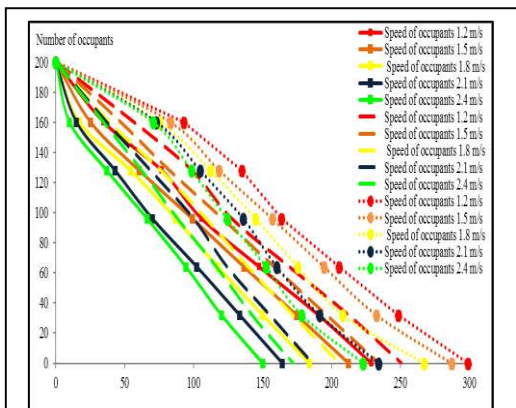

Figure 9. An example of simulation results for the first scenario [7].

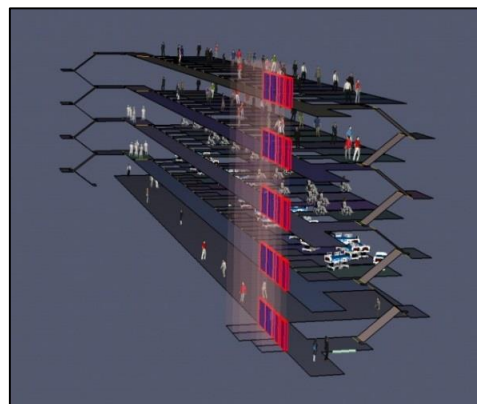

Figure 10. Simulation model of gerontology institution in Pathfinder [8].



enabled. The fourth scenario purported that all elevators were disabled and emergency stairs were disabled, but ordinary stairs were enabled. Every of four scenarios were simulated for four different cases. Patients in wheelchairs demanded assistance of one person, while the patients in medical beds demanded assistance of two persons. The characteristics for every of four cases are presented in Table II.

TABLE II. SIMULATION CHARACTERISTICS FOR EVERY OF FOUR CASES.

Case	Speed of mobile patients [m/s]	Speed of patients in wheelchair [m/s]	Speed of patients in medical beds [m/s]	Speed of medical and administrative personal [m/s]
I	0.5	0.5-1.3	0.2-0.9	1
II	0.6	0.5-1.3	0.2-0.9	1
III	0.7	0.5-1.3	0.2-0.9	1
IV	0.8	0.5-1.3	0.2-0.9	1

Because of limitation of this paper, only the simulation moments for the first, the second and the third scenarios are presented on Figs.11-13 while an example for simulation results for the first scenario is presented on Fig.14 [8].

## VI. CONCLUSION

Evacuation of people, animals and material properties generally can be very difficult, complex and demanding task. Although many objects have clear and signalized evacuation plan with precise determined evacuation routes and evacuation directions, many different factors can cause that in the moment things and occurrences proceed at the wrong way. Some of these factors are panic and fear. Evacuation becomes significantly more complex and demanding in the presence of hard mobile or immobile persons.

The usage of simulation software has great value in the evacuation prediction-it is possible without human victims, material damage or spending lot of time to simulate different scenarios with different conditions and predict the optimal option-the most secure evacuation

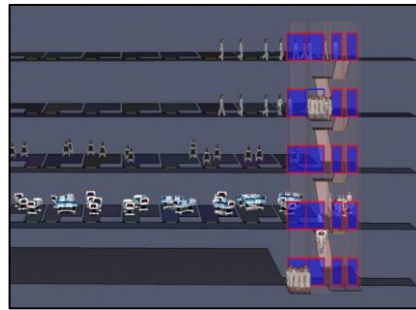

Figure 11. Simulation moment for the first scenario [8].

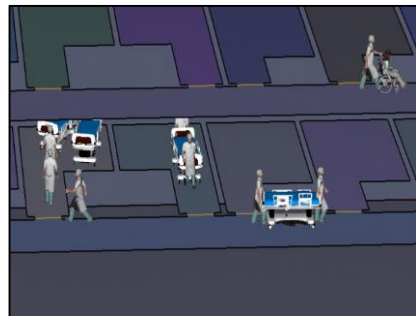

Figure 12. Simulation moment for the second scenario [8].

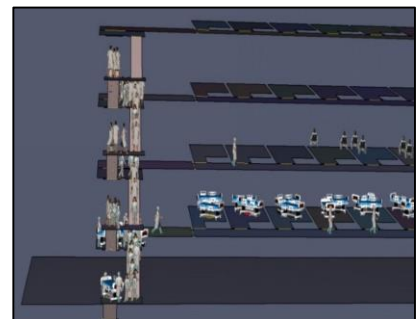

Figure 13. Simulation moment for the third scenario [8].

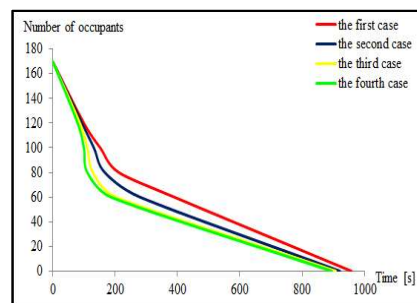

Figure 14. An example of simulation results for the first scenario [8].

route and the shortest and the safest evacuation time. Noted examples in simulation software Pathfinder directly prove that simulation software must be obligation tool for engineers in their work and design.

#### REFERENCES

- [1] Jevtić, B. R., & Ničković, T. J. (2013). Simulation of residential object evacuation. In *57th ETRAN CONFERENCE, Zlatibor, ISNB* (pp. 978-86).
- [2] Jevtić, R. (2016). Simulation of evacuation situations in order to protect human lives and material property. *NBP. Nauka, bezbednost, policija, 21*(2), 35-48.
- [3] Jevtić, R. B. (2019). Material for the preparation of the professional exam in the field of fire protection. *Gradski Vatrogasni Savez Niš*, 502-507.
- [4] Jevtic, R. (2020). Simulation of fire as a form of safety and protection of human lives and material assets. *Facta Universitatis, Series: Working and living environmental protection*, 171-184.
- [5] *Thunderengineering* (2020). *Pathfinder user manual*, (pp. 6-12, 84, 92).
- [6] Jevtić, R. (2019). Sanitary objects evacuation with presence of immobile occupants. *Zdravstvena zaštita, 48*(1), 61-68.
- [7] Jevtić, R. B. (2020). Residential building evacuation: Simulation of potential evacuation scenarios with presence of immobile persons. *Tehnika, 75*(6), 814-822.
- [8] Jevtić, R. (2021). Safety in health-the evacuation of immobile persons from gerontology institution. *Zdravstvena zaštita, 50*(1).



# A Multiple-Criteria Approach to RFID Solution Provider Selection

Gabrijela Popović<sup>1</sup>, Goran Milovanović<sup>2</sup>, Đorđe Pucar<sup>3</sup>

<sup>1,3</sup>Faculty of Applied Management, Economics and Finance, Belgrade, University Business Academy in Novi Sad, Belgrade, Serbia

<sup>2</sup>Faculty of Economics, University of Niš, Niš, Serbia

<sup>1</sup>gabrijela.popovic@mef.edu.rs, <sup>2</sup>goran.milovanovic@eknfak.ni.ac.rs, <sup>3</sup>djordje@mef.edu.rs

**Abstract**—Nowadays, many organizations use the RFID technology for tracking and tracing the flows of materials, goods and other contents. It is very important to select adequate provider of the RFID technology that offers solutions aligned with the needs of the particular business. This paper proposes subjective-objective approach based on the Multiple-Criteria Decision-Making (MCDM) methods that could contribute to the facilitation of decision process and selection of the adequate solution provider. The weights of the criteria are defined by using the subjective Simplified Pivot Pairwise Relative Criteria Importance Assessment (PIPRECIA-S) and the objective Preference Selection Index (PSI) methods, while the final ranking of the alternatives is performed with the help of the COmprehensive Distance Based RAnking (COBRA) method. Four alternative RFID solution providers are assessed against ten evaluation criteria. The obtained results proved the applicability and reliability of the proposed approach.

**Keywords** – COBRA, PIPRECIA-S, PSI, RFID solution provider

## I. INTRODUCTION

The optimization of operating in the logistics field requires monitoring of all flows of goods and other resources to detect possible bottlenecks or issues [1]. Today is impossible to secure the flawless realization of activities in logistics without timely information about mentioned flows [2]. The efficiency of the organization increases through the employment of so-called *Smart Logistics* [3]. Smart Logistics is characterized by the intention to enable the implementation of intelligent and lean supply chains where the exchange of information is

based on the application of new information and communication technologies (ICT), automatic identification technologies, and sensors [4]. According to Uckelmann [5], leading technologies of that kind include:

- Identification – Radio Frequency Identification Technology (RFID),
- Locating – Real Time Location System (RTLS) like GPS and others,
- Sensing – like temperature and humidity sensors.

RFID technology is often used in logistics for the automatic identification of goods and other resources' movement over radio waves [6]. These small electronic devices called RFID tags have a chip and antenna, and they are used similarly as a product barcode, for example. This is a wireless technology that allows identification and automated tracking of a tag placed on a particular item [7]. Until now, RFID technology is used in various business fields which proves the following research studies [8-15].

Adoption of RFID technology in an organization is a very complex task that requires qualified professional assistance. RFID solution providers help in conducting and realizing the projects regarding the introduction of the appropriate RFID technology. Besides, the providers, also, care about maintaining and upgrading the installed systems [16]. It is necessary to select and engage an adequate RFID solution provider, which is not an easy assignment for the management of the organization. The selection process should include various types of evaluation criteria which

ensure finding the optimal alternative. All mentioned indicate the Multiple-Criteria Decision-Making (MCDM) methods as a helpful tool that simplified and accelerates decision process.

The main direction of the MCDM methods and models is supporting decision-making processes in various business fields. So far, many different MCDM methods have been proposed [17-21]. The selection of an MCDM method for application does not depend only on the problem type; it depends on the opinion and judgment of the decision-maker as well. Each of these methods has a goal to give an optimal solution regarding the present conditions, and every one of them is suitable for application for resolving different types of problems [22-28].

The MCDM methods have been used in finding the optimal solutions in the logistic field, as well. The authors have proposed the application of the MCDM methods and models for the selection of a logistic center location [29], in reverse logistics [30], for estimation of the logistics' performance [31], in the case of the third-party logistics provider selection [32], in the area of RFID technologies [33-34], etc.

This article is directed to a proposal of an MCDM-based model that will help in the assessment and selection of the optimal RFID solution provider. To achieve the set goal, the subjective-objective approach is introduced. Namely, for defining the criteria weights the combination of the subjective Simplified Pivot Pairwise Relative Criteria Importance Assessment (PIPRECIA-S) [35] and the objective Preference Selection Index (PSI) [36] methods are used. It is expected that, in this way, the gained results would be more reliable and representative. For the assessment and ranking of the considered alternative RFID solution providers, the COMprehensive Distance Based Ranking (COBRA) method [37] is applied. The COBRA method has recently been introduced and its capacity is not fully observed. The four RFID solution providers from Serbia are submitted under estimation against ten evaluation criteria. The conducted research and gained results are presented through the following sections: Section II contains a proposed model; in Section III the numerical example is demonstrated; and finally, the conclusion is given.

## II. A PROPOSED MODEL

### A. The PIPRECIA-S Method

The PIPRECIA-S method represents the improved version of the earlier introduced PIPRECIA method [38]. Difference between them is illustrated by the fact that computation procedure of the PIPRECIA-S method requires the comparison of all criteria only with the first criterion. This a lot facilitates the application and decision process. The potential of this method is not examined much giving the fact that it has been relatively recently proposed [39]. The computation procedure presented here relies on that one shown in the paper by Stanujkic et al. [35].

Step 1. Forming a set of evaluation criteria.

Step 2. Determining the relative significance  $s_j$  of each criterion, apart from the first, in the following way:

$$s_j = \begin{cases} 1 & \text{if } c_j > c_1 \\ 1 & \text{if } c_j = 1 \\ 1 & \text{if } c_j < 1 \end{cases}, \quad (1)$$

where  $j \neq 1$ . As in the PIPRECIA method, the value of  $s_1$  is set to 1. Values of  $s_j$  belong to the interval (1, 1.9] when  $c_1 > c_j$  that is to the interval [0.1, 1) when  $c_1 < c_j$ .

Step 3. Computing the value of coefficient  $k_j$  in the following manner:

$$k_j = \begin{cases} 1 & \text{if } j = 1 \\ 1 - s_j & \text{if } j > 1 \end{cases}. \quad (2)$$

Step 4. Computing the recalculated weight  $q_j$  as it is shown:

$$q_j = \begin{cases} 1 & \text{if } j = 1 \\ \frac{1}{k_j} & \text{if } j > 1 \end{cases}. \quad (3)$$

Step 5. Defining the relative weights of the criteria in the following way:

$$q_j = \frac{q_j}{\sum_{k=1}^n q_k}. \quad (4)$$

*B. The PSI Method*

Maniya and Bhatt [36] introduced the PCI method which belongs to the group of objective MCDM methods. Besides it enables defining the criteria weights on the base of the input data, it allows assessing the involved alternative solutions and their final ranking. Until now, the PSI method has been used for the solution of various kinds of problems which proves the following research studies [40-42]. The computing procedure could be precisely illustrated by following a series of steps [36].

Step 1. As with PIPRECIA-S, here is also necessary to define the evaluation criteria.

Step 2. Creating the initial decision matrix  $D$  as follows:

$$D = [x_{ij}]_{m \times n}, \tag{5}$$

where  $x_{ij}$  is the ratings of the alternative  $i$  regarding the criterion  $j$ ,  $m$  represents the number of alternatives, and  $n$  is the number of criteria.

Step 3. Forming the normalized decision matrix in the following manner:

$$r_{ij} = \frac{x_{ij}}{\max_i x_{ij}} \text{ if } j \in B, \tag{6}$$

$$r_{ij} = \frac{\min_i x_{ij}}{x_{ij}} \text{ if } j \in C, \tag{7}$$

where  $B$  designates the benefit criteria, and  $C$  indicates the cost criteria.

Step 4. Computing the preference variation value related to each criterion as follows:

$$\chi_j = \sum_{i=1}^m (r_{ij} - \bar{r}_j)^2, \tag{8}$$

where  $\bar{r}_j$  designates the mean value of normalized ratings of criterion  $j$  computed in the following way:

$$\bar{r}_j = \frac{1}{m} \sum_{i=1}^m r_{ij}. \tag{9}$$

Step 5. Computing deviation in the preference variation value in the following manner:

$$\Omega_j = 1 - \chi_j. \tag{10}$$

Step 6. Determining the criteria weights as follows:

$$w_j = \frac{\Omega_j}{\sum_{j=1}^n \Omega_j}. \tag{11}$$

Step 7. Computing the preference selection index of alternatives by using Equation (12):

$$S_i = \sum_{j=1}^n r_{ij} w_j. \tag{12}$$

Step 8. Ranking the alternatives in decreasing order. The alternative with the highest  $S_i$  is the best option.

*C. The COBRA Method*

The COBRA method is introduced by Krstić et al. [37]. This method represents a distance-based MCDM method. Given the fact that it has been relatively recently proposed, its possibilities have not been fully examined yet. The application of the COBRA method contains the following steps.

Step 1. Defining a decision matrix that involves the alternatives and evaluation criteria.

Step 2. Forming the normalized decision matrix as it is presented:

$$\Delta = [r_{ij}]_{m \times n}, \tag{13}$$

where:

$$r_{ij} = \frac{a_{ij}}{\max_i a_{ij}}. \tag{14}$$

Step 3. Generating the weighted normalized decision matrix  $\Delta_w$  as follows:

$$\Delta_w = [w_j \times r_{ij}]_{m \times n}, \tag{15}$$

where  $w_j$  designates the relative weight of criterion  $j$ .

Step 4. Determining the positive ideal ( $PIS_j$ ), negative ideal ( $NIS_j$ ), and average solution ( $AS_j$ )

regarding each criterion function in the following way:

$$PIS_j = \max_i (w_j \times r_{ij}), \quad (16)$$

$$\forall_j = 1, \dots, n \text{ for } j \in B,$$

$$PIS_j = \min_i (w_j \times r_{ij}), \quad (17)$$

$$\forall_j = 1, \dots, n \text{ for } j \in C,$$

$$NIS_j = \min_i (w_j \times r_{ij}), \quad (18)$$

$$\forall_j = 1, \dots, n \text{ for } j \in B,$$

$$NIS_j = \max_i (w_j \times r_{ij}), \quad (19)$$

$$\forall_j = 1, \dots, n \text{ for } j \in C,$$

$$AS_j = \frac{\sum_{i=1}^m (w_j \times r_{ij})}{n}, \quad (20)$$

$$\forall_j = 1, \dots, n \text{ for } j \in B, C,$$

where  $B$  represents the set of benefit, and  $C$  is the set of cost criteria.

Step 5. Now, the distance from the positive ideal ( $d(PIS_j)$ ), the negative ideal ( $d(NIS_j)$ ), the positive ( $d(AS_j^+)$ ) distance from the average solution, and the negative distances ( $d(AS_j^-)$ ) from the average solutions should be determined. This procedure is performed as follows:

$$d(S_i) = dE(S_j) + \sigma \times dE(S_j) \times dT(S_j), \quad (21)$$

$$\forall_j = 1, \dots, n,$$

where  $S_j$  denotes any solution ( $PIS_j$ ,  $NIS_j$  or  $AS_j$ ),  $\sigma$  is the correction coefficient defined in the following way:

$$\sigma = \max_i dE(S_j)_i - \min_i dE(S_j)_i, \quad (22)$$

where  $dE(S_j)_i$  and  $dT(S_j)_i$  are the Euclidian and Taxicab distances, respectively, which are computed for the positive ideal solution in the following way:

$$dE(PIS_j)_i = \sqrt{\sum_{j=1}^n (PIS_j - w_j \times r_{ij})^2}, \quad (23)$$

$$\forall_i = 1, \dots, m, \forall_j = 1, \dots, n,$$

$$dT(PIS_j)_i = \sum_{j=1}^n |PIS_j - w_j \times r_{ij}|, \quad (24)$$

$$\forall_i = 1, \dots, m, \forall_j = 1, \dots, n.$$

The Euclidian and Taxicab distances are calculated in the following way for the negative ideal solution:

$$dE(NIS_j)_i = \sqrt{\sum_{j=1}^n (NIS_j - w_j \times r_{ij})^2}, \quad (25)$$

$$\forall_i = 1, \dots, m, \forall_j = 1, \dots, n,$$

$$dT(NIS_j)_i = \sum_{j=1}^n |NIS_j - w_j \times r_{ij}|, \quad (26)$$

$$\forall_i = 1, \dots, m, \forall_j = 1, \dots, n.$$

The Euclidian and Taxicab distances are calculated for the positive distance from the average solution as follows:

$$dE(AS_j)_i^+ = \sqrt{\sum_{j=1}^n \tau^+ (AS_j - w_j \times r_{ij})^2}, \quad (27)$$

$$\forall_i = 1, \dots, m, \forall_j = 1, \dots, n,$$

$$dT(AS_j)_i^+ = \sum_{j=1}^n \tau^+ |AS_j - w_j \times r_{ij}|, \quad (28)$$

$$\forall_i = 1, \dots, m, \forall_j = 1, \dots, n,$$

$$\tau^+ = \begin{cases} 1 & \text{if } AS_j < w_j \times r_{ij} \\ 0 & \text{if } AS_j > w_j \times r_{ij} \end{cases}. \quad (29)$$

Finally, mentioned distances for the negative distance from the average solution is computed as follows:

$$dE(AS_j)_i^- = \sqrt{\sum_{j=1}^n \tau^- (AS_j - w_j \times r_{ij})^2}, \quad (30)$$

$$\forall_i = 1, \dots, m, \forall_j = 1, \dots, n,$$

$$dT(AS_j)_i^- = \sum_{j=1}^n \tau^- |AS_j - w_j \times r_{ij}|, \quad (31)$$

$$\forall_i = 1, \dots, m, \forall_j = 1, \dots, n,$$

$$\tau^- = \begin{cases} 1 & \text{if } AS_j > w_j \times r_{ij} \\ 0 & \text{if } AS_j < w_j \times r_{ij} \end{cases}. \quad (32)$$

Step 6. The alternatives involved in the procedure are ranked in ascending order. The ranking order is determined by using the following Equation (33):

$$dC_i = \frac{d(PIS_j)_i - d(NIS_j)_i - d(AS_j)_i^+ + d(AS_j)_i^-}{4}, \quad (33)$$

$$\forall_i = 1, \dots, m.$$

where  $d(C_i)$  represents comprehensive distances.

### III. THE NUMERICAL EXAMPLE

This section presents the numerical example to illustrate the possibilities of the proposed model in evaluating and selecting an adequate RFID solution provider. Four providers from Serbia are submitted under evaluation, but the names of the organizations are not revealed to avoid their advertising.

These providers are evaluated according to the criteria proposed in the paper of Sari [16]. The evaluation criteria and their explanations are as follows:

- C<sub>1</sub>** – RFID implementation proficiency. Experience in managing RFID projects.
- C<sub>2</sub>** – Specialization in the application. Level of experience in the particular industry.
- C<sub>3</sub>** – Customer references. The names of organizations that used services of the considered RFID provider and their number.
- C<sub>4</sub>** – Technical capacity. Satisfactory level of technical and engineering ability for system creation and utilization.
- C<sub>5</sub>** – Capacity for innovation. The ability for developing and implementing new ideas and technology solutions.
- C<sub>6</sub>** – Capacity for service and support. Obtaining the customer with all needed assistance and support.

**C<sub>7</sub>** – Financial security. Possessing enough financial strength to support the customers when it is necessary.

**C<sub>8</sub>** – Total cost of ownership. These costs involve the costs of acquisition and operating, as well as the costs of upgrade and replacement.

**C<sub>9</sub>** – Flexibility of a platform. An RFID system should not require switching operating systems, platforms, and application software.

**C<sub>10</sub>** – Scalability. The RFID system should be flexible. Also, it should acknowledge the appropriate set of standards which ensures that it will not require additional costs for replacement or upgrades in the future.

On the base of the presented criteria the initial decision matrix is formed. An expert from the considered field estimated the alternative RFID providers regarding the given criteria. It should be mentioned that all criteria are treated as benefit. The alternatives are assessed by using the grades 1 to 5 (1 – the worst grade, 5 – the best grade). The initial decision matrix is presented in Table I.

Any multiple-criteria assessment requires the determination of the criteria weights. The appropriate specification of the criteria weights leads to a more adequate and reliable ranking of the alternatives. In the present case, the criteria weights are defined by applying a subjective-objective approach.

The subjective approach relies on the PIPRECIA-S method. For the need of using the mentioned method, three decision-makers were involved in the decision procedure. The main reason for that is to minimize the subjectivity of decision-makers and gain reliable results.

TABLE I. INITIAL DECISION MATRIX.

Alternatives	Criteria									
	C <sub>1</sub>	C <sub>2</sub>	C <sub>3</sub>	C <sub>4</sub>	C <sub>5</sub>	C <sub>6</sub>	C <sub>7</sub>	C <sub>8</sub>	C <sub>9</sub>	C <sub>10</sub>
A <sub>1</sub>	4	5	5	4	5	5	4	5	4	4
A <sub>2</sub>	4	4	4	4	5	3	4	3	3	4
A <sub>3</sub>	3	4	5	3	3	4	3	5	3	4
A <sub>4</sub>	3	3	5	4	4	3	4	3	4	3



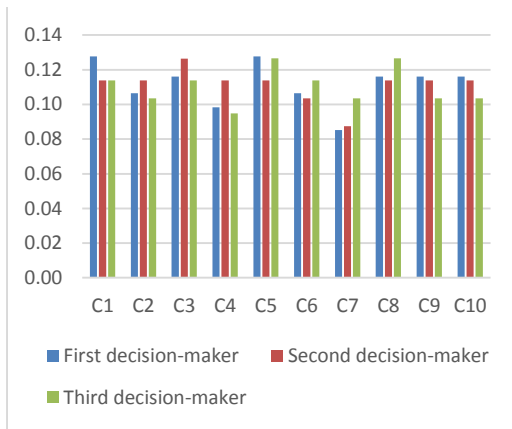

Figure 1. Criteria weights obtained by using the PIPRECIA-S method.

The weights are obtained for each decision-maker separately by using Equations (1)-(4), and they are presented in Fig.1.

Fig.1 clearly shows that decision-makers had different perspective about the significance of considered criteria.

The objective approach in defining the criteria weights implies the application of the PSI method. Based on the input data and Equations (5)-(12) the objective criteria significance is determined. Fig. 2 illustrates the criteria weights determined by using the PSI method.

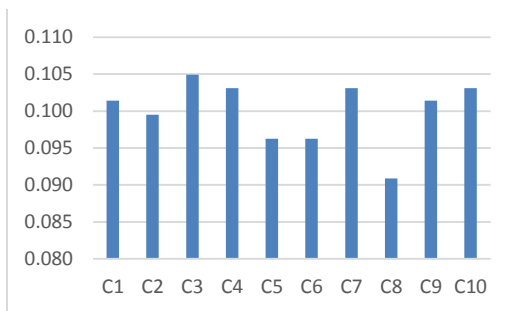

Figure 2. Criteria weights obtained by using the PSI method.

The significance obtained by using the PSI method varies between 0.091 and 0.105. This leads to the conclusion that the PSI method resulted in much more uniform criteria weights than the PIPRECIA-S method.

The geometric mean of the obtained criteria significances is calculated to gain a final weight of the considered criteria. The results are presented in Table II.

The final results show that the criteria weights, mainly, have nearly equal importance. For example, criteria  $C_1$  – *RFID implementation proficiency*,  $C_3$  – *Customer references*, and  $C_5$  – *Capacity for innovation* share the first position. Additionally, the rest of the criteria are second or third-ranked although there are seven more. This leads to the conclusion that all the considered criteria should be carefully observed during the selection of an adequate RFID solution provider.

Finally, for obtaining the results regarding the optimal selection of RFID solution provider, the COBRA method is applied. By using Equations (13)-(33) the ranking order of alternatives is defined and presented in Table III.

TABLE II. THE FINAL CRITERIA WEIGHTS.

Criteria		Weight
$C_1$	RFID implementation proficiency	0.11
$C_2$	Specialization in the application	0.10
$C_3$	Customer references	0.11
$C_4$	Technical capacity	0.09
$C_5$	Capacity for innovation	0.11
$C_6$	Capacity for service and support	0.10
$C_7$	Financial security	0.09
$C_8$	Total cost of ownership	0.10
$C_9$	Flexibility of a platform	0.10
$C_{10}$	Scalability	0.10

TABLE III. THE RANK OF THE ALTERNATIVE RFID SOLUTION PROVIDERS.

Alternatives	$d(PIS)$	$d(NIS)$	$d(AS^+)$	$d(AS^-)$	$dC$	Rank
$A_1$	0.0000	0.1016	0.0462	0.0000	-0.0369	1
$A_2$	0.0691	0.0682	0.0232	0.0325	0.0026	2
$A_3$	0.0714	0.0599	0.0227	0.0405	0.0073	3
$A_4$	0.0820	0.0511	0.0159	0.0399	0.0137	4

According to the obtained results, the best-positioned RFID solution provider is  $A_1$ . This signifies that this provider best meets the given set of criteria. The worst choice, in this case, is the provider marked as  $A_4$ . The initial decision-matrix shows that the estimations of the characteristics of this provider were not very good.

#### IV. CONCLUSION

The performing of the activities in the logistics implies the application of the appropriate technologies. In recent years, RFID technologies have become very popular and used for the automatic identification of goods and articles. Depending on the business type it is important to select and implement appropriate RFID technology. The main objective of this paper was to introduce the applicable MCDM-based approach intended for the facilitation of the decision-making process in the case of the selection of the appropriate RFID solution provider. The introduced approach is based on the PIPRECIA-S, PSI, and COBRA methods. The first two methods were used for defining the criteria' importance, while the third one was applied for the final assessment and ranking of the considered providers regarding the involved criteria. The final results marked RFID solution provider  $A_1$  as the most acceptable. Considering the input data, the obtained results are fully justified and relevant.

Although the approach proved its applicability, it has limitations, too. First, the COBRA method is relatively complex and involves an extensive computation procedure, so it could be difficult for the application to persons unfamiliar with the MCDM field. Besides, the estimation of the involved alternatives presented in Table I is performed by one expert from the field. The input data would be more realistic if more experts from the field were engaged in obtaining estimations needed for further procedure. All computations were performed by using crisp numbers, although it is obvious that many estimations could not be precisely expressed by a single value. So, it is highly recommended to introduce and use appropriate extensions of the applied methods here proposed. These limitations together represent the propositions for future research studies. Nevertheless, the proposed approach enabled obtaining relevant scientific results. These candidates it as a convenient tool for resolving the various problems in the logistics field.

Additionally, its potential should be verified by observing, analyzing, and solving the issues in other business fields.

#### REFERENCES

- [1] Casella, G., Bigliardi, B., & Bottani, E. (2022). The evolution of RFID technology in the logistics field: a review. *Procedia Computer Science*, 200, 1582-1592.
- [2] Popova, I., et al. (2021). Application of the RFID technology in logistics. *Transportation Research Procedia*, 57, 452-462.
- [3] Kirch, M., Poenicke, O., & Richter, K. (2017). RFID in logistics and production—Applications, research and visions for smart logistics zones. *Procedia Engineering*, 178, 526-533.
- [4] Woschank, M., Rauch, E., & Zsifkovits, H. (2020). A review of further directions for artificial intelligence, machine learning, and deep learning in smart logistics. *Sustainability*, 12(9), 3760.
- [5] Uckelmann, D. (2008, September). A definition approach to smart logistics. In *International Conference on Next Generation Wired/Wireless Networking* (pp. 273-284).
- [6] Hu, L., Xiang, C., & Qi, C. (2020). Research on traceability of cold chain logistics based on RFID and EPC. In *IOP Conference Series: Materials Science and Engineering* 790(1), 012167.
- [7] Kis, P., & Alexandru, M. (2015). Real time monitoring and tracking system for an item using the RFID technology. *Review of The Air Force Academy*, (3), 71.
- [8] Zhu, X., Mukhopadhyay, S. K., & Kurata, H. (2012). A review of RFID technology and its managerial applications in different industries. *Journal of Engineering and Technology Management*, 29(1), 152-167.
- [9] Ajami, S., & Rajabzadeh, A. (2013). Radio Frequency Identification (RFID) technology and patient safety. *Journal of research in medical sciences*, 18(9), 809.
- [10] Singh, N. K., & Mahajan, P. (2014). Application of RFID technology in libraries. *International Journal of Library and Information Studies*, 4(2), 1-9.
- [11] Bibi, F., Guillaume, C., Gontard, N., & Sorli, B. (2017). A review: RFID technology having sensing aptitudes for food industry and their contribution to tracking and monitoring of food products. *Trends in Food Science & Technology*, 62, 91-103.
- [12] Azevedo, S. G., & Carvalho, H. (2012). Contribution of RFID technology to better management of fashion supply chains. *International Journal of Retail & Distribution Management*, 40(2), 128-156.
- [13] Duan, K. K., & Cao, S. Y. (2020). Emerging RFID technology in structural engineering – A review. *Structures*, 28, 2404-2414.
- [14] Fahmy, A., Altaf, H., Al Nabulsi, A., Al-Ali, A., & Aburukba, R. (2019). Role of RFID technology in smart city applications. In *2019 international conference on communications, signal processing, and their applications (ICCSPA)* (pp. 1-6). IEEE.
- [15] Motroni, A., Buffi, A., & Nepa, P. (2021). A survey on indoor vehicle localization through RFID technology. *IEEE Access*, 9, 17921-17942.

- [16] Sari, K. (2013). Selection of RFID solution provider: A fuzzy multi- criteria decision model with Monte Carlo simulation. *Kybernetes*, 42(3), 448-465.
- [17] Stanujkic, D., Popovic, G., Karabasevic, D., Meidute-Kavaliauskiene, I., & Ulutaş, A. (2021). An integrated simple weighted sum product method—WISP. *IEEE Transactions on Engineering Management*.
- [18] Puška, A., Stević, Ž., & Pamučar, D. (2022). Evaluation and selection of healthcare waste incinerators using extended sustainability criteria and multi-criteria analysis methods. *Environment, Development and Sustainability*, 24(9), 11195-11225.
- [19] Stević, Ž., Pamučar, D., Puška, A., & Chatterjee, P. (2020). Sustainable supplier selection in healthcare industries using a new MCDM method: Measurement of alternatives and ranking according to COmpromise solution (MARCOS). *Computers & Industrial Engineering*, 140, 106231.
- [20] Khan, N. Z., Ansari, T. S. A., Siddiquee, A. N., & Khan, Z. A. (2019). Selection of E-learning websites using a novel Proximity Indexed Value (PIV) MCDM method. *Journal of Computers in Education*, 6(2), 241-256.
- [21] Keshavarz-Ghorabae, M., Amiri, M., Zavadskas, E. K., Turskis, Z., & Antucheviciene, J. (2021). Determination of objective weights using a new method based on the removal effects of criteria (MERECE). *Symmetry*, 13(4), 525.
- [22] Stojčić, M., Zavadskas, E. K., Pamučar, D., Stević, Ž., & Mardani, A. (2019). Application of MCDM methods in sustainability engineering: A literature review 2008–2018. *Symmetry*, 11(3), 350.
- [23] Emovon, I., & Oghenyerovwho, O. S. (2020). Application of MCDM method in material selection for optimal design: A review. *Results in Materials*, 7, 100115.
- [24] Kumar, A., et al. (2017). A review of multi criteria decision making (MCDM) towards sustainable renewable energy development. *Renewable and Sustainable Energy Reviews*, 69, 596-609.
- [25] Chowdhury, P., & Paul, S. K. (2020). Applications of MCDM methods in research on corporate sustainability: A systematic literature review. *Management of Environmental Quality: An International Journal*, 31(2), 385-405.
- [26] Tan, T., Mills, G., Papadonikolaki, E., & Liu, Z. (2021). Combining multi-criteria decision making (MCDM) methods with building information modelling (BIM): A review. *Automation in Construction*, 121, 103451.
- [27] Sotoudeh-Anvari, A. (2022). The applications of MCDM methods in COVID-19 pandemic: A state of the art review. *Applied Soft Computing*, 109238.
- [28] Kaya, I., Çolak, M., & Terzi, F. (2018). Use of MCDM techniques for energy policy and decision- making problems: A review. *International Journal of Energy Research*, 42(7), 2344-2372.
- [29] Žak, J., & Węgliński, S. (2014). The selection of the logistics center location based on MCDM/A methodology. *Transportation Research Procedia*, 3, 555-564.
- [30] Wang, H., et al. (2019). An integrated MCDM approach considering demands-matching for reverse logistics. *Journal of cleaner production*, 208, 199-210.
- [31] Chejarla, K. C., Vaidya, O. S., & Kumar, S. (2022). MCDM applications in logistics performance evaluation: A literature review. *Journal of Multi-Criteria Decision Analysis*, 29(3-4), 274-297.
- [32] Raut, R., Kharat, M., Kamble, S., & Kumar, C. S. (2018). Sustainable evaluation and selection of potential third-party logistics (3PL) providers: An integrated MCDM approach. *Benchmarking: An International Journal*.
- [33] Büyüközkan, G., Karabulut, Y., & Arsenyan, J. (2017). RFID service provider selection: An integrated fuzzy MCDM approach. *Measurement*, 112, 88-98.
- [34] Lu, M. T., Lin, S. W., & Tzeng, G. H. (2013). Improving RFID adoption in Taiwan's healthcare industry based on a DEMATEL technique with a hybrid MCDM model. *Decision Support Systems*, 56, 259-269.
- [35] Stanujkic, D., Karabasevic, D., Popovic, G., & Sava, C. (2021). Simplified pivot pairwise relative criteria importance assessment (PIPRECIA-S) method. *Romanian Journal of Economic Forecasting*, 24(4), 141.
- [36] Maniya, K., & Bhatt, M. G. (2010). A selection of material using a novel type decision-making method: Preference selection index method. *Materials & Design*, 31(4), 1785-1789.
- [37] Krstić, M., Agnusdei, G. P., Miglietta, P. P., Tadić, S., & Roso, V. (2022). Applicability of Industry 4.0 Technologies in the Reverse Logistics: A Circular Economy Approach Based on Comprehensive Distance Based RANking (COBRA) Method. *Sustainability*, 14(9), 5632.
- [38] Stanujkic, D., Zavadskas, E. K., Karabasevic, D., Smarandache, F., & Turskis, Z. (2017). *The use of the pivot pairwise relative criteria importance assessment method for determining the weights of criteria*. Infinite Study.
- [39] Aytekin, A. (2022). Determining criteria weights for vehicle tracking system selection using PIPRECIA-S. *Journal of process management and new technologies*, 10(1-2), 115-124.
- [40] Sahir, S. H., et al. (2018). The Preference Selection Index method in determining the location of used laptop marketing. *International Journal of Engineering & Technology*, 7(3.4), 260-263.
- [41] Attri, R., & Grover, S. (2015). Application of preference selection index method for decision making over the design stage of production system life cycle. *Journal of King Saud University-Engineering Sciences*, 27(2), 207-216.
- [42] Bharathi, A. P., Pallavi, D. R., Ramachandran, M., Ramu, K., & Prasanth, V. (2022). A Study on Preference Selection Index Multi-Criteria Decision Making Techniques. *Data Analytics and Artificial Intelligence*, 2(1), 20-25.

# The Moderating Role of Employee Commitment and its Impact on Employee Involvement and Organizational Productivity

Soumi Majumder<sup>1</sup>

<sup>1</sup>Business Administration Department, Future Institute of Engineering and Management, Kolkata, India

<sup>1</sup>soumi.majumder@teamfuture.in

**Abstract**—The concepts and approaches that managers use now a day have changed due to deregulation, changing values of workers, international competition, and the growth of advanced information technology. Organizational Development interventions make productivity improvement through training activities, compensation management, decision-making techniques, and participative activity in management. This helps to cultivate and sustain a culture in the organization that gives value addition to employee participation and involvement. Engaged employees are productive employees, they have emotions and obligations to their organization. They are true performers and contribute to accomplishing the goals of the business. Therefore, a moderating role of organizational commitment has an influence on employee involvement practices and the field productivity and this is the major concern of this study.

**Keywords** - organization, employee, performance, moderating, commitment, involvement

## I. INTRODUCTION

In the modern era of management in business, organizational development and change management are inevitable. Organizations must succeed and must remain competitive, advanced, and progress with time. The concepts and approaches that managers use now a day have changed due to deregulation, changing values of workers, international competition, and the growth of advanced information technology [1].

Organizational development is a set of interventions that improve the organizational effectiveness and the well-being of employees. These interventions are applied at the individual, technological and structural levels. This is basically planned change efforts. It is well established that organizational development and change are interrelated concepts that may include different components of the organizational systems. It has the potential to make positive outcomes for the organization. To enact new behaviors and encourage individuals' successful implementation of change in the workplace is very much required. In this way, desired changes are achieved. A positive change must occur while active participation, attitudes, behavior, and practices of individuals are involved.

Human resource management practices like selection, training and development programs, performance appraisal, compensation management, internalization commitment, compliance commitment, identification commitment, etc. help to bring changes.

The culture includes behaviors, practices, processes, and attitudes that the organization espouses. In these phenomena, culture plays a vital role when organizational change is a key concern. Over time, change is measured in terms of quality, productivity, profitability, effectiveness, efficiency, and many more [2,3].

## II. ORGANIZATIONAL COMMITMENT AND PRODUCTIVITY

According to Burke and Litwin in the year 1992, a working climate of participation and adequate pay for performance generate positive results of the outcome. Earlier Rosenberg and Rosenstein in 1980 had proposed the model where they said that increase in participative activity leads to an increase in productivity. OD interventions make productivity improvement through training activities, compensation management, decision-making techniques, and participative activity in management. This helps to cultivate and sustain a culture in the organization that gives value addition to employee participation and involvement. The major concern of every organization is organizational productivity; in general, productivity is a standard measure which assesses organizational performance and its effectiveness. Productivity has been expressed in many terms i.e. quality and quantity of output, sales and profitability, completion of scheduled processes, and many more way. Another major indicator of organizational productivity is absenteeism. The measurement technique of productivity varies on the organization's policy. Productivity may define as the enhancement of values over time. The success formula of an organization is based on productivity; thus, productivity becomes a crucial factor. Organizational development occurs through productivity and based on productivity, OD interventions are introduced and implemented gradually [4,5].

Another important factor named organizational commitment is associated with organizational productivity. It is an explosion of interest in the concept of high-performance-high commitment work culture. This includes advanced and superior technology, effective task design, adequate planning, congruent structure, and methodologies [6]. Many researchers asserted the framework where they defined individuals and teams should be highly committed to technology, structure, work design, and strategy. Several reviews had been revealed that employee participation in management has a positive influence on productivity that leads to high commitment levels in business. The summation of employee involvement and employee commitment is the result of organizational qualitative productivity. Employee engagement and organizational efficiency are interrelated. It is necessary for all

organizations; employee engagement practices must be attractive under human resource systems. If it is found that organizational commitment is the moderator, HR practices must encourage and motivate people to create a culture of employee involvement and commitment.

Under Section 2, the relationship between organizational commitment and productivity has been discussed, the Conceptual model of Employee involvement and organizational productivity is reported in Section 3, in Section 4 Discussion is reported and finally, the Conclusion is under Section 5.

The organizational commitment has been defined as it is an employee involvement process toward the organization; commitment is basically individual's emotional attachment for their workplace. Commitment has three components, such as i) it is a strong belief of individuals for organizational objectives, goals and values, ii) on behalf of the organization willful effort to work always and iii) a strong relationship and membership between employee and organization. Therefore, it is said that employee commitment to the organization is the bond and responsibility of workforce for accomplishment of organizational mission and vision. The three types of commitments exist named as affective commitment, continuance commitment and normative commitment. When employee has emotional attachment for his/ her organization, knows the goals and enjoys membership fully then it is termed as affective commitment [7]. There is a consideration where costs associated with discontinuing the relationship with employees and it reflects with a readiness on sustainability in the workplace, it is called continuance commitment. Normative commitment includes a sense of obligation where employee thinks his/her duty should remain loyal to the organization.

High production is possible when there is a high participation and involvement of the members exists. They should be highly committed to their organization for generating qualitative and quantitative output. Thus, organizational operational efficiencies will be automatically increased. It is stated that organizations that give encouragement to their workforce for making high commitment would get better profit from efficiency benefits [8,9]. Moreover, it is seen a positive climate of workplace affects productivity. Commitment has positive impact on output level. High

participation, engagement, collaboration are essential particulars to tackle human systems. HR practices can be enhanced by commitment of employees; it helps to achieve desired organizational outcomes. Sometimes the concept high performance- high commitment work system is also known as high involvement plants and productive workplaces. It is revealed by several researches' that there is a relationship among engagement, commitment and productivity. Employee participation could make a better-quality decision-making process [10]. Employee autonomy has a positive impact on attitudes and behaviour and it fulfils their psychological needs for competence. It makes proper understanding for the people about the desire of high production and leading to the outcomes. The organizations that believe in employee autonomy and authority, have promoted employee involvement. Employee participation in management creates an attractive decision making programme. As the employees have the authority to share their inputs, i.e. ideas, suggestions, thoughts, opinions, so that productivity level of the organizations are highly affected. This paradigm shifts are reflected to their behaviours as they are continuously motivated to high standard performance for accomplishment of goals [11].

There is a relation between power and commitment as it is well stated that success of human resource practices requires employee authority and autonomy that will lead to committed employees [12]. Research has shown that organizations should set up appropriate policies for high performance and productivity. One of the most striking factors of high -performance high -commitment system is empowerment that must provide opportunities to workforce and make value addition to their contribution. To get the job done in a proper managed way the organizational management is always expecting from employees a high level of performance. More the employees engage more the organization earns productivity, therefore there is no such limitation if commitment is high. The linking pin among power, organizational commitment and organizational productivity has given the birth of efficient and effective workplace.

### III. CONCEPTUAL MODEL OF EMPLOYEE INVOLVEMENT AND ORGANIZATIONAL PRODUCTIVITY

Fig.1. is the representation of the model, where organization commitment has played a moderating role between employee involvement and organization productivity. In this conceptual framework employee involvement has been explained by four major factors, such as: i) power, ii) reward, iii) knowledge/skills, and v) information. These factors have a positive impact on employee engagement levels or employee involvement levels. It means if the employees of the organization enjoy all of these four factors enthusiastically, their level of commitment automatically will enhance and it will show qualitative and quantitative impact on the level of productivity. A higher level of productivity is the significance of a high-performance organization. In this section, the four factors of employee involvement are very important as these influence EI much [13]. Power is the authority of employees. When employees have the right or permission to do something in their organization they feel autonomy. They have the right to decision-making regarding any issues in their work and workplace.

An employee who enjoys autonomy must be performed well. They are allowed to access various resources of the organization so that a feeling of authority makes them have higher involvement, when employees are highly engaged it leads to a high level of commitment. Employees' performance should be recognized by management, they need appreciation, recognition, and reputation for contributing their best [14]. They should be motivated in their job duties and workplace too. Therefore, it is seen that if employees are rewarded periodically for the outstanding performance, they have a high involvement level. Similarly, the skills and knowledge of employees are also playing a key role in this juncture. Employees should possess' appropriate skills and knowledge regarding their job. The job duties and responsibilities must be clear to them. They can utilize their expertise in such a way that should match their skills with their job description. Employees should know clearly what is expected from them, and on the basis of that, they can show their performance with ease. Their level of involvement will also get high.

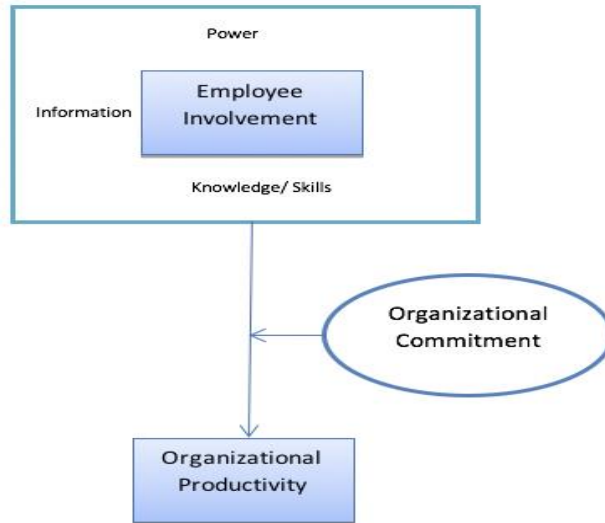

Figure 1. Conceptual Model of Employee Involvement and Organizational Productivity

Finally, the fourth-factor information is contributing to EI accordingly. The right kind of information makes the organization function efficiently [15,16]. Employee involvement must occur effectively toward the job and organization. It is based on proper and authentic data and information. When data availability and accessibility are high employees feel a high level of job satisfaction. They do not face any kind of obstacles while working. Effective communication and cooperation among employees also generate easy accessibility of information. The level of employee involvement gets high due to greater job satisfaction. Here it has been revealed that all four factors of EI have a positive impact on the productivity of the business. The moderator employee commitment is getting high significance due to the joint effect of four factors of EI. If the four factors work properly then the commitment level of employees will be enhanced. The positive feeling of job satisfaction generates a high level of organizational commitment. Moreover, it is very obvious of generating high productivity in order to establish the moderating effect of organizational commitment [17]. A committed employee produces huge in terms of quality and quantity. They might be loyal and have a positive obligation to their organization. In this way, an organization can earn reputation, recognition, and revenue in the market and able to create a striking image in front of the rest of the world.

#### IV. DISCUSSIONS

In this study, the moderating effect of organizational commitment has been discussed effectively. Productivity is the performance evaluation component of every organization. The organizational objective is based on its achievement of output. Business organizations have the intention to grow and develop their functions over time. If we consider individual-level performance and group-level performance and sum up both criteria, we will have the exact picture of organizational performance and its effectiveness. At this juncture, the key ingredient of organizational commitment has played an active role between employee involvement and productivity. Technological gradation, work design, the structure of the business, adequate planning, appropriate career development opportunities, training and development facilities, methods of doing work, etc. have made employee engagement high. The individual and group of employees should enjoy these mentioned particulars while they work [18,19]. Employers have the responsibility to provide all the necessary facilities and services to their workforce to make them happy at their job. Human capital is the most effective resource. The proper allocation and utilization of human capital will help to achieve the goal of the entire system [20]. With the help of productivity activity firms become competitive in the market and emerge of

sustainability becomes long-term. To manage human-oriented systems enlarged participation, collaboration, cooperation, etc. are fragmented ingredients. When employee commitment [21,22] is playing the moderating role, it gives a high influence on employee engagement [23,24] and an increased level of productivity [25,26]. Fig. 1. in this study has clearly depicted the relationship between employee involvement and organizational productivity.

## V. CONCLUSIONS

Engaged employees are productive employees, they have emotions and obligations to their organization. They are true performers and contribute to accomplishing the goals of the business. There are many factors that make employee engagement levels high, i.e. management support, effective recruitment and selection policy, opportunities for training and development, attractive succession planning, appropriate performance appraisal system, interpersonal relationship with colleagues, acceptable policy making for all levels of management, and so on [27,28]. Research has revealed that employees' job satisfaction creates a higher level of employee commitment. The parameter of job satisfaction is measured by the applicability of different factors of employee involvement. Therefore, satisfied employees are committed employees. Organizational commitment is the sequel of organizational productivity.

## REFERENCES

- [1] Igella, R. (2014). Factors influencing employee commitment: A case of Kenya civil aviation authority (Doctoral dissertation, United States International University-Africa).
- [2] Markos, S., & Sridevi, M. S. (2010). Employee engagement: The key to improving performance. *International journal of business and management*, 5(12), 89.
- [3] Collier, J., & Esteban, R. (2007). Corporate social responsibility and employee commitment. *Business ethics: A European review*, 16(1), 19-33.
- [4] AbuKhalifeh, A. N., & Som, A. P. M. (2013). The antecedents affecting employee engagement and organizational performance. *Asian Social Science*, 9(7), 41-46.
- [5] Vandenberghe, C., Bentein, K., Michon, R., Chebat, J. C., Tremblay, M., & Fils, J. F. (2007). An examination of the role of perceived support and employee commitment in employee-customer encounters. *Journal of applied psychology*, 92(4), 1177.
- [6] Kehoe, R. R., & Wright, P. M. (2013). The impact of high-performance human resource practices on employees' attitudes and behaviors. *Journal of management*, 39(2), 366-391.
- [7] Arijanto, A., & Taufik, M. (2017). Analysis of effect of organizational culture and organization commitment to performance of PT AisanNasmoco industry employees. *European Journal of Business and Management*, 9(3), 111-117.
- [8] Podsakoff, P. M., & MacKenzie, S. B. (2014). Impact of organizational citizenship behavior on organizational performance: A review and suggestions for future research. *Organizational Citizenship Behavior and Contextual Performance*, 133-151.
- [9] Morgan, D., & Zeffane, R. (2003). Employee involvement, organizational change and trust in management. *International journal of human resource management*, 14(1), 55-75.
- [10] Phipps, S. T., Prieto, L. C., & Ndinguri, E. N. (2013). Understanding the impact of employee involvement on organizational productivity: The moderating role of organizational commitment. *Journal of Organizational Culture, Communications and Conflict*, 17(2), 107.
- [11] Chughtai, A. A. (2008). Impact of job involvement on in-role job performance and organizational citizenship behaviour. *Journal of Behavioral and Applied Management*, 9(2), 169-183.
- [12] Tayo, E., & Adeyemi, A. (2012). Job involvement & organizational commitment as determinants of job performance among educational resource centre personal. *European Journal of Globalization and Development Research*, 5(1), 302-311.
- [13] Tran, H. Q., & Pham, N. T. B. (2019). Organizational learning as a moderator of the effect of employee participation on academic results: an empirical study in Vietnam. *The Learning Organization*.
- [14] Rizwan, M., Khan, D. J., & Saboor, F. (2011). Relationship of job involvement with employee performance: Moderating role of attitude. *European Journal of Business and Management*, 3(8), 77-85.
- [15] Singh, A., & Gupta, B. (2015). Job involvement, organizational commitment, professional commitment, and team commitment: A study of generational diversity. *Benchmarking: An International Journal*.
- [16] Kuye, L. O., & Sulaimon, A. A. H. (2011). Employee involvement in decision making and firms performance in the manufacturing sector in Nigeria. *Serbian journal of management*, 6(1), 1-15.
- [17] Marin-Garcia, J. A., & Bonavia, T. (2015). Relationship between employee involvement and lean manufacturing and its effect on performance in a rigid continuous process industry. *International Journal of Production Research*, 53(11), 3260-3275.
- [18] Hermawati, A., & Mas, N. (2017). Mediation effect of quality of work life, job involvement, and organizational citizenship behavior in relationship between transglobal leadership to employee performance. *International Journal of Law and Management*.
- [19] Groen, B. A., Wouters, M. J., & Wilderom, C. P. (2017). Employee participation, performance metrics, and job performance: A survey study based on self-determination theory. *Management accounting research*, 36, 51-66.
- [20] Lu, Y., & Pan, T. (2019). The effect of employee participation in enterprise social media on their job performance. *IEEE Access*, 7, 137528-137542.



- [21] Looor-Zambrano, H.Y., Santos-Roldán, L. and Palacios-Florencio, B., 2022. Relationship CSR and employee commitment: Mediating effects of internal motivation and trust. *European Research on Management and Business Economics*, 28(2), 100185.
- [22] Tuffour, J.K., Gali, A.M. and Tuffour, M.K., 2022. Managerial leadership style and employee commitment: Evidence from the financial sector. *Global Business Review*, 23(3), 543-560.
- [23] Rabiul, M.K., Patwary, A.K., Mohamed, A.E. and Rashid, H.O., 2022. Leadership styles, psychological factors, and employee commitment to service quality in the hotel industry. *Journal of Quality Assurance in Hospitality & Tourism*, 23(4), 853-881.
- [24] Babo, R., Dey, N. and Ashour, A.S. eds., 2021. *Workgroups eAssessment: Planning, implementing and analysing frameworks*. Springer.
- [25] Majumder, S., Chowdhury, S., Dey, N. and Santosh, K.C., 2022. *Balance Your Work-Life: Personal Interactive Web-Interface*.
- [26] Majumder, S. and Dey, N., 2022. Knowledge Management in Various Sectors. In *AI-empowered Knowledge Management*. Springer, Singapore (pp. 37-61).
- [27] Majumder, S. and Dey, N., 2022. Knowledge Management System. In *AI-empowered Knowledge Management*. Springer, Singapore (pp. 63-84).

# Importance of Reverse Logistics on Green Supply Chain Performance: An Empirical Study

Saniye Yıldırım Özmutlu<sup>1</sup>, Korhan Arun<sup>2</sup>

<sup>1</sup>Vocational School of Social Sciences, Tekirdag Namik Kemal University, Tekirdag, Turkey

<sup>2</sup>Faculty of Economics and Administrative Sciences, Tekirdag Namik Kemal University, Tekirdag, Turkey

<sup>1</sup>saniyeyildirim@nku.edu.tr, <sup>2</sup>karun@nku.edu.tr

**Abstract**—This study aims to determine the impacts of reverse logistics on green supply chain performance. Reverse logistics is an indispensable part of green supply chains. However, the direction and quantity of the effects of reverse logistics on green supply chain performance have not been researched. Our population universe is packaging companies in Turkey. Data is collected through online survey software from each senior manager of the 437 packaging companies. The data is analyzed by path analysis, formed to test the hypothesis, depending on the variance-based structural equation model. The results show that reverse logistics significantly affects green supply chain performance. Moreover and interestingly, despite the common belief in the logistics literature, the productivity dimension is found to be more effective than the cost concerns of the packaging firms in Turkey.

**Keywords** - reverse logistics, green supply chain, packaging companies, performance

## I. INTRODUCTION

The General Union Environment Action Programme of 2020 tackles waste management for recycling, remanufacturing, and reuse [1]. These activities are integral to reverse logistics and product returns management [2]. However, the environmental dimensions of sustainable logistics must be performed with explicit recognition of the economic objects of the firm [3]. Sustainable business needs reverse logistics, even though this logistic function has been present within a few businesses for longer than

we would expect. So, companies should constantly follow their green supply chain performance. Thus, this paper will research the relationship between reverse logistics and green supply chain performance.

Reverse logistics can be described as “the process of planning, implementing and controlling backward flows of raw materials, in process inventory, packaging, and finished goods, from a manufacturing, distribution or use point to the point of recovery or proper disposal” [4,5]. In the literature, simultaneously forward and reverse supply chains are also known as closed-loop supply chains (CLSC) [6]. Reverse logistics has two critical duties for the general supply chain. First is covering customers’ demands for creating value-added processes; second, reverse logistics tries to collect the waste products (called return products) from customers and determine the best ways to account for them [7].

Corporate environmental programs can source competitive advantage [8]. Moreover, reverse logistics is facilitated by the drivers such as green logistics and manufacturing systems. So, they are strictly bounded together. Thus, in the case of green supply chains, improvements in controlling customer returns and reducing waste flows improve the performance indexes significantly [9]. However, environmental issues in logistics are minor but expanding [10]. So, studying the effects of reverse logistics on green

logistics performance has gained more importance.

## II. HYPOTHESES DEVELOPMENT

Reliability is crucial for supply chain systems since their complexity level makes them susceptible to various possible fault sources [9]. However, reverse logistics forecasting is more complicated. So, difficult forecasting decreases the reliability and, thus, the performance of the whole/green supply chains. Furthermore, other differences between reverse logistics from the forward logistics are Many to one transportation, Product quality not uniform, Product packaging often damaged, Destination/routing unclear, Exception driven, Disposition not clear, Pricing dependent on many factors, Speed often not considered a priority, Reverse costs less directly visible, Inventory management not consistent, Product lifecycle issues more complex, Negotiation complicated by additional considerations, Marketing complicated by several factors, Visibility of process less transparent [11]. These differences are directly affecting the green supply chain.

Most important factors in reverse logistics are communications, costs; customer support; environmental, formalization; timing of operations; and top-management support [12]. Depending on these factors, Lambert et al. [13] proposed organizing reverse logistics as seven steps: Coordinating system; Gatekeeping; Collection; Sorting; Processing or Treatment; Information System; and Disposal or Expedition System.

A green supply chain is a form of a supply chain that is environmentally sustainable, created through environmentally sustainable practices, and complies with governmental environmental regulations [14]. Moreover, green supply chains ensure pollution reduction and minimize waste

from resources along the supply chains. Green supply chains also involve marketing view that highlight “green” image of the companies [15].

**H1:** Reverse logistics significantly and positively affects Green Supply Chain Performance

In order to test hypotheses, the structural equation model was used in this study (Fig.1). Fig.1 illustrates the relationship between reverse logistics and the performance of the green supply chain.

## III. METHODOLOGY

The data is analyzed using IBM AMOS Structural Equation Modeling (SEM). SEM is one of the statistical tools widely used in social science research. The primary advantage of SEM is that it allows assessment of fit between model and data [16,17]. In the study performed ( $\chi^2$ : 81.053,  $df$ : 30,  $\chi^2/df$ : 2, 702, GFI: 0.973, NFI: 0.966, CFI: 0.978, RMR: 0.013, RMSEA: 0.054) it was observed that there was a concordance between the model and the data. The secondary advantage of SEM is its ability to model relationships between multiple dependent and independent variables. Also, this method allows calculations by recognizing the existence of a causal relationship between latent variables [18]

### A. Data and Sample

The research universe comprises senior managers of approximately 1400 packaging companies operating in the Thrace region of Turkey between 2021 and 2022. The research sample comprises randomly selected senior managers of 985 packaging business firms in the Thrace region. The study’s sample size was created using calculations based on the sample table developed by Israel in 2013.

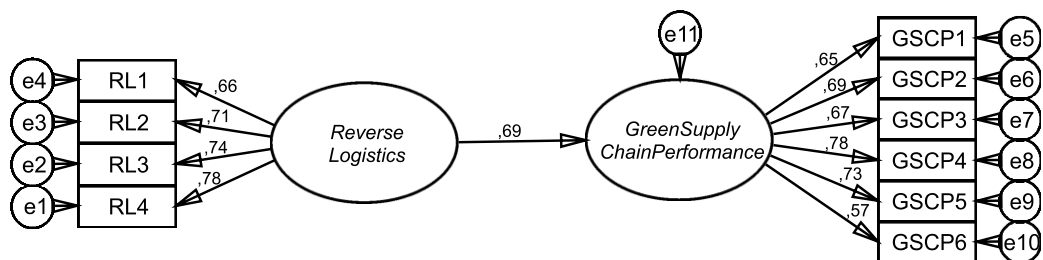

Figure 1. Reverse logistics and green supply chain performance relationship SEM model.

The assumption of normal size supports our required sample size according to the calculation tool for the sample size with a 95% confidence interval and  $\pm 5\%$  margin of error [19]. Of the 985 questionnaires distributed, 437 were returned and the sample size was supported for normal distribution and found suitable for analysis with a response rate of 44.5%. Questionnaires were collected by online application from the managers of packaging companies operating in the Thrace region of Turkey between April 2021 and June 2022. One senior manager from each company was reached. The first part of the research questionnaire contains the administrator's basic information like age, gender, and educational status. The second part of the study questionnaire contains ten questions about variable items. Data were collected by using a 5-point Likert-type scale.

#### B. Descriptive Analysis

According to the descriptive analysis, it was seen that 206 managers were between the ages of 26-35 (47.1%), and 155 managers were between the ages of 36-45 (35.5%) among the top managers in the companies covered by the research. It was noted that the majority (300 people, 68.6%) of those in senior management positions in the companies targeted by the research were men. It is seen that 283 (66.8%) of the managers included in the research have undergraduate education.

#### C. Measures

We used costs, asset management, customer service, and productivity items to measure reverse logistics performance [20].

We used green-focused sales and business volume, cost, profit/net revenue, customer satisfaction, on-time delivery, and product and service quality to measure green supply chain performance [21].

Variance based structural equation modeling is used to test the hypothesis. The model's standardized regression coefficient is displayed in Table I. The reverse logistics performance has a large and favorable impact on the green supply chain (0.686), as shown in Table I. More clearly, every one-point increase in the reverse logistics performance increases the green supply chain performance by 0.686 points.

Squared Multiple Correlation analysis shows that reverse logistics explains nearly 50% (0.470) of the green supply chain performance.

## IV. DISCUSSION

Reverse logistics is an indispensable aspect of sustainable, thus green supply chains [22,23]. However, the literature is unclear to what extent reverse logistics and various recovery operations are efficient and effective [22]. Our results show that reverse logistics can explain nearly fifty percent of firms' green supply chain performance. Moreover, the standardized regression coefficients in the structural path model show that the effect of reverse logistics is 0.686. More clearly, every one-point increase in reverse logistics can increase the green supply chain performance by 0.686. This number is significant because it implies a significant effect of reverse logistics.

This result is supported by much other research [24–26]. However, their research did not include direct vectorial effects of reverse logistics on the performance of green supply chains. Moreover, many topics used interchangeably with reverse logistics have not been adequately investigated, like reuse, remanufacturing and reuse, disassembly and design, recycling, and waste management [27,28]. As a result, our measurement for reverse logistics also brings a holistic approach.

Our measurement for reverse logistics has costs, asset management, customer service, and productivity dimensions. As can be seen from Fig.1, the less effective dimension for the reverse logistics costs (0.66); on the other hand, the most effective dimension is productivity (0.78). The asset management dimension impacts reverse logistics by 0.71 and customer service impacts by 0.74. These results also show that cost is a least effective factor in reverse logistics, contrary to the common thought in the logistics literature. This is an important conclusion of our study that firms should think about productivity, customer needs, and asset management (in order) to have effective reverse logistics. So, despite some authors' findings, our research shows essential factors rather than economic order quantity-based systems [29,30].

TABLE I. STANDARDIZED REGRESSION WEIGHTS: (GROUP NUMBER 1 - DEFAULT MODEL).

Variables	S.E.	C.R.	P	Estimate
GreenSupply_ChainPerformance <--- Reverse_Logistics	0.044	11.818	***	0.686

## V. CONCLUSION

This study investigates the effect of reverse logistics on the green supply chain performance in packaging companies in Turkey. The result shows that reverse logistics explains fifty percent of the green supply chain performance by 0.686. Moreover, it is found that the most important dimension on reverse logistics is productivity in the packaging sector despite the common thought of the cost-based approaches. Therefore, firms should aim more productive by the effective reverse logistics. As a result, our hypothesis is supported that reverse logistics play very important role in the green supply chain performance.

This paper also has some limitations. First, the data is collected as cross-sectional. Thus, the causality relationships should be repeated as longitudinal study. Second, data is collected from packaging companies. For other sectors, reverse logistics and end-life products may have different significance. Third, antecedents of reverse logistics can be different in other sectors and countries.

## REFERENCES

[1] European Commission & Directorate-General for Environment. (2014). *General Union environment action programme to 2020: Living well, within the limits of our planet*. Publications Office.

[2] Manzini, R., & Gamberini, R. (2008). Design, Management and Control of Logistic Distribution Systems. In V. Kordic (Ed.), *Supply Chain*. I-Tech Education and Publishing.

[3] Carter, C. R., & Rogers, D. S. (2008). A framework of sustainable supply chain management: Moving toward new theory. *International Journal of Physical Distribution & Logistics Management*, 38(5), 360–387.

[4] Rogers, D. S., & Tibben-Lembke, R. S. (1999). *Going backwards: Reverse logistics trends and practices*. Reverse Logistics Executive Council.

[5] Rubio, S., Chamorro, A., & Miranda, F. J. (2008). Characteristics of the research on reverse logistics (1995–2005). *International Journal of Production Research*, 46(4), 1099–1120.

[6] Govindan, K., & Soleimani, H. (2017). A review of reverse logistics and closed-loop supply chains: A Journal of Cleaner Production focus. *Journal of Cleaner Production*, 142, 371–384.

[7] Khor, K., & Udin, Z. (2012). Impact of Reverse Logistics Product Disposition towards Business Performance in Malaysian E&E Companies. *Journal of Supply Chain and Customer Relationship Management*, 1–19.

[8] Menon, A., & Menon, A. (1997). Enviropreneurial Marketing Strategy: The Emergence of Corporate Environmentalism as Market Strategy. *Journal of Marketing*, 61(1), 51–67.

[9] Achillas, C. (2019). *Green supply chain management*. Routledge, Taylor & Francis Group.

[10] Murphy, P. R., & Poist, R. F. (2003). Green perspectives and practices: A “comparative logistics” study. *Supply Chain Management: An International Journal*, 8(2), 122–131.

[11] Lembke, R., & Rogers, D. (2002). Differences between Forward and Reverse Logistics in a retail environment. *Supply Chain Management: An International Journal*, 7, 271–282.

[12] R. Huscroft, J., T. Hazen, B., J. Hall, D., B. Skipper, J., & B. Hanna, J. (2013). Reverse logistics: Past research, current management issues, and future directions. *The International Journal of Logistics Management*, 24(3), 304–327.

[13] Lambert, S., Riopel, D., & Abdul-Kader, W. (2011). A reverse logistics decisions conceptual framework. *Computers & Industrial Engineering*, 61(3), 561–581.

[14] Green, K. W., Zelbst, P. J., Meacham, J., & Bhadauria, V. S. (2012). Green supply chain management practices: Impact on performance. *Supply Chain Management: An International Journal*, 17(3), 290–305.

[15] Kumar, R. G., Murali, R., & Anand, S. (2019). Effect of internal supply chain drivers on green supply chain management attributes. *International Journal of Business Performance and Supply Chain Modelling*, 10(4), 323.

[16] Byrne, B. M. (2010). *Structural Equation Modeling with AMOS Basic Concepts, Applications, and Programming*. Routledge.

[17] Hancock, G. R. (1997). Structural Equation Modeling Methods of Hypothesis Testing of Latent Variable Means. *Measurement and Evaluation in Counseling and Development*, 30(2), 91–105.

[18] Hair, J. F., Babin, B. J., Anderson, R. E., & Black, W. C. (2019). *Multivariate data analysis*.

[19] Israel, G. D. (2013). *Determining sample size 1*. University of Florida.

[20] Chaves, G. de L. D., Giuriatto, N. T., & Ferreira, K. A. (2020). Reverse logistics performance measures: A survey of Brazilian companies. *Brazilian Journal of Operations & Production Management*, 17(2), 1–18.

[21] Chowdhury, M. M. H., & Quaddus, M. (2017). Supply chain resilience: Conceptualization and scale development using dynamic capability theory.

- International Journal of Production Economics*, 188, 185–204.
- [22] Khan, S. A. R. (Ed.). (2020). *Global perspectives on green business administration and sustainable supply chain management*. Business Science Reference.
- [23] Sarkis, J., & Zhu, Q. (2018). Environmental sustainability and production: Taking the road less travelled. *International Journal of Production Research*, 56(1–2), 743–759.
- [24] Aghazadeh, S. (2008). The success of reverse logistics in supporting the environment: The case of the computer industry. *International Journal of Environment and Sustainable Development*, 7.
- [25] Blanchard, D. (2007, April 10). *Supply Chains Also Work In Reverse*. Available at: <https://www.industryweek.com/supply-chain/planning-forecasting/article/21954433/supply-chains-also-work-in-reverse>
- [26] Hanna, M., & Newman, W. R. (2007). *Integrated operations management: A supply chain perspective (2nd ed)*. Thomson/South-Western.
- [27] Rezaei, J. (2015). A Systematic Review of Multi-criteria Decision-making Applications in Reverse Logistics. *Transportation Research Procedia*, 10, 766–776.
- [28] Rezaei, J., van Roekel, W. S., & Tavasszy, L. (2018). Measuring the relative importance of the logistics performance index indicators using Best Worst Method. *Transport Policy*, 68, 158–169.
- [29] Bazan, E., Jaber, M. Y., & Zaroni, S. (2016). A review of mathematical inventory models for reverse logistics and the future of its modeling: An environmental perspective. *Applied Mathematical Modelling*, 40(5), 4151–4178.
- [30] Condeixa, L. D., Silva, P., Moah, D., Farias, B., & Leiras, A. (2022). Evaluating cost impacts on reverse logistics using an Economic Order Quantity (EOQ) model with environmental and social considerations. *Central European Journal of Operations Research*, 30(3), 921–940.



# Nature Prefers Sustainable Structures: Implications for Large-Scale Political Self-Organization

Jacob C.W. Billings<sup>1</sup>

<sup>1</sup>Independent Researcher, USA

<sup>1</sup>billings.jacob@gmail.com

**Abstract**—At this moment in history, humanity has the unique capability to hold a conversation, with all of her members, in real time. While we (currently) tend to utilize global telecommunications technologies to affect directed information exchange between a “rich-club” minority and a lay majority; it is within our capability to establish an equitable “global public-sphere”, wherein we might decide, collectively, what constitutes an intersubjective version of “the good”. The following paper formalizes the assertion that analyzing the semantic content of public-sphere conversation can reveal existing, as well as improvements to, humanity’s organizational norms.

**Keywords** - Managing Knowledge for Global and Collaborative Innovations, Big data and knowledge extraction, Cognitive knowledge, Global Public Sphere

## I. INTRODUCTION

“Action, the only activity that goes on directly between men without the intermediary of things or matter, corresponds to the human condition of plurality” - Arendt [1].

“Since all knowledge and every choice is directed toward some good, let us discuss what is in our view the aim of politics, i.e., the highest good attainable by action” - Aristotle [2].

Several global issues face humanity. The increasing trend towards global pandemics, including COVID-19, forces us to restructure our societal norms. Anthropogenic climate change compels us to reconfigure our economies. While chronic poverty, war, and famine serve as ongoing reminders that, “until we are all free, we

are none of us free,” in the face of these global issues, how can humanity move towards more sustainable ways of life? My approach to this humanistic question provides a democratic answer, one rooted in the biology of complex self-assembly.

## II. NATURE SEEKING ALPHA

According to the Second law of Thermodynamics: the configuration of mass/energy in the universe tends towards disorder. The fact of the eventual entropic death of the universe begs the question: “How did complex systems, like people and politics, get here in the first place?” The omni-directional expansion of the universe requires that complex systems emerged through a bit of circumstantial luck: entropy was at a minimum at the time of the “Big Bang.” But, even while the dawn of time was unexpectedly information-rich (low-entropy), the total energy of the universe, crammed together into a singularity, made things too hot to sustain much patterned differentiation. Large scale systems, like galaxies, and fragile complexes like ecosystems and politics, were unable to stabilize until the universe expanded and cooled. Furthermore, because the distribution of matter and energy in the universe was never homogeneous everywhere, inclusions of thermodynamic disequilibria allowed systems to locally self-assemble along the energy gradient of free expansion in space-time.

Formally, Prigogine defines the process of natural self-assembly as the minimization of the local rate of entropy production [3,4]. Put another way: at any point in time, natural systems may either thermally randomize, or self-



assemble, into patterned structures that channel thermodynamic gradients into useful work, like internal homeostasis, and population growth. Aristotle reminds us that the self-assembly of societies into disorder-minimizing structures is called “politics” [2]. It is convenient to refer to “the good” - that goal for which all self-assembled systems perform work - using the variable  $\alpha$ .

### III. POLITICS IN THE ABSTRACT

Arendt [1] characterizes politics as the essential definition of a people. To better address the pluralistic aspects of politics, I specify populations  $P$  as composed of individuals,  $p$ . Moreover, I refer to groups of people of size  $n$  as  $P_n$ .

Of course, all politics is local. Furthermore, every person in the population,  $p \in P$ , performs work to gain a subjectively defined  $\alpha | p$ . To better conceptualize the individualistic aspect of politics, I define the equation:

$$x(p) = \alpha | p - \varepsilon. \quad (1)$$

where  $x(p)$  is work performed by an  $p$ , and where  $\varepsilon$  indicates the generation of entropy. To define a group-level “good”  $\alpha | P_n$ , we have the union:

$$x(P_n) = \bigcup_{p \in P_n} x(p) = \alpha | P_n - \varepsilon. \quad (2)$$

Focusing on work as a means to understand politics offers a useful frame of reference. For instance, the upper limit on any group size  $|P_n|$  is established by the physical limits on  $x(P_n)$  to connect people. As an example, for any  $P_n$  utilizing exclusively oral communication,  $|P_n|$  is generally limited to the few hundred persons of a tribe [5]. Inscribed communication enabled  $|P_n|$  to expand to the size of city-states. Meanwhile, the capitalization of printing presses is believed to have ushered in the age of the modern nation-state [6].

### IV. OF POLITICAL NETWORKS

If politics is described in terms of a graph,  $G$ , where the  $p$  are nodes and the  $x(p)$  constitute directed edges, then the  $\alpha$  are the apparent structures that emerge among the set of  $P_{0 \leq n \leq N}$

nodes via the set of  $x(P_n)$  edges. By way of example, consider Locke’s “state of nature”. In this condition, people seek  $\alpha$  through  $x(P_n)$  that are uniformly accessible to all people, i.e., through spoken language [7,8]. Quantitatively, this state corresponds to a  $G$ , in which there exists a relatively uniform count of the number and the type of  $x(p)$  edges stemming from any node,  $p$ . By contrast, some novel  $x$ , like printing presses, possess a high utility, yet low availability. Such technologies encourage  $P$  to organize around hubs in which, otherwise separate,  $P_n$  communicate with one another via those few  $p$ , who have access to the novel  $x$ . Quantitatively, these kinds of networks are termed “small-world” networks. Hubs of small-world networks are defined as having many more  $x(p)$  edges than expected from the average [9].

While the modern constitutional republic emerged around the constraints of high-utility/low-availability forms of  $x$  [10], this style of politics is problematic because information is always lost when filtered through communication bottlenecks. Furthermore, well-connected hubs in  $P$  may form what’s known as a “rich club” network, wherein the hubs preferentially connect to one another [11]. Consolidation of political power within a rich club tends to widen differences in  $\alpha | p$  between richly and poorly connected  $p \in P_n$  [12].

### V. EVOLVING POLITICAL DYNAMICS

Fortunately, many of humanity’s current communications technologies boast high-utility and high-availability. For instance, approximately half of the global population has regular access to the internet [13]. And that number is only set to increase, as cellular and satellite relays eventually connect all of us into a global public sphere [14]. This infrastructure provides the necessary backbone through which we might finally just ask one another to define a mutually beneficial  $\alpha | P$  towards which we all might work.

One of the key tools used to handle massive quantities of unstructured data is the “knowledge database”  $K_b$ , composed of elementary “subject predicate object” statements [15]. This technology supports popular services, such as search, recommendation, and text completion. Computationally, statements are saved as triples,

containing an emitter,  $k_e$ , a receiver,  $k_r$ , as well as a directed predicate,  $y(k_e, k_r)$ . Given this conception, ensembles of triples form a “knowledge graph”,  $K_G$ , in which nodes are an  $k \in K$ , and edges are an  $y \in Y$ . The set  $[K, Y]$  is termed an “ontology”.

Much as the conception of politics in terms of  $G$  presents the observation of political realities,  $\alpha | G$ ; the conception of knowledge (about  $G$ ) in terms of  $K$  permits the elucidation of political ideals,  $\beta | K$ . Interestingly, for the proper subset  $P \subset K$ , there is the relationship  $\alpha | P \in \beta | K$  [16]. Put another way, a thorough-going transcription of human knowledge contains, within it, a population-level sense of “the good”. Moreover, machine-learning applied to an accessible (and complete) digital public sphere can drive the discovery of optimal political assemblies.

A facile example of optimizing political assemblies simply observes latent political groups,  $P_n \in P$ , who emerge as clusters in  $K$ , as connected via shared edges,  $y$ . A slightly more complicated clustering follows from the methods of [17], wherein  $P_n$  are derived from the principal components of an adjacency matrix formed by the many  $y$  of  $K$ .

Furthermore, a clustering over the nodes in (graphs such as)  $K$  can be seen as an analysis of topological objects in dimension zero [18]. Higher order topological features describe, for example, directed paths - chains of logical syllogisms - in dimension 1. It is also possible to reformulate  $K$  in a way that is amenable to Topological Data Analysis (TDA). Typically, TDA imposes a filtration over weighted edges to detect stable topological features. One way to reformulate  $K$  into a weighted single-layer graph is by assigning a single number to the multiple edges of  $y$  that connect pairs of emitter and receiver nodes. Then, filtering out weaker and weaker links, it is possible to visualize, for instance, the most stable link(s) connecting two  $P_n$  groups who hold opposing views on a topic. By tuning how  $K$  is collapsed into a single layer network through, e.g., selectively adding/ablating  $y$  w.r.t. semantic objects of interest, one may actively discern how contingent are structures in  $K$  w.r.t. select semantic objects.

A wide range of such machine-learning approaches are available to elucidate the intrinsic structure of social networks,  $\beta | K$ , so-as-to elucidate more optimal political unions,  $\alpha | G$ . Such approaches constitute a ripe domain wherein we might encourage the evolution of our political dynamics.

## VI. DISCUSSION AND FUTURE DIRECTIONS

It is clear that, possessed of a will to do thusly, humanity could - in mere weeks - recruit off-the-shelf technologies to connect nearly every man woman and child into a global conversation. From a systems-level perspective, provisioning more efficient methods of internal communications improves the capacity for bodies to maintain homeodynamic stability over large scales. From a sociological perspective, provisioning a global public sphere to discuss intersubjective values lays the foundation for political decisions that recruit our collective capabilities to meet and exceed our needs.

However, the will to act as a well-functioning global civil society currently eludes us. This impasse imposes upon the research community an obligation to better organize extant (digital) conversations to reify, for any lay observer, the existence of a nescient collective will.

The present manuscript details how the format of the knowledge database may be recruited to organize free-form semantic text in a way that visualizes likely collective sentiments. In the immediate future, researchers could work along two paths that: 1) assemble and share an expanding knowledge database of intersubjective values; and 2) analyze the associated knowledge graph to visualize potential areas of collective accord. It would be very interesting to see the emergence of an interdisciplinary empirical political science that directly queries humanity towards the elucidation of political norms.

## VII. CONCLUSIONS

Being itself a natural system, humanity will naturally prefer to evolve towards greater and greater homeodynamic stability. But while the physical process of spontaneous structural self-assembly is relatively slow and uncertain, we can actively take part in humanity’s ongoing efforts to establish healthy, sustainable, and productive civil-society by building infrastructure in support of a vibrant global public sphere. Indeed, humanity is in a unique position to sustain, in real

time, a dialogue that equally includes all of her members. Certainly “perfection” and “eutopia” are mythical goals – no system holds the knowledge of, and the capacity to negotiate all potential issues. None-the-less, humanity maximizes her knowledge about the issues that might exist, and she increases her wellspring of creative solutions for those issues, by assembling a union of perspectives from all persons. Drawing political decisions from a more complete space of global perspectives should afford many improvements to each individual’s quality of life.

#### ACKNOWLEDGMENT

The author would like to acknowledge Emory’s Mind, Brain, and Culture Institute (Atlanta, USA) for their assistance framing cross-disciplinary examinations of natural emergent systems.

#### REFERENCES

- [1] Arendt, H. (1958). *The human condition*. University of Chicago Press.
- [2] Ostwald, M. (1964). *Nicomachean ethics*.
- [3] Prigogine, I. (1993). Time, structure and fluctuations. *Nobel Lectures in Chemistry 1971-1980*, 263–285.
- [4] Hidalgo, C. (2015). *Why information grows: The evolution of order, from atoms to economies*. Basic Books.
- [5] Dunbar, R. I. (1993). Coevolution of neocortical size, group size and language in humans. *Behavioral and Brain Sciences*, 16(4), 681–694.
- [6] Anderson, B. (2006). *Imagined communities: Reflections on the origin and spread of nationalism*. Verso Books.
- [7] Locke, J. (1988). *Two treatises of government*. Cambridge University Press.
- [8] Stout, D., & Chaminade, T. (2012). Stone tools, language and the brain in human evolution. *Philosophical Transactions of the Royal Society B: Biological Sciences*, 367(1585), 75–87.
- [9] Wang, X. F., & Chen, G. (2003). Complex networks: Small-world, scale-free and beyond. *IEEE Circuits and Systems Magazine*, 3(1), 6–20.
- [10] Harari, Y. N. (2015). *Sapiens: A Brief History of Humankind*. Harper.
- [11] Csigi, M., Korösi, A., Bíró, J., Heszberger, Z., Malkov, Y., & Gulyás, A. (2017). Geometric explanation of the rich-club phenomenon in complex networks. *Scientific Reports*, 7 (1).
- [12] Piketty, T., & Goldhammer, A. (2014). *Capital in the twenty-first century*. Harvard University Press.
- [13] Rosling, H., Rönnlund, A., & Rosling, O. (2018). *Factfulness: Ten reasons we’re wrong about the world—and why things are better than you think*. Flatiron Books.
- [14] Volkmer, I. (2014). *The Global Public Sphere*. Polity Press.
- [15] Hogan, A., et al. (2020). Knowledge Graphs. *ACM Computing Surveys (CSUR)*, 54(4), 1-37.
- [16] Rasetti, M. (2017). The “Life Machine”: A Quantum Metaphor for Living Matter. *International Journal of Theoretical Physics*, 56(1), 145–167.
- [17] *The Computational Democracy Project*. Available at: <https://github.com/compdemocracy/>.
- [18] Billings, J., Saggat, M., Hlinka, J., Keilholz, S., & Petri, G. (2021). Simplicial and topological descriptions of human brain dynamics. *Network Neuroscience*, 5(2): 549–568.

# Mediating Role of Knowledge Management Process in Turning Intellectual Capital and Social Capital into Innovation Capability and Sustainable Performance of SMEs

Anh Tuan Pham<sup>1</sup>, Quoc Trung Pham<sup>2</sup>

<sup>1</sup>Ho Chi Minh City University of Food Industry, Vietnam, Ho Chi Minh City, Vietnam

<sup>2</sup>Ho Chi Minh City University of Technology (VNU-HCM), HCMC, Vietnam

<sup>1</sup>tuanpanh@hufi.edu.vn, <sup>2</sup>pqtrung@hcmut.edu.vn

**Abstract**—Research on knowledge management (KM) has created the perception that the most basic and important thing for enterprises is the exploitation of external knowledge sources to be able to fill the knowledge gap in enterprise. However, this understanding has not been adequately researched both theory and experiment in the context of SMEs. Therefore, this study aims to analyze the mediating role of the KM process in turning intellectual capital (IC) and social capital (SOC) into innovation capability (INC) and sustainable performance (SUP) in SMEs. The contribution of this study is, first of all, to outline this gap on the basis of a review of previous studies. Then, the study proposes a model that focuses on the mediating role of the KM process in turning IC and SOC into INC and SUP to fill this theoretical gap. Finally, based on the proposed model, three specific issues of significant importance toward SMEs are discussed: (1) the role of open innovation in the relationship between IC and SOC for KM; (2) the relationship between KM, INC, and SUP; (3) the relationship between INC and SUP, and the mediating role of INC in the relationship between KM and SUP.

**Keywords** - intellectual capital, social capital, knowledge management and sustainable performance

## I. INTRODUCTION

KM is considered a systematic foundation for storing, measuring, and optimizing an organization's knowledge economy [1]. In which, IC is a collection of intangible assets that

create value for businesses [2]. In the context of SMEs, internal knowledge prevails to focus on developing innovative activities, while knowledge resources and the most valuable resources may be outside the organization [1]. Therefore, in addition to handling inside developed intellectual assets, enterprises also need to pay attention to acquiring and exploiting knowledge from the outside. This is an opportunity for an organization to develop new value through value co-creation between the enterprise and its stakeholders. This is a new trend to help integrate internal and external inputs to develop new products and make the KM process more efficient, which is open innovation [3]. Due to limited resources, SMEs are also more vulnerable to global crises, with COVID-19 having a particularly harmful impact on them. Post-COVID-19, they face many challenges to sustainability in this fragile new environment. In this situation, research by Tran & Huynh [4] has shown that SOC has a significant impact on the resilience of SMEs in the context of the COVID-19 pandemic. However, while extensive research has often focused on the three-component framework of IC (human capital, structured capital, and relational capital), SOC has received little attention [5].

Management of SMEs based on knowledge, innovation, and OP perspectives is an emerging research topic. Studies simultaneously consider relationships between KM, innovation, and OP

are very rare, mostly done in developed countries, and there are very few studies that focus on different type of SMEs [6]. Besides, as part of their social responsibility, organizations need to adopt environmentally friendly approaches and advanced technology to achieve SUP [7]. However, there is little research on the relationship between KM and SUP [8]. Regarding corporate social responsibility, previous studies hardly explored the business-related aspect of SMEs [9]. On the other hand, the combination of approaches between IC and KM for OP is expected to be more successful for future studies [10]. Therefore, to fill this gap, this study aims to identify the mediating role of the KM process in turning IC and SOC into INC and SUP in SMEs in Vietnam.

The structure of the article is organized as follows: (1) Introduction; (2) Literature review and research model; (3) Research methods; (4) Research results; and finally, (5) Discussion and conclusions.

## II. LITERATURE REVIEW AND RESEARCH MODEL

### A. Literature review

#### 1) Intellectual capital

IC also known as knowledge assets, is an important intangible resource for businesses to create knowledge [11]. The most common and standard classification of IC consists of three main components: human capital (HC), structured capital (SC), and relational capital (RC) that have become the foundation for the development and measurement of IC [12]. In which, the knowledge asset of an organization consists of two main components: HC and SC, which is the soul of innovation [13]. Specifically, HC refers to members of an organization and their knowledge, skills, motivations, attitudes, and educational level; and SC includes “all the repositories of non-human knowledge” within the organization [14]. In addition, RC refers to the value of an organization’s relationships with other members of its business community [15]. From here, this study divides IC into two parts: internal IC (IIC) includes HC and SC; and external IC (EIC) is RC.

#### 2) Social capital

Regarding the SOC of enterprise, it is defined as the aggregate of enterprise resources, existing in relationships including leadership network, external network of enterprise, and internal network of enterprise [16]. Through social

relationships, it is possible to stimulate and facilitate knowledge activities of both the giver and the recipient [17]. In the post-COVID-19 context, SMEs are facing many difficulties to survive and develop sustainably. In this context, by exploring enterprise SOC as a resource to enhance post-pandemic resilience [18].

#### 3) KM process

KM is the systematic and organized use of an organization’s intellectual power to achieve efficiency, secure competitive advantage, and encourage innovation [19]. KM process is a systematic approach to acquire, share, and apply knowledge in processes to improve OP [20].

#### 4) Innovation capability

INC is defined as “an enterprise’s ability to apply collective knowledge, skills, and resources to innovative activities related to new products, services, processes or management systems, marketing or work organization, in order to create added value for enterprises or stakeholders” [21].

#### 5) Open innovation

Open innovation is “the intentional use of knowledge flows inside and outside the enterprise to promote internal innovation and open markets for external innovation use respectively. The open innovation model assumes that enterprises can and should use external ideas, as well as internal ideas to approach the market, as well as when enterprises want to improve their technology” [22].

#### 6) Sustainable performance

OP is the ability of an organization to access and process its various resources to achieve its stated objectives [23]. OP is considered based on two aspects: financial performance and non-financial performance [24]. In addition, [25] highlighted the role and importance of organizations having to behave responsibly towards society rather than being responsible for the environment in order to satisfy their economic goals. Therefore, SUP in this study is considered from the following three aspects: financial performance (FP), non-financial performance (NFP), and environmental performance (EP).

#### 7) Small and medium enterprise

There is no universal definition of SME across countries. Besides, SMEs can be identified by different measurement criteria such as number of employees, revenue, asset value,

etc. However, this study used staff numbers in the study design to facilitate data collection.

In Vietnam, SME is an abbreviation for micro, small, and medium-sized enterprises. In which, micro enterprises have no more than 10 employees, small enterprises with no more than 50 employees (trade, services) or not more than 100 employees (other fields), and medium enterprises with no more than 100 employees (trade and services) or not more than 200 employees (other fields).

## B. Research hypothesis

### 1) *Impact of IIC on KAC*

In the SME context, the capability, qualifications, and experience of HC reflect their knowledge base and contribute greatly to their absorptive capability [26]. Besides, SC also affects the acquisition and exploitation of knowledge in the organization. These are knowledge resources within the organization and owned by the organization [25]. Through the KM process, HC provides input for the creation, application, and transfer of newly acquired knowledge and support the renewal of a dynamic resource base [27]. Thence, hypothesis H1 is stated as follows:

H1: IIC has a positive effect on KAC

### 2) *Impact of IIC on KSH*

Starting from the employees in the enterprise, using hands-on skills, experience, and know-how as an object, it builds an internal KM framework including knowledge problems, IT, and knowledge community based on the transformation of tacit knowledge in the enterprise, as well as related incentive mechanisms and control mechanisms. Such a system makes the tacit knowledge of individuals in the enterprise shared with each other, makes shared knowledge into explicit knowledge, makes explicit knowledge an asset, and turn knowledge of assets into income [28]. Thence, hypothesis H2 is stated as follows:

H2: IIC has a positive effect on KSH

### 3) *Impact of IIC on KAP*

KM aims to create, code, and share knowledge within the organization and shift the focus from process to practice [29], facilitating effective internal knowledge flows within established communication networks can positively affect an organization's ability to absorb, share, and then apply knowledge for commercial purposes. Therefore, if an

organization increases KAC and application it in practice, the organization will be more successful [30]. Thence, hypothesis H3 is stated as follows:

H3: IIC has a positive effect on KAP

### 4) *Impact of EIC on KAC*

The more organizations interact with each other, the more likely to generate new knowledge and to help enhance INC. Collaboration with external partners such as customers can help enterprises deploy existing knowledge and thereby, create value [31]. Co-creation emphasizes the customer's role in both value creation and the development process of new or existing services. The proximity of SMEs to customers enables them to acquire knowledge more directly and faster than large enterprises [32]. Thence, hypothesis H4 is stated as follows:

H4: EIC has a positive effect on KAC

### 5) *Impact of EIC on KSH*

Externally-oriented enterprises often have many opportunities to obtain information related to the business environment and promote innovation activities. Business outcomes are related to knowledge exchange with inside or outside the organization and KSH definitely makes a difference in the performance of an organization [33]. Therefore, if employees have a culture of sharing and conveying valuable information within the organization, the goals of the enterprise will be realized and organizations can solve problems through creative solutions based on knowledge shared among individuals [34]. Thence, hypothesis H5 is stated as follows:

H5: EIC has a positive effect on KSH

### 6) *Impact of EIC on KAP*

Enterprises obtain a significant portion of their knowledge from external sources (customers, suppliers, ...) [35]. The strength of these relationships play an important role in RC for a enterprise's competitive advantage, that is, after collecting knowledge to fill the knowledge gap in enterprises, the new knowledge will be applied in the organization. KAP means making knowledge more active and relevant for the organization in creating value [35]. Thence, hypothesis H6 is stated as follows:

H6: EIC has a positive effect on KAP

### 7) *The impact of SOC on KAC*

SOC improves the cooperation process and the learning capability of the parties, the ability to adapt, absorb, and integrate resources, creating

the basis for the collaborative advantage needed to co-create value [36]. Different social relationships can generate new ideas and mobilize enterprise resources [37]. SOC benefits sales centers by providing them with access to knowledge [37]. Thence, hypothesis H7 is stated as follows:

H7: SOC has a positive effect on KAC

8) *The impact of SOC on KSH*

SOC helps to enhance an organization's capability to disseminate knowledge resources within the organization by facilitating knowledge processes to take place [38]. KSH related to the social needs of individuals. An important element of the cognitive dimension of SOC is the shared goals among team members. Through common goals can motivate team members to share knowledge and cooperate together [39]. Thence, hypothesis H8 is stated as follows:

H8: SOC has a positive effect on KSH

9) *The impact of SOC on KAP*

Knowledge transfer is an important benefit of SOC [39], and knowledge is only useful if it is transferred through the organization, integrated with other knowledge, and applied in practice [37]. KAP can be achieved through sharing among colleagues. This is a particularly relevant process, since the foundation of an organization's competitive advantage lies not in the knowledge itself but in its application [40]. Thence, hypothesis H9 is stated as follows:

H9: SOC has a positive effect on KAP

10) *The impact of KAC on INC*

The participation of enterprises in innovation cooperation with various external parties enriches their knowledge base and develops a better ability to assimilate and exploit external knowledge, thereby, enabling them to integrate dynamic capabilities [41]. These external knowledge sources are integrated with tacit and explicit knowledge inside the organization, which will be useful for improving INC [13]. Thence, hypothesis H10 is stated as follows:

H10: KAC has a positive effect on INC

11) *The impact of KAC on SUP*

KAC has yielded significant results such as: leading to competitive advantage, increased sales, new product development, and adjustments and improvements in innovation processes. Indeed, the acquisition of technology from outside has a positive effect on the

efficiency of firms in Taiwan [42]. The resource-based view (RBV) emphasizes that such resources can help shape strategies to achieve sustainability goals [43]. Thence, hypothesis H11 is stated as follows:

H11: KAC has a positive effect on SUP

12) *Impact of KSH on INC*

One of the important issues of organizational learning is KSH [33]. Through appropriate knowledge distribution and sharing, organizations can improve INC [13]. In addition, previous studies have shown that IC and KSH can stimulate both innovative and creative activities [44]. Thence, hypothesis H12 is stated as follows:

H12: KSH has a positive effect on INC

13) *Impact of KSH on SUP*

KSH positively affects OP and the quality of decisions made within the organization [33]. By disseminating knowledge among stakeholders, organizational capabilities can be improved and essential processes such as problem solving, decision making, leadership, effectiveness, and innovation can be improved. KSH facilitates the achievement of a knowledge strategy and increase the organization's SUP [45]. Thence, hypothesis H13 is stated as follows:

H13: KSH has a positive effect on SUP

14) *Impact of KAP on INC*

Knowledge stored only in the head of each individual, it is only when shared and used externally, new acquired knowledge can be successfully converted into new products, technologies, and services to meet customer needs and improve the innovation performance. This is because in the process of KAP, new knowledge will be created and thereby, helping to improve innovation capability [17]. Thence, hypothesis H14 is stated as follows:

H14: KAP has a positive effect on INC

15) *Impact of KAP on SUP*

KAP can be understood as the implementation of the necessary knowledge in the processes and activities of the organization to achieve the organization's knowledge strategy and SUP [45]. From a knowledge-based view (KBV), [31] argued that KAP is the basis for achieving competitive advantage and is associated with OP. The RBV believes that the existing resources of enterprises are the basis for enterprises to develop and strengthen their

capabilities through continuous collaborative learning. These resources can be used to implement value creation strategies which can lead to a sustainable competitive advantage [46]. Thence, hypothesis H15 is stated as follows:

H15: KAP has a positive effect on SUP

16) *Impact of INC on SUP*

SUP is at the heart of the innovation strategy [47]. According to RBV, businesses possess an innovative strategy, a flexible organizational structure, a culture of innovation, technological capabilities, effective customer and supplier relationships, and innovative products that the non-owned enterprises will achieve higher. Thence, hypothesis H16 is stated as follows:

H16: INC has a positive effect on SUP

C. *Proposed research model*

The above hypotheses can be summarized in the following research model (Fig.1).

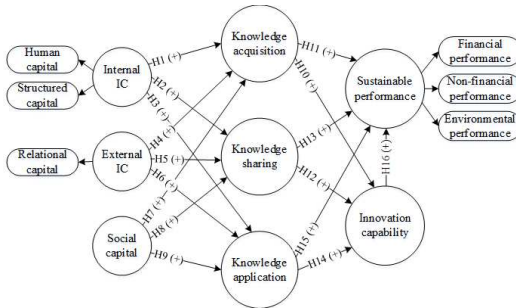

Figure 1. Proposed research model

III. RESEARCH METHODS

A. *Measures*

The formation of the scales is inherited from previous studies, specifically, (1) the IC scale is inherited from [48]. In there: IIC includes HC (4 variables) and SC (6 variables), and EIC is RC (4 variables); (2) the SOC scale (4 variables) is inherited from [16] [36]; (3) the KM process scale includes: KAC (3 variables), KSH (3 variables), and KAP (4 variables) are inherited from [49]; (4) the INC scale (6 variables) is inherited from [50]; and (5) SUP scale includes: FP (4 variables) and NFP (4 variables) inherited from [12], and EP (5 variables) inherited from [51]. To ensure the content validity of the scale, a qualitative study through face-to-face discussion with 11 managers at SMEs in Vietnam. Then, edit the wording to suit the research context. The scale used in the study is a 5-point Likert scale.

B. *Data collection*

The questionnaires were sent to selected SMEs on the basis of convenience. This survey was conducted in September 2022, 454 questionnaires were collected back, after removing 131 invalid questionnaires, remaining 323 valid questionnaires, so the valid response rate reaches 71.15%. Data were analyzed by SPSS v20 and AMOS v22 software to evaluate the reliability of the scale, exploratory factor analysis (EFA), confirmatory factor analysis (CFA) and structural equation modeling analysis (SEM) to test the hypotheses.

IV. DATA ANALYSIS AND RESULTS

A. *Evaluate the reliability of the scale*

The Cronbach's Alpha test is evaluated based on Cronbach's Alpha if Item Deleted, along with the Corrected Item-Total Correlation. If a measure has Corrected Item-Total Correlation  $\geq 0.3$  then that variable is qualified [52].

TABLE I. RELIABILITY ANALYSIS RESULTS

Scales	Observed variables	Cronbach's alpha
HC	HC1, HC2	0.989
SC	SC1, SC2, SC4	0.983
RC	RC1, RC2, RC3, RC4	0.872
SOC	SOC1, SOC2, SOC3, SOC4	0.887
KAC	KAC1, KAC2, KAC3	0.809
KSH	KSH1, KSH2, KSH3	0.865
KAP	KAP1, KAP2, KAP3	0.897
INC	INC1, INC2, INC3, INC4, INC5	0.918
FP	FP1, FP2, FP3, FP4	0.820
NFP	NFP1, NFP2, NFP3	0.808
EP	EP1, EP2, EP3, EP4, EP5	0.913

The results show that the scales all have Cronbach's Alpha coefficient  $> 0.6$  and corrected item-total correlation coefficients are all greater than 0.3, so the scales of the factor groups are reliable and continue to be used for factor analysis.

B. *Exploratory factor analysis for independent and dependent variables*

Using Principal axis factoring method and Promax angle rotation to find out representative factors for the scales. KMO coefficient is used to test the suitability of factor analysis [52]. EFA analysis results show that the remaining 39 observed variables all have factor loading coefficients greater than 0.5 and grouped into 11 factors ready for CFA and SEM analysis.



### C. Confirmatory factor analysis (CFA)

To increase the relevance of the research data, based on the Modification Indices (MI) of the variables to adjust the fit of the model. The results after adjustment shows that the current model is consistent with the research data (CMIN/df=1.557; GFI=0.884; TLI=0.960; CFI=0.965; RMSEA=0.042; P=0.000).

The convergence and discrimination analysis results of the variables in the overall model show that the CR values of the variables are all higher than 0.7. and the AVE values of the unidirectional scales are all greater than 0.5, thus the scales of the variables all ensure convergence [52]. Besides, the square root of AVE is larger than the correlations between latent variables and the MSV value is smaller than AVE, thus distinctiveness is guaranteed. The next step, convert the scale model to a research model to conduct SEM testing.

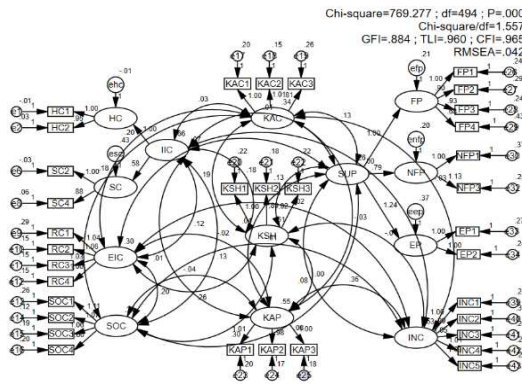

Figure 2. Scale model

### D. Structural equation modeling (SEM)

The SEM analysis results show that the analytical model is consistent with the research data (CMIN/df=1.546; GFI=0.883; TLI=0.961; CFI=0.965; RMSEA=0.041, p=0.000)

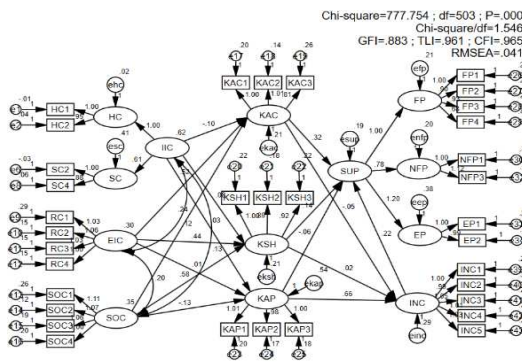

Figure 3. Standardized SEM model

Standardized Regression Weights are summarized in Table II. This study also examines the mediating role of INC in the relationship between KM and SUP. Bootstrap test results with 95% reliability show that the Sig. value of KAP is  $0.007 < 0.05$ , so there exists an indirect relationship from KAP to SUP. Therefore, there is a mediating relationship from KAP to SUP.

TABLE II. STANDARDIZED REGRESSION WEIGHTS

Parameter	Estimate	Lower	Upper	P	Result
KSH <- EIC	.436	.214	.646	.007	Accepted
KAP <- EIC	.010	-.216	.274	.884	Rejected
KSH <- SOC	.577	.412	.789	.002	Accepted
KAP <- SOC	-.129	-.354	.067	.222	Rejected
KAC <- IIC	-.099	-.218	-.017	.006	Accepted
KSH <- IIC	.081	-.017	.184	.092	Rejected
KAC <- EIC	.518	.361	.732	.003	Accepted
KAC <- SOC	.242	.076	.401	.006	Accepted
KAP <- IIC	.032	-.091	.167	.489	Rejected
INC <- KSH	.022	-.101	.122	.690	Rejected
INC <- KAP	.656	.537	.773	.005	Accepted
INC <- KAC	-.051	-.212	.104	.525	Rejected
SUP <- KAP	-.056	-.187	.080	.403	Rejected
SUP <- KSH	.141	.027	.260	.014	Accepted
SUP <- KAC	.316	.173	.484	.004	Accepted
SUP <- INC	.220	.091	.366	.004	Accepted

### E. Results discussion

This study is concerned with both theoretical and practical aspects. Theoretically, this study proposes a research model for empirical studies to link IC and SOC with INC, as well as SUP of SMEs through the KM process. Following are the results from the SEM approach.

The results show that IC and SOC have a positive effect on KM, thereby leading to improved INC and SUP. Besides, the results also show that INC plays a full mediator role in the relationship between KM and SUP. From a practical perspective, the relationship between IC, SOC, KM, INC, and SUP can provide clues as to how SMEs can promote KAC, KSH, and KAP to Integrating knowledge inside and outside the enterprise to improve the INC and maintain the SUP of the enterprise.

The results also show that INC plays a full mediating role in the relationship between KM, specifically KAP and SUP. This result is consistent with the study of [64] said that KM has no direct effect on business performance of SMEs except through innovation. This implies that without innovation, SMEs may not be able to achieve better business performance.

## V. CONCLUSIONS

This study concludes that, IC (internal and external) and SOC contribute to improving the INC and SUP of SMEs through the KM process (KAC, KSH, and KAP). This is attributed to the organization's ability to conceptualize the strategic importance of intellectual resources, as it provides a comprehensive understanding of both the internal and external intellectual resources present in the workforce, organizational structure or network relationships.

Future research directions may consider these variables in developing countries like Vietnam or consider the direct impact of IC and SOC on INC, as well as SUP, or focus on a particular industry or sector of the SMEs.

## REFERENCES

- [1] Salma, N. (2021). The effects of intellectual capital and knowledge management processes on dynamic capabilities of the organizations. *Journal of Contemporary Issues in Business and Government*, 27(3), 2154-2162.
- [2] Jardon, C. M., & Martinez-Cobas, X. (2021). Measuring intellectual capital with financial data. *PLoS one*, 16(5), e0249989.
- [3] Bigliardi, B., Ferraro, G., Filippelli, S., & Galati, F. (2020). The influence of open innovation on firm performance. *International Journal of Engineering Business Management*, 12, 1847979020969545.
- [4] Ngoc, T. M., & Vy, H. D. B. Exploring the internal drivers of SMEs' resilience: The case of Ho Chi Minh City SMEs in the context of Covid-19.
- [5] Asiaei, K., & Jusoh, R. (2015). A multidimensional view of intellectual capital: the impact on organizational performance. *Management decision*.
- [6] Kurniawati, A., Wiratmadja, I. I., Sunaryo, I., & Samadhi, T. A. (2019, April). Relationship among knowledge management, innovation, and performance: A systematic literature review. In *2019 IEEE 6th International Conference on Industrial Engineering and Applications (ICIEA)* (pp. 700-704).
- [7] Zhu, Q., Zou, F., & Zhang, P. (2019). The role of innovation for performance improvement through corporate social responsibility practices among small and medium-sized suppliers in China. *Corporate Social Responsibility and Environmental Management*, 26(2), 341-350.
- [8] Demir, A., Budur, T., Omer, H. M., & Heshmati, A. (2021). Links between knowledge management and organisational sustainability: does the ISO 9001 certification have an effect?. *Knowledge management research & practice*, 1-14.
- [9] Watto, W. A., Manurung, D. T. H., Saputra, K. A. K., & Mustafa, S. G. (2020). Corporate social responsibility and firm financial performance: A case of SME's sector in Pakistan. *International Journal of Environmental, Sustainability, and Social Science*, 1(2), 62-74.
- [10] Hussinki, H., Ritala, P., Vanhala, M., & Kianto, A. (2017). Intellectual capital, knowledge management practices and firm performance. *Journal of intellectual capital*.
- [11] Paoloni, M., Coluccia, D., Fontana, S., & Solimene, S. (2020). Knowledge management, intellectual capital and entrepreneurship: a structured literature review. *Journal of Knowledge Management*, 24(8), 1797-1818.
- [12] Wang, Z., Wang, N., & Liang, H. (2014). Knowledge sharing, intellectual capital and firm performance. *Management Decision*, 52(2), 230-258.
- [13] Akram, K., Siddiqui, S. H., Nawaz, M. A., Ghauri, T. A., & Cheema, A. K. H. (2011). Role of knowledge management to bring innovation: an integrated approach. *Cell*, 92(333), 6183035.
- [14] Inkinen, H. (2015). Review of empirical research on intellectual capital and firm performance. *Journal of Intellectual capital*, 16(3), 518-565.
- [15] Chen, J., Zhao, X., & Wang, Y. (2015). A new measurement of intellectual capital and its impact on innovation performance in an open innovation paradigm. *International Journal of Technology Management*, 67(1), 1-25.
- [16] Yang, J., Alejandro, T. G. B., & Boles, J. S. (2011). The role of social capital and knowledge. *Journal of Business and Industrial Marketing*, 26(3), 152-161.
- [17] Cepeda-Carrion, I., Martelo-Landroguez, S., Leal-Rodríguez, A. L., & Leal-Millán, A. (2017). Critical processes of knowledge management: An approach toward the creation of customer value. *European Research on Management and Business Economics*, 23(1), 1-7.
- [18] Polyviou, M., Croxton, K. L., & Knemeyer, A. M. (2020). Resilience of medium-sized firms to supply chain disruptions: the role of internal social capital. *International Journal of Operations & Production Management*, 40(1), 68-91.
- [19] Serban, A. M., & Luan, J. (2002). Overview of knowledge management. *New directions for institutional research*, 2002(113), 5-16.
- [20] Augier, M., & Teece, D. J. (2009). Dynamic capabilities and the role of managers in business strategy and economic performance. *Organization science*, 20(2), 410-421.
- [21] Hogan, S. J., Soutar, G. N., McColl-Kennedy, J. R., & Sweeney, J. C. (2011). Reconceptualizing professional service firm innovation capability: Scale development. *Industrial marketing management*, 40(8), 1264-1273.
- [22] Chesbrough, H. W. (2003). *Open innovation: The new imperative for creating and profiting from technology*. Harvard Business Press.
- [23] Sangiorgi, D., & Siboni, B. (2017). The disclosure of intellectual capital in Italian universities: What has been done and what should be done. *Journal of intellectual capital*.
- [24] Obeidat, B. Y., Tarhini, A., Masa'deh, R. E., & Aqqad, N. O. (2017). The impact of intellectual capital on innovation via the mediating role of knowledge management: a structural equation modelling approach. *International Journal of Knowledge Management Studies*, 8(3-4), 273-298.
- [25] Yusliza, M. Y., Yong, J. Y., Tanveer, M. I., Ramayah, T., Faezah, J. N., & Muhammad, Z. (2020). A structural model of the impact of green intellectual

- capital on sustainable performance. *Journal of Cleaner Production*, 249, 119334.
- [26] Valentim, L., Lisboa, J. V., & Franco, M. (2016). Knowledge management practices and absorptive capacity in small and medium-sized enterprises: is there really a linkage?. *R&D Management*, 46(4), 711-725.
- [27] Singh, B., & Rao, M. K. (2016). Examining the effects of intellectual capital on dynamic capabilities in emerging economy context: knowledge management processes as a mediator. *Emerging Economy Studies*, 2(1), 110-128.
- [28] Jin-Feng, W., Ming-Yan, C., Li-Jie, F., & Jun-Ju, Y. (2017). The construction of enterprise tacit knowledge sharing stimulation system oriented to employee individual. *Procedia engineering*, 174, 289-300.
- [29] Mohajan, H. K. (2017). The Roles of Knowledge Management for the Development of Organizations. *Journal of Scientific Achievements*, 2(2), 1-27.
- [30] Shafiei Nikabadi, M. (2022). Framework for knowledge management processes in supply chain. *Iranian Journal of Information Processing and Management*, 28(3), 611-642.
- [31] Ode, E., Rigby, J., & Proudlove, N. (2017). How knowledge management processes increase customer value and firm performance through value co-creation. Available at SSRN 3148453.
- [32] Yew Wong, K., & Aspinwall, E. (2004). Characterizing knowledge management in the small business environment. *Journal of Knowledge management*, 8(3), 44-61.
- [33] Heisig, P., Suraj, O. A., Kianto, A., Kemboi, C., Arrau, G. P., & Easa, N. F. (2016). Knowledge management and business performance: global experts' views on future research needs. *Journal of Knowledge Management*, 20(6), 1169-1198.
- [34] L. Sanders Jones, J., & Linderman, K. (2014). Process management, innovation and efficiency performance: The moderating effect of competitive intensity. *Business Process Management Journal*, 20(2), 335-358.
- [35] Yip, M. W., Ng, A. H. H., & Din, S. B. (2012). Knowledge management activities in small and medium enterprises/industries: a conceptual framework. In *2012 International Conference on Innovation and Information Management (ICIM 2012) IPCSIT* (Vol. 36, pp. 23-26).
- [36] Alves, H., & Edvardsson, B. (2019, December). Understanding Collaborative Advantage and Value Co-Creation Through Social Capital Theory. In *ICICKM 2019 16th International Conference on Intellectual Capital Knowledge Management & Organisational Learning* (p. 33). Academic Conferences and publishing limited.
- [37] Alejandro, T. B., Yang, J., & Boles, J. S. (2011). The role of social capital and knowledge transfer in selling center performance. *Journal of Business & Industrial Marketing*, 26(3), 152-161.
- [38] Yang, J., Brashear Alejandro, T. G., & Boles, J. S. (2011). The role of social capital and knowledge transfer in selling center performance. *Journal of Business & Industrial Marketing*, 26(3), 152-161.
- [39] Inkpen, A. C., & Tsang, E. W. (2005). Social capital, networks, and knowledge transfer. *Academy of management review*, 30(1), 146-165.
- [40] Alavi, M., & Leidner, D. E. (2001). Knowledge management and knowledge management systems: Conceptual foundations and research issues. *MIS quarterly*, 107-136.
- [41] Khan, A., Tao, M., & Li, C. (2022). Knowledge absorption capacity's efficacy to enhance innovation performance through big data analytics and digital platform capability. *Journal of Innovation & Knowledge*, 7(3), 100201.
- [42] Hung, K. P., & Chou, C. (2013). The impact of open innovation on firm performance: The moderating effects of internal R&D and environmental turbulence. *Technovation*, 33(10-11), 368-380.
- [43] Madhani, P. M. (2009). Resource based view (RBV) of competitive advantages: Importance, issues and implications. *KHOJ Journal of Indian Management Research and Practices*, 1(2), 2-12.
- [44] Shujahat, M., Sousa, M. J., Hussain, S., Nawaz, F., Wang, M., & Umer, M. (2019). Translating the impact of knowledge management processes into knowledge-based innovation: The neglected and mediating role of knowledge-worker productivity. *Journal of Business Research*, 94, 442-450.
- [45] Kordab, M., Raudeliūnienė, J., & Meidutė-Kavaliauskienė, I. (2020). Mediating role of knowledge management in the relationship between organizational learning and sustainable organizational performance. *Sustainability*, 12(23), 10061.
- [46] Egbetokun, A. A. (2015). Interactive learning and firm-level capabilities in latecomer settings: The Nigerian manufacturing industry. *Technological Forecasting and Social Change*, 99, 231-241.
- [47] Hang, Y., Sarfraz, M., Khalid, R., Ozturk, I., & Tariq, J. (2022). Does corporate social responsibility and green product innovation boost organizational performance? a moderated mediation model of competitive advantage and green trust. *Economic Research-Ekonomska Istraživanja*, 35(1), 5379-5399.
- [48] Khaliq, M., Bontis, N., Shaari, J. A. N. B., Yaacob, M. R., & Ngah, R. (2018). Intellectual capital and organisational performance in Malaysian knowledge-intensive SMEs. *International Journal of Learning and Intellectual Capital*, 15(1), 20-36.
- [49] Balasubramanian, S., Al-Ahbab, S., & Sreejith, S. (2020). Knowledge management processes and performance: The impact of ownership of public sector organizations. *International Journal of Public Sector Management*, 33(1), 1-21.
- [50] Calantone, R. J., Cavusgil, S. T., & Zhao, Y. (2002). Learning orientation, firm innovation capability, and firm performance. *Industrial marketing management*, 31(6), 515-524.
- [51] Laosirihongthong, T., Adebajo, D., & Tan, K. C. (2013). Green supply chain management practices and performance. *Industrial Management & Data Systems*, 113(8), 1088-1109.
- [52] Hair, J., Black, W. C., Babin, B. J., & Anderson, R. E. (2010). *Multivariate data analysis* (7th ed.). Upper saddle River, NJ: Pearson Education.

# How Did the Slovak Labour Market Change during the Coronavirus Crisis?

Lucia Bartková<sup>1</sup>

<sup>1</sup>Institute of managerial systems, Faculty of Economics, Marej Bel University, Poprad, Slovak Republic

<sup>1</sup>lucia.bartkova@umb.sk

**Abstract**—The COVID-19 pandemic caused the unprecedented disruption in our lives. Due to high infection of the novel coronavirus, many people had to stay at home, governments set lockdowns and employees were not able to go to work. Many companies rearranged their way of work and employees, when it was possible, shifted to the home office. It involves purchase of working equipment, mostly information technologies. These changes provoked also changes in the values of both – employees and employers. Employees require to be rewarded for the performance, not for the time spent in the work, and employers require results regardless the place where an employee is working. To study these changes will be very useful also in connection with current increase of inflation and rising costs of energy.

**Keywords** – COVID-19, remote work, home office, telework

## I. INTRODUCTION

The disease COVID-19 is a respiratory disease caused by the virus SARS-CoV-2 (Severe Acute Respiratory Syndrome Coronavirus 2) originally discovered in December 2019 [1]. The first case of infection caused by the novel coronavirus was discovered in Wuhan City, Hubei Province, China [2]. The virus is primarily spread from person to person through droplets from infected people by coughing, sneezing or during conversation [3].

At the end of February 2020, the disease COVID-19 spread rapidly throughout the world [4]. The World Health Organization declared a global pandemic of COVID-19 on March 11, 2020 [5]. In an effort to slow the spread of the

COVID-19 disease, the World Health Organization and the Red Cross have advised people to follow strict measures for their own safety, which under normal circumstances slow the spread of other viral diseases [6]. The basic recommendations were extending the time for washing hands, wearing masks, covering the cough, and sneezing, frequent disinfection of surfaces, and limiting hand and face contact [7].

In addition to these measures at the level of individuals, several measures were taken at the level of companies and states. Within the lockdown, businesses were closed, mobility of people was limited, employees worked from home as much as possible, curfews were introduced, mass events were cancelled. Due to the spread of the virus, employees of many companies in Slovakia were forced to work from home and banned from personal meetings, what had a huge impact on the entire society, the economy and also the labour market. We analysed the situation and changes in the Slovak labour market through secondary research of information published on the largest Slovak job portal Profesia.sk.

## II. THE CORONAVIRUS PANDEMIC IN SLOVAKIA

Slovakia took the first measures connected with COVID-19 already on January 27, 2020. At that time, the disease was not yet found in Slovakia, but in Europe e.g., France had already started reporting the first cases of infection [8]. On March 6, the first case of COVID-19 was confirmed in the Slovak Republic [9]. After the confirmation of the occurrence of the disease

COVID-19 in Slovakia, the adoption of measures gained speed. Sport, cultural and public events were banned, schools and airports began to be closed [10,11].

Effective from March 16, retail sales and the sale of services were prohibited for 14 days, with some exceptions (food stores, medical devices, drugstores, fuel stores, newsstands, stores of feed and supplies for animals, including veterinary clinics, telecommunications operators, postal, banking and insurance services and operations of online shops and delivery services). Public catering establishments and fast-food stalls remained open, but it was forbidden to eat in their premises, it was possible only outside their establishments [12]. Another measure was the restriction of the use of taxi services only for the transport of goods, not people. The Crisis Team of the Slovak Republic recommended covering the breathing ways with protective masks [13].

At the end of March 2020, several stores that had been closed until then (optician(s), garden centres, haberdasher(s), ironmonger(s) and others) opened, but the hygienic conditions in the shops were tightened. It became mandatory to wear protective masks in store, to use disinfection or protective gloves, which the businesses themselves were obliged to provide. It was mandatory to ensure two-meter distances between people waiting in lines. The number of people in the store was also limited: one person per 25 square meters. Also, the time in shops was defined preferentially for people over 65 years old as a result of the fact that they represent the most endangered group [14].

At the end of April 2020, other stores were opened: shops and service operations up to 300 m<sup>2</sup>, public catering operations with food delivery through a window, outdoor sports fields without changing rooms, toilets, and the public; long-term accommodation facilities without shared meals, outdoor markets, car dealerships and bazaars [15].

As the first wave of the COVID-19 disease was successfully managed, other establishments (short-term accommodation, hairdressers and barbershops, manicures and pedicures, cosmetics and solariums, outdoor tourist attractions, taxi services with separated space for clients and without air conditioning, religious services and weddings, all commercial establishments regardless of size except shopping centers, public catering with eating on outdoor terraces, rehabilitation facilities providing only dry

procedures, museums, galleries, libraries and exhibition halls). However, strict hygiene measures remained in force (face masks, hand disinfection, two-meter distances between customers, 25 square meters per customer [16].

During the summer of 2020, the situation looked promising, but the onset of the second wave at the end of 2020 and the beginning of 2021 delayed all plans. Many employees have thus returned to a full or partial home office. Already during September 2021, the number of positive cases increased, and the virus also appeared in several companies. But it was positive that during the summer companies had the opportunity to develop pandemic plans and prepare for various scenarios. Many of them were thus able to adapt to the current situation and function. They later used the experience to manage the third wave, the immigration of Ukrainians fleeing the military conflict, and price increases due to inflation in the second half of 2022.

### III. CHANGES IN THE SLOVAK LABOUR MARKET AS A RESULT OF THE CORONAVIRUS CRISIS

The first changes in the Slovak labour market occurred already in March 2020. Due to the spread of the virus, employees of many companies in Slovakia were forced to home office (also called “remote work”). It is a type of work that is not tied to the employer’s workplace, but to another agreed place of work, most often the residence (household) of the employee, throughout the working hours. The Labour Code of Slovak Republic defines and distinguishes work from home (home office) and domestic work or telework. Home office work is work performed occasionally or under extraordinary circumstances with the consent of the employers or by agreement with them at home or at a place other than the usual place of work, provided that the type of work performed by the employee in accordance with the employment contract and the job description allows it (§ 52, Section 5 of Act no. 311/2001 Coll. The Labour Code in its current version – hereinafter “the Labour Code”).

Domestic work and telework in accordance with § 52 Section 1 of the Labour Code is work performed by an employee for the employer under the conditions agreed in the employment contract at home or at another agreed place (domestic work) or work according to the conditions agreed in the employment contract at

home or at another agreed place using information technology (teleworking) during working hours, which the employee most often schedules themselves.

The mandatory transition to work from home brought several necessary requirements, especially in connection with the purchase of information technology. Employees either brought computers and laptops home from work, or it was necessary to purchase them. It was also necessary to equip a workplace at home with a camera, headphones, etc. and to acquire a software or application for electronic communication or conference calls.

However, the coronavirus crisis did not only affect businesses and existing employees, but also the applicants themselves. Those who were currently in the notice period, for example, could have feared that they would end up completely without work and income for a certain period when the interviews were postponed. Here, information technology and video interviews helped, too. These also helped the companies themselves, as they have eliminated the risk that candidates whose interviews have been postponed will find work elsewhere in the meantime [17].

At the end of March 2020, over 200 Slovak employers asked the government to change the Labour Code. The change was supposed to enable the simultaneous work from home and at the same time receiving the benefit in case of treatment of a family member. An employee with children working from home could officially divide his time between work and caring for family members [18]. Until then, such a scenario was not possible under the law. The parents of the children thus only had the option of the benefit in case of treatment of a family member, but as a result, companies lost the necessary people. When the parents wanted to avoid this, but because of their children they could not work continuously for 8 hours a day, they had to help themselves by taking half a day of leave. In Slovakia, the so-called pandemic benefit in case of treatment of a family member was established, which enabled parents to stay at home for a long time with school-age children.

Working from home was the most common measure chosen by employers in Slovakia at the beginning of 2020. The highest share of employees with a home office was in information technology, the lowest in the hospitality and tourism [19]. The possibility to work from home

also appeared more often in job offers. However, it was rather a work bonus, the opportunity to work from home a few days a month, not a job offers in which the employee does not have to come to work at all [20].

In addition to the possibility to work from home, as part of other measures, companies have stopped business trips or modified the rules for the performance of work at the workplace. Job reduction or cancelling working hours were the last options. Some companies also adopted other, specific measures, such as testing employees for COVID-19 as a benefit, transferring employees to other projects, and increasing the level of management communication and employee awareness. Even though, for many employers the coronavirus crisis brought a reduction in sales, companies tried everything to avoid reducing salaries, rewards, or benefits. However, several were ready to proceed with reducing salaries or rewards at the management level, or for people who earn above a certain level. A frequent measure that also concerned ordinary employees was the recommendation or order to take a leave [21].

Meanwhile, the most companies have prepared a plan for employees to return to work if the pandemic situation improves. Among the basic measures was the provision of a higher hygiene standard as the use of masks in the interior, the use of gloves, and regular disinfection of the premises. Several employers planned to measure temperature or require testing for COVID-19. Employees were supposed to return to the office in groups, or according to schedules. However, some businesses continued to work from home and the return to the workplace was voluntary. At that time, companies stated that labour productivity with home office remained unchanged, or even increased [22].

Most employers started a gradual return to workplaces from June 2020. However, some employees continued to request to work from home and come to the workplace only exceptionally for meetings. Some of them were very satisfied with working at home, some were worried about their health. Workers of customer support worked more effectively from home because no one disturbed them. The situation was worse for merchants who lacked sales. Problems with working at home were also experienced by employees who had children and did not have good conditions for peaceful work at home. That

is why most employers have begun to think intensively about extending the benefit, when employees can also work from home a few days a month [23].

To cope with the first wave of the COVID-19 disease in Slovakia were prepared mainly companies that have parent or sister companies abroad, where the disease appeared earlier. Internal communication proved to be the most important factor in managing the crisis in companies - by intensifying top management communication, creating a central crisis team, or increasing support for managers, also through videos, podcasts, and various online communication tools [24].

The coronavirus first reduced the number of job opportunities on the Slovak labour market. The employers quickly adapted to the situation and in the summer of 2020, when the number of people infected with the coronavirus decreased, the situation improved. However, based on the analysis of the profesia.sk portal, it turned out that the average salary that employers state in offers fell by up to 6.7%. The drop in offered salaries was related to entire territory of Slovakia and was not affected by the required education either. Offered wages grew only in the IT and services industries. On the contrary, offers fell most significantly in the sectors of top management, trade, and telecommunications, especially for positions such as director of logistics, head of transport, operations manager, designer of communication networks or cashier [25].

Also, the second wave of the COVID-19 disease at the end of 2020 caused changes in the labour market. The number of job offers fell, especially in the travel, gastronomy and hotel sectors, but also customer support and administration. The job offer grew only in production [26].

The second wave was also associated with the start of home offices. As research has shown, 43% of companies said their employees are happier and more satisfied if they work from home. Many employees felt more secure, as they eliminated the inevitable meeting with strangers on the way to work or in offices. On the other hand, a quarter of the companies experienced more discomfort of employees. The biggest disadvantages were the absence of a team, unsuitable working conditions, fatigue and psychological problems, or disturbed work life balance, when people finish work in the

evenings. As many as 64% of respondents confirmed that their employees felt less connected to the collective. Companies thus defined new needs for education or development of corporate culture to improve the situation. People working in HR identified the area of self-management (time management, stress management, wellbeing) and the development of digital skills as priorities. It was also important to focus on communication, leadership and building interpersonal relationships [27].

Since it was expected that the second wave of the coronavirus crisis would last at least until the spring of another year, employers faced another challenge. Working from home was associated with new needs for self-development of employees, especially in the field of self-management, digital skills, communication and building interpersonal relationships, building the ability to be flexible and adapt to changes, developing cognitive skills (problem solving, creativity, flexible thinking) and language skills. Employees therefore expected that employers would accommodate them in meeting these needs, and some employers have already started providing a contribution to support working from home [28].

In March 2021, a year after the outbreak of the coronavirus crisis in Slovakia, the number of job offers stabilized [29]. There were even job offers offering the entire performance of work from home without the need to commute to the workplace. Such offers were mainly in the sectors of IT, telecommunications, translation, marketing, and journalism. The higher number of offers for telework was also complemented by the increased occurrence of offers in which employers offered the option of using the benefit of working from home few days in a week [30]. As of September 2021, the offer of telework has increased thirteenfold compared to 2019 [31].

On the other hand, as it follows from the analysis of secondary data, the majority of employees do not demand full remote work, rather they are in favour of partial or hybrid form [32]. Most employees feel that their work performance during the home office is the same or better than at the workplace. However, employees perceive the pitfalls of working from home.

In the research from August 2021, the majority of respondents stated that they have a problem to manage their work at home as part of a home office. Other problems were the inability

to concentrate, balancing family and work, creating a workspace or maintaining contact with colleagues. People who do not live alone pointed out the negatives of the home office the most. The biggest problem for employees was precisely the disturbance from other members of the household. On the contrary, the survey found that they had almost no problems with the new digital skills required and arranging meetings online. Workers had used to these things and could adapt to them. As the biggest help, the respondents mentioned particularly flexible working hours enabling to take into account also private needs. When working from home, the independence and trust of the company in solving tasks, suitable technical equipment, regular internal communication, or online education also helped to employees [33].

After a relatively good pandemic situation during the summer of 2021, there was a worsening again in the autumn and a lockdown was introduced again, which in practice meant closing stores and restricting the movement of people. Employers reacted to the current situation by slowing down the publication of job offers, but the numbers were more positive compared to the first and second waves. There were more job vacancies on the labour market than in previous years, even more than was usual in the pre-pandemic period [34].

While before the pandemic only a few companies offered their employees the option to work from home, two years during the pandemic changed the way most companies operate. Data from the largest job portal Profesia.sk shows that in 2022 the number of offers that offer job seekers partial remote work increased. In this case, the employers agree with the candidates how many days they will work at home and how much time they will spend in the office. A partial home office combines several benefits: flexibility, saves employees the time needed to move to the office, but at the same time does not deprive them of social contacts with colleagues. The share of job offers with a partial home office has been continuously growing since this period.

Some employers do not require the workers to perform their work in a designated location. Thus, employees can complete their tasks at home or at any chosen location. If they need to connect with colleagues, they can do it through the online environment. The offer of telework in Slovakia mostly concerns highly specialized IT positions and is also continuously growing [35].

Although the COVID-19 disease had only a mild course in Slovakia in the second half of 2022, other factors affected the economy and the labour market. The war in Ukraine affected Slovakia as an immediate neighbour with the arrival of many immigrants. The labour market thus came under pressure again. Most employers have intensified communication about aid to Ukraine for their workers. Data from the company Profesia.sk have already shown in the past that two years with the pandemic brought more information about mental health to companies. The horrors of war in Ukraine are another topic that has a large effect on the psyche of people in a short time. The current situation therefore motivates employers to intensify communication about mental health again [36].

Another event closely connected with the events in Ukraine is high inflation, which causes a worldwide increase in the prices of all commodities. Along with the rise in prices, salaries in Slovakia also rise slightly. The job portal Profesia.sk recorded an increase in the offered salaries by 9% compared to previous year. The number of job offers promising regular wage increases is also growing [37]. This is certainly positive for employees, as the COVID-19 pandemic in Slovakia has caused pressure to reduce salaries. Employers also limited the provision of bonuses to their employees during the coronavirus crisis. Currently, there is a shortage of applicants on the labour market, so employers, in addition to offering higher salaries and the promise of regular salary increases, also offer applicants various benefits. The offer of a financial bonus for employees who recommend a new person to the company has increased significantly. Slovak employers are more providing health-related benefits to employees, the so-called sick days. Also, the share of employees with above-standard health care, additional health insurance or wage compensation in case of incapacity for work is increasing. Many employers who were forced to reduce benefits in 2021 have already returned these options to their employees, for example, education, employee discounts, or company events. Other bonuses are e.g., employee parking spaces or drinks at the workplace for free [38].

The months with the pandemic and the ever-expanding home office have also increased the availability of flexible working hours. The growth of the job offers of this bonus can currently be related to high inflation and high energy prices when the natural desire of



companies to save is manifested. Since during the two years of COVID-19 pandemics they invested in the infrastructure for employees in their home working environment and most people like to work partially from home, enabling work from home saves energy in companies.

#### IV. CONCLUSION

After two years of living with the disease of COVID-19, we can conclude that the most significant change in the labour market in the Slovak Republic is the strengthening of work from home. The number of job offers with a home office option (a few days of work per month from home) gradually grew. There has also been a significant increase in interest in teleworking, what means that the employee performs all his work from home using telecommunication technologies and is not required to be present at the workplace at all.

As practice during the corona crisis showed, the work performance of employees working from home does not necessarily have to decrease. On the contrary, in certain cases (customer support, IT, marketing, translation), an employee can better concentrate on work in the privacy of his own home. In addition, since remote work saves time and effort for preparation and transfer to work, the employee can devote himself to work longer and more concentrated. Due to the fact that in many professions employees were forced to work from home at the beginning of the pandemic, which involved equipping the household with the necessary technology and furniture, today they can make full use of this investment. Employers, on the other hand, are aware of the benefits of working from home for employees, so they offer the opportunity to work at least part of the work from home as a convenient work benefit.

The pitfalls of working from home are primarily the laborious organization of working time, as well as social isolation and poor contact with the work team. Therefore, employees do not even require full telework, but require a partial home office, when they can work from home on certain days. They demand more freedom and flexibility from employers, also in working time, work organization and remuneration system in the sense of a greater focus on the result than on the time spent at work.

Although the fourth wave of the COVID-19 disease is not yet expected in Slovakia, since the

beginning of 2022, the war in Ukraine, which lies immediately next to Slovakia, has been resonating in society. During the coronavirus crisis, many employers understood the importance of the mental health of their employees and strengthened their internal communication and employee support, which they also used in the event of the war in Ukraine. They could thus quickly communicate their employees ways how to help and also provide work for people coming to Slovakia. Due to this, soon after the outbreak of the conflict, the job offers for Ukrainian citizens exceeded the actual demand.

In connection with inflation and rising prices, we can see a continuous increase in the offer of work through telework or partial home office in the labour market. In this case, the employee works completely or partially from home, which allows the company to organize work at the workplace to achieve the greatest possible energy savings.

Based on the above information, we can see that employers flexibly adapted to the situation during the coronavirus crisis, and the labour market and the economy in the Slovak Republic did not suffer significantly. On the other hand, other unpleasant situations such as the military conflict in Ukraine and the global rise in prices created additional pressure on Slovak companies. But as can be seen from the analysis of data on the labour market, even in this time the companies were able to adapt to the new situation and used the tools they built during the pandemic period to maintain jobs and even to increase salaries and provide employee bonuses. However, it is certainly necessary for companies to continue to monitor the situation both in the area of inflation and in the area of the COVID-19 disease and to be prepared for new problems and challenges that will arise in the future.

#### ACKNOWLEDGMENT

This contribution was supported by the project No. 1/0134/22, "Changes in consumer behavior due to the COVID-19 pandemic with intent to predict its development".

#### REFERENCES

- [1] Zhu, N. et al. (2020). A Novel Coronavirus from Patients with Pneumonia in China, 2019. *The New England Journal of Medicine*, 382, 727-733.
- [2] Li, Q. et al. (2020). Early transmission dynamics in Wuhan, China, of novel coronavirus-infected

- pneumonia. *The New England Journal of Medicine*, 382, 1199-1207.
- [3] Chukwuma N., Jin Z., & Karakhan, A. (2022). Safety and health management response to COVID-19 in the construction industry: A perspective of fieldworkers. *Process Safety and Environmental Protection*, 159, 477-488.
  - [4] WHO. (2020). *Coronavirus disease 2019 (COVID-19): Situation report - 36*. Available at: [https://www.who.int/docs/default-source/coronaviruse/situation-reports/20200225-sitrep-36-covid-19.pdf?sfvrsn=2791b4e0\\_2](https://www.who.int/docs/default-source/coronaviruse/situation-reports/20200225-sitrep-36-covid-19.pdf?sfvrsn=2791b4e0_2)
  - [5] WHO. (2020). *WHO Director-General's opening remarks at the media briefing on COVID-19 - 11 March 2020*. Available at: <https://www.who.int/director-general/speeches/detail/who-director-general-s-opening-remarks-at-the-media-briefing-on-covid-19--11-march-2020>
  - [6] Earle, M., Prusaczyk, E., Choma, B., & Calogero, R. (2021). Compliance with COVID-19 safety measures: A test of an objectification theory model. *Body Image*, 37, 6-13.
  - [7] Red Cross. (2020). COVID-19: *Safety tips for you*. Available at: <https://www.redcross.org/about-us/news-and-events/news/2020/coronavirus-safety-and-readiness-tips-for-you.html>
  - [8] Ministry of Health SR. (2020). *Slovensko prijíma opatrenia v súvislosti s novým koronavírusom 2019-nCoV*. Available at: <https://www.health.gov.sk/Clanok?premier-koronavirus-opatrenia>
  - [9] Ministry of Health SR. (2020). *Slovensko zaznamenalo prvý potvrdený prípad ochorenia COVID-19*. Available at: <https://www.health.gov.sk/Clanok?koronavirus-pripad-prvy-opatrenia>
  - [10] Ministry of Health SR. (2020). *COVID-19: Slovensko zakazuje športové, kultúrne a verejné podujatia, hlási 7 potvrdených prípadov*. Available at: <https://www.health.gov.sk/Clanok?covid-19-slovensko-zakazuje-sportove-kulturne-a-verejne-podujatia>
  - [11] Ministry of Health SR. (2020). *COVID-19: Krízový štáb zavádza prísne opatrenia, zatvárajú sa školy, letiská*. Available at: <https://www.health.gov.sk/Clanok?koronavirus-opatrenia-sprisnene>
  - [12] Ministry of Health SR. (2020). *COVID-19 (koronavírus): Vláda prijala mimoriadne opatrenia*. Available at: <https://www.health.gov.sk/Clanok?vlada-prijala-mimoriadne-opatrenia-15-3-2020>
  - [13] Ministry of Health SR. (2020). *COVID-19: Krízový štáb pokračuje v prísnych opatreniach*. Available at: <https://www.health.gov.sk/Clanok?krizovy-stab-pokracuje-v-opatreniach-17-3-2020>
  - [14] Ministry of Health SR. (2020). *COVID-19: Prísnejšie hygienické podmienky v obchodoch, viac prevádzok otvorených*. Available at: <https://www.health.gov.sk/Clanok?covid-19-prisnejsie-hygienicke-podmienky-v-obchodoch>
  - [15] Ministry of Health SR. (2020). *COVID-19: Ústredný krízový štáb schválil od stredy otvorenie ďalších prevádzok*. Available at: <https://www.health.gov.sk/Clanok?covid-19-21-04-2020-obchody>
  - [16] Ministry of Health SR. (2020). *COVID-19: Od stredy sa majú otvárať ďalšie obchody a služby*. Available at: <https://www.health.gov.sk/Clanok?covid-19-04-05-2020-obchody>
  - [17] Profesia.sk. (2020). *Koronavírus ovplyvňuje trh práce. Profesia sa snaží pomôcť firmám, aby neprerušovali nábor, pomôcť má nová služba video pohovorov*. Available at: <https://firma.profesia.sk/korona-ovplyvnuje-trh-prace-profesia-sa-snazi-pomoc-firmam-aby-neprerusovali-nabor-y-pomoc-ma-nova-sluzba-video-pohovorov/>
  - [18] Profesia.sk. (2020). *Firmy požiadali vládu o súbeh práce z domu a OČR. Podľa zamestnávateľov prinesie plusy nielen pre rodičov a firmy, ale aj pre štát*. Available at: <https://firma.profesia.sk/firmy-poziadali-vladu-o-subeh-prace-z-domu-ocr-podla-zamestnavatelov-prinesie-plusy-nielen-pre-rodicov-firmy-ale-aj-pre-stat/>
  - [19] Profesia.sk. (2020). *Najviac home officu vidíme v IT, najmenej v cestovnom ruchu. Slovinci tvrdia, že doma pracujú rovnako, či dokonca sú produktívnejší ako na pracovisku*. Available at: <https://firma.profesia.sk/najviac-home-officu-vidime-v-najmenej-v-cestovnom-ruchu-slovinci-tvrdia-ze-doma-pracuju-rovnako-ci-dokona-su-produktivnejisi-ako-na-pracovisku/>
  - [20] Profesia.sk. (2020). *Možnosť pracovať aj z domu spomínajú zamestnávatelia čoraz častejšie aj v ponukách. Pandémia môže tento benefit výrazne rozšíriť*. Available at: <https://firma.profesia.sk/moznost-pracovat-aj-z-domu-spominaju-zamestnavatelia-c-oraz-castejsie-aj-v-ponukach-pandemia-moze-tento-benefit-vyrazne-rozirit/>
  - [21] Profesia.sk. (2020). *Práca z domu a vôľa neznižovať platy. Takto bojujú firmy na Slovensku s koronovírusom*. Available at: <https://firma.profesia.sk/aktualita/praca-z-domu-a-vola-neznizovat-platy-takto-boju-firmy-na-slovensku-s-korona-virusom/>
  - [22] Profesia.sk. (2020). *Home office produktivitu neznižuje*. Available at: <https://firma.profesia.sk/aktualita/ako-sa-firmy-pripravuju-na-navrat-zamestnancov>
  - [23] Profesia.sk. (2020). *Väčšina zamestnávateľov obnovila príchod na pracoviská v júni. Nie každému zamestnancovi to vyhovuje*. Available at: <https://firma.profesia.sk/vacsina-zamestnavatelov-obnovila-prichod-na-pracoviska-v-juni-nie-kazdemu-zamestnancovi-vyhovuje/>
  - [24] Profesia.sk. (2020). *Správne rozhodnutia, nové formy komunikácie a práca z domu – zistite, ako preživali firmy posledné mesiace*. Available at: <https://firma.profesia.sk/aktualita/spravne-rozhodnutia-a-nove-formy-komunikacie-a-praca-z-domu-zistite-ako-firmy-prezivali-posledne-mesiace/>
  - [25] Profesia.sk. (2020). *Koronakríza znížila platy v pracovných ponukách. Stalo sa tak prvýkrát od zavedenia povinnosti uvádzať mzdy do inzerátov*. Available at: <https://firma.profesia.sk/koronakrizaznizila-platy-v-pracovnych-ponukach-stalo-sa-tak-prvykrat-od-zavedenia-povinnosti-uvadat-mzdy-inzeratov/>
  - [26] Profesia.sk. (2020). *Prísnejšie opatrenia opäť spomalili trh práce. Výrazný prepad vidíme okrem gastru a cestovného ruchu tiež v zákaznickej podpore a administratíve*. Available at: <https://firma.profesia.sk/prisnejsie-opatrenia-opat-spomalili-trh-prace-vyrazny-prepad-vidime-okrem-gastru-cestovneho-ruchu-tiez-v-zakaznickej-podpore-administrative/>
  - [27] Profesia.sk. (2020). *Ako firmy zvládajú druhú vlnu: sú zamestnanci, ktorí pracujú z domu šťastnejší?* Available at: <https://firma.profesia.sk/aktualita/ako-firmy-zvladaju-druhu-vlnu-su-zamestnanci-ktori-pracuju-z-domu-stastnejisi/>

- firmy-zvladaju-druhu-vlnu-su-zamestnanci-ktori-pracuju-z-domu-stastnejši/
- [28] Profesia.sk. (2020). *Podľa personalistov bude veľká časť zamestnancov pracovať z domu aj v roku 2021. Mnohým by prospeli školenia v oblasti time manažmentu či riadenia stresu.* Available at: <https://firma.profesia.sk/podla-personalistov-bude-velka-cast-zamestnancov-pracovat-z-domu-aj-v-roku-2021-mnohym-prospeli-skolenia-v-oblasti-time-manazmentu-ci-riadenia-stresu/>
- [29] Profesia.sk. (2021). *Koronakríza je s nami už celý rok: Firmy dnes aj napriek opatreniam uverejňujú tisíce pracovných ponúk.* Available at: <https://firma.profesia.sk/firmy-aj-napriek-opatreniam-uverejnuju-tisice-pracovnych-ponuk-stale-vsak-plati-ze-od-pandemie-bolo-u-nas-najlepsie-v-septembri/>
- [30] Profesia.sk (2021). *Rastie počet pracovných ponúk, ktoré vôbec nepožadujú príchod na pracovisko.* Available at: <https://firma.profesia.sk/rastie-pocet-pracovnych-ponuk-ktore-vobec-nepozaduju-prichod-na-pracovisko/>
- [31] Profesia.sk (2021). *Stále viac firiem hľadá zamestnancov, ktorí sa už vôbec nemusia ukázať na pracovisku.* Available at: <https://firma.profesia.sk/stale-viac-firiem-hlada-zamestnancov-ktori-sa-uz-vobec-nemusia-ukazat-na-pracovisku/>
- [32] Profesia.sk (2021). *V práci nie sme samotári: Po roku a pol s pandémiou chce pracovať z domu iba 8 percent Slovákov.* Available at: <https://firma.profesia.sk/v-praci-nie-sme-samotari-po-roku-pol-s-pandemiou-chce-pracovat-z-domu-iba-8-percent-slovakov/>
- [33] Profesia.sk (2021). *S čím majú Slováci najväčší problém pri home office a čo im pomáha? Dáta pre firmy, ako zlepšiť nielen pracovný život svojim zamestnancom.* Available at: <https://firma.profesia.sk/s-cim-maju-slovaci-najvacsi-problem-pri-home-office-co-im-pomaha-data-pre-firmy-ako-zlepsit-nielen-pracovny-zivot-svojim-zamestnancom/>
- [34] Profesia.sk (2021). *November priniesol lockdown zo dňa na deň: Ako sa to prejavilo na pracovných ponukách?* Available at: <https://firma.profesia.sk/november-priniesol-lockdown-zo-dna-na-den-ako-sa-prejavilo-na-pracovnych-ponukach/>
- [35] Profesia.sk (2021). *Preferujú zamestnávateľia vykonávanie práce v kancelárii alebo nastala zmena? Ako sa aktuálne vyvíja počet ponúk s čiastočným alebo úplným home office?* Available at: <https://firma.profesia.sk/ako-sa-aktualne-vyvíja-pocet-ponuk-s-cias-tocnym-alebo-uplnym-home-office/>
- [36] Profesia.sk (2022). *Ako ovplyvnila situácia na Ukrajine zamestnávateľov na Slovensku?* Available at: <https://firma.profesia.sk/ako-ovplyvnila-situacia-na-ukrajine-zamestnavatelov-na-slovensku/>
- [37] Profesia.sk (2022). *Vývoj platov v roku 2022: Priemerná mzda v pracovných ponukách na Profesii prekročila 1300 eur v hrubom.* Available at: <https://firma.profesia.sk/vyvoj-platov-v-roku-2022-priemerna-mzda-v-pracovnych-ponukach-na-profesii-prekrocila-1300-eur-v-hrubom/>
- [38] Profesia.sk (2022). *Firmy vracajú ľuďom späť, čo predtým škrtali. Ako vyzerá aktuálna ponuka zamestnaneckých benefitov?* Available at: <https://firma.profesia.sk/firmy-vcavaju-ludom-spat-co-predtym-skrтали-ako-vyzera-aktualna-ponuka-zamestnaneckych-benefitov/>

# History of Statistical Thinking: From Uncertainty to Uncertain Knowledge

Jan Kalina<sup>1</sup>, Lubomír Soukup<sup>2</sup>

<sup>1</sup>The Czech Academy of Sciences, Institute of Computer Science, Prague, Czech Republic

<sup>2</sup>The Czech Academy of Sciences, Institute of Information Theory and Automation, Prague, Czech Republic

<sup>1</sup>kalina@cs.cas.cz, <sup>2</sup>soukup@cs.cas.cz

**Abstract**—Currently, an enormous amount of data is available to the humankind in various fields and it is exactly the data (information) which may be transferred to practically useful knowledge. The data are subject to uncertainty and their analysis, i.e. extracting knowledge from the data, requires statistical thinking and statistical methods. Thus, the concept of the knowledge society requiring reliable knowledge to be available to all citizens is heavily depending on statistics. This paper is devoted to an overview of the historical development of basic probabilistic and statistical concepts. Such overview is intended to encourage readers to think anew about statistical ideas in the light of their historical development. The paper recalls that any knowledge obtained by statistical methods is highly probable but not absolutely certain.

**Keywords** – history of statistics, information and knowledge, uncertainty, probability, data analysis, methodology of science

## I. INTRODUCTION

A transformation of the current society towards to the ideals of a knowledge society has been a subject of intensive debates as well as research. Such discussions require to understand the concepts of information and knowledge, and to consider methods for acquiring knowledge from given information, i.e. for analyzing data, which are most commonly obtained by means of direct measurements, within randomized experiments, or in surveys [1,2].

The data are typically imprecise because of errors coming from various sources, which can

classified as instrumental errors, method errors, personal errors, errors caused by an unsuitable design, or random errors [3]. Therefore, the knowledge acquired from the data is always valid with some level of uncertainty. The data acquired in various fields of human activities require to be analyzed by means of tools of multivariate statistics, machine learning, information theory, or artificial intelligence. Specific modern tools have to be exploited when dealing with Big Data.

The everyday (statistical) analysis of data from various sources gradually contributes to the shift of the whole society towards the ideals of the knowledge society. Available books on history of statistics are typically focused only on specific periods of history [4], or are very intensively devoted to historical aspects without bringing specific conclusion for the current situation [5]. On the other hand, this paper is interested in a very broad overview of the history of statistical thinking. While the history of commonly used statistical methods has been thoroughly overviewed in specialized monographs [6], our aim is not to write biographies of important personalities but rather to present a broader context of historical development of (philosophical) thinking related to randomness, uncertainty, and data analysis.

## II. ORIGINS OF PROBABILITY THEORY

Neither Ancient Greece nor medieval Europe were able to capture randomness and uncertainty and to acknowledge their importance. Therefore, they have not incorporated probability thinking to their philosophical systems. This is true in

spite of the fact that randomness is also explicitly mentioned in the biblical text, e.g. Ecclesiastes 9:11 claims that success in the world (in secular issues) is often governed by randomness (chance), or the limitations of our knowledge are confessed in 1 Corinthians 13:9. Still, it is true that modern probabilistic thinking stems from philosophical and theological considerations; Pascal, Bernoulli and Leibniz namely were not only interested in mathematical aspects, but they all devoted themselves also to theology.

Pierre de Fermat (1607-1665) and Blaise Pascal (1623-1662) are acknowledged as founders of probability calculus. Fermat and Pascal attempted to answer the question raised by the French gambler Chevalier de Méré related to the so-called problem of division of stakes. The problem was how to fairly divide the stake when a hazard game is unfinished. As the very beginning of probabilistic thinking, their correspondence from the year 1654 is usually considered. Even today, their correspondence is interpreted as a useful teaching resource [7]. Pascal's probability computations can be interpreted as more influential than his construction of a calculator *la Pascaline*, which is perceived as a predecessor of a modern computer.

Fermat and Pascal had an influence on Christian Huygens (1629-1695), who wrote the historically first work devoted to probability calculus. This treatise *De ratiociniis in ludo aleae* (in English *On the Value of Chances in Games of Fortune*) was published already in 1657 as a supplement of a book [8] published by the professor of Huygens.

Jacob Bernoulli (1655-1705) is considered to be the founder of probability theory as a self-standing scientific discipline especially thank to his masterly book *Ars Conjectandi* [9], which was published after the death of the author by his nephew Nicolaus Bernoulli (1687-1759). The English title (*The Art of Conjecturing*) evokes that Bernoulli perceives probability calculus as the task to compute (or in fact assign) a certain probability to different random phenomena. The book [9] is inspired by Huygens and is largely devoted to combinatorics or 0-1 trials, i.e. Bernoulli trials or trials with only two possible outcomes. The book was very influential after being published and had also a direct influence on Abraham de Moivre [10], who will be discussed later.

Gottfried Wilhelm Leibniz (1646-1716) is well known as a German mathematician, philosopher and theologian. It is much less known that Leibniz was interested in probability for his whole life. Already in his dissertation thesis, Leibniz was the first in history who defined conditional probability. In his logical works, he presented the very first explicit definition of classical probability [11]. He literally understood probability as a degree of possibility. Further he developed philosophical ideas about probability in communication with Jacob Bernoulli [12]. However, Leibniz has never contributed to developing mathematical aspects of probability calculus.

### III. ABRAHAM DE MOIVRE

Abraham de Moivre (1667-1754) investigated mathematical foundations of hazard games and overviewed his knowledge in a very first textbook on probability theory.

Moivre's book *Doctrine of Chances* [13], where the word "chance" correspond to the current concept of randomness, was published in 1718 as an English extension of Moivre's treatise *De Mensura Sortis* from 1711; the English title is known as *On the Measurement of Chance*. Later, Moivre revised the book and prepared its second edition in 1738 and then to the third (again largely revised) in 1759. Compared to the first edition, each of the next editions was enriched by an improved introduction and a series of new problems and their solutions.

The *Doctrine of Chances* [13] was written for a broad lay readership of non-mathematicians. It was in fact a practical handbook or manual for gamblers, which was written in English and thus become a bestseller. Moivre explained all concepts and approaches on comprehensible practical examples and proceeds from simple situations to more complex ones. Already in the introduction, Moivre presented elementary examples allowing the readers to grasp the concept of chance and other concepts as well as his way of thinking. Then the book quickly proceeds to more practical problems. This whole book is formed by an attempt to present a systematic review of all possible tasks from gambling practice, and this explains why Moivre was denoted as the new Euclid after the father of the axiomatic system in geometry (325-260 B.C.).

Moivre was also interested in applying probability calculus in the analysis of mortality

data (mortality tables or death rates). Moivre was able to perceive statistical estimation as an inverse probabilistic problem, which is based on estimating probabilities of a given random event based on data observed in reality. In the year 1733, he derived the formula for the density of normal distribution as a special case of the binomial distribution. Moivre's further important works include the book *Annuities upon Lives* (1725) about computing insurance premiums for life insurance, and *Miscellanea Analytica* (in English *Miscellaneous Problems in Mathematical Analysis*) published in 1730, where he is proved as an excellent expert on mathematical analysis [14]. Moivre particularly contributed to infinitesimal calculus, theory of infinite series, geometry, and algebra.

#### IV. ORIGINS OF STATISTICAL METHODS

The first statistical tasks did not consider any uncertainty or probability. These tasks included censuses performed already in the ancient times, e.g. in the Babylonian Empire around the year 3800 B.C. Statistical thinking based on probability calculus (i.e. from the 17<sup>th</sup> century) started to develop in three distinct areas: hazard games, insurance, and physics. These three fields soon started to influence each other. Mortality tables served as a valuable source of data for fixing the payments of life insurance. A larger number of thinkers was devoted to the analysis of mortality data including also the astronomer Edmund Halley (1656-1742). We can say that statistical estimation discussed below was proposed for the context of analyzing measurements [4] and only much less for designed experiments, which evolved in a scientific way only later.

The Bayes theorem for evaluating conditional probabilities first appeared in a posthumously published paper by Thomas Bayes (1702-1761). It seems not to be much known that estimation based on the Bayes theorem is historically older than the frequentist (non-Bayesian) approach to estimation. From the beginnings, the philosophy of the Bayesian statistical analysis of physical measurements was to naturally combine the results of given measurements with available prior measurements [15]. This is true for Bayesian estimates of location and also for estimates of variability, which allow to evaluate the uncertainty of the point estimates.

#### V. PIERRE-SIMON DE LAPLACE

Pierre-Simon de Laplace (1749-1827) was a universal thinker, who developed statistical ideas of Bayes and Moivre. Laplace also overviewed the whole celestial mechanics. Thus, astronomy served him as a valuable inspiration source for evaluating data contaminated by errors, just like it inspired a number of other experts of his era who investigated measurement errors.

Laplace perceived Bayesian probabilistic thinking as a natural extension of mathematical logic and common sense and greatly contributed to the development of probability theory e.g. by rediscovering the Bayes theorem [16]. Laplace explained his ideas in his fundamental work *A Philosophical Essay on Probabilities*. The prior distribution corresponds in Laplace's work to the uncertainty.

Laplace was intensively interested in analyzing astronomic measurements by regression models and was aware of the harmful effect of measurement errors. Apart from the median, Laplace also propagated using the regression median in the linear regression model. Laplace obtained an explicit solution for the regression median, which was previously outlined by Roger Joseph Boscovich (1711-1787). The Laplace's work on the distribution of the median published in 1818 was in fact the very first rigorous work on robust statistical estimation.

#### VI. CARL FRIEDRICH GAUSS

Carl Friedrich Gauss (1777-1855) belonged to the pioneers of a consistent usage of probability theory in the processing of measurements from various fields, mainly in astronomy, geodesy, and physics. By investigating properties of measurement errors and formulating the law of error propagation, he laid foundations of the theory of errors.

Gauss had strong mathematical skills and at the same time a rich practical experience with measurements and his statistical work aimed at estimating physical constants by removing (filtering out) measurement errors from the relevant information. He developed the maximum likelihood estimation, which became one of pillars of mathematical statistics. Using the maximum likelihood method, Gauss derived the normal distribution denoted as "the law of errors" and considered it as a suitable model for measurement errors. By means of a Bayesian

argument, Gauss also theoretically justified the least squares estimator [17].

## VII. ADOLPHE QUETELET

Adolphe Quetelet (1796-1874) was a Belgian polymath, who worked as a professor of astronomy and mathematics at the Royal Military Academy in Brussels. He was an expert both in physics and mathematics and was well known of fascinating discoveries in physics of the 19th century. He strived for exploiting probability calculus in the analysis of large-scale data in physics and also in other fields than physics, such as in sociology, demography, criminalistics etc. Thus he found a new field, which was at that time denoted as social physics or social mechanics. Quetelet became the main exponent of the new field and thus became a predecessor of current sociology. He was using physical methods to the science of man. These physical methods naturally include probability and statistics, which both were heavily associated with the analysis of physical measurements [18].

Quetelet was involved in the economic statistics. Here, the aim was focused on collecting facts, which described the human activities in the country or the state of the society and its development. Such collecting data included also comparing corresponding facts acquired in different countries [19].

As the president of the Belgian Statistical Office and at the same time a gifted organizer, Quetelet actively contributed to the development of the official state statistics. Particularly, he introduced regular censuses every ten years starting from 1846, and he introduced modern questionnaires for the purpose. At the same time he was the main initiator and organizer of international cooperation of statisticians. The official state statistics was subsequently organized also in other countries following Quetelet's model implemented in Brussels [20].

Quetelet was the first who applied the normal distribution to measurements related to humans, and in a more general sense he was the first who applied the normal distribution to different phenomena than measurement errors. He interpreted the normal distribution, which was at the time denoted as the law of errors of (Gaussian) curve of errors, as a universal principle. He used theological arguments for using the normal distribution for analyzing groups of individuals [21]. Such considerations

always assumed a homogeneous population and Quetelet compared an individual with the average. Instead of measurement errors considered by Gauss, the uncertainty in Quetelet's data comes from individual variability. Quetelet's anthropometric measurements were performed on random samples from the entire population. The averaged values of the measured dimensions thus expressed the averaged characteristics of the appearance of a typical representative of the given population.

Quetelet enjoyed evaluating various indicators of social phenomena aggregated over the whole Belgium. He especially focused on data about crime or the number of suicide deaths. He also constructed tables of the counts of mental diseases for various countries [21].

This led Quetelet to introduce the concept of an average human. According to his main work [22], such being remains only fictitious but with ideal properties in all aspects. Quetelet's interpretation is different from that of Gauss, who considered the value of a measured physical variable to be a constant. Gauss measured objectively existing variables and the measurement would find the constant precisely in the ideal situation without measurement errors. Moreover, the variability of physical measurements is much smaller compared to anthropometric measurements. Quetelet was aware that for this reason he needs to perform a much larger number of measurements.

## VIII. FRANCIS GALTON

Francis Galton (1822-1911), who is generally acknowledged as one of the most brilliant and universal scientists, was professor of eugenics in London. A very extensive biography of Galton was written by his main follower and admirer Karl Pearson (1857-1936) [23]. Galton was thanks to his medical education very well prepared to study different scientific disciplines. He was literally obsessed by performing measurements and quantification and he devoted much time to performing measurements or evaluations (counting) of various phenomena.

Galton was able to extensively influence statistics with his original ideas, even though he has never formulated them rigorously [24]. In fact, he did not even have a sufficient mathematical education; he started to study mathematics in Cambridge in 1840, but in the third grade left the study. Only after 1869, Galton started to become acquainted with statistics [25],

as he started to feel the necessity to apply statistics in his research of man. Galton published papers with original statistical approaches immediately from the beginning of 1870s, but presented the main ideas in a very short period between 1885 and 1888 [25].

Galton introduced correlation analysis and his study of correlations instead of causality dramatically changed the European statistical tradition. His first application of correlation analysis was in the anthropological task of comparing the height of children with the length of their bones [26], but he needed the method primarily for the study of heredity [27]. When Galton stopped his active interest in science in 1888, he left open problems in correlation analysis to a younger generation and the current correlation coefficient was proposed by Pearson by only a slight modification of Galton's original definition [28]. Further, Galton was the first to use the concept of regression, while his understanding of regression is now denoted as regression to the mean [24].

For Gaussian distribution, Galton introduced the notion of normal curve of distributions, or more shortly normal curve, where the world normal is clearly related to a norm as a standard, model, or pattern. He was the first to discover two-dimensional Gaussian distribution; nevertheless, he had to ask for help his friend Hamilton Dickson for a correct mathematical description [25]. Galton used the (Gaussian) method of least squares for estimating regression parameters [29].

In addition, Galton introduced the concepts of percentiles (originally as centiles) and quantiles, and also their special cases (quartiles, deciles). In the work [30], Galton applied them to various anthropometric dimensions measured in his laboratory. By defining quantiles, Galton was able to overcome the mere averaging of variables of Quetelet (p. 293 of [31]), who was subjectively searching for suitable limits for normally distributed variables. Galton replaced the concept of error by deviation from normality. In the eugenic spirit, he perceived individuals different from the norm to be pathologically non-normal, i.e. deviant.

Galton at the end of his life acted as a patron of biometry (biometrics). The aim of biometry was to perform measurements of outward physiological features on living organisms (including humans). Galton's contribution to statistics was distinct also because his ideas were

elaborated and popularized by the very influential Karl Pearson, who also founded and led the English biometric school.

In 2022, the 200th anniversary of Galton's birthday is recalled. Still, Galton's work has been very critically evaluated [32], because his scientific attempts stemmed from eugenics. He struggled for political power for "intellectually superior" individuals and also understood eugenics as an alternative to all religions.

## IX. KARL PEARSON

Karl Pearson (1857-1936) studied a diverse spectrum of scientific disciplines and was able to achieve a series of excellent attainments and valuable scientific results. In 1911, he founded the first statistical department in the world; it was the Department of Applied Statistics in London, where he acted as professor. The department was in fact interdisciplinary and included also biometric and eugenic laboratories.

Pearson felt an urgent need to use statistics in applied research tasks in anthropology, evolution biology, medicine, epidemiology, and mainly eugenics. The boundary between statistics and biological disciplines was very unclear at the beginning of the 20th century. As an example, let us mention Pearson's concept of contingency table [33], which is until nowadays a general statistical term for a table of counts. Pearson analyzed such tables when searching for evidence of the evolution theory, which was according to him a purely statistical problem. Contingency was understood as a much discussed phenomenon in evolution theory describing randomness, uncertainty, unpredictable fact jointly influencing the whole species of organisms [34]. Therefore, also Charles Darwin (1809-1882) in his evolution theory made the difference between laws, which remain in the background, and contingency, which is revealed in details. The term contingency table remained in statistics as one of many statistical concepts, which obtained a biological name.

As the founder of the journal *Biometrika*, Pearson led unjustified attacks on the legacy of Gregor Mendel (1822-1884), the founder of genetics; Pearson namely incorrectly believed in a continuous character of heredity. Pearson struggled for improving biological and genetic features of individuals, therefore predicting the genetic predispositions (and in general predicting under uncertainty) was interesting for him.



Keeping in mind the biological motivation, Pearson laid the foundations of estimation theory, hypothesis testing, and multivariate statistics. He is the author of the concept of standard deviation. He founded the whole multivariate statistics for the needs of anthropology [35]. In his famous chi-square test, Pearson made a substantial mistake, which was later corrected by Ronald A. Fisher, who is discussed in a later section. This only escalated the already quite tense relationship between both scientists. For this reason, both Pearson and Fisher laid foundations of modern statistics in a parallel way, because each of them avoided the methods derived by his rival [36].

#### X. RONALD A. FISHER

Ronald A. Fisher (1890-1962) is denoted as the father of modern statistics [37]. Fisher has an extraordinary credit in establishing the foundations of modern statistics and in developing statistical methods for biological applications. Fisher devoted his research also to eugenics and evolutionary biology. In the study of genetics, he was interested in predicting the hereditary features (under uncertainty) and was able to understand the discrete character of heredity.

In statistics, Fisher developed the field of statistical point estimation by deriving properties of maximum likelihood estimators. He contributed to the theory of hypothesis testing by introducing permutations tests and analysis of variance. In multivariate statistics, his main contribution was the proposal of linear discriminant analysis. Further, Fisher developed statistical principles of design of randomized experiments. He also predeceased ideas of information theory by understanding measurements to reduce uncertainty of a system; in this spirit, he proposed the Fisher information of an unknown parameter as a quantification of the information carried in a measurement about this parameter.

Fisher criticized Pearson's statistical methods and refused to use them. This can be illustrated on Fisher's opinion that smoking does not cause cancer. Pearson previously published results of a study, where the idea of smoking causing cancer was supported by the correlation coefficient evaluated in a medical study. Fisher was ironically attacking the study and in an analogous way demonstrated that the number of apples imported to England is associated (in a causal sense) with the number of divorces [38].

Naturally this interpretation was intentionally wrong, because correlation (statistical association) does not necessarily mean that there is a causal relationship between the two variables.

#### XI. STATISTICAL THINKING: FROM THE HISTORY TOWARDS THE KNOWLEDGE SOCIETY

Statistical thinking represents a crucial approach for transforming available data to useful knowledge and thus remains important also in the current era of big or high-dimensional data [39]. Statistical methodology is irreplaceable in complex data analysis tasks in natural sciences [40], clinical medicine including molecular genetics [41] or brain research [42], engineering, metrology [43], economics [44], or management [45]. In all these fields, tendencies towards using information-based principles (based on learning knowledge from given data) have been well known and Big Data and artificial intelligence tools become more available thanks to the digitalization accelerated by the COVID-19 pandemic. Decision making tasks represent an important class of problems, where statistical thinking plays a crucial role [46].

The remarkable personalities mentioned in this paper, who have influenced the development of statistical thinking, much contributed to our current scientific way of perceiving the objective reality. Decision making based on estimating conditional probabilities, developed by the ideas of Leibniz, Bayes and Laplace, should be a natural component of our decision making. Hypothesis testing derived by Pearson, regression modeling developed by Galton, or decision making of Fisher are examples of established tools, which are reliable under the assumption of normal distribution introduced by Moivre and popularized by Gauss. Also the renowned computer scientist Lofti Zadeh (1921–2017), founder of fuzzy mathematics, contributed to formalizing the idea that the objective world can be hardly captured by objective criteria. At any case, the results of statistical analysis are influenced by the uncertainty in the data and require their diagnostic tools [47,48]. They are valid for an average situation (ignoring the influence of random errors), as pointed out by Quetelet.

This paper is intended to encourage readers to think anew about statistical ideas and methods and the motivation for their using in the light of the historical context. A mere acknowledging that everyday processes around us have a random

character seems to represent an unusual situation or obstacle for a general lay public, because humans seem not to be prepared by their biological evolution to incorporate uncertainty to their own thinking [49]. Therefore, statistics constantly needs an intensive popularization for a broad public to arouse a well-deserved social interest.

## XII. CONCLUSION

Whenever statistical methods are used to acquire knowledge, it is necessary to give a warning that such knowledge is influenced by uncertainty, and this is why results of statistical analysis have to be always interpreted with care. This remains to be true also in the context of the knowledge society, where the knowledge can be hardly obtained from given data without statistical methods. Thus, statistics contributes hand in hand with other disciplines towards the development of the knowledge society. The Czech polymath Jan Amos Comenius (1592-1670), who can be perceived as a predecessor of the knowledge society, demanded the science to be available and beneficial for the whole humankind, and prophesied a vision of a universal science as a light for the world leading to a general wisdom.

## REFERENCES

- [1] Philips, F., Yu, C.Y., Hameed, T., & El Akhdary, M.A. (2017). The knowledge society's origins and current trajectory. *International Journal of Innovation Studies*, 1, 175-191.
- [2] Robinson, A. (2007). *The story of measurement*. Thomas & Hudson.
- [3] Crowder, S., Delker, C., Forrest, E., & Martin, N. (2020). *Introduction to statistics in metrology*. Springer.
- [4] Stigler, S.M. (2000). *The history of statistics: The measurement of uncertainty before 1900*. Belknap Press.
- [5] Gorroochurn, P. (2016). *Classic topics on the history of modern mathematical statistics: From Laplace to more recent times*. Wiley.
- [6] Hald, A. (2006). *A history of parametric statistical inference from Bernoulli to Fisher, 1713 to 1935*. Springer.
- [7] Devlin, K. (2010). The Pascal-Fermat correspondence: How mathematics is really done. *Mathematics Teacher*, 103, 579-582.
- [8] Van Schooten, F. (1657). *Exercitationum mathematicarum*. Volume 5. Elsevier.
- [9] Bernoulli, J. (1713). *Ars conjectandi*. Thurnisiorum Fratrum.
- [10] Schneider, I. (2006). Direct and indirect influences of Jakob Bernoulli's *Ars Conjectandi* in 18th century Great Britain. *Electronic Journal for History of Probability and Statistics*, 2, 1.
- [11] Gorroochurn, P. (2011). Errors of probability in historical context. *American Statistician*, 65, 246-254.
- [12] Schneider, I. (1984). The role of Leibniz and Jakob Bernoulli for the development of probability theory. *Llull*, 7, 69-89.
- [13] de Moivre, A. (1718). *The doctrine of chances: or, A method for calculating the probabilities of events in play*. W. Pearson.
- [14] de Moivre, A. (1730). *Miscellanea analytica de seriebus et quadraturis*. J. Tonson & J. Watts.
- [15] Ghosh, S.K. (2019). *Bayesian statistical methods*. Chapman & Hall/CRC.
- [16] Jaynes, E.T. (2003). *Probability theory: The logic of science*. Cambridge University Press.
- [17] Sheinin, O.B. (1996). *The history of the theory of errors*. Hänsel-Hohenhausen.
- [18] Caponi, S. (2013). Quetelet, the average man and medical knowledge. *História, Ciências, Saúde-Manguinhos*, 20, 830-847.
- [19] Aldrich, J. (2010). Mathematics in the London/Royal Statistical Society 1834-1934. *Electronic Journal for History of Probability and Statistics*, 6, 1-33.
- [20] Hankins, F.H. (1908). *Adolphe Quetelet as statistician*. Columbia University.
- [21] Jahoda, G. (2015). Quetelet and the emergence of the behavioral sciences. *Springerplus*, 4, 1.
- [22] Quetelet, A. (1835). *Sur l'homme et le développement de ses facultés, ou Essai de physique sociale*. Bachelier.
- [23] Pearson, K. (1914, 1924, 1930). *The life, letters and labours of Francis Galton I, II, III*. Cambridge University Press.
- [24] Senn, S. (2011). Francis Galton and regression to the mean. *Significance*, 8, 124-126.
- [25] Cowan, R.S. (1972). Francis Galton's statistical ideas: The influence of eugenics. *Isis*, 63, 509-528.
- [26] Galton, F. (1888). Co-relations and their measurement, chiefly from anthropometric data. *Proceedings of the Royal Society of London*, 45, 135-145.
- [27] Stigler, S.M. (1989). Francis Galton's account of the invention of correlation. *Statistical Science*, 4, 73-79.
- [28] Rodgers, J.L., & Nicewander, W.A. (1988). Thirteen ways to look at the correlation coefficient. *American Statistician*, 42, 59-66.
- [29] Gorroochurn, P. (2016). On Galton's change from 'reversion' to regression. *American Statistician*, 70, 27-231.
- [30] Galton, F. (1885). Anthropometric per-centiles. *Nature*, 31, 223-225.
- [31] Koenker, R. (2005). *Quantile regression*. Cambridge University Press.
- [32] MacKenzie, D. (1976). Eugenics in Britain. *Social Studies of Science*, 6, 499-532.
- [33] Pearson, K. (1904). Mathematical contributions to the theory of evolution XIII: On the theory of contingency and its relation to association and normal correlation. *Biometric Series*, 1.
- [34] Gould, S.J. (1989). *Wonderful life: The Burgess shale and the nature of history*. Norton.
- [35] Van Vark, G.N., & Howells, W.W. (1984). *Multivariate statistical methods in physical*

- anthropology: A review of recent advances and current developments.* Reidel Publishing Company.
- [36] Agresti, A. (2002). *Categorical data analysis*. 2<sup>nd</sup> edn. Wiley.
- [37] Krishnan, T. (1997). Fisher's contribution to statistics. *Resonance*, 2, 32-36.
- [38] Yates, F., & Mather, K. (1963). Ronald Aylmer Fisher. *Biographical Memoirs of Fellows of the Royal Society of London*, 9, 91-120.
- [39] Kalina, J., & Duintjer Tebbens, J. (2015). Algorithms for regularized linear discriminant analysis. In *Proceedings of the 6<sup>th</sup> International Conference on Bioinformatic Models, Methods and Algorithms Bioinformatics '15* (pp. 128-133).
- [40] Stewart, I. (2002). *Does God play dice? The new mathematics of chaos*. 2<sup>nd</sup> edn. Blackwell Publishing.
- [41] Kalina, J. (2018). A robust pre-processing of BeadChip microarray images. *Biocybernetics and Biomedical Engineering*, 38, 556-563.
- [42] Kalina, J., & Hlinka, J. (2017). Implicitly weighted robust classification applied to brain activity research. *Communications in Computer and Information Science*, 690, 87-107.
- [43] Kalina, J., & Tichavský, J. (2020). On robust estimation of error variance in (highly) robust regression. *Measurement Science Review*, 20, 6-14.
- [44] Köhn, J. (2017). *Uncertainty in economics: A new approach*. Springer.
- [45] Kalina, J., & Renšová, D. (2015). How to reduce dimensionality of data: Robustness point of view. *Serbian Journal of Management*, 10, 131-140.
- [46] Kalina, J., Seidl, L., Zvára, K., Grünfeldová, H., Slovák, D., & Zvárová, J. (2013). System for selecting relevant information for decision support. *Studies in Health Technology and Informatics*, 186, 83-87.
- [47] Saleh, A.K.M.E., Píček, J., & Kalina, J. (2012). Re-estimation of the parameters of a multiple regression model with measurement errors. *Metrika*, 75, 311-328.
- [48] Kalina, J. (2015). Three contributions to robust regression diagnostics. *Journal of Applied Mathematics, Statistics and Informatics*, 11, 69-78.
- [49] Kahneman, D. (2011). *Thinking, fast and slow*. Farrar, Straus and Giroux.

# Impact Factor of the Rest Rewarding Taxes

Constantinos Challoumis<sup>1</sup>

<sup>1</sup>National and Kapodistrian University of Athens (N.K.U.A.), Athens, Greece

<sup>1</sup>challoumis\_constantinos@yahoo.com

**Abstract**—This paper is about the comparison of the cycle of money with the impact factor of rewarding taxes, and without it. This analysis is based on the cycle of money and the impact factor of rest rewarding taxes. This means that we have a study about the structural characteristics of the economy which support the market and the robustness of this economy. Thence, the impact factor of the rest rewarding taxes is important as enforces the economic dynamic of any economy. As rest rewarding taxes are considered the taxes which return to the economy making it have more quality characteristics. Three types of taxes boost the economy, which is about education, health, and these are about the structure and functionality of the economy e.g. electronic services by the authorities which decline the bureaucracy, etc. Then, we extract conclusions about the importance of this impact factor. The current analysis is used the Q.E. method.

**Keywords** - rest rewarding taxes, cycle of money

## I. INTRODUCTION

This paper analyzes the case of the cycle of money with and without all the impact factors of rewarding taxes. Then, in this scrutiny in one case is used the impact factor of the rest rewarding taxes is and in the other case is avoided. Then, using the Q.E. method extracted conclusions, about the importance of this impact factor in the economy. Moreover, this impact factor is about the administration of the public sector to the private sector and the returns of taxes to the market. Additionally should be mentioned that any other rewarding taxes are excluded from this study to estimate the utility of this factor.

## II. MAIN INNOVATIONS OF BASEL 3.1

The contracts and the agreements between the participants of control transactions are these which determine the allocation of profits and losses. The agreements should mention the changes in the contracts. This is the reason why the tax authorities should make periodic inspections. The periodic specification of contracts is important for the comparability analysis. These periodic inspections of the companies which participate in controlled transactions are crucial for the arm's length principle. Then, the determination of the cost-sharing depends on the periodic check of companies that are tested parties. The scope of the companies of controlled transactions is to face the issues that relate to the taxation of their activities. Therefrom, the requirements for the companies of controlled transactions with the tax authorities should be in the range of the arm's length principle. Thereupon, the appropriate agreement of the companies of controlled transactions is that which permits them the maximization of their profits in tax environments with a low tax rate, and the maximization of costs in economic environments with a high tax rate [1-11].

Moreover, should be notified that the companies of controlled transactions and the same time the inspections of tax authorities are done under the condition of proportional adjustments [4]. The interpretation of the condition of the proportional adjustments is that the companies which participate in controlled transactions many times don't have the appropriate data and uncontrolled transactions of similar circumstances to compare and therefore they proportionally adjust their data [3,20-35]. This means that if the companies which are tested

parties conclude that the profits and losses of companies from uncontrolled transactions are much higher or much fewer than they make a proportional analogy to compare them with their data.

The production of goods or services creates profits and costs for the companies. Based on the prior scrutiny we have that:

$$u = s \cdot (z \cdot f + z \cdot d), \quad (1)$$

$$z = |\tilde{z} - 1|. \quad (2)$$

The symbol  $u$  is about the impact factor of the comparability analysis which has any method to the  $s$ . The symbol  $z$  is a coefficient that takes values between 0 and 1. What value could receive is determined by the influence of the method (using the best method rule) on the  $s$ . The symbol of  $f$  is about the cost which comes up from the production of goods, and the symbol of  $d$  is about the cost which comes from the distribution of the goods.

According to (1) and (2) is plausible to determine the following:

$$u_c = z \cdot f + z \cdot d, \quad (3)$$

$$b = (p - u_c) \cdot j_1. \quad (4)$$

The symbol of  $b$  is about the amount of taxes that should pay the companies of controlled transactions in the application of the arm's length principle. The  $u_c$  is the amount of money for tax obligations that can avoid through the allocations

of profits and losses. Moreover,  $j_1$  is a coefficient for the rate of taxes [36-43]. Then, author in [8] shows the case of the arm's length principle. In addition the case of the fixed length principle:

$$v = p \cdot j_2. \quad (5)$$

The symbol of  $v$  shows the taxes that should pay the enterprises of controlled transactions in the application of the fixed-length principle. Then,  $j_2$  is a coefficient for the rate of taxes in the case of the fixed length principle. Thereupon, we conclude according to the prior theory that:

$$v \geq b. \quad (6)$$

The tax for the companies which participate in controlled transactions of transfer pricing in the case of the fixed length principle is higher or at least equal to that of the case of the arm's length principle.

Thereupon, with the fixed length principle the enterprises of controlled transactions can tackle issues that come from the allocation of profits and losses. Thence, the tax authorities can face the transfer pricing effects on the global tax revenue.

The fixed length principle permits the recovery of the tax losses of the global tax revenue from the controlled transactions of the transfer pricing. The next scheme has illustrated the procedure that companies of controlled transactions follow for their allocations of profits and losses, the proportional adjustments of data, and the fixed length principle [4,12-19]. Thence, we have that:

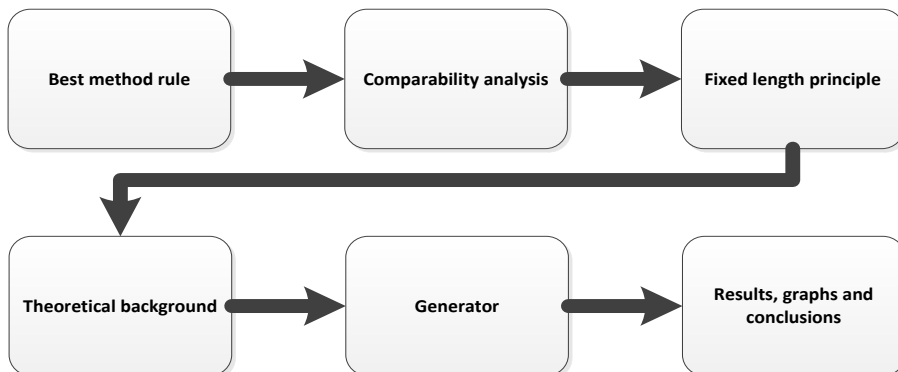

Figure 1. Cost sharing and application of fixed length principle.

It is determined the procedure of the fixed length principle and its quantity analysis for the determination of the behavior of the model. The next section has presented the theory of the cycle of money. Moreover, the methodology which followed stands on the Q.E. method.

### III. THE CYCLE OF MONEY AND THE IDEAL CASE OF THE CYCLE OF MONEY

For the scope of this analysis below are demonstrated:

$$\alpha = \alpha_s + \alpha_t \text{ or } (1/v) + \alpha_t, \quad (7)$$

$$x_m = m - a, \quad (8)$$

$$m = \mu + \alpha_p, \quad (9)$$

$$\mu = \sum_{i=0}^n \mu_i, \quad (10)$$

$$\alpha_p = \sum_{j=0}^m \alpha_{p_j}, \quad (11)$$

$$c_m = dx_m/dm, \quad (12)$$

$$c_\alpha = dx_\alpha/d\alpha, \quad (13)$$

$$c_y = c_m - c_\alpha. \quad (14)$$

The variable of  $\alpha$  has symbolized the case of the escaped savings. This means that we have savings that are not returning to the economy or come back after a long-term period. The variable of  $\alpha_s$  symbolizes the case that we have escaped savings that come from transfer pricing activities. The variable of  $\alpha_t$  it symbolizes the case that we have escaped savings not from transfer pricing activities but from any other commercial activity. For instance,  $\alpha_t$  could refer to the commercial activities which come from uncontrolled transactions [43]. The variable of  $m$  symbolizes the financial liquidity in an economy. The variable of  $\mu$  symbolizes the consumption in an economy. The variable of  $\alpha_p$  symbolizes the enforcement savings, which come from the citizens and small and medium-sized enterprises. The variable of  $x_m$  symbolizes the condition of financial liquidity in an economy. The variable of  $c_m$  symbolizes the velocity of financial liquidity increases or decreases [17]. The

variable of  $c_\alpha$  symbolizes the velocity of escaped savings. Therefore, the variable of  $c_y$  symbolizes the term the cycle of money. Thereupon, the cycle of money shows the level of the dynamic of an economy and its robustness [8,44-51].

Then, we have the following basic principles about the cycle of money:

The citizens, the small and the middle-sized enterprises substitute the services and the property of the companies which save their money and do not invest them or consume it proportionally in the economy. Thereupon, the companies of the controlled transactions are the main cause of the escape savings.

The escaped savings are responsible for the decline of the economic dynamic of the economy. The key point of escape savings is that the companies of controlled transactions of transfer pricing are responsible for not reenter of this amount of money in the market. This situation causes a lack of financial liquidity in an economy.

The substitution of controlled transactions is not substituted from the citizens and the small and middle size companies when there is not plausible to offer the same added value to the products and the services. This case happens especially in the instance of factories, research centers, etc. Therefrom, these cases in the appropriate tax policy should be taxed as uncontrolled transactions independently if they participate in controlled transactions (using the fixed length principle).

The enforcement savings are responsible for the high economic dynamic of the economy. The velocity of financial liquidity shows how rapidly the economy's robustness grows or declines accordingly. Then is an index for how well structured any economy is.

The velocity of escaped savings shows how rapidly the non-return savings are lost from the market, or by the lack of investments, or by the lack of consumption. The cycle of money represents the condition of the economy. The level of a well-structured tax system, and in general the dynamic of the economy.

Controlled transactions in the theory of the cycle of money are considered not only the cases of transfer pricing, but any kind of administration of profits and losses to avoid taxation. Uncontrolled transactions in the theory of the cycle of money are the case of the commercial

activity of citizens, small and medium-sized enterprises, factories, research centers, and any kind of commercial activity that cannot substitute by the companies of controlled transactions. The fixed length principle tackles issues subjects like the case cycle of money. But, this doesn't mean that restriction must apply the fixed length principle as the cycle of money is more widely theory which exceeds the transfer pricing scope.

Therefrom, we obtain that the cycle of money grows when there is a tax system like the case of the fixed length principle which permits the low

taxation of uncontrolled transactions and the higher taxation of controlled.

Moreover, there are three basic impact factors of rewarding taxes. The rewarding taxes are the only taxes that have an immediate and important role in the market of any economy. These factors are affiliated with education, with the health system of each society, and with the rest relevant structural economic factors of the prior two impact factors. This issue is illustrated in the next scheme:

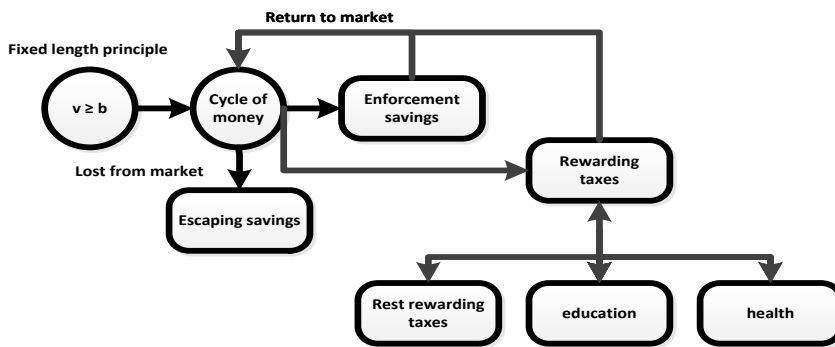

Figure 2. The cycle of money with rewarding taxes.

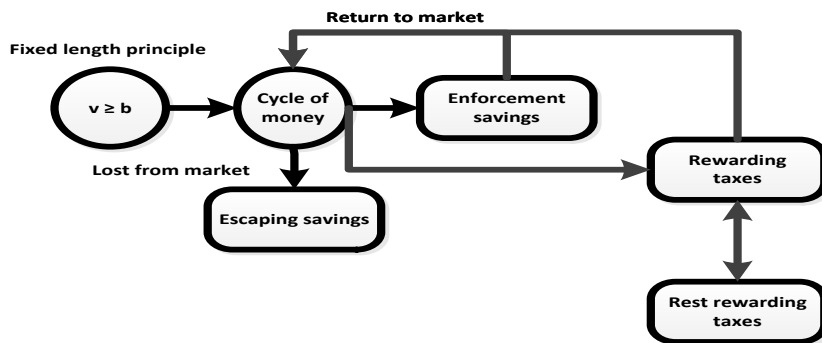

Figure 3. The cycle of money only with the impact factor of rest rewarding taxes.

The tax system is included all the tax factors and all the rewarding tax factors.

It is concluded from the previous scheme that we have the case of only one impact factor, which is about the rest rewarding taxes. Therefore, it can proceed to mathematical and quantity analysis of the cycle of money in the case of rewarding taxes.

#### IV. DEFINITION AND MATHEMATICAL APPROACH OF THE CYCLE OF MONEY WITH AND WITHOUT THE IMPACT FACTOR OF THE REST REWARDING TAXES

For the mathematical approach to the cycle of money we use the prior subject to the next conditions which are about the rewarding taxes:

$$\alpha_p = \alpha_r + \alpha_n \cdot h_n + \alpha_m \cdot h_m, \quad (15)$$

$$\alpha_r \geq \alpha_n \cdot h_n \geq \alpha_m \cdot h_m, \quad (16)$$

Some impact factors, which are  $\alpha_p$  which is also demonstrated in (15), moreover the variables  $\alpha_r$ ,  $\alpha_n$ ,  $h_n$ ,  $\alpha_m$ , and  $h_m$ . The variable  $\alpha_r$  symbolizes the impact factor of the rest rewarding taxes. The symbol of  $\alpha_n$  is the impact factor of education and any technical knowledge. The symbol of  $\alpha_m$  is about the impact factor of health anything relevant and supportive of this issue. The symbol of  $h_n$ , and the  $h_m$ , are the coefficients of the education and the health impact factor accordingly. Therefore, we use (1) to (10) and the next table for the coefficients of the values of the cycle of money with and without some impact factors of the rewarding taxes. Then, we have that:

TABLE I. COMPILING COEFFICIENTS.

Factors	Values	Values
$\alpha_s$	0.6	0.6
$\alpha_t$	0.7	0.7
$\mu$	0.9	0.9
$\alpha_r$	0.4	-
$\alpha_n \cdot h_n$	-	-
$\alpha_m \cdot h_m$	-	-

The generator of this procedure used the coefficients which appeared in the previous table. Therefrom, the factors have an upper limit of 1, and a lower limit of 0, but  $s$  and  $\tilde{s}$  are plausible to receive values greater than one as their mathematical structure allows this. After 461 iterations extracted the following diagram:

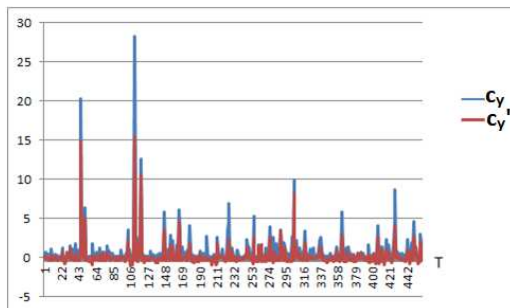

Figure 4. Comparison of the cycle of money with and without the impact factor of rest rewarding taxes.

In the previous scheme, an economy with structural problems has a lower cycle of money, showing that the distribution of money is lower.

Therefore, this economy would have lower consumption and lower investments.

## V. CONCLUSION

It is concluded that an economy with structural problems has a lower economic dynamic, in contradiction with an economy without this problem. This means that the taxes of this economy are not returned to the market. Thence, the consumption and the investments of this economy would be lower. Then, an economy without taxes will be in a lower dynamic than an economy that has the rest rewarding taxes. This means that as most taxes have a negative impact on the economy the rest rewarding taxes have a positive effect on the economy, as they return to the economy, for consumption and investments. This is the difference in general between the three rewarding taxes (rest-structural taxes, education taxes, and health taxes), and the taxes. This analysis showed that the case of the rest (structural) rewarding taxes helps the economy.

## REFERENCES

- [1] Acs, Z., Åstebro, T., Audretsch, D., & Robinson, D. T. (2016). Public policy to promote entrepreneurship: a call to arms. *Small business economics*, 47, 35-51.
- [2] Altman, M. (2008). Behavioral economics, economic theory and public policy. *Economic Theory and Public Policy (June 27, 2008)*.
- [3] Androniceanu, A., Gherghina, R., & Ciobănașu, M. (2019). The interdependence between fiscal public policies and tax evasion. *Administratie si Management Public*, (32), 32-41.
- [4] Anguera-Torrell, O., Aznar-Alarcón, J. P., & Vives-Perez, J. (2021). COVID-19: Hotel industry response to the pandemic evolution and to the public sector economic measures. *Tourism Recreation Research*, 46(2), 148-157.
- [5] Bakaki, Z., & Bernauer, T. (2018). Do economic conditions affect public support for environmental policy?. *Journal of Cleaner Production*, 195, 66-78.
- [6] Bourdin, S., & Nadou, F. (2018). French Tech: A new form of territorial mobilization to face up to global competition?. In *Annales de geographie* (Vol. 723724, No. 5, pp. 612-634). Armand Colin.
- [7] Challoumis C. (2018). Analysis of the velocities of escaped savings with that of financial liquidity. *Ekonomski signali*, 13(2), 001-014.
- [8] Challoumis, C. (2018). Identification of Significant Economic Risks to the International Controlled Transactions. *Economics and Applied Informatics*, 2018(3), 149–153.
- [9] Challoumis, C. (2018). Methods of controlled transactions and the behavior of companies according to the public and tax policy. *Economics*, 6(1), 33-43.
- [10] Challoumis, C. (2018). The impact factor of health on the economy using the cycle of money. *Bulletin of the Transilvania University of Brașov, Series V: Economic Sciences*, 11(60).



- [11] Challoumis, C. (2018). The Keynesian theory and the theory of cycle of money. *Hyperion Economic Journal*, 6(3), 3-8.
- [12] Challoumis, C. (2018). The Role of Risk to the International Controlled Transactions. *Economics and Applied Informatics*, 2018(3), 57–64.
- [13] Challoumis, C. (2019). Journal Association “SEPIKE” Edition 25, October, 2019. *Journal Association SEPIKE*, 12-21.
- [14] Challoumis, C. (2019). The arm’s length principle and the fixed length principle economic analysis. *World Scientific News*, 115(2019), 207–217.
- [15] Challoumis, C. (2019). The cycle of money with and without the escaped savings. *Ekonomski signali*, 14(1), 089-099.
- [16] Challoumis, C. (2019). The Impact Factor of Education on the Public Sector and International Controlled Transactions. In *Paksom Conference*, 2019, 151-160.
- [17] Challoumis, C. (2019). The RBQ (Rational, Behavioral and Quantified) Model. *Ekonomika*, 98(1), 6-18.
- [18] Constantinos, C. (2019). Theoretical analysis of fuzzy logic and QE method in economics. *Вестник Балтийского федерального университета им. И. Канта. Серия: Гуманитарные и общественные науки*, (1), 59-68.
- [19] Challoumis, C. (2019). Transfer pricing methods for services and the policy of fixed length principle. *Economics and Business*, 33(1), 222-232.
- [20] Challoumis, C. (2020). Analysis of the Theory of Cycle of Money. *Acta Universitatis Bohemiae Meridionalis*, 23(2), 13–29.
- [21] Challoumis, C. (2020b). Impact Factor of Capital to the Economy and Tax System. In *Paksom Conference*, 2020, 195–200.
- [22] Challoumis, C. (2020). The Impact Factor of Costs to the Tax System. *Journal of Entrepreneurship, Business and Economics*, 8, 1-14.
- [23] Challoumis, C. (2020). The Impact Factor of Education on the Public Sector–The Case of the US. *International Journal of Business and Economic Sciences Applied Research (IJBESAR)*, 13(1), 69-78.
- [24] Challoumis, C. (2022). Chain of cycle of money. *Acta Univ. Bohem. Merid.*, 24(2), 49-74.
- [25] Challoumis, C. (2021). Index of the cycle of money–The case of Greece. *International Journal of Business and Economic Sciences Applied Research (IJBESAR)*, 14(2), 58-67.
- [26] Challoumis, C. (2021). Index of the Cycle of Money - The Case of Latvia. *Economics and Culture*, 17(2), 5–12.
- [27] Challoumis, C. (2021). Index of the Cycle of Money: The Case of Serbia. *Open Journal for Research in Economics*, 4(1).
- [28] Challoumis, C. (2021). Index of the cycle of money–The case of Thailand. *Chiang Mai University Journal of Economics*, 25(2), 1-14.
- [29] Challoumis, C. (2021). Index of the Cycle of Money – the Case of Ukraine. *Актвал'ни Проблеми Економіки = Actual Problems in Economics*, (243/244), 102-111.
- [30] Challoumis, C. (2021). Index of the cycle of money - the case of Bulgaria. *Economic Alternatives*, 27(2).
- [31] Challoumis, C. (2021). Mathematical background of the theory of cycle of money. *SSRN Electronic Journal*.
- [32] Challoumis, C. (2021). Index of the cycle of money–The case of Greece. *International Journal of Business and Economic Sciences Applied Research (IJBESAR)*, 14(2), 58-67.
- [33] Challoumis, C. (2022). Index of the cycle of money–The case of Poland. *Research Papers in Economics and Finance*, 6(1), 72-86.
- [34] Challoumis, C. (2022). Structure of the economy. *Actual Problems of Economics*, 247(1).
- [35] Alves, C., & Kvangraven, I. H. (2020). Changing the narrative: Economics after Covid-19. *Review of Agrarian Studies*, 10(2369-2020-1854).
- [36] Cruz-Castro, L., & Sanz-Menéndez, L. (2016). The effects of the economic crisis on public research: Spanish budgetary policies and research organizations. *Technological Forecasting and Social Change*, 113, 157-167.
- [37] Goldsztejn, U., Schwartzman, D., & Nehorai, A. (2020). Public policy and economic dynamics of COVID-19 spread: A mathematical modeling study. *PLoS one*, 15(12), e0244174.
- [38] Haigh, Y. (2020). Increasing complexities: Teaching public policy in the age of discontent. *Teaching Public Administration*, 38(1), 24-45.
- [39] Herzog, B. (2021). Sustainable consumer tax evasion theory under information inattention. *Sustainability*, 13(2), 562.
- [40] John, P. (2018). Theories of policy change and variation reconsidered: a prospectus for the political economy of public policy. *Policy sciences*, 51(1), 1-16.
- [41] Khadzhyradieva, S., Hrechko, T., & Smalskys, V. (2019). Institutionalisation of behavioural insights in public policy. *Public Policy and Administration*, 18(3), 95-113.
- [42] Lucchese, M., & Pianta, M. (2020). The coming coronavirus crisis: What can we learn?. *Intereconomics*, 55(2), 98-104.
- [43] Maestre-Andrés, S., Drews, S., & van den Bergh, J. (2019). Perceived fairness and public acceptability of carbon pricing: a review of the literature. *Climate Policy*, 19(9), 1186-1204.
- [44] Martin, A. S., & Freeland, S. (2021). The advent of artificial intelligence in space activities: New legal challenges. *Space Policy*, 55, 101408.
- [45] Maxwell, J. A. (2020). The value of qualitative inquiry for public policy. *Qualitative Inquiry*, 26(2), 177-186.
- [46] Ndalamba, K. K. (2019). An exploration into the problematic public policies and the leadership challenge for socio-economic transformation in South Africa. *International Journal of Excellence in Government*.
- [47] OECD, E. (2020). SME Policy Index - Eastern Partner Countries 2020 Assessing the Implementation of the small Business Act for Europe. In *OECD*.
- [48] Peres, M. F. P., Oliveira, A. B., Sarmiento, E. M., Rocha-Filho, P. S., Peixoto, P. M., Kowacs, F., ... & Bensenor, I. J. (2020). Public policies in headache disorders: needs and possibilities. *Arquivos de Neuro-Psiquiatria*, 78, 50-52.
- [49] Reeves, P., Edmunds, K., Searles, A., & Wiggers,

- J. (2019). Economic evaluations of public health implementation-interventions: a systematic review and guideline for practice. *Public Health*, 169, 101-113.
- [50] Shamah-Levy, T., Romero-Martínez, M., Cuevas-Nasu, L., Méndez Gómez-Humaran, I., Antonio Avila-Arcos, M., & Rivera-Dommarco, J. A. (2019). The Mexican national health and nutrition survey as a basis for public policy planning: Overweight and obesity. *Nutrients*, 11(8), 1727.
- [51] Sultana, A., Or Rashid, M. H., Akter Eva, S., & Sultana, A. (2020). Assessment of Relationship Among Regional Economic Development Policy. *Urban Development Policy and Public Policy. Sumerianz Journal of Economics and Finance*, 310.

## APPENDIX

A paradigm, and the general concept of the program:

```

as=0; at=0; xm=0; m=0; m1=0; ap=0; cm=0;
ca=0; cy=0; t=0;
while t<10
    t=t+1;
    if rand()<9
        as=0.6*rand();
    end
    if rand()<9
        at=0.7*rand();
    end
    if rand()<9
        m1=0.9*rand();
    end
    if rand()<9
        ap=0.8*rand();
    end
    am=0.2;
    a=(1-am)+as+at;
    m=m1+ap+am;
    xm=m-a;
    cm=xm/a;
    ca=xm/m;
    cy=cm-ca;
    tab=[a,xm,m,cm,ca,cy;tab];
end

```



# Innovative Management based on the Application of Internal Audit in the Public Sector of the Republic of Serbia

Jelena Vitomir<sup>1</sup>, Sonja Tomas-Miskin<sup>2</sup>, Goran Vitomir<sup>3</sup>, Slobodan Popović<sup>4</sup>

<sup>1</sup>Megatrend University in Belgrade, Belgrade, Serbia

<sup>2</sup>Belgrade Banking Academy, Belgrade, Serbia

<sup>3</sup>Nova Banka A.D., Banja Luka, Bosna and Hercegovina

<sup>4</sup>Faculty of Economics and Industrial Management in Novi Sad, Novi Sad, Serbia

<sup>1</sup>jelena.vitomir1@gmail.com, <sup>2</sup>sonjat984@gmail.com, <sup>3</sup>g.vitomir85@gmail.com,

<sup>4</sup>slobodan.popovic49@gmail.com

*Abstract*—Innovative management based on the real application of internal audit is gaining more and more importance within the functioning of a large number of heterogeneous companies. One of the most important segments of management is represented by public companies that, as part of management in the public sector of the Republic of Serbia, are increasingly introducing some of the innovative forms of management into their regular operations. One of the ways of realistic observation of management is the implementation of internal audit in the regular operations of public companies in the Republic of Serbia. The goal of the implementation of internal audit in the regular operations of public companies is to ensure the security of operations in all segments, all sectors and parts of the public company that introduced internal audit in regular operations. Internal audit work is carried out by highly professional personnel, who must be continuously educated and perfected so that the consequences of their activities are realistically visible to the top management of a public company.

**Keywords** - innovative management, internal audit.

## I. INTRODUCTION

Innovative management based on the real application of internal audit is gaining more and more importance within the functioning of a large number of public companies in the Republic of Serbia. One of the ways to improve

the overall operations of public companies is the decision of the top management to introduce an internal audit into their regular operations. It is a strategic decision introduced with the aim of improving the general level of management and business security of public companies operating within the public sector through the application of internal audit.

The existence of strategic planning in the business of public enterprises is one of the right answers to the existence of a real crisis. As part of such an observation, it is necessary to pay attention to the real functioning of financial institutions and banks, in addition to the functioning of the public sector, because it is an inseparable part of the functioning of the economic system, which top management should pay attention to in their real operations. In this way, the business itself becomes more economically realistic and essentially adapted to the conditions prevailing in the environment of the public sector and commercial banks. Essential business operations require the application of internal audit as a control mechanism, through the application of which the functioning of a large number of heterogeneous legal entities in one country can be improved. Such an observation comes to a great expression in the conditions of economic crisis, war events, natural disasters, etc.

Business in the public sector of the Republic of Serbia managed by the top management should be seen as real management in which the real value and solvency of the capital is to be preserved and that over a long period of time. One of the ways to improve management is the system of introducing internal audits into regular business, which is of particular importance in business in conditions of economic crisis, breakdowns in the economy, the existence of losses on global markets, the existence of war events, lack of raw materials, rising prices of raw materials, public business sectors and public companies that are dominant in the economy when it comes to meeting the public needs of the population, etc.

The development of the public sector in the Republic of Serbia is essentially measured by the existence of real results of the public sector's operations, and this observation should not be in the short term but in a longer period of time. Essentially, the top management as well as the state should ensure the real growth of management functions in the public sector, which is associated with the existence of numerous risks, and the application of internal audit should prevent the occurrence of manipulations in the management of the mentioned companies.

The processes in which a public enterprise can be found as well as the business situations in which the entire public sector operates are connected with the real existence of risks at all levels of business [1-5], both in the public sector and in the relations between the public sector and the real economy.

The overall observation of making valid business decisions of top management in the public sector in the conditions of continuous economic and financial crisis [6-9] is connected with the existence and detection of public sector business risks. In such conditions, the public sector operates and it essentially strives to develop, and internal audit can help it in this real operation if it is significantly implemented [10-11].

Such, that is, the realistic approach of top management in the business of public companies cannot be viewed separately from the establishment of all control functions [12-15].

## II. THE EXISTENCE OF RISIKS IN THE ECONOMIC ENVIRONMENT OF THE PUBLIC SECTOR IN THE REPUBLIC OF SERBIA

The risk of insolvency of the economic collapse of public companies, the relation of the financial environment, which is measured by the activities of commercial banks, is most often expressed in three forms, where each qualification of insolvency contains a description of the relationship between insolvency (solvency) and losses.

Thus, a commercial bank can be:

- 1) solvent and without losses,
- 2) solvent with a loss, and
- 3) insolvent with a loss.

The presentation of the economic environment of the public sector is given in Table I.

TABLE I. ELEMENTS OF THE SOLVENCY BALANCE SHEET OF A COMMERCIAL BANK M REQUIREMENTS TO SEEDLINGS.

Current reserves and non-profit assets	Deposits and other liabilities
Profitable assets	Share capital of the bank

## III. BALANCE SHEET AND BUSINESS OF COMMERCIAL BANKS WHICH ARE THE ECONOMIC ENVIRONMENT OF THE PUBLIC SECTOR

Balancing and operations of commercial banks is one of the important activities that is continuously carried out by the bank's top management.

At the same time, it should be noted that the top management of a bank that wants to do business with the public sector should introduce controls within its operations, and it should also be said that the public sector introduces controls and audits in its operations, all with the aim of achieving optimal business results.

The presentation of the economic development of public enterprises is given in the form of Table II.

TABLE II. ELEMENTS OF THE LOSS AND SOLVENCY BALANCE SHEET OF A COMMERCIAL BANK

Assets	Passive
Current reserves and non profit assets	Share capital of the bank
Profitable assets	Deposits and other liabilities
Bank loss	

#### IV. FORMATION OF WORK FLOW AND FUNCTIONING OF INTERNAL AUDIT IN THE PUBLIC SECTOR OF THE REPUBLIC OF SERBIA

The managerial effects of top management in the functioning of the public sector in the Republic of Serbia should be aimed at realizing the effects of general management in public enterprises.

Then all management functions in public enterprises can be improved in a real and essential way, so the effects of management decisions are visible in a short time after the general decision to implement internal audit in the real operations of the public enterprise.

The authors presented a possible overview of internal audit activities in the real functioning of the public sector in the Republic of Serbia by presenting the most frequently observed steps in the application of internal audit.

- audit planning,
- determining control objectives,
- weakness identification system in the company,
- identification of internal control,
- assessment control,
- test,
- conclusion, and
- internal auditor's report.

#### V. APPLICATION OF A CLEAR BUSINESS DECISION IN TOP MANAGEMENT DECISION-MAKING

The importance of making a rational business decision by the top management in public companies should be seen as one of the important jobs that it performs as a permanent process and permanent management activity in the company.

The process of rational business decision-making is of particular importance for the functioning and operations of companies that perform their majority of business in public

activities where the needs of a wide range of the population are met.

Public service can be seen as an activity that does not have a particularly emphasized requirement for making a profit compared to other profit-making activities that depend on the great influence of factors such as the demands of capital owners, shareholders, banks, etc.

The authors emphasize that the process of making a rational business decision begins with the adoption of a valid management decision by the top management, and what the authors emphasize in this paper is the fact that these decisions must have a built-in level of control that can be achieved in different ways, and the way that is shown in this work is the application of internal audit in the operations of the public sector of the Republic of Serbia.

The implementation of a valid business decision in all parts of the company is of great importance to be implemented immediately because any delay in its implementation costs the public company, but also the users of public funds, the taxpayers who, in the final sense, founded the public company to do the work for their account and needs public work, i.e. work of public importance.

In the work of internal audit, a whole series of auxiliary means helps, and the authors point out that the application of the achievements of the IT sector in a public company can help in faster implementation and making of valid business decisions of the top management.

Therefore, the application of IT techniques and software solutions can improve the management of the public sector in the Republic of Serbia in the short term.

An innovative way of management includes, among other things, management in some non-standard situations, such as for example: management in conditions of an almost declared pandemic, in conditions of crisis action (such as emergency situations, expected war events, etc.).

All this imposes the need to turn management functions by those who make management decisions that are essentially non-standard management decisions. In such circumstances, innovative managers are more difficult to come to the fore because they tend to introduce a whole set of innovations that are

important for management in heterogeneous companies.

Innovations in the management of various spheres of social life become a significant lever for the successful long-term development of the business of very heterogeneous legal entities in one economy. At the same time, innovation should be seen as one of the main resources for creating added value in the economy of a country, but also as a state in which management using an innovative approach implies the application of greater control in the management of legal entities. Precisely because of the facts presented in this paper, the authors emphasized the importance of management, which implied the application of internal audit with the aim of reducing the general risk in management.

Such application can substantially improve the management functions of top management and give positive results in a very short time. The situation at the global level of management requires that a very large number of heterogeneous legal entities, primarily due to the changed global circumstances, each decide in their own way to introduce a greater number of innovations. In this paper, the authors highlight the use of a control mechanism by applying internal audit, because in this way, overall business risks are reduced in the short term, and in such innovations, the application of internal audit means an improvement in overall management.

Questions of how to achieve innovations, how to introduce them in the business of management in legal entities is a process to which no one has a unique and universal answer. This paper indicates a real possibility of management that can be improved by an innovative approach using internal audit. The work of internal auditors is reflected in the writing of the audit report. They give recommendations that top management can adopt or not.

The authors of the paper emphasize the importance of accepting the internal auditor's recommendations, because their application can significantly improve overall management, which was the goal of drawing attention to this essentially innovative approach.

## VI. CONCLUSION

Management in public companies in the Republic of Serbia is associated with the

existence of a large number of risks. Reducing business risk is a real activity that every top management strives for, including the top management of a public company. In order to reduce the risk to the overall operations of the public company, the top management introduces a number of controls. In this paper, the authors presented the flow of internal audit as a model of internal audit implementation that contains most of the steps that internal auditors must fulfill in their work.

It is a continuous activity of internal auditors as well as top management in the business of the public sector in the Republic of Serbia. In addition to the prominent importance of risk assessment, top management should also consider the bad business decisions it had in the previous period, then the existence of losses shown in the financial statements, as well as the current existence of illiquidity in the work of the public company managed by top management. The author's contribution is essentially emphasizing the importance of the implementation of internal audit within the framework of the existence of control mechanisms, which he introduces into regular business with the aim of reducing the negativity of business.

## REFERENCES

- [1] Vitomir, J., Popović, S., Tomas-Miskin, S. (2022). Macro-economic respect for heterogeneous environmental factors in companies engaged in the production of healthy safe food. In *Proceedings, 26 International Eco-Conference and 12 Safe Food, Novi Sad, 21-23 September 2022* (pp. 281-287). Novi Sad: Ecological Movement of Novi Sad.
- [2] Arnautović, I., Davidov, T., Nastić, S., & Popović, S. (2022). The importance of business decision-making of top management in an agricultural company that uses the practical application of new approaches to software solutions in the it sector in the Republic of Serbia. *Poljoprivredna tehnika*, 47(2), 51-57.
- [3] Tomas-Miskin, S. (2021). Financial crisis and its general impact on developments within the banking sector of Bosnia and Herzegovina. *Temel-I.J.*, 5.(2), 18-25.
- [4] Tomaš-Miskin, S. (2021). Doctoral dissertation, Strategic performance management of banks in Bosnia and Herzegovina in the conditions of the financial crisis, working version.
- [5] Radović, M., Vitomir, J. & Popović, S. (2019). The Importance of Implementation of Internal Audit in Enterprises Founded by the Republic of Serbia, *Lex Localis - Journal of Local Self-Government*, 17(4), 1001-1011.
- [6] Radović, M., Vitomir, J. & Popović, S. (2021). Impact of internal control in enterprises founded by local self-government units: the case of Republic of Serbia.

- Inzinerine Ekonomika-Engineering Economics*, 32(1), 82-90.
- [7] Popović, S., Novaković, S., Đuranović, D., Mijić, R., Grublješić, Ž., Aničić, J., & Majstorović, A. (2017). Application of international accounting standard-16 in a public company with predominantly agricultural activities. *Economic Research - Ekonomska Istraživanja*, 30(1), 1850-1864.
- [8] Chen, R. (2019): Internal Control Audit Fee and Internal Control Audit Quality—Evidence from Integrated Audits, *Open Journal of Business and Management*, 7, 292-311.
- [9] Popović, S., Majstorović, A., Grublješić Ž. (2015). Valuation of facilities in use and application of international accounting standards, *Actual problems of economics*, 3(165), 379-387.
- [10] Popović, S., Novaković, S., Đuranović, D., Mijić, R., Grublješić, Ž., Aničić, J., Majstorović, A. (2017): Application of international accounting standard-16 in a public company with predominantly agricultural activities. *Economic Research - Ekonomska Istraživanja*, 30(1), 1850-1864.
- [11] Radović, M., Vitomir, J., Laban B., Jovin, S., Nastić S., Popović, V., Popović, S. (2019). Management of joint-stock companies and farms by using fair value of agricultural equipment in financial statements on the example of IMT 533 tractor, *Economics of Agriculture*, 66(1), 35-50.
- [12] Vitomir, J., Tomaš-Miskin, Laban, B. (2019): Management of business results in medium-sized agricultural enterprises and individual farms in relation to the movement of the height of wages, *Economics of Agriculture*, 66(3), 811-822.
- [13] Vitomir, J., Tomaš-Miskin, S., Ivić, M., Popović, S. (2020): Implementation of the Tender by the Municipal Service Administration from the Aspect of Management in the Municipalities of the Republic of Serbia, *Lex Localis – Journal of Local Self-Government*, 8(3), 469-486.
- [14] Arnautović, I., Davidov, T., Nastić, S., Popović, S. (2022). The Importance of Making a Rational Business Decision of Top Management in Agricultural Companies in the Republic of Serbia, *Agricultural Engineering*, 47(3)1-8.
- [15] Vitomir, G., Popović, S., Vranić, I., Vukeljić, V., Božović, D. (2022). Cooperation of forensic accounting and forensic audit in food production companies, , In *Proceedings, 26 International Eco-Conference and 12 Safe Food, Novi Sad, 21-23 September 2022* (pp. 275-281), Novi Sad: Ecological Movement of Novi Sad...





# Features of Preschoolers' Use of Digital Media: New Socio-Cultural Context

Rubtsova Olga<sup>1</sup>, Klopotova Ekaterina<sup>2</sup>, Smirnova Svetlana<sup>3</sup>, Sorokova Marina<sup>4</sup>

<sup>1,2,3,4</sup>Moscow State University of Psychology & Education, Moscow, Russia

<sup>1</sup>ovrubsova@mail.ru, <sup>2</sup>klopotova@yandex.ru, <sup>3</sup>smirnovasy@mgppu.ru, <sup>4</sup>sorokovamg@mgppu.ru

## Keywords

Information revolution, digital media (devices), preschool age, social situation of development

## Summary

Under the IV Information Revolution, children get introduced to gadgets extremely early and their daily screen time is steadily increasing. The mediators between the child and digital technologies are parents. Therefore, it is parents' responsibility to convey to the child the cultural way of using an object - a digital device/gadget. However, many parents experience serious difficulties in organizing their children's interaction with gadgets. Despite the importance of the problem, the research, devoted to various aspects of preschoolers' use of technologies, is still rather scarce. The relevance of such research is due to the need of constructing efficient means of child-adult cooperation, mediated by new digital signs.

In 2022 Moscow State University of Psychology and Education (Moscow, Russia) launched a research project, aimed at revealing the peculiarities of the social situation of development (L.S. Vygotsky) of contemporary preschoolers under the digital transformation. The project included an empirical study, focusing on parents' position in relation to preschoolers' use of digital media, that was conducted by the "Center for Interdisciplinary Research of Contemporary Childhood" (childresearch.ru).

In the framework of the study a questionnaire "Child-Adult Interactions Under the Digital Transformation", which included 19 questions, was elaborated. The data was collected in different social networks via a Google-form. The

study sample included 6376 parents of children aged from 2 to 7 years old (from the Russian Federation). Quantitative analysis of the data was conducted by the means of descriptive statistics, while calculations were made in SPSS V23.

The empirical data revealed some tendencies in the use of digital devices by contemporary Russian preschoolers. First, Russian preschoolers more often get access to "adult" devices, such as smartphones, computers, or tablets, rather than to gadgets, specifically designed for children (IoToys, books with QR-codes). The data also showed, that, while providing access to gadgets, parents of preschoolers expect a developmental and educational effect. However, while organizing their children's interaction with gadgets, most parents rely on the child's preferences and their own curiosity, rather than on professional recommendations.

The controversy stresses the importance of elaborating guidelines for parents of preschoolers, which could be used for organizing children's daily interactions with digital media. The aim of the guidelines is not just to introduce screen time norms, but rather to inform parents about the most efficient ways of constructing developing environments, mediated by new digital tools.

## References

- [1] Klopotova E.E., Kuznetsova T.Yu. (2017). The use of «serious gaming» in educational work with children. *Journal of Modern Foreign Psychology*, 6(4), 41-45.
- [2] Klopotova E.E., Smirnova S.Y., Rubtsova O.V., Sorokova M.G. (2022). Accessibility of Digital Devices to Preschool Children: Differences in Parents' Positions. *Counseling Psychology and Psychotherapy*, 30(2), 109-125.

- [3] Rubtsova O.V. (2019). Digital Media as a New Means of Mediation (Part One). *Cultural-Historical Psychology*, 15(3), 117-124.
- [4] Rubtsova O.V. (2019). Digital Media as a New Means of Mediation (Part Two). *Cultural-Historical Psychology*, 15(4), 100-108.
- [5] Smirnova E.O., Matushkina N.Y., Smirnova S.Y. Virtual Reality in Early and Preschool Childhood. *Psychological Science and Education*, 23(3), 42–53.
- [6] Smirnova S.Y., Klopotova E.E., Rubtsova O.V., Sorokova M.G. (2022). Features of Preschoolers' Use of Digital Media: New Socio-Cultural Context. *Social Psychology and Society*, 13(2), 177-193.

# Training Pre-service Teachers for using Educational Software in Order to Improve the Quality of the Mathematics Teaching in Primary Education

Radoslav Božić<sup>1</sup>, Ivica Nikolić<sup>2</sup>, Violeta Petković<sup>3</sup>

<sup>1,2,3</sup>Faculty of Pedagogy, Educons University, Sremska Kamenica, Novi Sad, Serbia

<sup>1</sup>radoslav.bozic@gmail.com, <sup>2</sup>profilov@gmail.com, <sup>3</sup>violeta.petkovic@gmail.com

## Keywords

Educational software, mathematics, visualization

## Summary

The application of mathematics is present in different disciplines and that is one of the most important reasons for the significance of the mathematics education at all levels of education. However, a prerequisite for the successful study of mathematical contents in secondary and higher levels of education is the acquisition of basic mathematical concepts and their properties, which is being realized during the primary education [1]. Bearing in mind the foregoing, the teachers in primary education have a very important, but not easy task – to introduce the students into elementary mathematical concepts, without defining them [2].

However, the teachers face the numerous challenges in presenting elementary mathematical concepts and guiding the students through the learning process [2-4]. One of the most common challenges is presenting the geometric concepts, as well as introducing the students with the properties of the geometric objects [2]. For a successful analysis of the geometric object properties, an adequate visualization is necessary. In order to visualize geometric objects, the teachers usually use

sketches and 3D models, which can be very helpful [5].

With the development of the mathematical software, new possibilities in visualization of the geometric contents have appeared. One of the most commonly used educational software, adequate for the visualization of geometric object, but also for work with different mathematical contents, is *GeoGebra*. This software is free and easy to use, which enable the students in primary education to use it, with the help of the teacher [5-7]. Visualization of the geometric contents can be realized if this software is used by a teacher, for presenting the contents to the students, but, using the software by the students (to the extent that this is possible) contributes to greater students' engagement and the development of their digital competencies [8].

For the successful application of this software in teaching and learning mathematics, it is necessary for the teacher to be well trained in using this software. At the Faculty of Pedagogy, Educons University, pre-service teachers are being trained in using this software within the course of Mathematics teaching methodology. This training includes the methodology approach in working with the primary school students within the *GeoGebra* software environment. The teachers must be very careful in using the software at this level of education, in terms of the

contents and the task selection, but also in terms of students' working within the software environment [9].

If used appropriately, taking into account the age of the students, *GeoGebra* software can help students to observe geometric objects in different ways and, also, to analyze the properties of the observed objects and the similarities, differences and connections between the different objects. The practice, but also the numerous research, has shown that the use of this, or similar mathematical software, with the students in secondary or higher education, have significant benefits in terms of the students' achievements in learning different mathematical contents [5,6,10]. It can be expected that the use of this kind of software can contribute to the primary school students' better achievements in learning mathematical contents, with the accent on the geometric contents.

## References

- [1] Božić, R., Hasić, A., Jovanova, B. and Romano, D. A. (2018). Geometrics Objects in the Final Grade of Middle Schools in B&H, Croatia, Macedonia, Montenegro, Serbia, and Turkey and Students' Progress of Geometrical Thinking which their Mathematical Curricula Enable. *IMVI Open Mathematical Educational Notes*, 8(2), 47-59.
- [2] Dunphy, E. (2009). Early childhood mathematics teaching: Challenges, difficulties and priorities of teachers of young children in primary schools in Ireland. *International Journal of Early Years Education*, 17(1), 3-16.
- [3] Ambrose, R. (2014). Initiating Change in Prospective Elementary School Teachers' Orientations to Mathematics Teaching by Building on Beliefs. *Journal of Mathematics Teacher Education*, 7, 91-119.
- [4] Shriki, A., & Patkin, D. (2016). Elementary school mathematics teachers' perception of their professional needs. *Teacher development*, 20(3), 329-347.
- [5] Korenova, L. (2017). GeoGebra in Teaching of Primary School Mathematics. *International Journal for Technology in Mathematics Education*, 24(3), 155-160.
- [6] Božić, R., Takači, Đ. & Stankov, G. (2019). Influence of dynamic software environment on students' achievement of learning functions with parameters. *Interactive Learning Environments*, 29(4), 655-669.
- [7] Zilinskiene, I. (2014). Use of GeoGebra in primary math education: a theoretical approach. *Lietvovs Matematikos Rinkinyys*, 55, 73-78.
- [8] Božić, R. (2019). *The application of modern technology in teaching and learning stereometry*. In: Mathematical Society of Serbia - Scientific conference "Research in Mathematics Education" Proceedings, Belgrade, Serbia.
- [9] Polly, D. (2014). Elementary School Teachers' Use of Technology During Mathematics Teaching. *Computers in the Schools*, 31:4, 271-292.
- [10] Zilinskiene, I., & Demirbilek, M. (2015). Use of GeoGebra in Primary Math Education in Lithuania: An Exploratory Study from Teachers' Perspective. *Informatics in Education*, 14(1), 127-142.

# Organizations of the Planetary Civilization: Change between the Organization of 2022 and 2092

Sergey Ivanov<sup>1</sup>

<sup>1</sup> Department of Management, School of Business and Public Administration, University of the District of Columbia, Washington, DC 20008, U.S.A.

<sup>1</sup>sivanov@udc.edu

## Keywords

Organizations, planetary civilization, management hierarchy, leadership

## Summary

The world of today is vastly different from the one 150 years ago. The organization of 1800 was fundamentally different than the organization of today. If one were to look at organizations, one would have noticed great fundamental changes [1].

Today, Musk (2021), Bezos (2018), and others state that the humanity may only have a short window to become a multi-planetary species for the survival of the human race. Musk (2021) argues that the growth of the population is one of the keys, as does Bezos (2018) envisioning trillions of human beings populating the Solar System.

Others, on the other hand, such as Chomsky (2022), Atomic Scientists (2022), warn that humanity may have soon reached the point of a complete destruction of the organized human life on Earth, citing the dangers of a possible nuclear war, environment, and other global human-created troubles. Even Musk's father (2022) admits that Elon Musk thinks he is behind, and should have been at today's point five-years ago, discussing Tesla and SpaceX's Mars-ambitions. Discussing a 1-million city on Mars, Musk (2021) goes further and suggest direct democracy, instead of today's quasi-unknown societal structure, that has its democratic aspects,

but is also filled with totalitarian structures in organizations.

Each developmental shift in the civilization warrants different structure of the organization and society. Another shift is rapidly approaching. The organization and society of 2092 will fundamentally change again, and will be drastically different from the organization of today, filled with new challenges and opportunities.

## Acknowledgement

I am grateful to many intellectual and moral giants of thought and humanity with whom I have been so privileged to meet and work, including such incredible individuals, Professors and Drs. Makhlof, Carson, Jaques, Harvey, and many others who have contributed to my growth to begin discussing some areas of significance to organizations and possibly societies. I am also grateful to the community and comradeship of the University of the District of Columbia, in Washington DC, USA, and its absolutely amazing students, faculty, and members of the administration.

## References

- [1] Reagan, M. D. (1979). *The Visible Hand: The Managerial Revolution in American Business*. By Alfred D. Chandler Jr. (Cambridge, Mass.: Harvard University Press, 1977). *American Political Science Review*, 73(2), 580-581.
- [2] Deming, W. E. (1994). *The New Economics: for industry, government, education*. Cambridge, MA: MIT/CAES Press.

- [3] Deming, W. E. (1992). *Out of the Crisis*. Cambridge, MA: Massachusetts Institute of Technology.
- [4] Harvey, J. B. (1988). *The Abilene paradox and other meditations on management*. Jossey-Bass.
- [5] Ivanov, S. (2011). Why Organizations Fail: A Conversation about American Competitiveness. *International Journal of Organizational Innovation*, 4(1).
- [6] Ivanov, S. (2013). Defects in modern organizations: Field findings and discovery. *International Journal of Innovation, Management and Technology*, 4(2), 204.
- [7] Ivanov, S. (2015). Exposing myths of modern management: Innovation—identifying the problem. *Journal of Leadership and Management*, 1(3).
- [8] Ivanov, S. (2015). Exposing myths of modern management: Innovation—exploring a solution. *Journal of Leadership and Management*, 2(4).
- [9] Ivanov, S. (2015). The work of associations: A hidden dimension of all managerial hierarchies (bureaucracies). *Journal of Leadership and Management*, 2(4).
- [10] Ivanov, S. (2013). Defects in modern organizations: Field findings and discovery. *International Journal of Innovation, Management and Technology*, 4(2), 204.
- [11] Ivanov, S. (2011). US analyst predicts a nationwide Russian crisis in 2035-2040: It is not the US but Russia that may collapse... Again. *International Journal of Humanities and Social Science*, 1(15), 215-216.
- [12] Jaques, E. (1995). *Glossary of Key Terms in Requisite Organization*. Gloucester, MA: Cason Hall and Co.
- [13] Jacques, E. (1996). *Requisite Organization: A Total System for Effective Management Leadership for the 21st Century*. Cason Hall.
- [14] Jaques, E. (2002). *Social power and the CEO: Leadership and trust in a sustainable free enterprise system*. Greenwood Publishing Group.
- [15] Jaques, E. (2002, February). The Psychological Foundations of Managerial Systems: A General Systems Approach to Consulting Psychology. In *San Antonio, Texas: Midwinter Conference of the Society of Consulting Psychology*.
- [16] Jaques, E. (1998). On Leaving the Tavistock Institute. *Human Relations*, 51(3), 251-257.
- [17] Jacques, E. (1990). In Praise of Hierarchy—Harvard Business Review, 68(1), 127-133.
- [18] Jaques, E. & Cason, K. (1994). *Human Capability*. Rockville, MD: Cason Hall.
- [19] Jaques, E., & Clement, S. D. (1994). *Executive leadership: A practical guide to managing complexity*. John Wiley & Sons.
- [20] Jaques, E., Gibson, R. O., & Isaac, D. J. (1978). Levels of Abstraction in Logic and Human Action a Theory of Discontinuity in the Structure of Mathematical Logic, Psychological Behaviour, and Social Organization.
- [21] Gershenfeld, N. (2011). Physics of the future: how science will shape human destiny and our daily lives by the year 2100. *Physics Today*, 64(10), 56.
- [22] Stanley, M. (1974). *Obedience to Authority: An Experimental View*. New York, NY: Harper & Row Publishers, Inc.
- [23] Toffler, A. (1970). *Future Shock*. New York, NY: Random House, Inc.
- [24] Tesla, N. (2007). *Myth3ery Truly Yours, Nikola Tesla*. Radford, VA: Wilder Publications, LLC.
- [25] Orwell, G. (1961). *1984*. New York, NY: Signet Classic.
- [26] Peck, M. S. (1983). *People of the Lie: The Hope for Healing Human Evil*. New York, NY: Touchstone.
- [27] Fromm, E. (1955). *The Sane Society*. Greenwich, CT: Fawcett Publications.
- [28] Kardashev, N. S. (1964). Transmission of Information by Extraterrestrial Civilizations. *Soviet Astronomy*, 8, 217.

# The Human Development Index as a Function of the Measure of Human Development in Serbia with Reference to the Countries of the Region

Mirjana Štaka<sup>1</sup>

<sup>1</sup>Faculty of Economics, Banja Luka, Bosnia and Herzegovina

<sup>1</sup>mirjana.staka@gmail.com

## Keywords

Index, human development, factors, education.

## Summary

The Human Development Index (HDI), as one of the more complex composite indicators of the level of human potential and quality of life, is a combination of three dimensions (indicators, factors): life expectancy at birth, average number of years of life, education and expected number of years of schooling combined into a unique index of education and economic benefits expressed by production, i.e. GDP (gross domestic product) according to purchasing power. The same measures and average achievements in the field of health, education and standard of living are shown. The HDI was first developed in 1990 by the United Nations Development Program (UNDP) and was published as the Human Development Reports (HDR).

The paper is particularly concerned with a more perspective view of human development on the territory of Serbia and the countries of the region, with a number of socio-economic implications for the development policy of the observed countries. The special importance of the conducted research stems from the fact that in the Balkan countries, the factors identified at the beginning of the transition period were often marginalized in the creation of macroeconomic

policies, but in recent years there have been more and more positive developments in this regard.

## Acknowledgement

The scientific contribution of the research results can serve economic policy makers for other analyzes of the considered policy measures that reproduce the determinants of household consumption.

## References

- [1] Alkire, S., & Santos, M. E. (2010). Acute multidimensional poverty: A new index for developing countries. Human Development Research Paper 2010/11. UNDP, New York. *Econometrica: Journal of the Econometric Society*, 629-650.
- [2] Allen, R. G. (1936). Professor Slutsky's theory of consumers' choice. *The Review of Economic Studies*, 3(2), 120-129.
- [3] Anand, S. (2013). *Sustainable Human Development: Concepts and Priorities*. UNDP. Human Development Report Office 1994 Occasional Papers.
- [4] Engel, E. (1895). Die Productions- und Consumtionsverhältnisse des Königreichs Sachsen (1857). Wiederabgedr. *Derselbe, Die Lebenskosten belgischer Arbeiter-Familien früher und jetzt. Ermittelt aus Familien-Haushaltrechnungen und vergleichend zusammengestellt. Dresden.*
- [5] Engel, E. (1895). *Die Lebenskosten belgischer Arbeiter-Familien früher und jetzt*. C. Heinrich.
- [6] Paraguas, M. D. S., & Kamil, A. A. (2005). Model Selection of Meat Demand System Using the Rotterdam Model and the Almost Ideal Demand System (AIDS). *Journal of Modern Applied Statistical Methods*, 5(2), 26.





# The Elaboration of Computer Game System for the Measurement of Higher-Order Cognitive Skills by Middle-School Students

Evgeniya Gavrilova<sup>1</sup>, Elena Shepeleva<sup>2</sup>, Yulia Tokarchuk<sup>3</sup>

<sup>1,2,3</sup>Moscow State University of Psychology and Education, Moscow, Russia

<sup>1</sup>gavrilovaev@mgppu.ru, <sup>2</sup>shepelevaea@mgppu.ru, <sup>3</sup>tokarchukyua@mgppu.ru

## Keywords

The “PL-modified” computer game system, higher-order cognitive skills, decision making

## Summary

The present study focused on the testing of a special computer game system which entitled “PL-modified” as a measurement tool for the higher-order cognitive skills by middle-school students. The relevance of the present research task is determined by the practical requirements formed for the contemporary diagnostics that tends to stick to the usage of the modern computer technologies for the precise assessment of children’s cognitive potential [1,2].

The methodological basis of the present study grounds on the theory of developing education [3,4] by postulating that theoretical thinking plays the pivotal role in the cognitive development of junior-school students and, as a result, in their educational success at the very beginning. There are three key components of theoretical thinking process including the mental functions of the higher order (or the higher mental actions) such as analysis, planning, and reflection. Thus, these higher-order cognitive skills were at the research focus of the present study.

For the measurement of the skills a special computer game system “PL-modified” was elaborated. The whole computer system represented the game field with the design of 9x9

cells where the balls of different colors appeared. Three balls were displayed at each game turn. Participants had to move one ball by one mouse-click in a free space of the field in a way to build a vertical, horizontal or diagonal line of five or more balls with the same color. After such line of colored balls has been built, it completely disappeared and participant earned his points. The system was based on the game called “Lines” created by Gamos Company, but unlike the original version where the balls were displayed randomly, the present research version implied certain sequences due to a principle which might be changed in different cycles of the game in a hidden way by stimulating students’ reasoning about the possible regularity of how the balls are appearing each time. We assume that these sequences or so-called ‘rules’ of the balls’ (and students’ attempt to discover and use it while planning their moves) will booster the whole game process by raising the chances of participants to earn more points. So, the variable “analysis” was measured as a number of correctly chosen rules; the variable “planning” was assessed as a total number of game points; and the variable “reflection” was pointed as a number of balls at the last game move (as an indicator of the structure of the whole game field).

To control the interactions between the researched variables two samples of school students participated in the study. The first group was represented by the middle-school students (78 persons; age range 10-11 years) who learned

in a special school where the educational process was organized in accordance with the theory of developing education. The second group included school students of the same age from the standard school ( $N=58$  persons). All participants played four game sets each lasting for 10 minutes. After this procedure abstract intelligence measured by the Raven's Advanced Progressive Matrices [5] was controlled for each group.

The statistical analysis revealed the following results: 1) the group 1 outperformed the group 2 by the total number of game points (775 vs. 685,  $p = 0.05$ , respectively); 2) the total number of game points turned out to be impacted by the number of correctly chosen rules for the group 1, whereas the same level of game efficiency in the group 2 strongly correlated only with the level of intelligence. These empirical facts confirmed our assumption about the most significant impact of the variable analysis on the game efficiency (i.e., the variable planning) for those participants who is learning in accordance with the theory of developing education. 3) The SEM analysis confirmed the strong interactions between three researched variables in the group 1, but not group 2.

We discuss our study in terms of the prospects for computer games and other digital platforms as the measurement instruments in the field of psychology and education.

## References

- [1] Adachi, P. J., & Willoughby, T. (2013). More than just fun and games: the longitudinal relationships between strategic video games, self-reported problem solving skills, and academic grades. *Journal of youth and adolescence*, 42, 1041-1052.
- [2] Quiroga, M. A., Román, F. J., De La Fuente, J., Privado, J., & Colom, R. (2016). The measurement of intelligence in the XXI century using video games. *The Spanish Journal of Psychology*, 19, E89
- [3] Davydov, V. V. (1996). *Teoriya razvivayushchego obucheniya* [The theory of developmental education]. Moscow: Publ. INTOR.
- [4] Elkonin, D. B. (1966). *Vozrastne vozmozhnosti usvoeniya znaniy (mladshie klassy shkoly)* [Age-related opportunities for the assimilation of knowledge (primary school)]. Moscow, Prosveshchenie [Education].
- [5] Raven, Dzh. K., Kort, Dzh. Kh., Raven, Dzh. (2002). *Rukovodstvo k progressivnym matricam Ravena I slovarnym shkalam. Razdel 3. Standartnye progressivnye matritsy Ravena (Vklyuchaya parallelnye I plus versii)* [Guide to the Progressive Raven Matrices and Vocabulary Scales: Section 3: Standard Progressive Matrices (including parallel and plus versions)]. Moscow, Kogito-Tsentr.

# Profitability of Pakistan's Banking Sector and COVID-19

Syed Ahsan Ali Gardazi<sup>1</sup>, Shumaila Zeb<sup>2</sup>

<sup>1,2</sup>SZABIST, Islamabad, Pakistan

<sup>1</sup>ahsan.ali.gardazi@gmail.com, <sup>2</sup>shumaila.zeb@gmail.com

## Keywords

Profitability, Banks, COVID-19, Autoregressive Distributed Lag.

## Summary

The main of this study was to investigate the impact COVID-19 pandemic has had on the profitability of the banking sector of Pakistan.

The analysis was done using the Autoregressive Distributed Lag (ARDL) bounds testing approach to cointegration while the data was taken from open data source [1]. Banking sector's performance was proxied by the ratio of return on assets [2]. The factors that were included to determine banking sector's performance were Inflation, Liquid Capital, Non-Performing Loans, Large Scale Manufacturing [3], Market Treasury Bills rate and COVID 19.

This research has tried to encompass and visualize the time series data impacting the banking sector. It tried to incorporate the effect of COVID-19 on the profitability of the banking sector, all the while monitoring for banking sector specific and macroeconomic factors. Return on assets proxied the banking sector of Pakistan's profitability. Data availability was from Q4 2011 till Q1 2022. The data was analyzed using the Autoregressive Distributed Lag approach. The data was tested with some diagnostic tests to test the model's robustness and was found to be sufficient to explain the relationship between different interacting variables.

It has been found that rather than having a negative impact, COVID-19 seems to have had a positive impact on the profitability of the banking sector of Pakistan in the short run. The

findings of the current study are in contrast to other studies [4-7]. This contrasting research outcome may be because of policy measures taken by the Government of Pakistan and the State Bank of Pakistan. Some countries handled the COVID-19 crisis poorly and thus were left financially vulnerable [8], but in Pakistan due to a pro-active approach of government entities, adverse impact of the COVID-19 crisis seems to have been mitigated.

This positive impact maybe linked to the policies and programmes started by the government and the regulator to stimulate the economy in the face of the COVID-19 pandemic.

Future research can be expanded by adding policy decision data so that exact effect of each policy measure can be judged and accurately investigated.

## Acknowledgement

I am grateful to all of those with whom I have had the pleasure to work during this and other related projects especially Dr. Shumaila Zeb and Dr. Mubahsir Ali Khan.

## References

- [1] Pesaran, M. H., Shin, Y., & Smith, R. J. (2001). Bounds testing approaches to the analysis of level relationships. *Journal of applied econometrics*, 16(3), 289-326.
- [2] Tiko, J., Skvarciany, V., & Jureviciene, D. (2015). Drivers of bank profitability: Case of Latvia and Lithuania. *Intellectual Economics*, 9, 120-129
- [3] Hussain, F., Hyder, K., & Rehman, M. (2018). Nowcasting LSM growth in Pakistan. *SBP Research Bulletin*, 14(1), 1-16.
- [4] Barua, B., & Barua, S. (2021). COVID-19 implications for banks: evidence from an emerging economy. *SN Business & Economics*, 1, 1-28.

- [5] Elnahass, M., Trinh, V. Q., & Li, T. (2021). Global banking stability in the shadow of Covid-19 outbreak. *Journal of International Financial Markets, Institutions and Money*, 72, 101322.
- [6] Segerink, C., & Roszbach, K. (2021). Performance in the Banking Sector: An Evaluation of Bank Characteristics during the COVID-19 Pandemic.
- [7] Siregar, R. Y., Gunawan, A. H., & Saputro, A. N. (2021). Impact of the COVID-19 shock on banking and corporate sector vulnerabilities in Indonesia. *Bulletin of Indonesian Economic Studies*, 57(2), 147-173.
- [8] Demirgüç-Kunt, A., Pedraza, A., & Ruiz-Ortega, C. (2021). Banking sector performance during the COVID-19 crisis. *Journal of Banking & Finance*, 133, 106305.

# Impact of Financial Technology on Financial Inclusion and Financial Performance: Empirical Evidence from Financial Sector of Pakistan

Sehar Saleem<sup>1</sup>, Shumaila Zeb<sup>2</sup>

<sup>1,2</sup>Department of Management Science, SZABIST, Islamabad, Pakistan

<sup>1</sup>Seharsaleem1991@gmail.com, <sup>2</sup>shumaila.zeb@gmail.com

## Keywords

Financial technology, financial inclusion, financial performance, fintech firms

## Summary

Fintech has become an essential part of society as a result of the fourth industrial revolution [1,2]. It has changed every aspect of providing financial services, thus raising financial inclusion [3] and increasing financial performance [4]. Financial inclusion contributes to growth, as well as poverty and inequality alleviation [5,6]. However, the Pakistani Central Bank's (SBP) survey found only 16% of the population financially included. Thus, the financial industry must implement measures to increase financial inclusion for Pakistan's underprivileged. Exclusion of basic financial services reduces social welfare and protection, causing economic stress and lowering the nation's prosperity [7]. However, due to fintech development, traditional financial institutions' responses to fintech adaptability, innovation, and new entrants also affect its profitability and need to be explored. Fintech data is scarce, especially in developing countries like Pakistan, making research on its effects a new topic to look into.

The study brings into focus new insights from the perspective of fintech based financial inclusion and financial performance. The main goal of the study is to find out how commercial banks' fintech adaptability, innovation intensity, and traditional branch-opening structure affect

the financial inclusion gap and how they affect bank performance. The study will also look at how the growth of fintech firms affects the financial inclusion gap and whether they are a friend or foe.

The study used quantitative positivist methods [8]. This study examined 2006–2021 data. Since Pakistan's FinTech development is exceptional among emerging nations, secondary data from Pakistani commercial banks was used to assess the banks' financial inclusion (FI) and performance (FP). Fixed effect model and Generalized Methods of Moments (GMM) model of dynamic panels were used as estimators to handle various diagnostic test results and to add robustness [9].

Excessive level of a bank's fintech adaptability negatively impacts FI and FP due to banking regulation and risk. Innovation intensity correlated negatively with FI and FP, suggesting that it was seen as a strategic need rather than an advantage. Bank branches ascertained a negative relationship with FP as it has a high cost and requires time for growth, while being positive with FI, whereas fintech firms negatively affect both FI and FP of banks, confirming their inefficient use of technology and service provision.

Scholars, professionals, and policymakers will be interested in the study's findings as the fintech industry grows and integrates with the traditional economy and incumbent financial institutions. According to the study, commercial

banks should collaborate with fintech firms and choose cost-effective technology to improve financial outcomes and inclusivity. Banks no longer require branches because they understand the impact of the digital revolution on consumers [10].

## Acknowledgement

I would like to thank everyone who helped me out during this time. I am indebted to express my deep gratitude to my parents and siblings.

## References

- [1] Iman, N. (2018). Is mobile payment still relevant in the fintech era?. *Electronic Commerce Research and Applications*, 30, 72-82.
- [2] Lin, W. R., Lin, C. Y., & Ding, Y. H. (2020). Factors affecting the behavioral intention to adopt mobile payment: An empirical study in Taiwan. *Mathematics*, 8(10), 1851.
- [3] Kanga, D., Oughton, C., Harris, L., & Murinde, V. (2022). The diffusion of fintech, financial inclusion and income per capita. *The European Journal of Finance*, 28(1), 108-136..
- [4] Putri, W. H., Nurwiyanta, N., Sungkono, S., & Wahyuningsih, T. (2019). The emerging fintech and financial slack on corporate financial performance. *Investment Management & Financial Innovations*, 16(2), 348
- [5] Ahmad, M., Majeed, A., Khan, M. A., Sohaib, M., & Shehzad, K. (2021). Digital financial inclusion and economic growth: Provincial data analysis of China. *China Economic Journal*, 14(3), 291-310.
- [6] Emara, N., & El Said, A. (2021). Financial inclusion and economic growth: The role of governance in selected MENA countries. *International Review of Economics & Finance*, 75, 34-54.
- [7] Naumenkova, S., Mishchenko, S., & Dorofeiev, D. (2019). Digital financial inclusion: Evidence from Ukraine. *Investment Management and Financial Innovations*, 16(3), 194–205.
- [8] Isukul, A., & Tantua, B. (2021). Financial inclusion in developing countries: applying financial technology as a Panacea. *Economic Growth and Financial Development: Effects of Capital Flight in Emerging Economies*, 1-21.
- [9] Almulla, D., & Aljughaiman, A. A. (2021). Does financial technology matter? Evidence from an alternative banking system. *Cogent Economics & Finance*, 9(1), 1934978.
- [10] Hoang, Y. H., Nguyen, D. T., Tran, L. H., Nguyen, N. T., & Vu, N. B. (2021). Customers' adoption of financial services offered by banks and fintechs partnerships: evidence of a transitional economy. *Data Science in Finance and Economics*, 1(1), 77-95.

# Teens' Communication via Social Media: Risks vs Opportunities

Tatiana Poskakalova<sup>1</sup>, Margarita Khusnutdinova<sup>2</sup>, Olga Salomatova<sup>3</sup>

<sup>1,2,3</sup>Center for Interdisciplinary Research on Contemporary Childhood, Moscow, Russia

<sup>1</sup>poskakalova@gmail.com, <sup>2</sup>husnutdinovamr@mgppu.ru, <sup>3</sup>k-ta@list.ru

## Keywords

Adolescents, digital socialization, communication, social media, risks

## Summary

The majority of research works on adolescents' online activities and communication focus on the negative effects of digital media use [1,2]. However, today the virtual world cannot be seen only from the perspective of threat. Today the borders between the real and virtual worlds are extremely flexible, creating specific conditions for young people to develop and transit into adulthood [3,4].

The results of an empirical study "Digital Socialization of Adolescents", conducted on the basis of the Center for Interdisciplinary Research on Contemporary Childhood, MSUPE, proved that social networks might provide new communicative opportunities and become a resource for obtaining social support and self-knowledge through the creation of desired images and experimenting with self-presentation.

The data in the framework of the project was collected from May to June, 2022, via Google Forms and represented a survey on the basis of the a questionnaire with 73 questions, related to the motives, preferences and adolescents' online behavioral patterns. The sample included 539 Russian adolescents, aged from 12 to 18 years old.

The empirical data showed that even though most adolescents appreciate the virtual possibilities of online communication, they still prefer real life contacts such as going out or gathering together offline. Moreover,

adolescents prefer to make friends offline rather than online, considering social media exclusively as an additional channel to live communication.

On the other hand, adolescents value social media for the opportunity to "be themselves and say what they think". Interestingly, the majority of respondents rely on their own opinions or parental advice while making important decisions, rather than on the opinions of their friends, other adults (teachers, relatives, etc.) or acquaintances from the Internet.

All in all, the study, in the line with other Center's projects on digital media use in adolescence, demonstrates that the majority of young people have already become attuned to the virtual reality and have worked out safety rules and priorities in living their lives in mixed reality [5,6].

## References

- [1] Abrosimova, E.E., Filipova A.G., & Ardalyanova, A.Y. (2019). *Video blogging through the eyes of children and adults: a sociological analysis*. St. Petersburg: Asterion.
- [2] Bogacheva, N.V., et al (Ed). (2019). Myths about "generation Z". *Modern analytics of Education*, 1(22).
- [3] Koroleva, D.O. (2017) "Portrait" of a contemporary teenager through his self-presentation on a social network. Available at: <https://publications.hse.ru/mirror/pubs/share/direct/214135303>
- [4] Soldatova, G.U. (2018). Digital socialization in the cultural-historical paradigm: a changing child in a changing world. *Social Psychology and Society*, 9(3), 71–80.
- [5] Poskakalova, T.A. (2021). The Impact of Aggressiveness on Self-Presentation, Communication and Behavioral Risks of Adolescents in Social Media. *Digital Humanities and Technology in Education (DHTE 2021): Collection of Articles of the II All-Russian Scientific and Practical Conference with*



*International Participation. November 11-12, 2021.*  
Moscow: Publishing house MSUPE, 432–445.

- [6] Rubtsova, O.V., Poskalkalova, T.A., & Shiryayeva, E.I.  
(2021). Features of On-Line Behavior in Adolescents

with Different Levels of Self-Concept Clarity.  
*Psychological Science and Education*, 26(4), 20–33

# Education in Antimicrobial Stewardship: Awareness of Antibiotics in Drinking Water

Nikola Puvača<sup>1</sup>, Svetlana Ignjatijević<sup>2</sup>, Jelena Vapa Tankosić<sup>3</sup>, Radivoj Prodanović<sup>4</sup>

<sup>1,2,3,4</sup>Faculty of Economics and Engineering Management in Novi Sad, University Business Academy in Novi Sad, Novi Sad, Serbia

<sup>1</sup>nikola.puvaca@fimek.edu.rs, <sup>2</sup>ceca@fimek.edu.rs, <sup>3</sup>jvapa@fimek.edu.rs, <sup>4</sup>rprodanovic@fimek.edu.rs

## Keywords

Education, antimicrobial resistance, sanitation, water, public health

## Summary

Overuse of antimicrobials in agriculture, veterinary medicine, and medicine has resulted in an epidemic of antimicrobial resistance (AMR) [1]. Several factors are responsible for the spread of antibiotic-resistant bacteria, such as the use of antimicrobial drugs in health care, agriculture and livestock, and the environment [2]. Resistance genes and resistant microorganisms enter the soil, air, drinking water, and sediment through various routes and hotspots, such as hospital wastewater, agricultural waste, and wastewater treatment plants indicating the need for antimicrobial stewardship programs (AS) to be expanded in all related systems [3,4]. Education is a key component of antimicrobial stewardship interventions; however, current guidelines suggest that education should not be used alone, but rather should support other stewardship activities [5]. Typically, such interventions target prescribers, often general practitioners or veterinarians, with few studies targeting pharmacists, nurses, or even stewardship staff. There are many educational interventions available regarding antimicrobial stewardship, but they are not exclusive [6]. A concomitant

stewardship intervention, such as a prospective audit and feedback, is also provided. Prescription behavior may be positively impacted by such strategies, but education cannot be isolated from other interventions. A variety of educational methods have been used to teach students, including one-time seminars and online e-learning modules [7]. However, social media platforms and problem-based learning modules have also been employed in supporting education in AS [8]. While there is little evidence supporting the use of educational interventions as stand-alone interventions outside of regional public health interventions, they appear to be an integral component of AS. To demonstrate a broader role for education in AS activities, future studies should investigate the efficacy of educational interventions, such as those targeting non-prescribers, diseases, and general public education to raise their awareness of antibiotic residues in the environment [9]. If global mitigation strategies are to be effective, it is important to identify high-risk environments that cause resistance to evolve and spread. AMR transmission is therefore impacted by factors such as infection control, sanitation, access to clean water, antimicrobials, diagnostics, travel, and migration [2]. In this review, a variety of mechanisms are discussed, including AMR as a global problem and factors that may contribute to its spread, as well as antibiotics in drinking water, AS education, and awareness.

## Acknowledgement

This paper is a part of the project financed by the City Administration for Environmental Protection of Novi Sad of the Republic of Serbia under Grant 501-1/2022-35 v-II “Identification of antibiotics in drinking water to raise awareness of the danger to public health and the environment”.

## References

- [1] Puvača, N., & de Llanos Frutos, R. (2021). Antimicrobial Resistance in Escherichia Coli Strains Isolated from Humans and Pet Animals. *Antibiotics*, *10*, 69.
- [2] Puvača, N., Vapa Tankosić, J., Ignjatijević, S., Carić, M., & Prodanović, R. (2022). Antimicrobial Resistance in the Environment: Review of the Selected Resistance Drivers and Public Health Concerns. *Journal of Agronomy, Technology, and Engineering Management*, *5*, 793–802.
- [3] Lehner, C., et al. (2020). Effect of Antimicrobial Stewardship on Antimicrobial Prescriptions for Selected Diseases of Dogs in Switzerland. *Journal of Veterinary Internal Medicine*, *34*, 2418–2431.
- [4] Majumder, M. A. A., et al. (2020). Antimicrobial Stewardship: Fighting Antimicrobial Resistance and Protecting Global Public Health. *Infection and Drug Resistance*, *13*, 4713–4738.
- [5] Satterfield, J., Miesner, A. R., & Percival, K.M. (2020). The Role of Education in Antimicrobial Stewardship. *Journal of Hospital Infection*, *105*, 130–141.
- [6] King, S., et al. (2016). Antimicrobial Stewardship. *Rand Health Quarterly*, *5*, 2.
- [7] Saiyad, S., Virk, A., Mahajan, R., & Singh, T. (2020). Online Teaching in Medical Training: Establishing Good Online Teaching Practices from Cumulative Experience. *International Journal of Applied and Basic Medical Research*, *10*, 149–155.
- [8] Courtenay, M., et al. (2022). Delivery of Antimicrobial Stewardship Competencies in UK Pre-Registration Nurse Education Programmes: A National Cross-Sectional Survey. *Journal of Hospital Infection*, *121*, 39–48.
- [9] Rahman, M. M., et al. (2022). An Overview of Antimicrobial Stewardship Optimization: The Use of Antibiotics in Humans and Animals to Prevent Resistance. *Antibiotics*, *11*, 667..







[www.paksom.cosrec.org](http://www.paksom.cosrec.org)

ISBN: 978-86-82602-00-2

